

Electric Double Wall Oven

E30EW85GSS designer series



Wave-Touch™ Control Panel Technology

A simple touch, anywhere on the panel, lights oven controls and provides access to all oven functions. This allows easy programming while keeping activated functions lighted for easy monitoring.



Smooth-Glide™ Oven Racks

Fully extending oven racks with a centered easy-grip handle make access to oven contents safe and easy. Patented ball bearing rack system allows racks to glide effortlessly.



Multi-Option Cooking with Temperature Probe

Seven cooking modes with eight functions for essential versatility. The temperature probe monitors the cooking progress and automatically indicates when the meat is precisely cooked.



CustomConvec 3™ Convection System

A third cooking element using a variable-speed technology fan, when combined with temperature-setting options, provides premium performance with more cooking choices.

30" ELECTRIC DOUBLE WALL OVEN

Sabbath Mode (Star-K® Certified)	Yes
----------------------------------	-----

OVEN FEATURES

Upper Oven Cavity (Cu. Ft.)	4.2
Lower Oven Cavity (Cu. Ft.)	4.2
Cobalt Blue Interior	Yes
CustomConvec 3™ Convection System	Yes
Hidden Bake Element	Yes
Convection Conversion	Yes
Preheat Control	Yes
Keep Warm	Yes
Light Clean/Heavy Clean	Yes
Self-Cleaning with Auto-Safety Latch™	Yes
Self-Cleaning Cycle	Yes
Self-Cleaning Rack Removal Alert	Yes
Dual Radiant™ Baking System	Yes
Eight-Pass Broil & Radiant Bake Element	Yes
Smooth-Glide™ Racks	6
Standard Racks	2
Halogen Lighting	Yes
Porcelain Broiler Pan with Grill	Yes

CONTROL PANEL FEATURES

Electronic Oven Control	Yes
Electronic Clock/Timer	Yes
Electronic Temperature Display	Yes
Glass Wave-Touch™ Control with Blue LED Display	Yes
Toggle Control	Yes
Automatic Oven – Delay, Cook & Off	Yes
Electronic Lockout	Yes
Automatic Oven Shutoff – 12 Hour	Yes
Auto Set™ Control – Convection	Yes
Programmable for °F or °C	Yes
Integrated Halogen Oven Light – Touch Pad	Yes

DOOR STYLE

Cool-Touch™ Door	Yes
Removable Door	Yes
Oven Door Window	Large
Stainless Door Handle/Towel Bar	Yes

SPECIFICATIONS

Oven Cavity Dimensions –	
Height	16-1/2"
Width	24-1/8"
Depth	18-1/32"
Overall Exterior Dimensions –	
Height	52-9/16"
Width	30"
Depth (Including Door) (with 90° Door Open)	24-5/8" 47-7/8"
Power Supply Location	Left Bottom Rear
Amps @ 240/208 Volts	33.3/28.9
Connected Load (kW Rating) @ 240/208 Volts	8.0/6.0
Bake Element (Watts @ 240/208 Volts)	2200
Broil Element (Watts @ 240/208 Volts)	4000
Armored Electrical Cable	Included
Product Weight	328 Lbs.
Shipping Weight (Approx.)	353 Lbs.
UPC (0-57112-)	09634-6

NOTE: Always consult local and/or national electric codes. Refer to Product Installation Guide for detailed installation instructions on the web at electroluxusa.com.

Specifications subject to change.

Electric Double Wall Oven

E30EW85GSS designer series

Electrolux | ICON™

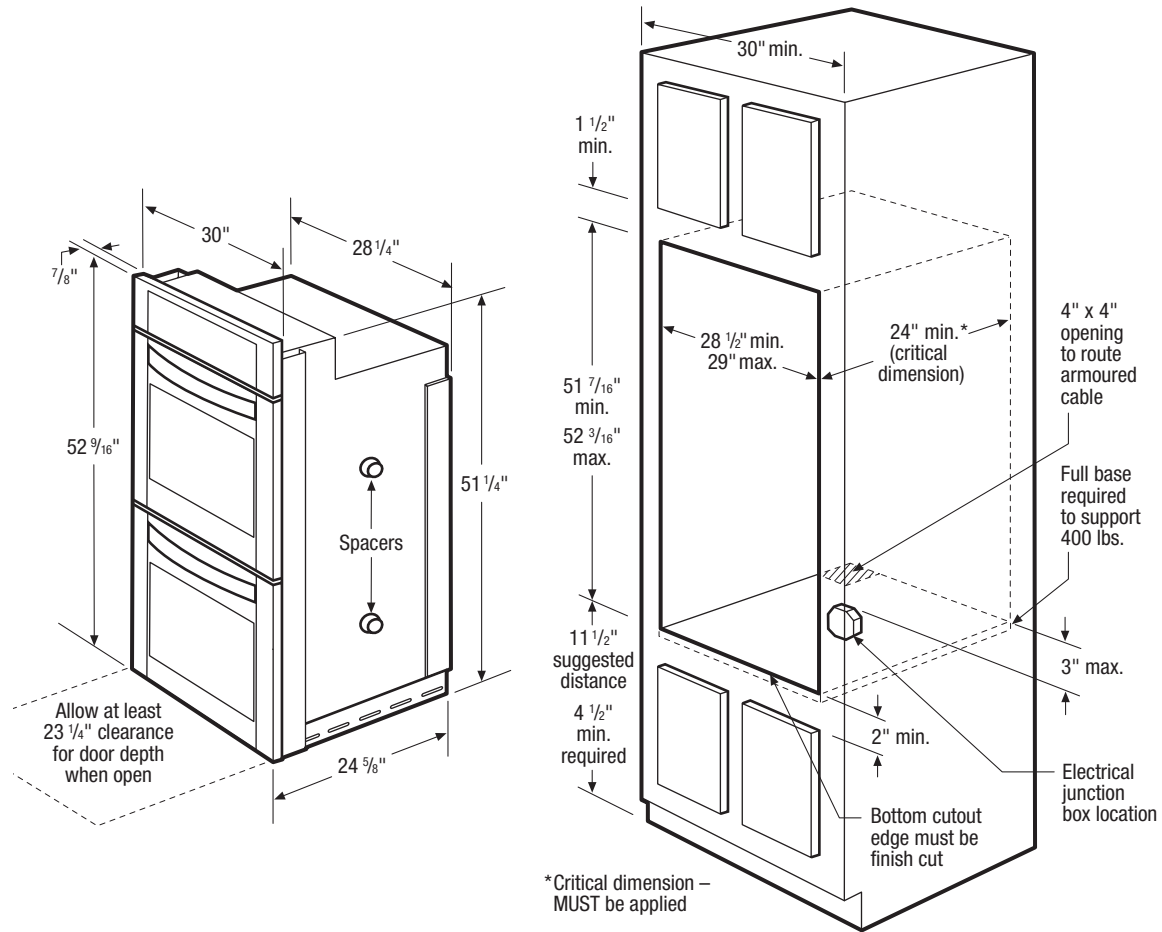

30" Electric Double Wall Oven Specifications

- Product Weight – 328 Lbs.
- Single phase 3- or 4-wire cable, 120/240 or 120/208 Volt, 60 Hertz AC only electrical supply with ground required on separate circuit fused on both sides of line.
- Connected Load (kW Rating) @ 240/208 Volts = 8.0/6.0kW
- Amps @ 240/208 Volts = 33.3/28.9 Amps
- Always consult local and/or national electric codes.
- Minimum 23-1/4" clearance for oven door depth when open.
- Suggested distance from floor is 11-1/2". Minimum required distance is 4-1/2".

- Minimum 24" deep cutout dimension is critical for proper installation, to ensure that oven's faceplate will fit flush against cabinet front.
- Full oven base of solid plywood or similar material required, capable of supporting 400 Lbs.
- Base must be level and cabinet front must be square with finish-cut bottom edge.
- Double Wall Ovens are NOT approved to be used in stackable or side-by-side installation.

Note: Refer to Product Installation Guide for detailed instructions on the web at electroluxusa.com.

 **The Electrolux Group**

USA • 250 Bobby Jones Expressway • Augusta, GA 30907 • 1-877-4electrolux (1-877-435-3287) • electroluxusa.com
 CANADA • 5855 Terry Fox Way • Mississauga, ON L5V 3E4 • 1-800-265-8352 • electroluxca.com

E30EW85GSS 08/07

© 2007 Electrolux Major Appliances, NA

High standards of quality at Electrolux Major Appliances mean we are constantly working to improve our products. We reserve the right to change specifications or discontinue models without notice.

Printed in the U.S.A.