



**SPLIT TYPE
ROOM AIR CONDITIONER
WALL MOUNTED type**

**SERVICE
MANUAL**

Models

Indoor unit	Outdoor unit
MW30C3F	MR30C3F

CONTENTS

SPECIFICATIONS.....	1
DIMENSIONS	2
REFRIGERANT SYSTEM DIAGRAM....	4
CIRCUIT DIAGRAM	5
INDOOR PCB CIRCUIT DIAGRAM	6
OUTDOOR PCB CIRCUIT DIAGRAM ...	9
ERROR CONTENTS	14
DISASSEMBLY ILLUSTRATION	15
PARTS LIST	23
STANDARD ACCESSORIES.....	25

SPECIFICATIONS

INDOOR UNIT	MW30C3F
OUTDOOR UNIT	MR30C3F
COOLING CAPACITY	30,700 BTU/hr

ELECTRICAL DATA

POWER SOURCE	208 V / 230 V
FREQUENCY	60 Hz
RUNNING CURRENT	15.2 A
INPUT WATTS	3,460 W
SEER	15.0
MOISTURE REMOVAL	9.7 Pts/hr (4.6 L/hr)
AIR CIRCULATION-High	647 cfm (1,100 m ³ /hr)

COMPRESSOR

TYPE	Hermetic motor compressor, 4 poles, Rotary type
DISCRIMINATION	5KD240XAD21
POWER SOURCE	208 V / 230 V 60Hz
REFRIGERANT R-410A	4 lb.10 oz (2,100 g)

FAN MOTOR

POWER SOURCE	208 V / 230 V	
INDOOR UNIT	HIGH	1,330 r.p.m.
	MED	1,120 r.p.m.
	LOW	940 r.p.m.
	QUIET	830 r.p.m.
OUTDOOR UNIT	850 r.p.m.	

DIMENSIONS

INDOOR UNIT H x W x D	12-5/8 x 39-1/4 x 9 inch
	320 x 998 x 228 mm
OUTDOOR UNIT H x W x D	32-3/4 x 35-3/8 x 13 inch
	830 x 900 x 300 mm

WEIGHT

INDOOR UNIT	Gross / Net	40 / 31 lbs. (18 / 14 kg)
OUTDOOR UNIT	Gross / Net	155 / 137 lbs. (70 / 62 kg)

NOISE LEVEL

INDOOR UNIT	HIGH	47 dB
	MED	41 dB
	LOW	36 dB
	QUIET	32 dB
OUTDOOR UNIT		53 dB

REFRIGERANT CHARGE (R410A)

FULL CHARGE	Pipe length 20 m	4 lb. 10 oz. (2,100 g)
	30 m	5 lb. 8 oz. (2,500 g)
	40 m	6 lb. 6 oz. (2,900 g)
	50 m	7 lb. 4 oz. (3,300 g)
ADDITIONAL CHARGE		40 g/m

OUTLINE AND DIMENSIONS

Unit : inch (mm)

INDOOR UNIT

Model : MW30C3F

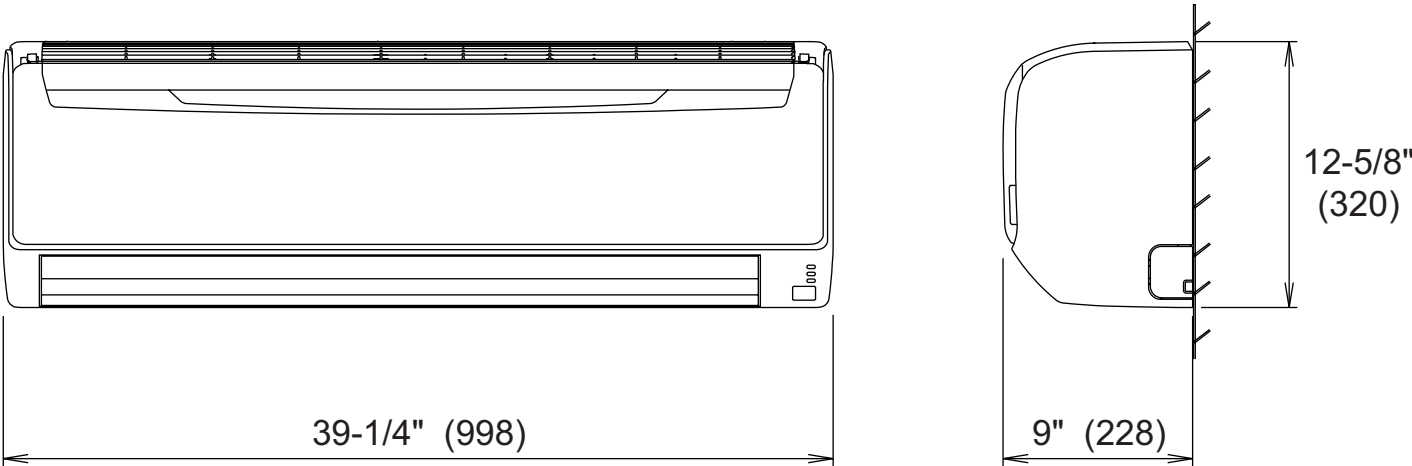

OUTDOOR UNIT

Model : MR30C3F

Unit : inch (mm)

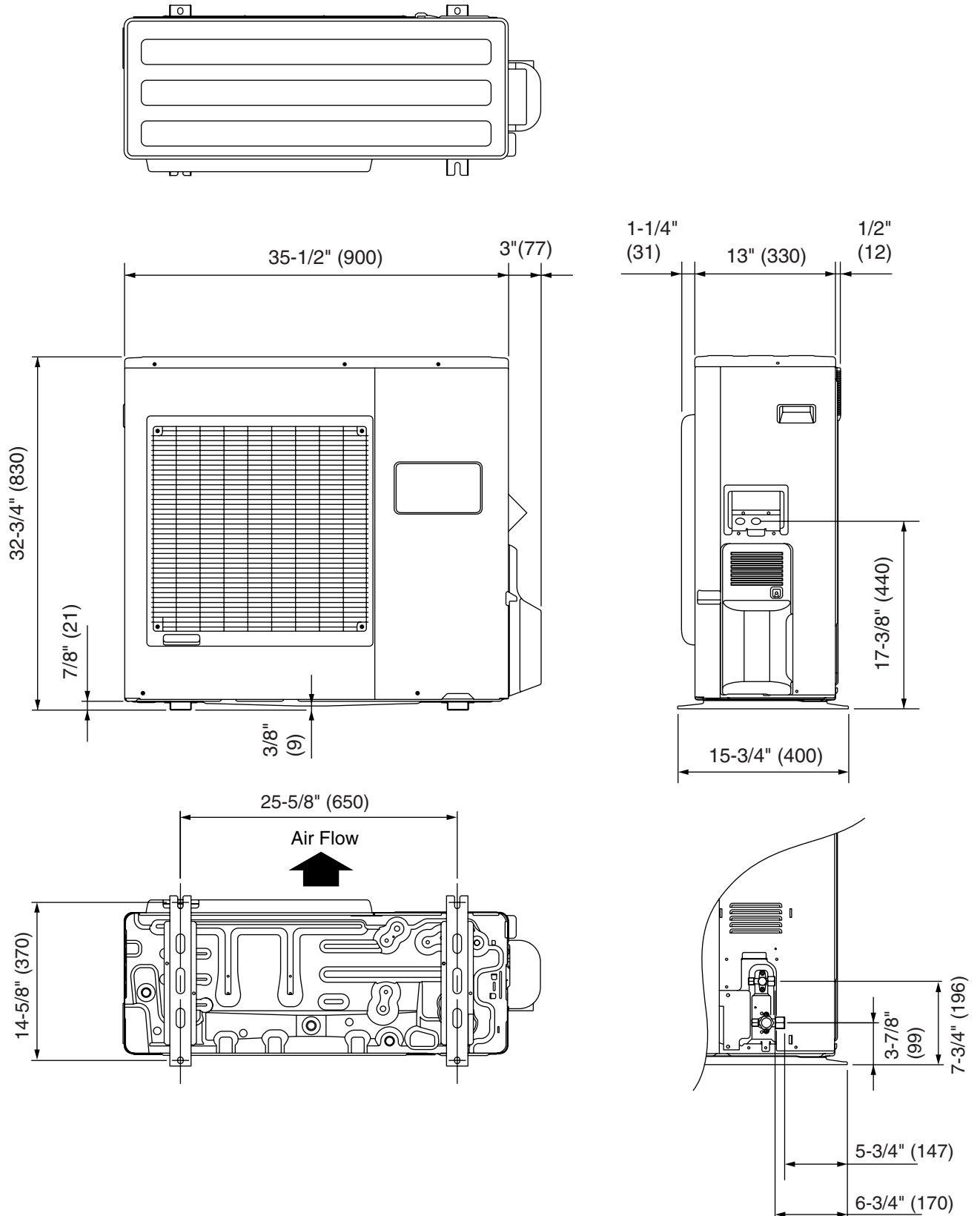

REFRIGERANT SYSTEM DIAGRAM

Models : MW30C3F / MR30C3F

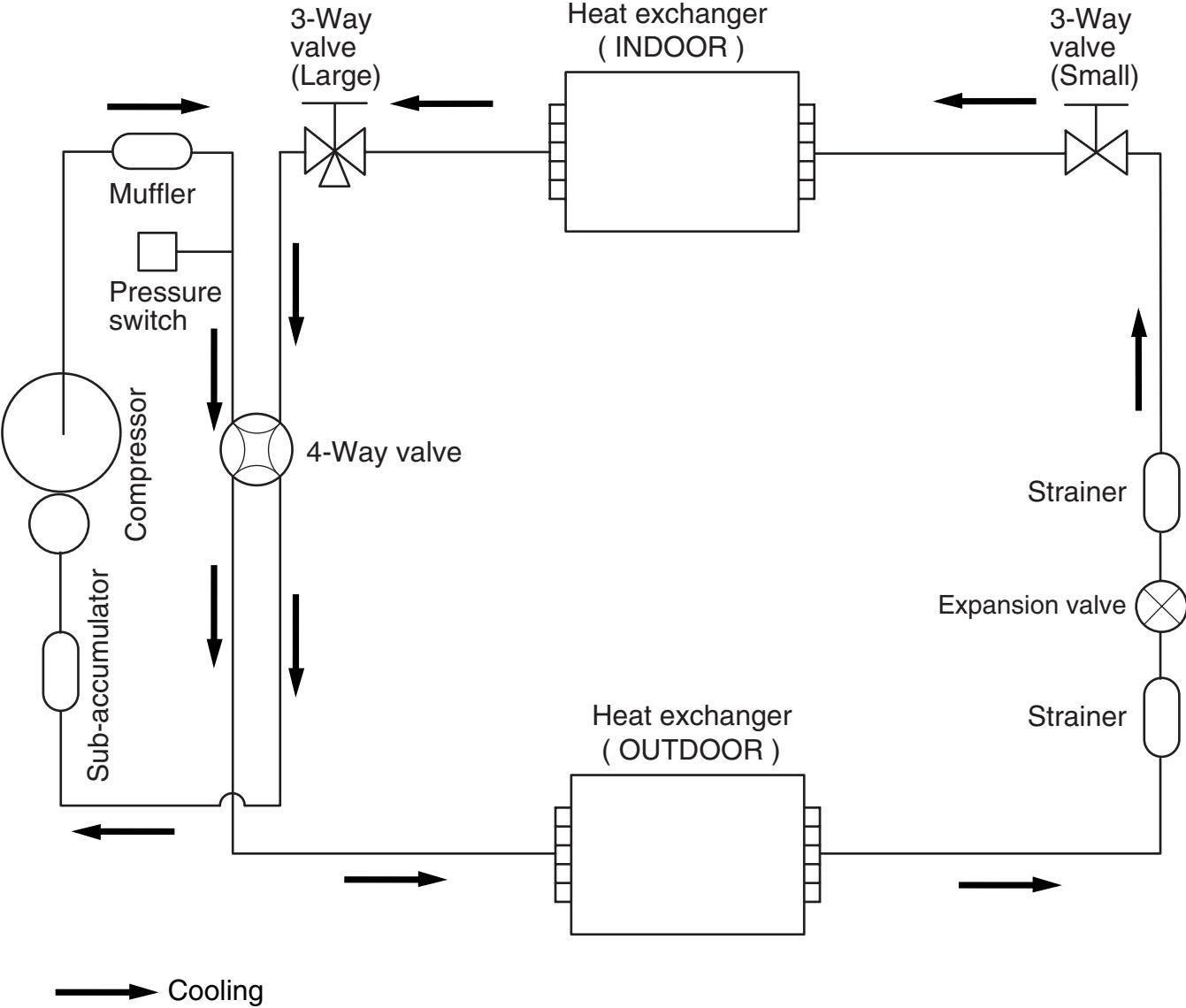

Refrigerant pipe diameter
 Liquid : 3/8" (9.52 mm)
 Gas : 5/8" (15.88 mm)

CIRCUIT DIAGRAM

INDOOR UNIT

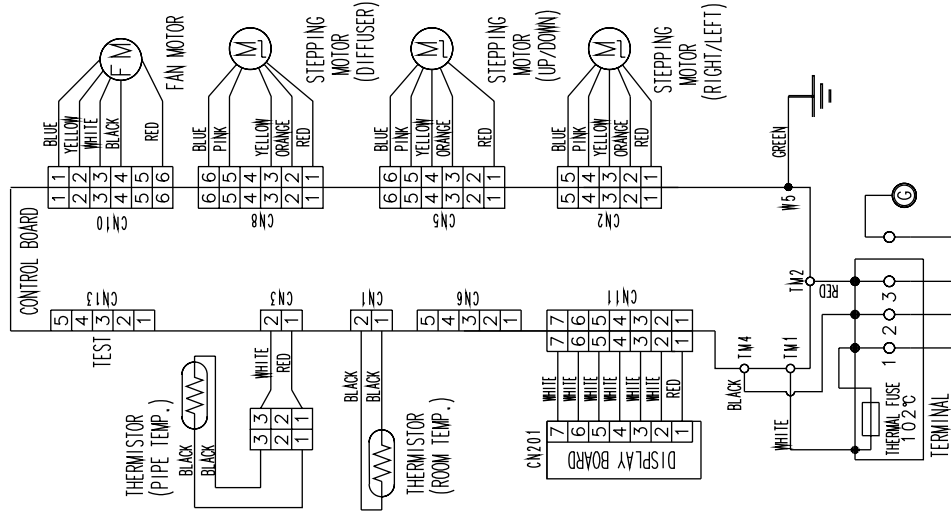

OUTDOOR UNIT

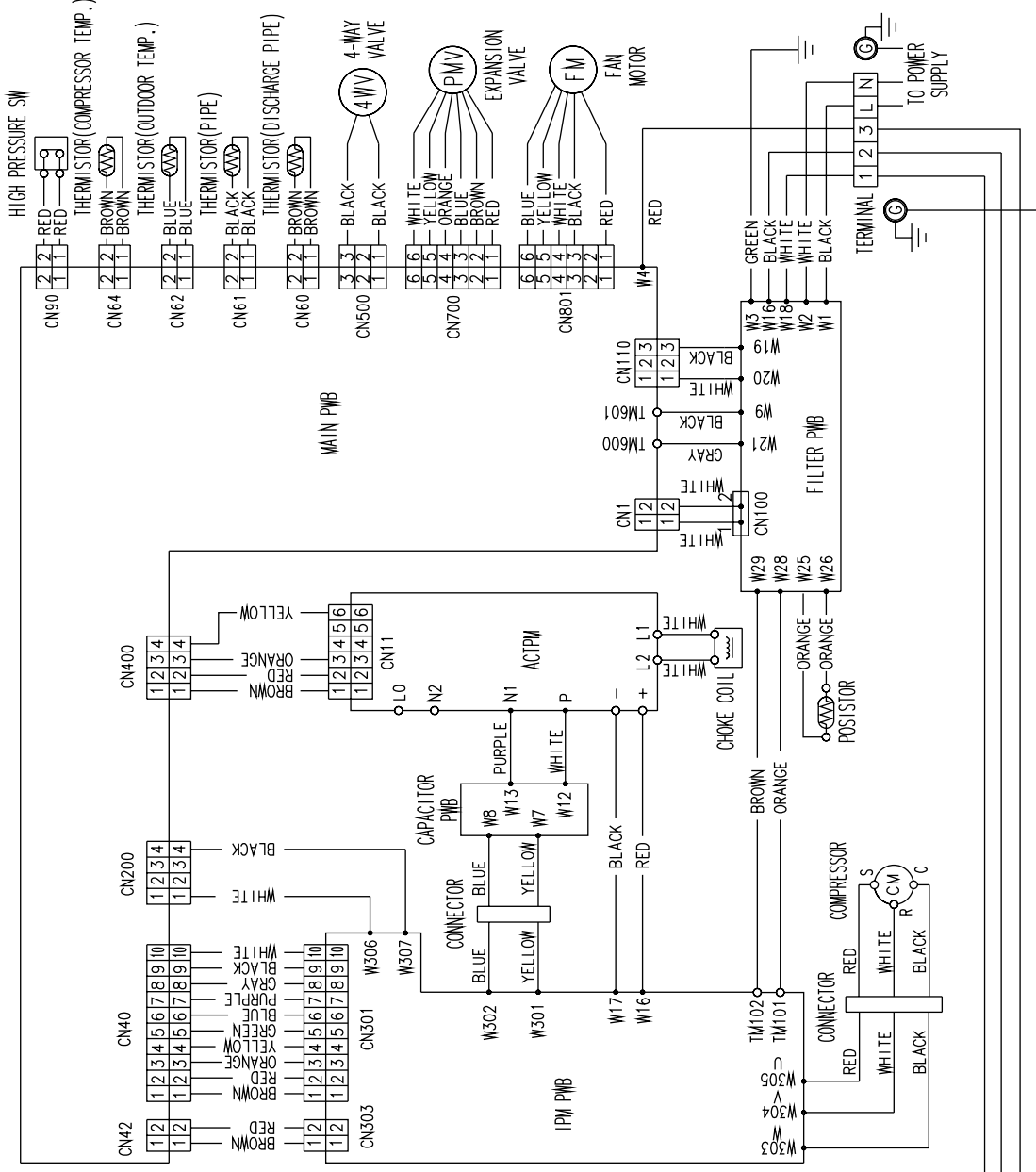

INDOOR PCB CIRCUIT DIAGRAM

Model : MW30C3F

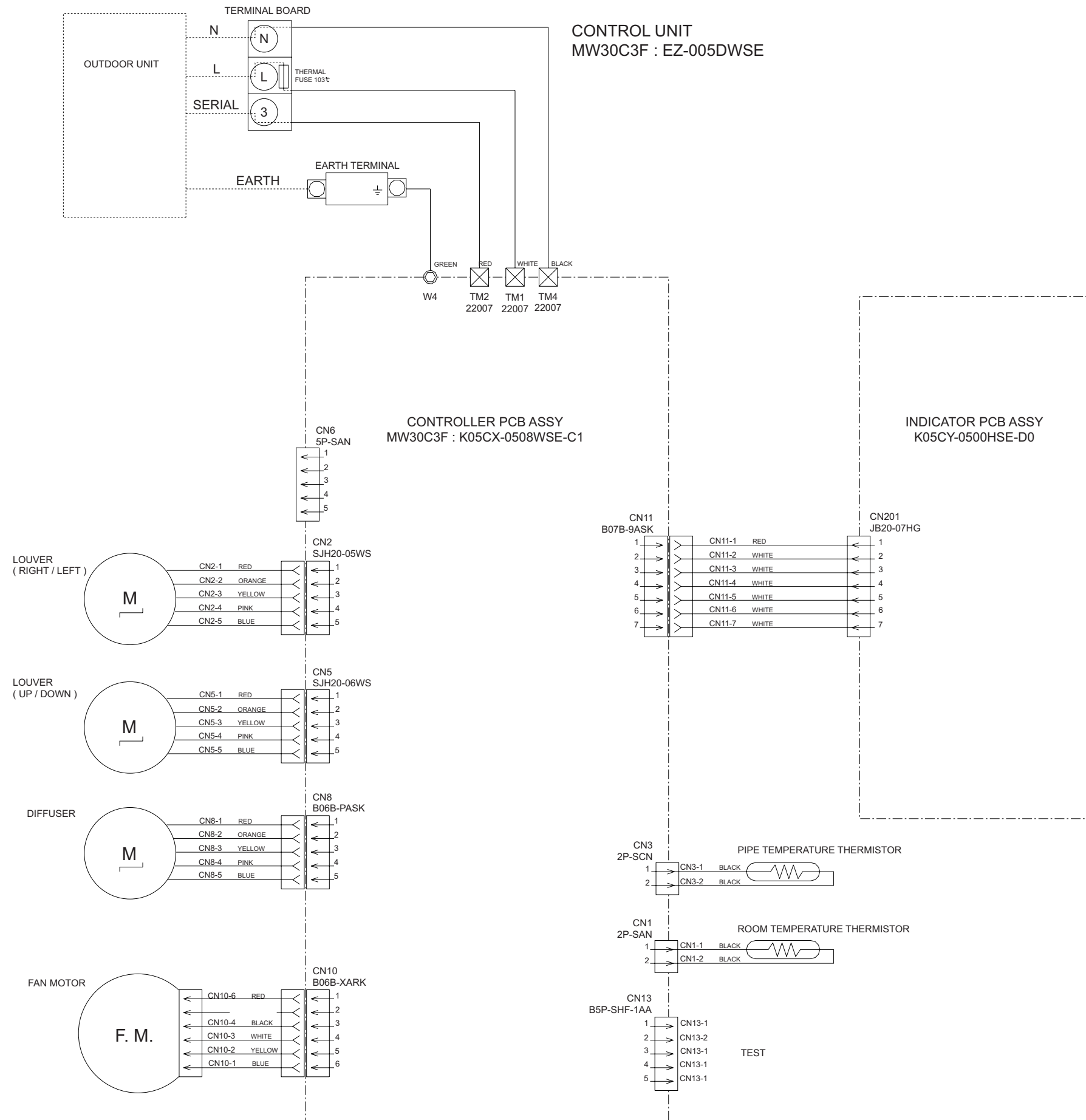

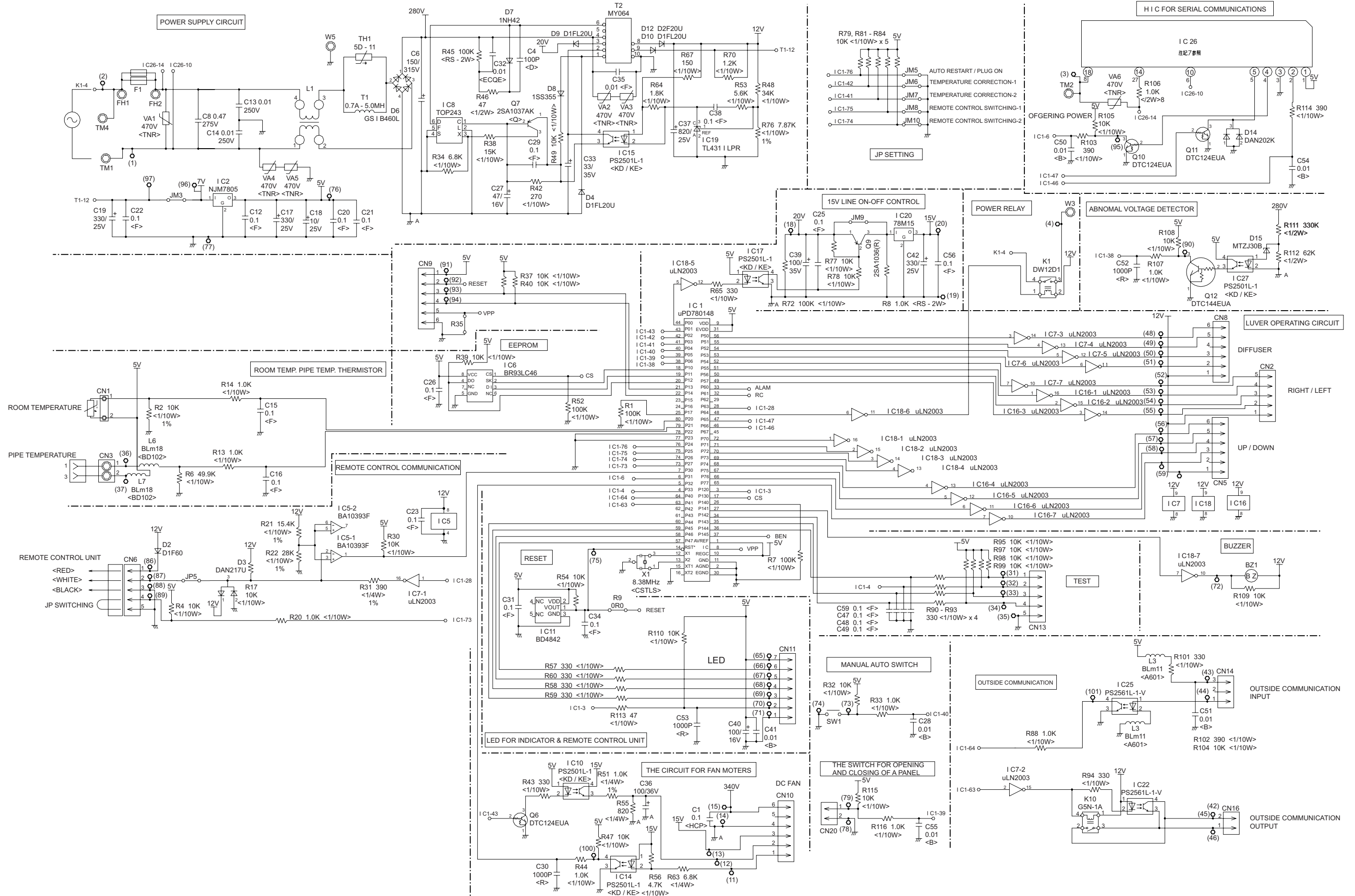

Model : MW30C3F

INDICATOR PCB ASSY K05CY-0500HSE-D0

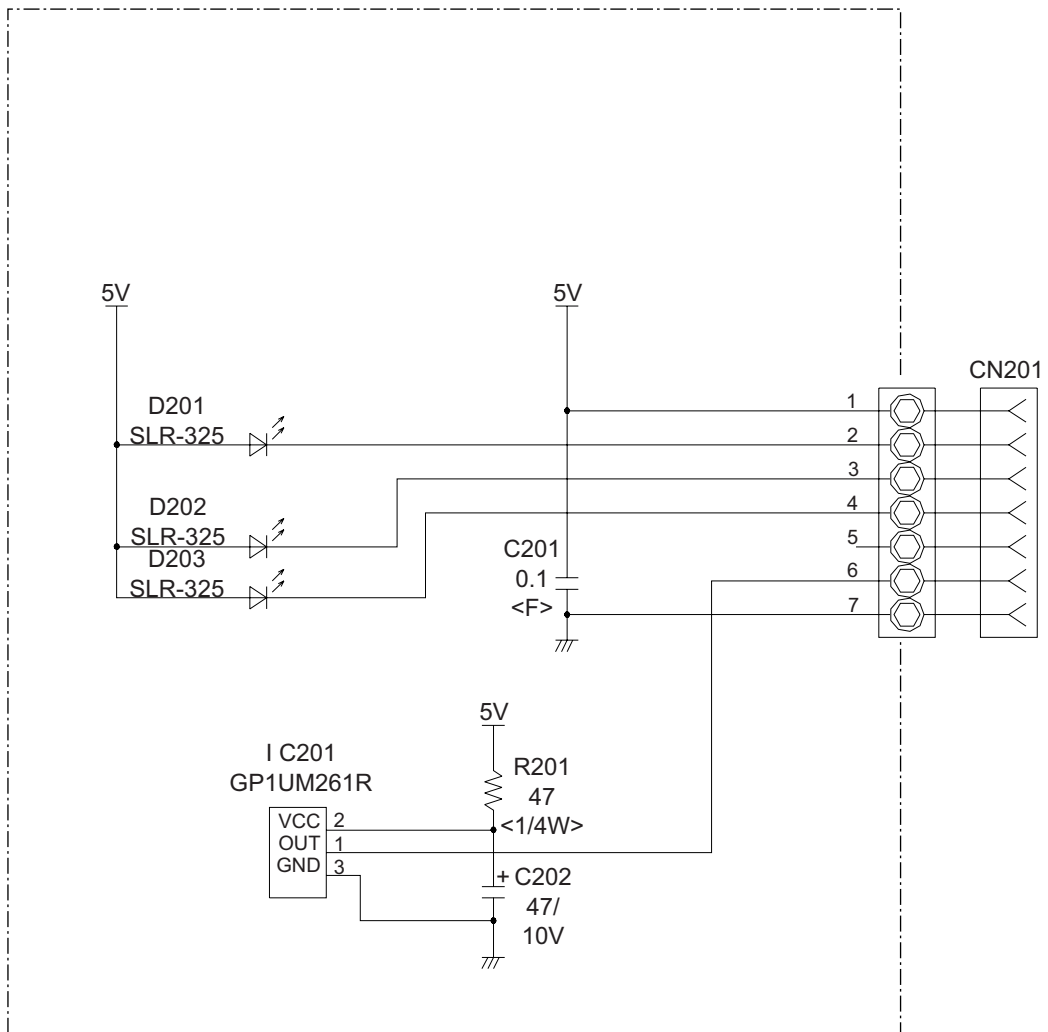

OUTDOOR PCB CIRCUIT DIAGRAM

Model : MR30C3F

INVERTER ASSEMBLY EZ-00502HUE

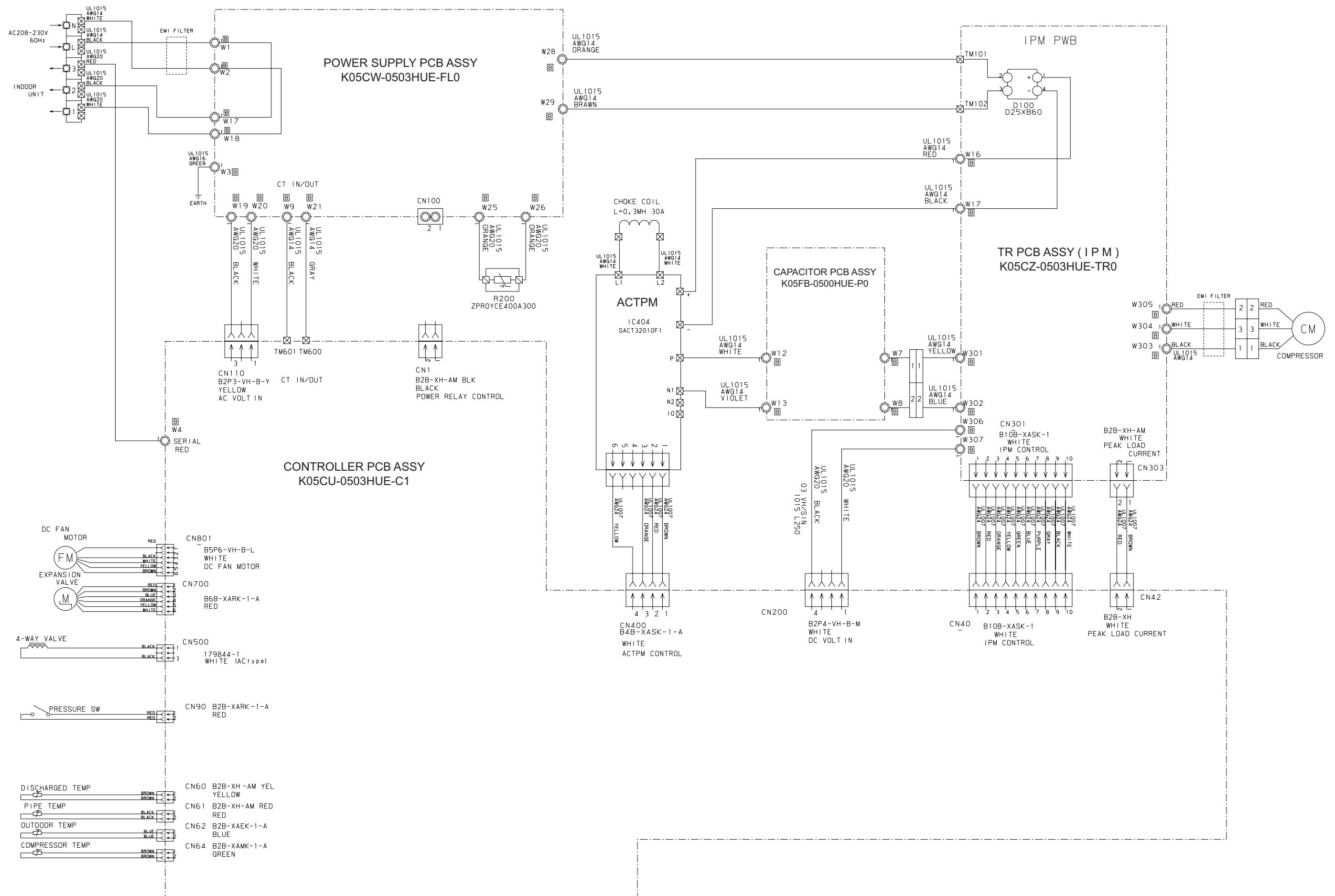

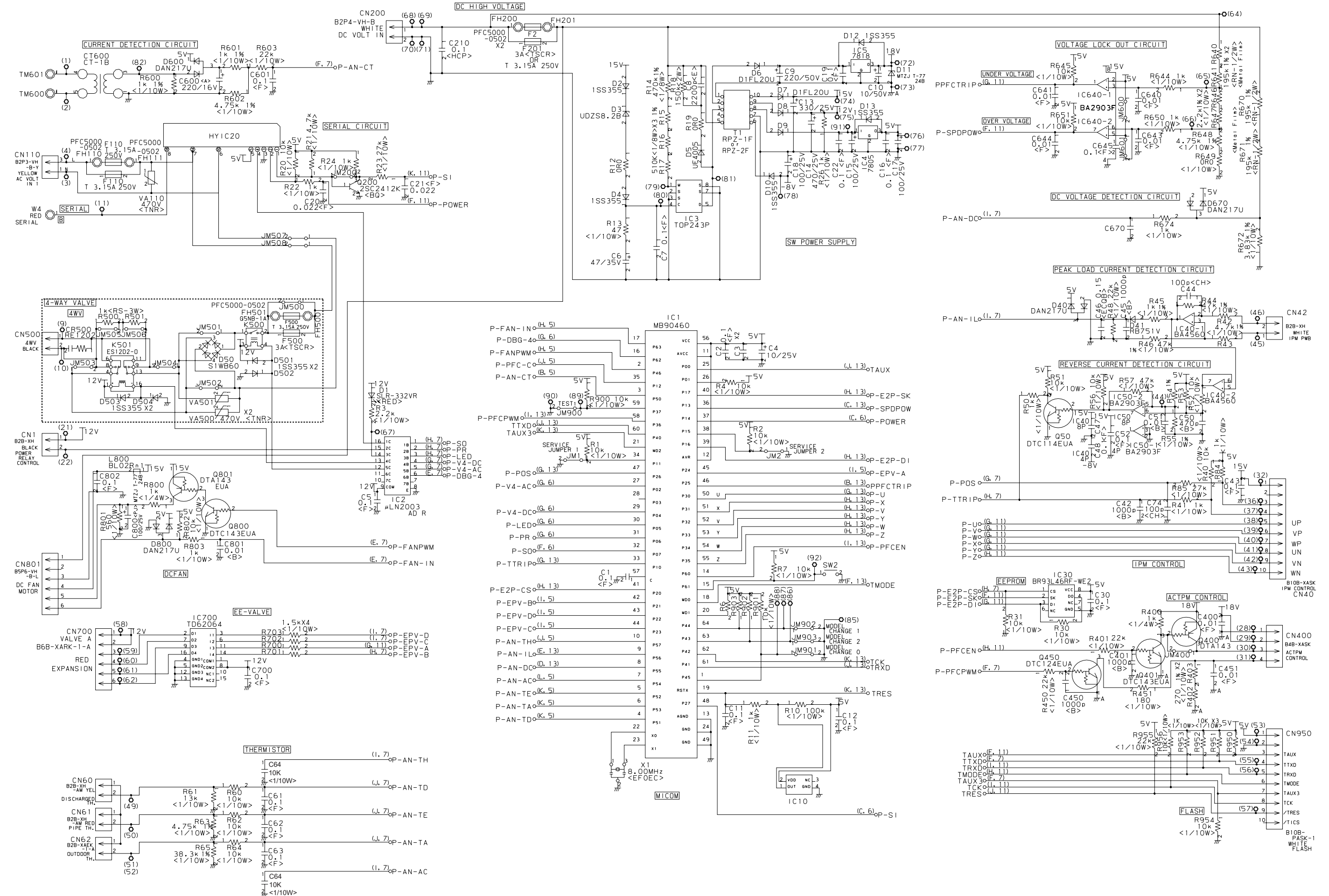

Model : MR30C3F

TR PCB ASSY (I P M) K05CZ-0503HUE-TR0

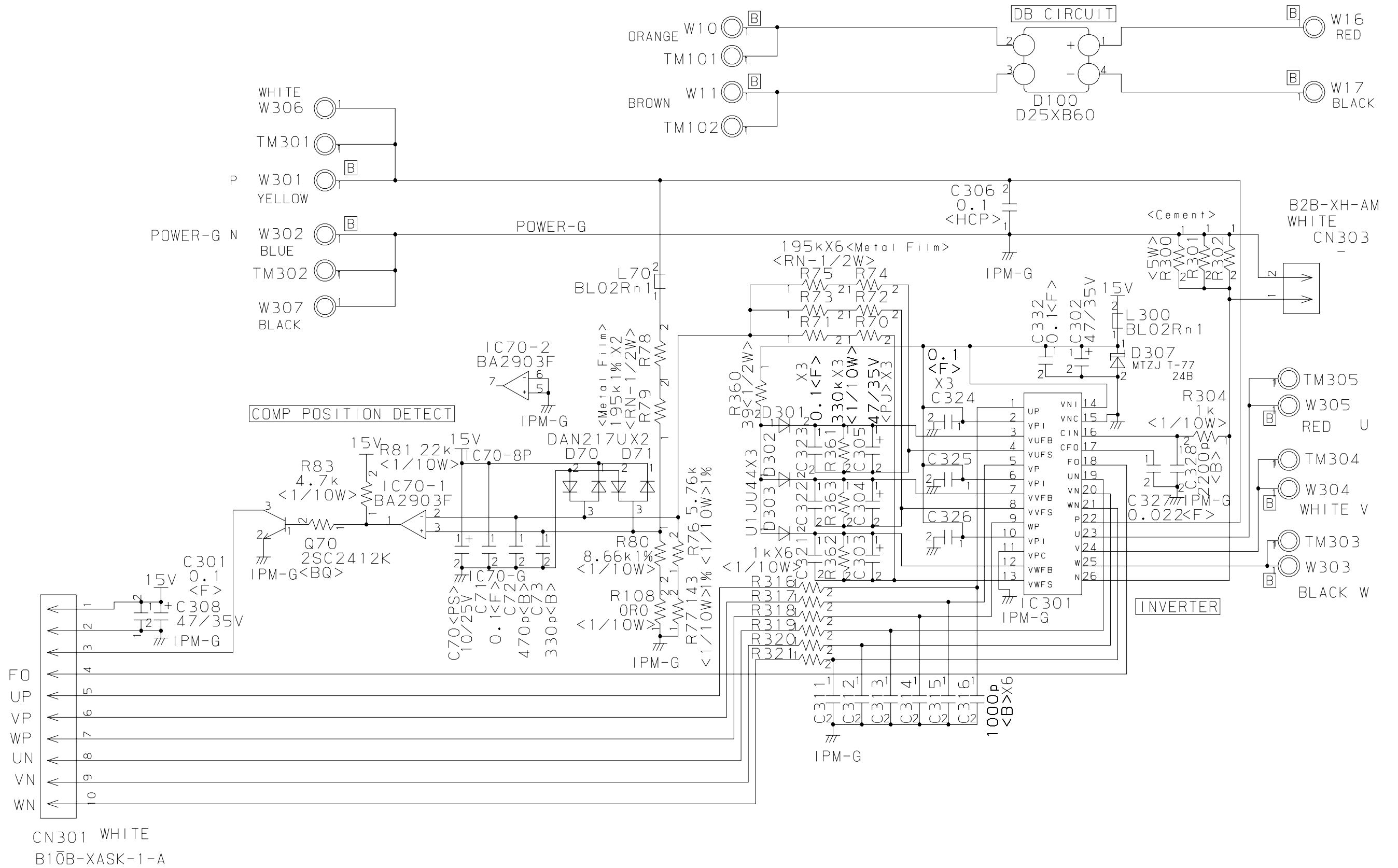

Model : MR30C3F

CAPACITOR PCB ASSEMBLY K05FB-0500HUE-P0

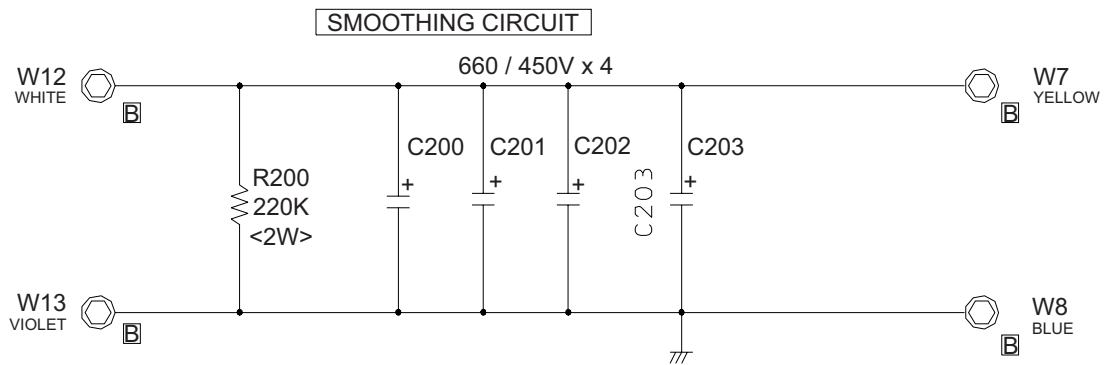

ERROR CONTENTS

Error	Display		Error
	Operation LED	Timer LED	
Serial signal error	Normal	2 flash	Serial signal (reverse) error, at operation start up
		3 flash	Serial signal (reverse) error, during operation
		4 flash	Serial signal (forward) error, at operation start up
		5 flash	Serial signal (forward) error, during operation
		8 flash	Wired remote controller error
Indoor unit thermistor error	2 flash	2 flash	Indoor temperature thermistor open / short
		3 flash	Heat exchanger middle thermistor open / short
Outdoor unit thermistor error	3 flash	2 flash	Discharge thermistor open / short
		3 flash	Heat exchanger thermistor open
		4 flash	Outdoor temperature thermistor open / short
		8 flash	Compressor temperature thermistor open / short
Indoor unit control error	4 flash	2 flash	Forced automatic SW welded
		3 flash	Main relay welded
		4 flash	Power interruption error
		7 flash	VDD permanent stop protection
		8 flash	reverse VDD permanent stop protection
Outdoor unit control error	5 flash	2 flash	Current trip error
		3 flash	CT abnormal
		5 flash	Compressor location detection error
		6 flash	Outdoor unit fan drive system abnormal
Indoor fan motor error	6 flash	2 flash	Abnormal lock
		3 flash	Abnormal rotation
Refrigerant cycle error	7 flash	2 flash	Discharge Temperature abnormal
		3 flash	Cooling high pressure abnormal rise
		5 flash	Pressure switch trouble
Optional function error	8 flash	2 flash	Active filter voltage trouble (second time)
		3 flash	Active filter voltage trouble (first time)
		4 flash	PFC circuit error
Model error	Blinking	Blinking	Model error

DISASSEMBLY ILLUSTRATION

Model : MW30C3F

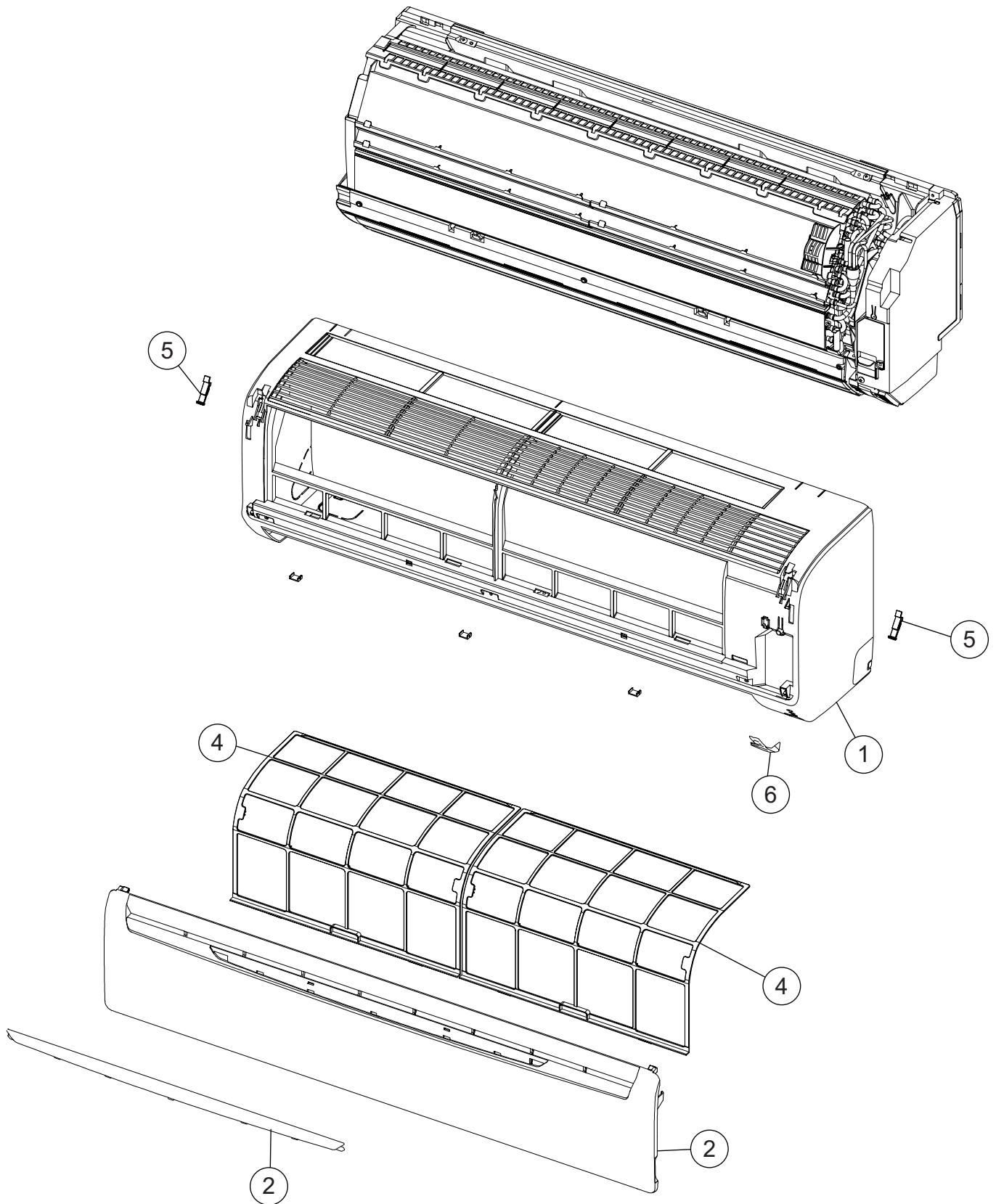

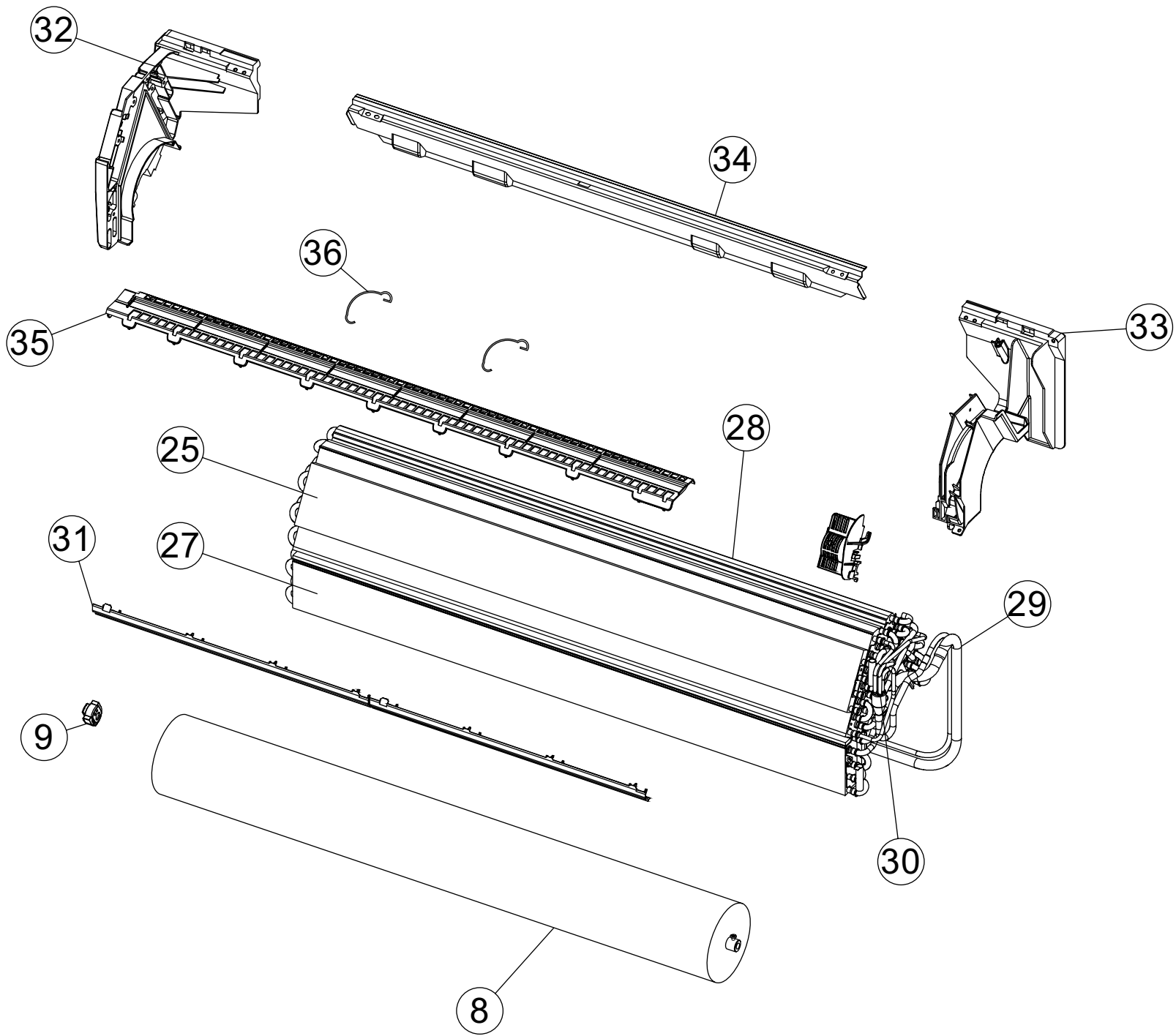

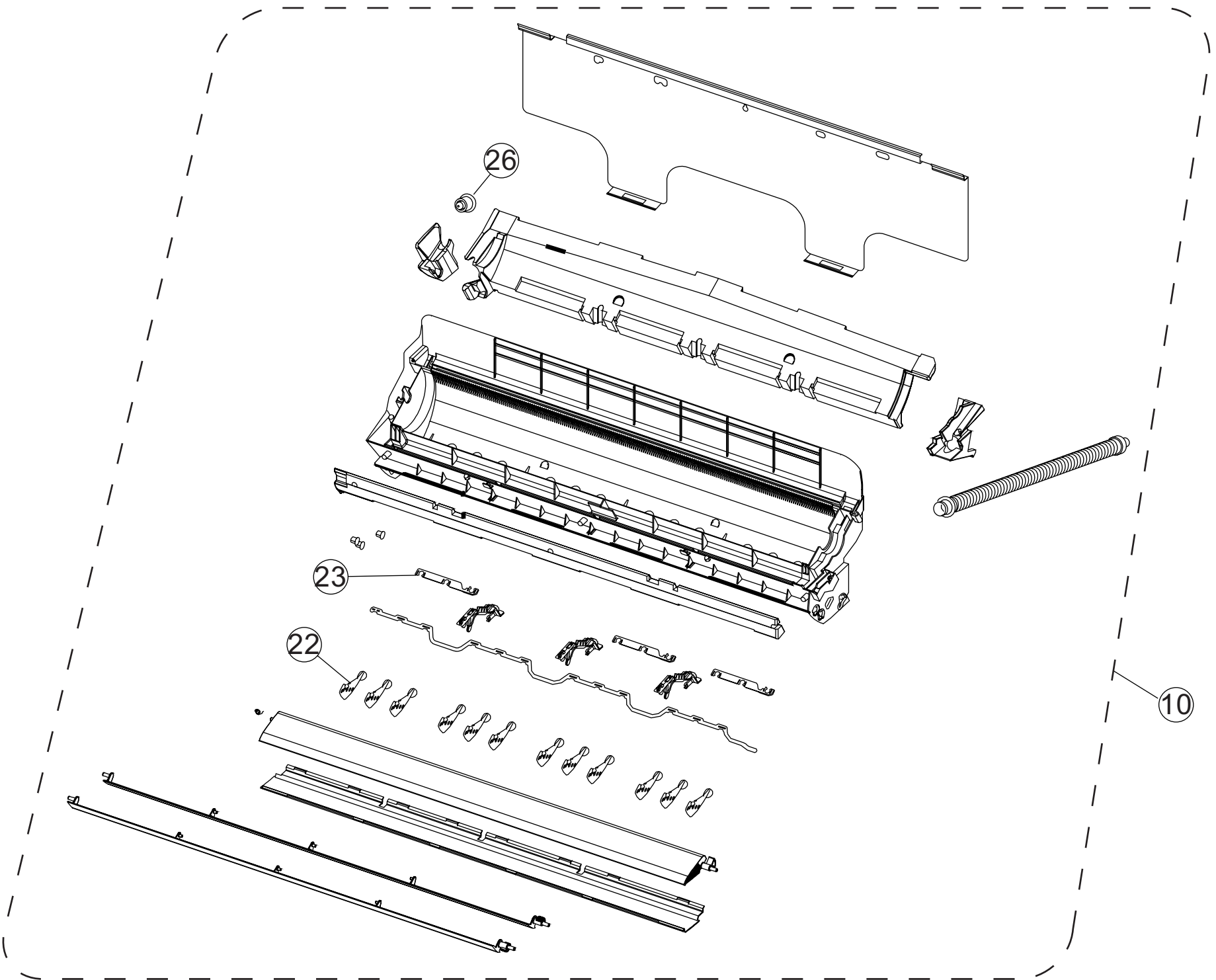

Model : MW30C3F

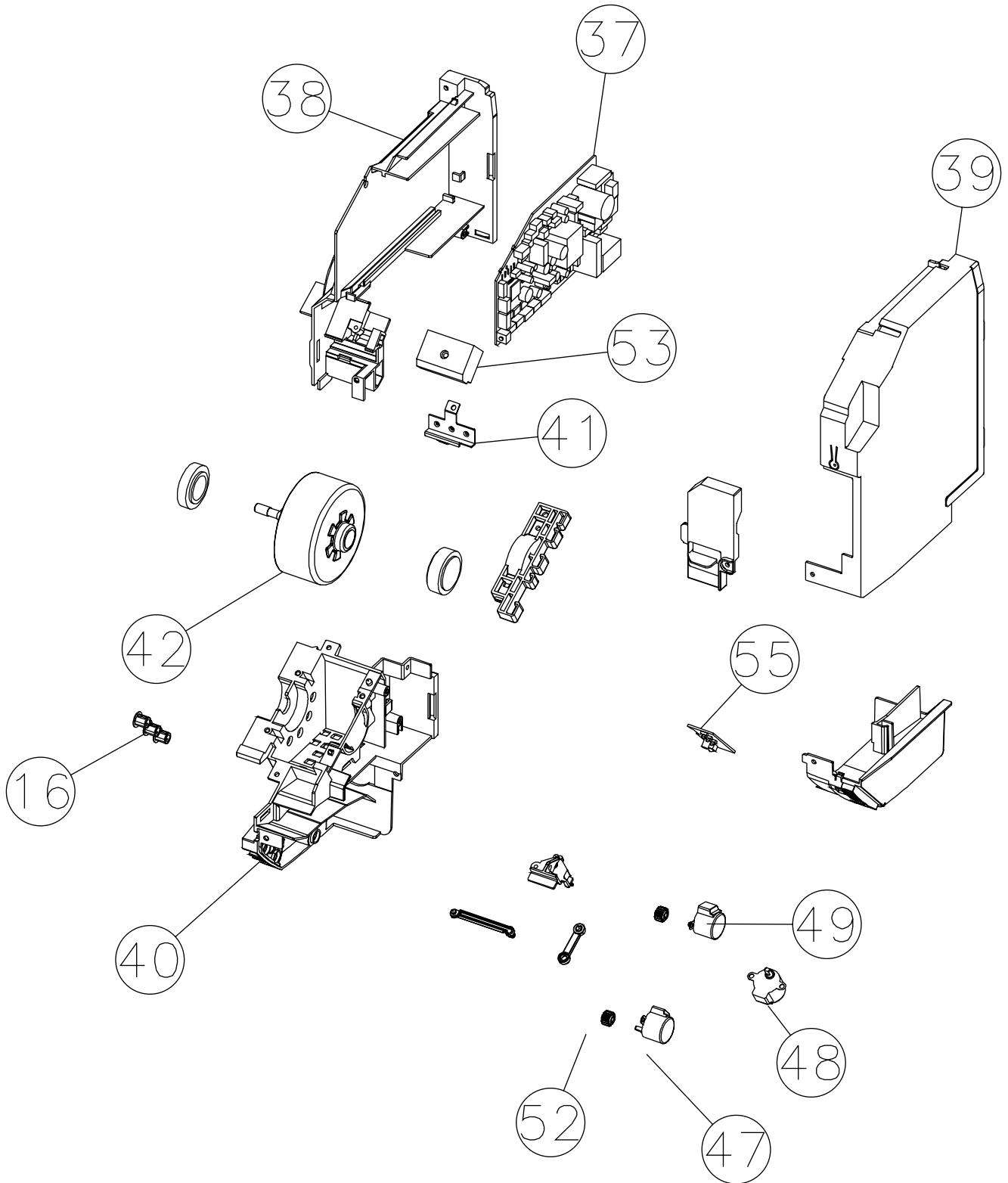

Model : MR30C3F

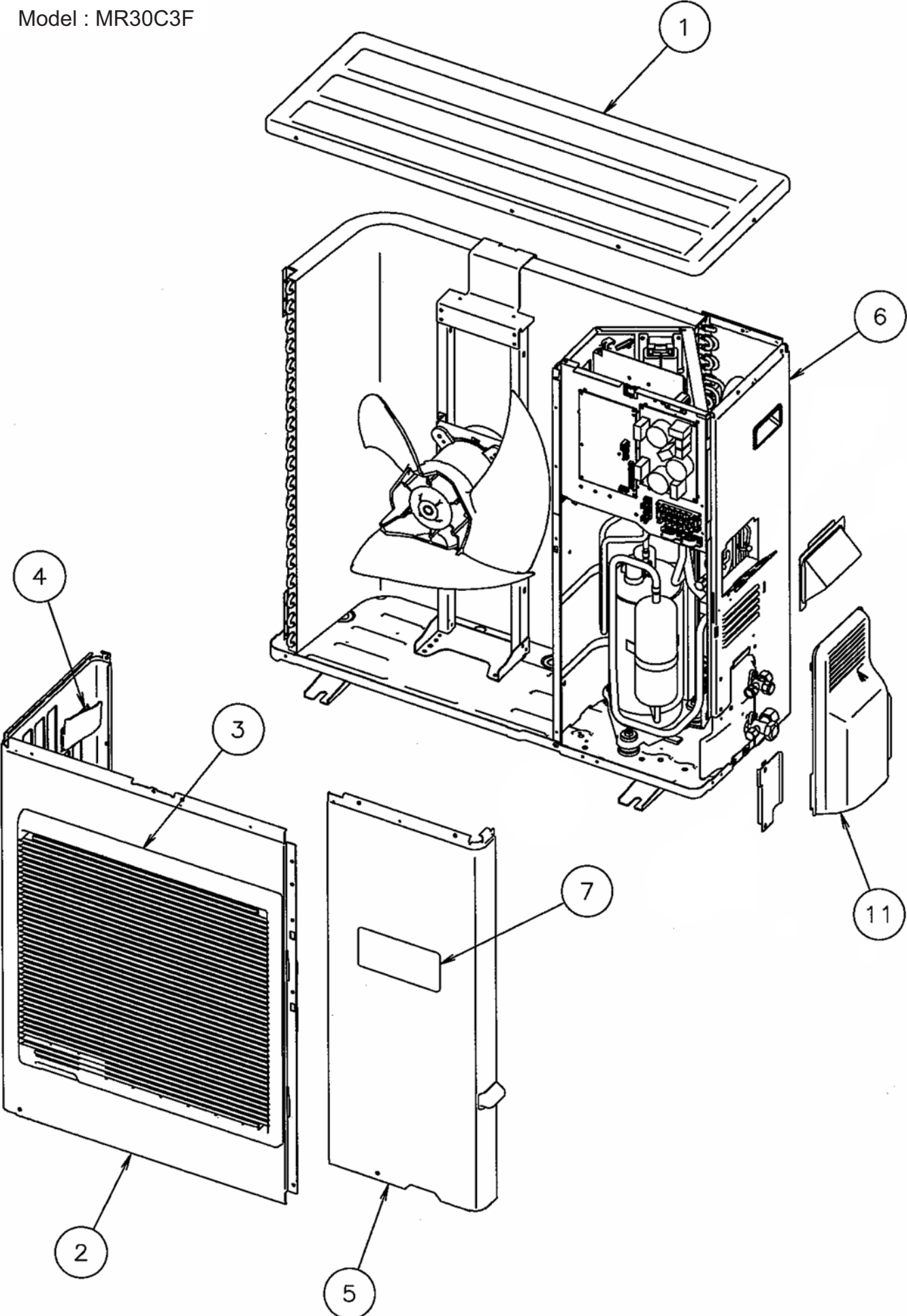

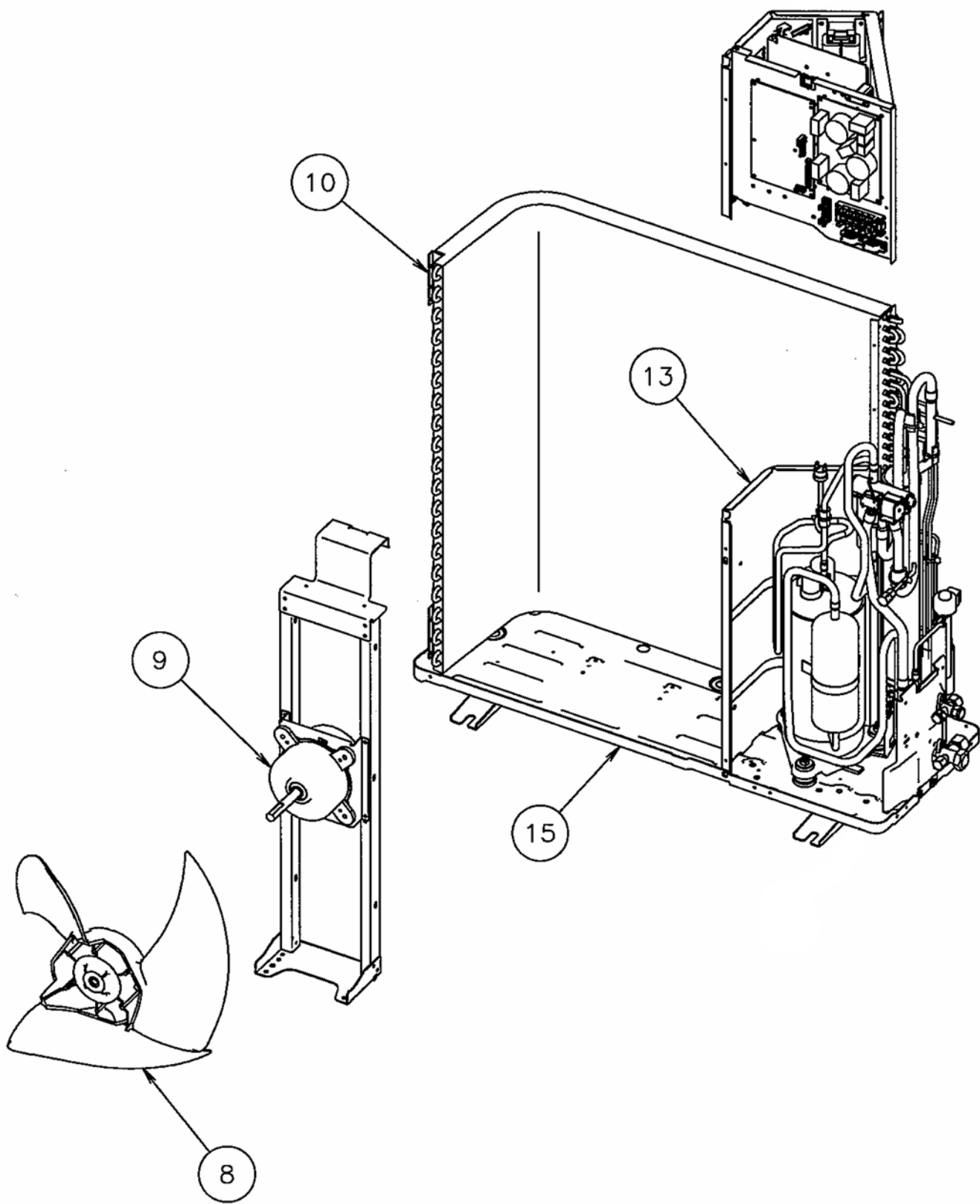

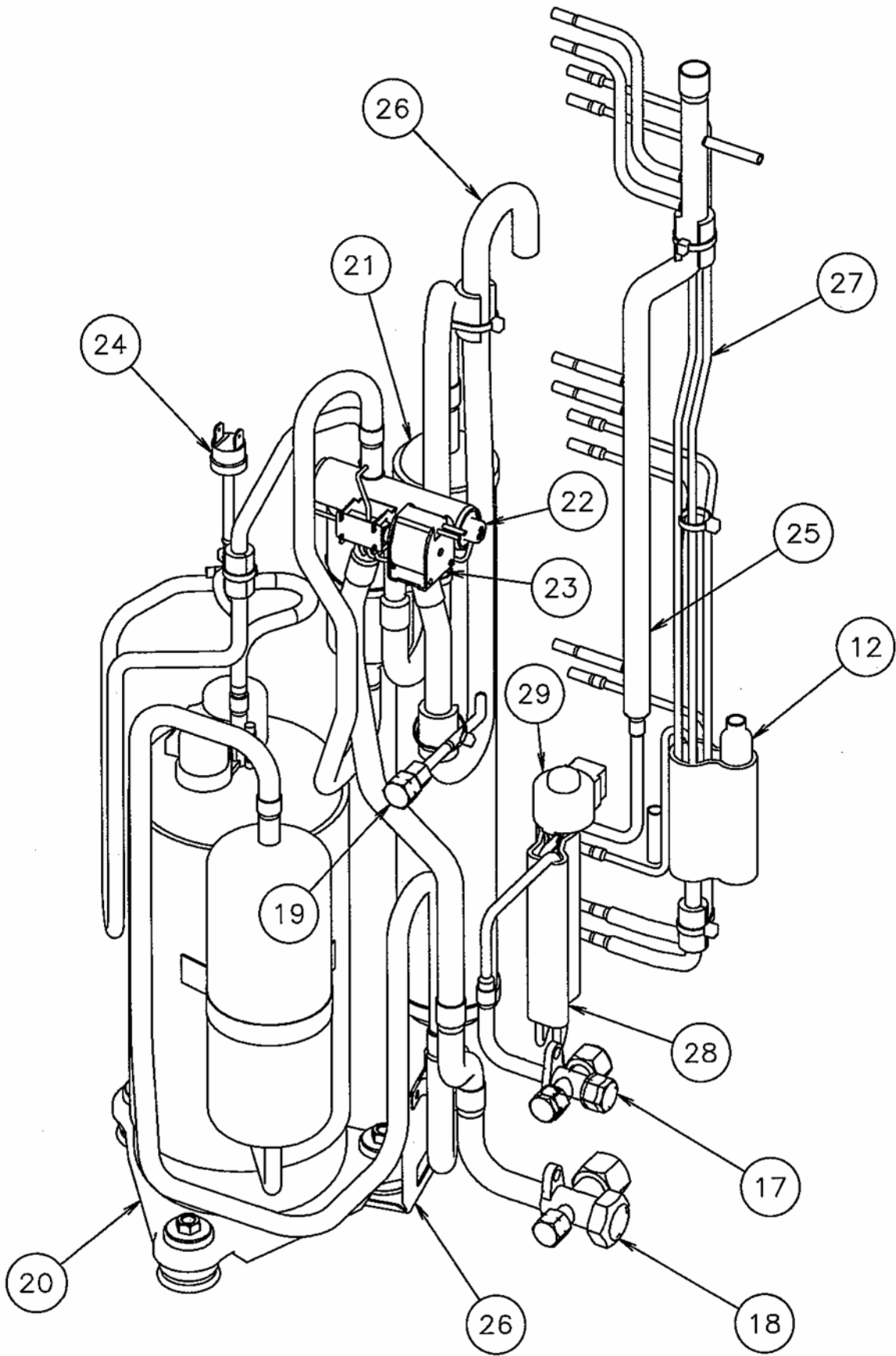

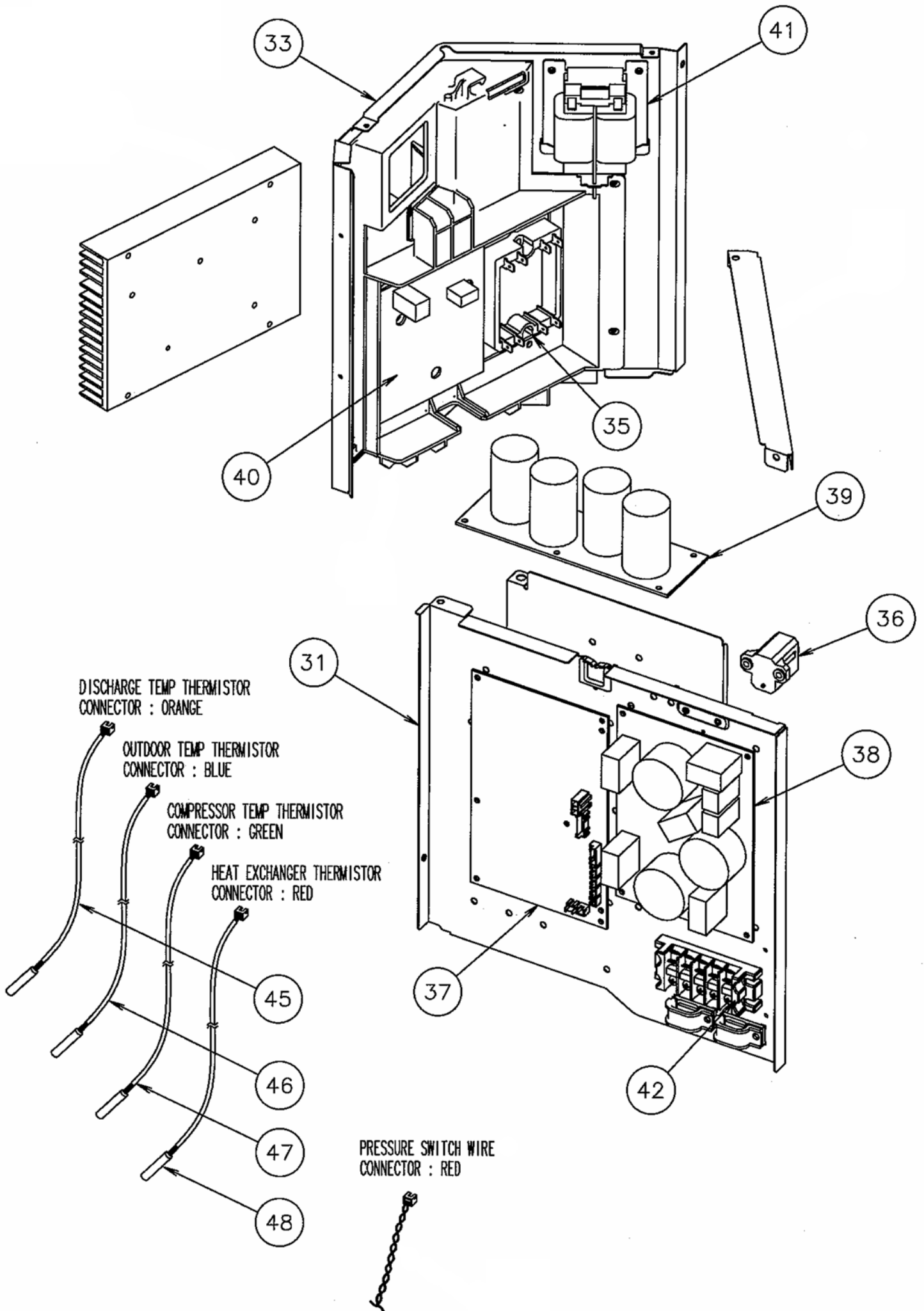

PARTS LIST







INDOOR UNIT

Ref. No.	Description	Part No.	Ord. Q'ty
		MW30C3F	
1	FRONT PANEL TOTAL ASSY	9315335081	
2	INTAKE GRILLE ASSY	9315336064	
4	AIR FILTER	9315014016	
5	CLAMPER(GRILLE)	9306755010	
6	RECEIVER WINDOW	9315010018	
8	CROSSFLOW FAN ASSY	9315024015	
9	BEARING C ASSY	9306628017	
10	CASING ASSY	9315331021	
22	R AND L LOUVER	9311997016	
23	SPACER B	9312441013	
25	EVAPORATOR ASSY C	9315789013	
26	DRAIN CAP	9367677009	
27	EVAPORATOR ASSY	9315348012	
28	EVAPORATOR ASSY B	9315349019	
29	CONNECTION PIPE ASSY	9315355010	
30	DISTRIBUTOR ASSY	9315351012	
31	WATER SEAL	9315251015	
32	EVAPORATER HOLDER R	9314994012	
33	EVAPORATER HOLDER L	9314995019	
34	REAR BRACKET	9315022011	
35	FILTER GUIDE	9315013019	
36	FILTER GUARD	9315411013	
37	Controller PCB ASSY	9707090093	
38	CONTROL BOX	9314996023	
39	CONTROL COVER	9314997020	
40	CASE(MOTOR)	9314998027	
41	TERMINAL(EARTH)	9315028013	
42	MOTOR,DC BRUSHLESS	9602163014	
46	MOTOR,STEP	9900384029	
47	MOTOR,STEP	9900384036	
48	MOTOR,STEP	9900139063	
52	GEAR A	9309994003	
53	TERMINAL	9900385019	
55	PWB ASSY(DISPLAY)	9707210019	

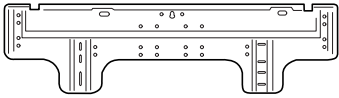
OUTDOOR UNIT

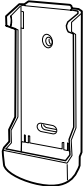
Ref. No.	Description	Part No.	Ord. Q'ty
		MR30C3F	
1	TOP PANEL SUB ASSY	9374417032	
2	FRONT PANEL M	9374094066	
3	FAN GUARD	9374330010	
4	GRIP SIDE	9374173013	
5	SERVICE PANEL SA	9374415052	
6	RIGHT PANEL	9374095148	
7	EMBLEM-REAR	9375212025	
8	PROPELLER FAN ASSY	9366378020	
9	MOTOR,DC BRUSHLESS	9602114016	
10	CONDENSER A ASSY	9374433148	
11	VALVE COVER	9374174010	
12	STRAINER ASSY	9372524015	
13	SEPA WALL W	9374413133	
15	BASE AS PTD	9374166138	
17	3-WAY VALVE ASSY	9372205044	
18	3-WAY VALVE ASSY	9372205075	
19	CHECK JOINT ASSY	9372802038	
20	COMPRESSOR ASSY	9372558126	
21	ACCUMULATOR	9385005006	
22	4-WAY VALVE	9900164010	
23	SOLENOID	9900165079	
24	PRESSURE SWITCH	9900186012	
25	INLET PIPE(COND)A ASSY	9373461067	
26	ACCUMULATOR SUPPORT ASSY	313986353804	
27	OUTLET PIPE(COND)A ASSY	9374266104	
28	EXPANSION VALVE ASSY	9370947144	
29	COIL(EXPANSION VALVE)	9900057039	
31	CASE(PWB)AS	9375316013	
33	CASE(INVERTER)	9375314019	
35	ACTPM	9703457012	
36	THERMISTOR	9704265012	
37	PWB ASSY	9707121063	
38	PWB ASSY	9707128062	
39	PWB ASSY	9707257014	
40	TR PWB ASSY	9707125085	
41	COIL,CHOKE	9900366018	
42	TERMINAL	9900203023	
45	DISCHARG TEMP THERMISTOR	9704219114	
46	THERMISTOR(OUTDOOR TEMP)	9900378028	
47	COMPRESSOR TEMP THERMISTOR	9900156022	
48	HEAT EXCHANGER THERMISTOR	9900374013	

STANDARD ACCESSORIES

Name and Shape	Part No.
Wall hook bracket 	9315023018
Remote control unit 	9315027160
Remote control unit holder 	9305642045
Battery (penlight) 	0600185534
Cloth tape 	9310519004
Tapping screw (big) 	0700076046
Tapping screw (small) 	0700019036

0602G3030