

SPLIT TYPE AIR CONDITIONER INSTALLATION INSTRUCTION SHEET

(PART NO. 9374747023)

For authorized service personnel only.

This installation instruction sheet describes how to install the outdoor unit only. To install the indoor unit, refer to the installation instruction sheet included with the indoor unit.



CAUTION

R410A REFRIGERANT

This Air Conditioner contains and operates with refrigerant R410A and Polyol Ester oil.

THIS PRODUCT MUST ONLY BE INSTALLED OR SERVICED BY QUALIFIED PERSONNEL.

Refer to Commonwealth, State, Territory and local legislation, regulations, codes, installation & operation manuals, before the installation, maintenance and/or service of this product.

**IMPORTANT!
Please Read Before Starting**

This air conditioning system meets strict safety and operating standards. As the installer or service person, it is an important part of your job to install or service the system so it operates safely and efficiently.

For safe installation and trouble-free operation, you must:

- Carefully read this instruction booklet before beginning.
- Follow each installation or repair step exactly as shown.
- Observe all local, state, and national electrical codes.
- Pay close attention to all danger, warning, and caution notices given in this manual.

WARNING: This symbol refers to a hazard or unsafe practice which can result in severe personal injury or death.

CAUTION: This symbol refers to a hazard or unsafe practice which can result in personal injury and the potential for product or property damage.

- Hazel alerting symbols

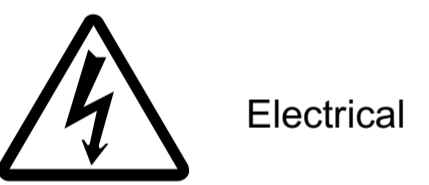

Electrical



Safety / alert

If Necessary, Get Help

These instructions are all you need for most installation sites and maintenance conditions. If you require help for a special problem, contact our sales/service outlet or your certified dealer for additional instructions.

In Case of Improper Installation

The manufacturer shall in no way be responsible for improper installation or maintenance service, including failure to follow the instructions in this document.

SPECIAL PRECAUTIONS

When Wiring

ELECTRICAL SHOCK CAN CAUSE SEVERE PERSONAL INJURY OR DEATH. ONLY A QUALIFIED, EXPERIENCED ELECTRICIAN SHOULD ATTEMPT TO WIRE THIS SYSTEM.

- Do not supply power to the unit until all wiring and tubing are completed or reconnected and checked.
- Highly dangerous electrical voltages are used in this system. Carefully refer to the wiring diagram and these instructions when wiring. Improper connections and inadequate grounding can cause accidental injury or death.
- Ground the unit following local electrical codes.
- Connect all wiring tightly. Loose wiring may cause overheating at connection points and a possible fire hazard.

When Transporting

Be careful when picking up and moving the indoor and outdoor units. Get a partner to help, and bend your knees when lifting to reduce strain on your back. Sharp edges or thin aluminum fins on the air conditioner can cut your fingers.

When Installing...

...In a Ceiling or Wall

Make sure the ceiling/wall is strong enough to hold the unit's weight. It may be necessary to construct a strong wood or metal frame to provide added support.

...In a Room

Properly insulate any tubing run inside a room to prevent sweating that can cause dripping and water damage to walls and floors.

...In Moist or Uneven Locations

Use a raised concrete pad or concrete blocks to provide a solid, level foundation for the outdoor unit. This prevents water damage and abnormal vibration.

...In an Area with High Winds

Securely anchor the outdoor unit down with bolts and a metal frame. Provide a suitable air baffle.

...In a Snowy Area (for Heat Pump-type Systems)

Install the outdoor unit on a raised platform that is higher than drifting snow. Provide snow vents.

When Connecting Refrigerant Tubing

- Keep all tubing runs as short as possible.
- Use the flare method for connecting tubing.
- Apply refrigerant lubricant to the matching surfaces of the flare and union tubes before connecting them, then tighten the nut with a torque wrench for a leak-free connection.
- Check carefully for leaks before starting the test run.

NOTE:

Depending on the system type, liquid and gas lines may be either narrow or wide. Therefore, to avoid confusion the refrigerant tubing for your particular model is specified as either small or large rather than as liquid or gas.

When Servicing

- Turn the power OFF at the main circuit breaker panel before opening the unit to check or repair electrical parts and wiring.
- Keep your fingers and clothing away from any moving parts.
- Clean up the site after you finish, remembering to check that no metal scraps or bits of wiring have been left inside the unit being serviced.
- After installation, explain correct operation to the customer, using the operating manual.

STANDARD PARTS

The following installation parts are furnished. Use them as required.

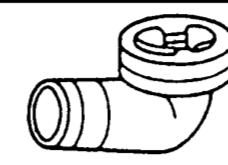
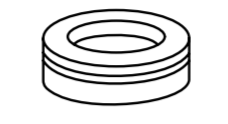
Name and Shape	Q ty	Application
	1	For outdoor unit drain piping work (May not be supplied, depending on the model.)
	5	

GENERAL

This INSTALLATION INSTRUCTION SHEET briefly outlines where and how to install the air conditioning system. Please read over the entire set of instructions for the indoor and outdoor units and make sure all accessory parts listed are with the system before beginning.

CONNECTION PIPE REQUIREMENT

CAUTION

The maximum lengths of this product are shown in the following table. If the units are further apart than this, correct operation can not be guaranteed.

Model Type	Diameter		Pipe length		Maximum height (between indoor and outdoor)
	Liquid	Gas	MAX.	MIN.	
24,000 BTU/h class	9.52 mm (3/8 in.)	15.88 mm (5/8 in.)	50 m (165 ft)	5 m (16 ft)	20 m (66 ft)
36,000 BTU/h class	9.52 mm (3/8 in.)	15.88 mm (5/8 in.)	50 m (165 ft)	5 m (16 ft)	30 m (98 ft)

Use pipe with water-resistant heat insulation.

CAUTION

Install heat insulation around both the gas and liquid pipes. Failure to do so may cause water leaks. Use heat insulation with heat resistance above 248 °F. (Reverse cycle model only) In addition, if the humidity level at the installation location of the refrigerant piping is expected to exceed 70%, install heat insulation around the refrigerant piping. If the expected humidity level is 70-80%, use heat insulation that is 15 mm (19/32") or thicker and if the expected humidity exceeds 80%, use heat insulation that is 20 mm (13/16") or thicker. If heat insulation is used that is not as thick as specified, condensation may form on the surface of the insulation. In addition, use heat insulation with heat conductivity of 0.045 W/(m·K) or less (at 68 °F).

ADDITIONAL MATERIALS REQUIRED FOR INSTALLATION

- (1) Refrigeration (armored) tape
- (2) Insulated staples or clamps for connecting wire (See your local electrical codes.)
- (3) Putty
- (4) Refrigeration lubricant
- (5) Clamps or saddles to secure refrigerant piping

OPERATING RANGE

		Temperature	Indoor air intake	Outdoor air intake
24,000 BTU/h class	Cooling	Maximum	90 °F DB	115 °F DB
		Minimum	65 °F DB	0 °F DB
36,000 BTU/h class	Heating	Maximum	86 °F DB or less	75 °F DB
		Minimum	"	14 °F DB

Indoor humidity about 80% or less

⚠ DANGER

Never touch electrical components immediately after the power supply has been turned off. Electrical shock may occur. After turning off the power, always wait 5 minutes or more before touching electrical components.

This air conditioner uses new refrigerant HFC (R410A).

The basic installation work procedures are the same as conventional refrigerant models. However, pay careful attention to the following points:

- 1 Since the working pressure is 1.6 times higher than that of conventional refrigerant models, some of the piping and installation and service tools are special. (See the table below.) Especially, when replacing a conventional refrigerant model with a new refrigerant R410A model, always replace the conventional piping and flare nuts with the R410A piping and flare nuts.
- 2 Models that use refrigerant R410A have a different charging port thread diameter to prevent erroneous charging with conventional refrigerant and for safety. Therefore, check beforehand. [The charging port thread diameter for R410A is 1/2 UNF 20 threads per inch.]
- 3 Be more careful that foreign matter (oil, water, etc.) does not enter the piping than with refrigerant models. Also, when storing the piping, securely seal the openings by pinching, taping, etc.
- 4 When charging the refrigerant, take into account the slight change in the composition of the gas and liquid phases, and always charge from the liquid phase side whose composition is stable.

Special tools for R410A

Tool name	Contents of change
Gauge manifold	Pressure is high and cannot be measured with a conventional gauge. To prevent erroneous mixing of other refrigerants, the diameter of each port has been changed. It is recommended the gauge with seals ...0.1 to 5.3 MPa (...76 cmHg to 53 kgf/cm ²) for high pressure ...0.1 to 3.8 MPa (...76 cmHg to 38 kgf/cm ²) for low pressure.
Charge hose	To increase pressure resistance, the hose material and base size were changed.
Vacuum pump	A conventional vacuum pump can be used by installing a vacuum pump adapter.
Gas leakage detector	Special gas leakage detector for HFC refrigerant R410A.

Copper pipes

It is necessary to use seamless copper pipes and it is desirable that the amount of residual oil is less than 40 mg/10 m. Do not use copper pipes having a collapsed, deformed or discolored portion (especially on the interior surface). Otherwise, the expansion valve or capillary tube may become blocked with contaminants. As an air conditioner using R410A incurs pressure higher than when using conventional refrigerant, it is necessary to choose adequate materials. Thicknesses of copper pipes used with R410A are as shown in the table. Never use copper pipes thinner than that in the table even when it is available on the market.

Thicknesses of Annealed Copper Pipes (R410A)

Pipe outside diameter	Thickness
6.35 mm (1/4 in.)	0.80 mm (0.0315 in.)
9.52 mm (3/8 in.)	0.80 mm (0.0315 in.)
12.70 mm (1/2 in.)	0.80 mm (0.0315 in.)
15.88 mm (5/8 in.)	1.00 mm (0.0394 in.)

⚠ WARNING

- 1 For the air conditioner to operate satisfactorily, install it as outlined in this installation instruction sheet.
- 2 Connect the indoor unit and outdoor unit with the room air conditioner piping and cords available standards parts. This installation instruction sheet describes the correct connections using the installation set available from our standard parts.
- 3 Installation work must be performed in accordance with national wiring standards by authorized personnel only.
- 4 Also, do not use an extension cord.
- 5 Do not turn on the power until all installation work is complete.
- 6 Do not purge the air with refrigerants but use a vacuum pump to vacuum the installation.
- 7 There is not extra refrigerant in the outdoor unit for air purging.
- 8 Use a vacuum pump for R410A exclusively.
- 9 Using the same vacuum pump for different refrigerants may damage the vacuum pump or the unit.
- 10 Use a clean gauge manifold and charging hose for R410A exclusively.
- 11 If refrigerant leaks while work is being carried out, ventilate the area. If the refrigerant comes in contact with a flame, it produces a toxic gas.

- Be careful not to scratch the air conditioner when handling it.
- After installation, explain correct operation to the customer, using the operating manual.
- Let the customer keep this installation instruction sheet because it is used when the air conditioner is serviced or moved.

ELECTRICAL REQUIREMENT

Always make the air conditioner power supply a special branch circuit and provide a special switch and receptacle. Do not extend the power cord.

	MINIMUM CIRCUIT AMPACTIY	MAXIMUM OVERCURRENT PROTECTION (TIME DELAY FUSE OR HACR TYPE CIRCUIT BREAKER)
24,000 BTU/h class	15.5 A	20 A
36,000 BTU/h class	23.0 A	30 A

SELECTING THE MOUNTING POSITION

Decide the mounting position with the customer as follows:

⚠ WARNING

Select installation locations that can properly support the weight of the indoor and outdoor units. Install the units securely so that they do not topple or fall.

⚠ CAUTION

- 1 Do not install where there is the danger of combustible gas leakage.
- 2 Do not install the unit near heat source of heat, steam, or flammable gas.
- 3 If children under 10 years old may approach the unit, take preventive measures so that they cannot reach the unit.

⚠ WARNING

- 1 Install the unit where it will not be tilted by more than 3°. However, do not install the unit with it tilted towards the side containing the compressor.
- 2 When installing the outdoor unit where it may exposed to strong wind, fasten it securely.

- (1) Install the outdoor unit in a location which can withstand the weight of the unit and vibration, and which can install horizontally.
- (2) Provide the indicated space to ensure good airflow.
- (3) If possible, do not install the unit where it will be exposed to direct sunlight. (If necessary, install a blind that does not interfere with the airflow.)
- (4) Do not install the unit near a source of heat, steam, or flammable gas.
- (5) During heating operation, drain water flows from the outdoor unit. Therefore, install the outdoor unit in a place where the drain water flow will not be obstructed. (Reverse cycle model only)
- (6) Do not install the unit where strong wind blows or where it is very dusty.
- (7) Do not install the unit where people pass.
- (8) Install the outdoor unit in a place where it will be free from being dirty or getting wet by rain as much as possible.
- (9) Install the unit where connection to the indoor unit is easy.

- 24,000 BTU/h class
- 36,000 BTU/h class

When there are obstacles at the back side.

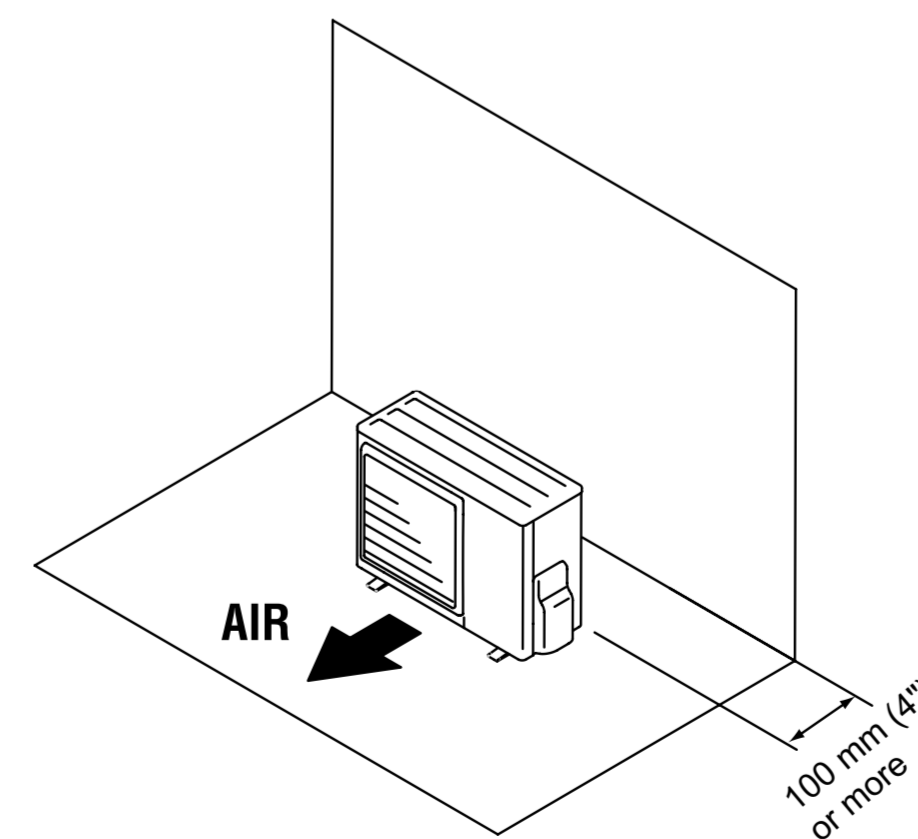

When there are obstacles at the back and front sides.

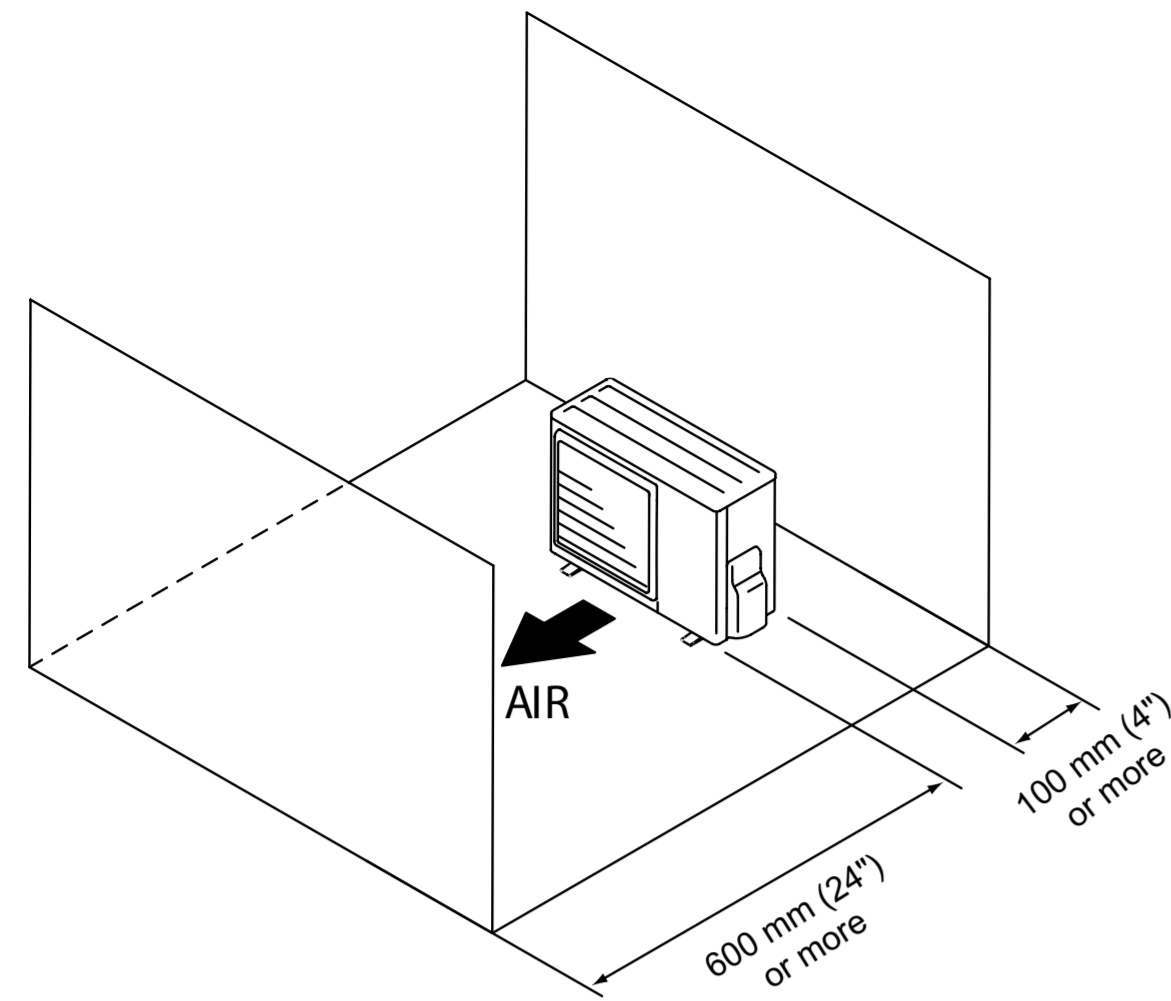

When there are obstacles at the back, side(s), and top.

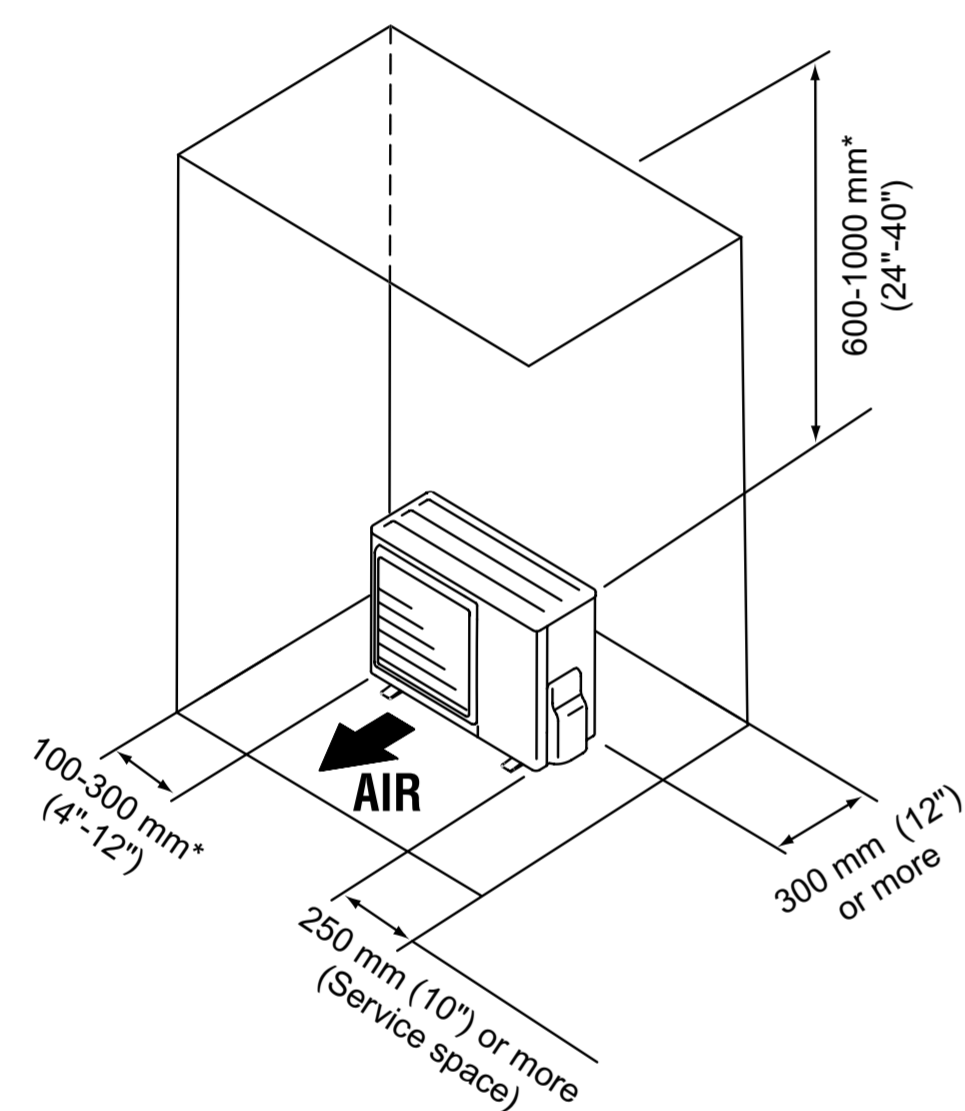

When there are obstacles at the back side with the installation of more than one unit.

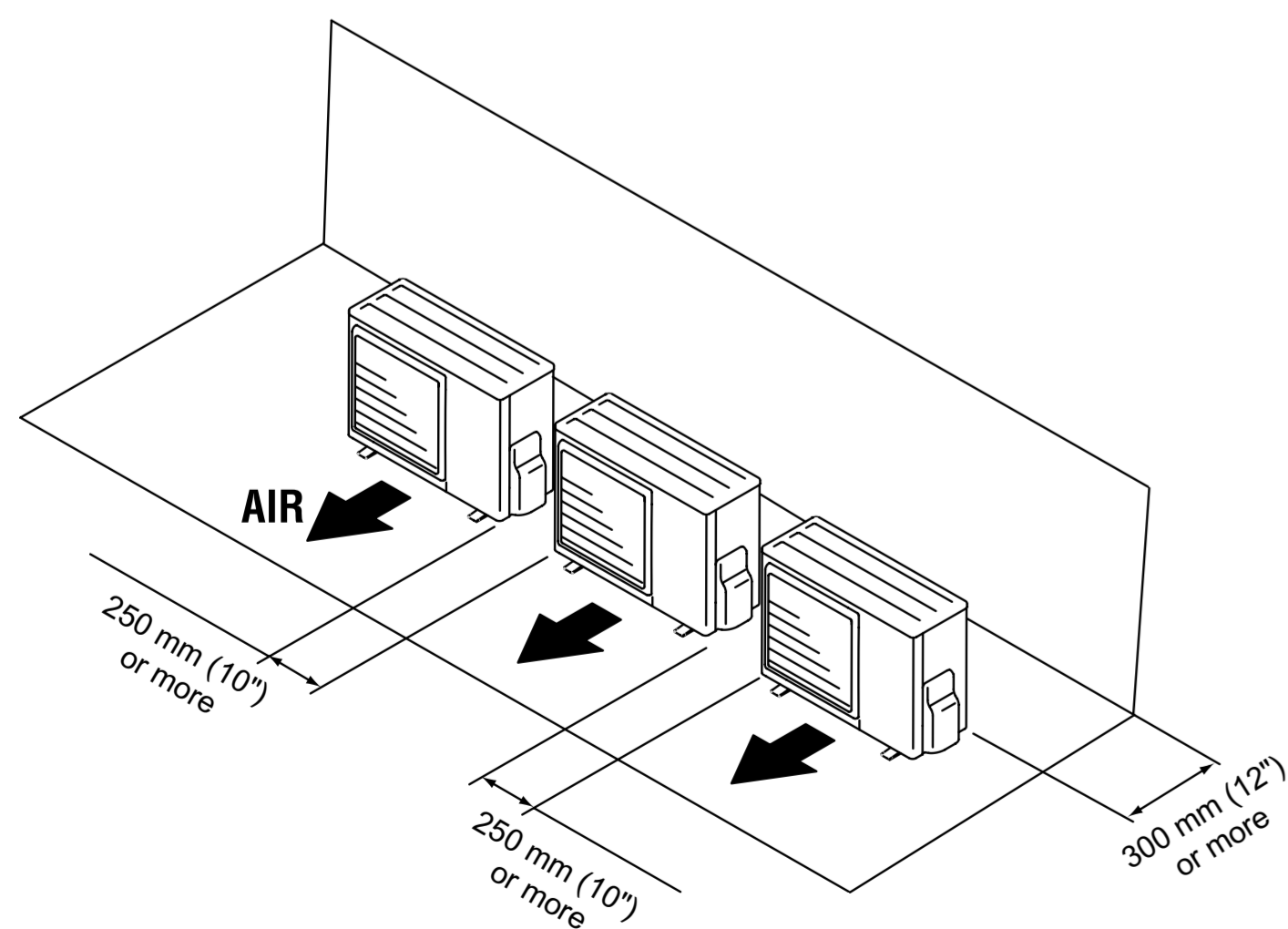

* If the space is larger than that is stated, the condition will be the same as that there are no obstacles.

INSTALLATION PROCEDURE

1

OUTDOOR UNIT INSTALLATION

1. OUTDOOR UNIT PROCESSING

(1) Outdoor unit to be fasten with bolts at the four places indicated by the arrows without fail.

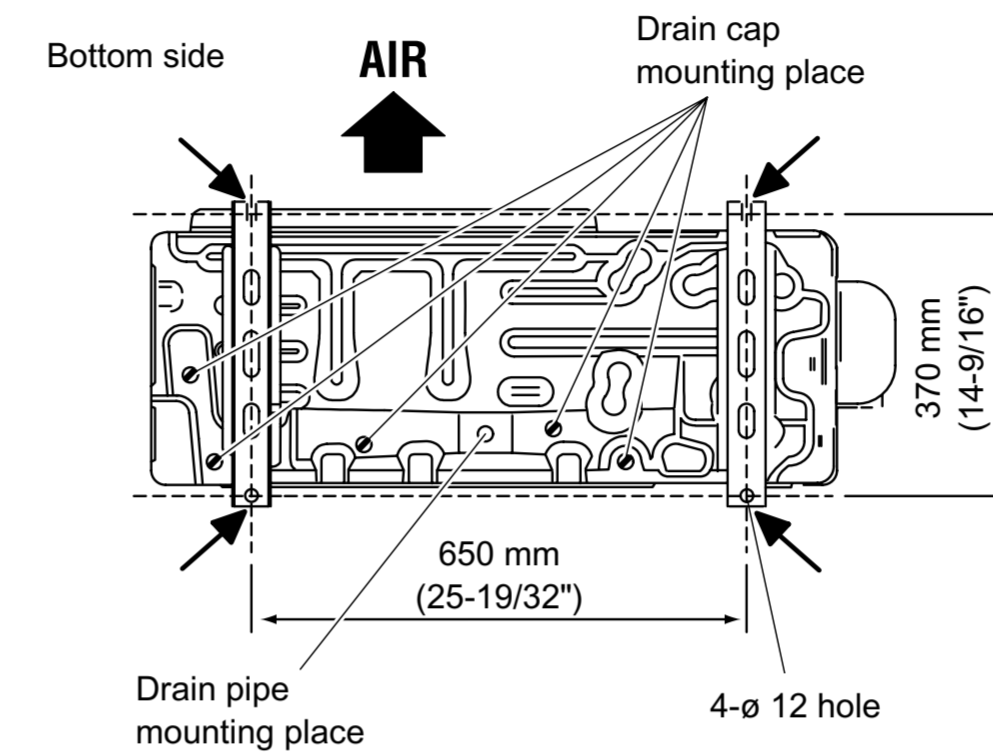

(2) Fix securely with bolts on a solid block. (Use 4 sets of commercially available M10 bolt, nut and washer.)

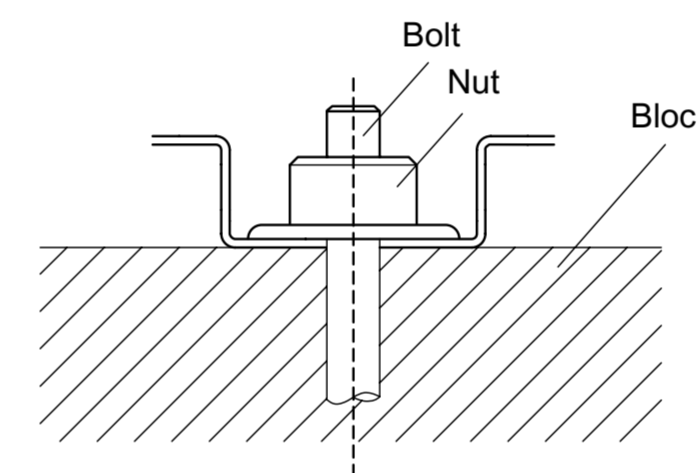

(3) Since the drain water flows out of the outdoor unit during heating operation, install the drain pipe and connect it to a commercial 16 mm (5/8") hose. (Reverse cycle model only)

(4) When installing the drain pipe, plug all the holes other than the drain pipe mounting hole in the bottom of the outdoor unit with putty so there is no water leakage. (Reverse cycle model only)

CAUTION

When the outdoor temperature is 32 °F or less, do not use the accessory drain pipe and drain cap. If the drain pipe and drain cap are used, the drain water in the pipe may freeze in extremely cold weather. (Reverse cycle model only)

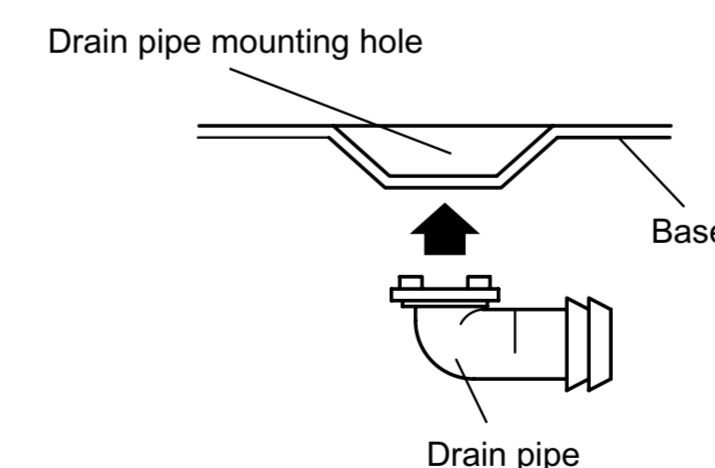

2

CONNECTING THE PIPE

CAUTION

- Do not use mineral oil on flared part. Prevent mineral oil from getting into the system as this would reduce the lifetime of the units.
- While welding the pipes, be sure to blow dry nitrogen gas through them.
- The maximum lengths of this product are shown in the table. If the units are further apart than this, correct operation can not be guaranteed.

1. FLARING

- Cut the connection pipe to the necessary length with a pipe cutter.
- Hold the pipe downward so that cuttings will not enter the pipe and remove the burrs.
- Insert the flare nut (always use the flare nut attached to the indoor and outdoor units respectively) onto the pipe and perform the flare processing with a flare tool. Use the special R410A flare tool, or the conventional flare tool.

Check if [L] is flared uniformly and is not cracked or scratched.

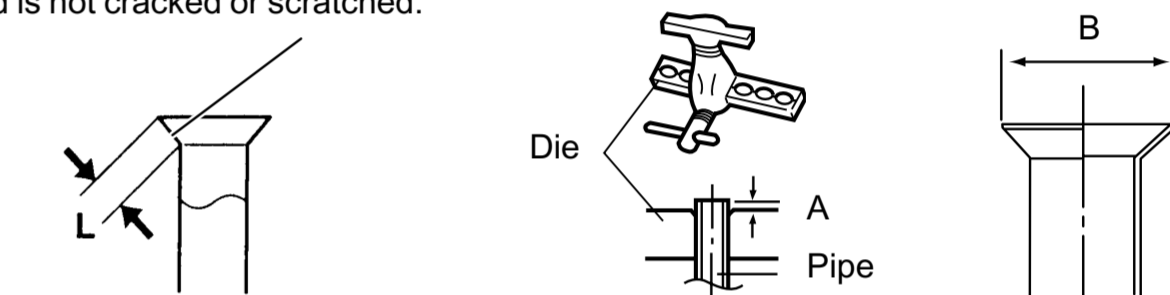

Pipe outside diameter	Dimension A
	Flare tool for R410A, clutch type
6.35 mm (1/4 in.)	0 to 0.5 mm (0 to 0.0197 in.)
9.52 mm (3/8 in.)	
12.70 mm (1/2 in.)	
15.88 mm (5/8 in.)	

Pipe outside diameter	Dimension B $^{+0.4}$
6.35 mm (1/4 in.)	9.1 mm (0.3583 in.)
9.52 mm (3/8 in.)	13.2 mm (0.5197 in.)
12.70 mm (1/2 in.)	16.6 mm (0.6536 in.)
15.88 mm (5/8 in.)	19.7 mm (0.7756 in.)

When using conventional flare tools to flare R410A pipes, the dimension A should be approximately 0.5 mm (1/32") more than indicated in the table (for flaring with R410A flare tools) to achieve the specified flaring. Use a thickness gauge to measure the dimension A.

Width across flats

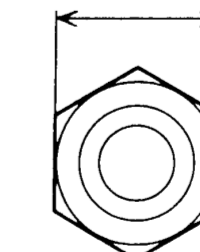

Pipe outside diameter	Width across flats of Flare nut
6.35 mm (1/4 in.)	17 mm (0.6693 in.)
9.52 mm (3/8 in.)	22 mm (0.8661 in.)
12.70 mm (1/2 in.)	26 mm (1.0236 in.)
15.88 mm (5/8 in.)	29 mm (1.1417 in.)

2. BENDING PIPES

The pipes are shaped by your hands. Be careful not to collapse them. Do not bend the pipes in an angle more than 90°.

When pipes are repeatedly bend or stretched, the material will harden, making it difficult to bend or stretch them any more. Do not bend or stretch the pipes more than three times.

CAUTION

- To prevent breaking of the pipe, avoid sharp bends. Bend the pipe with a radius of curvature of 150 mm (6") or over.
- If the pipe is bent repeatedly at the same place, it will break.

3. CONNECTION PIPES

Outdoor unit

- Detach the caps and plugs from the pipes.

CAUTION

- Be sure to apply the pipe against the port on the indoor unit and the outdoor unit correctly. If the centering is improper, the flare nut cannot be tightened smoothly. If the flare nut is forced to turn, the threads will be damaged.
- Do not remove the flare nut from the indoor unit pipe until immediately before connecting the connection pipe.

- Centering the pipe against port on the outdoor unit, turn the flare nut with your hand.

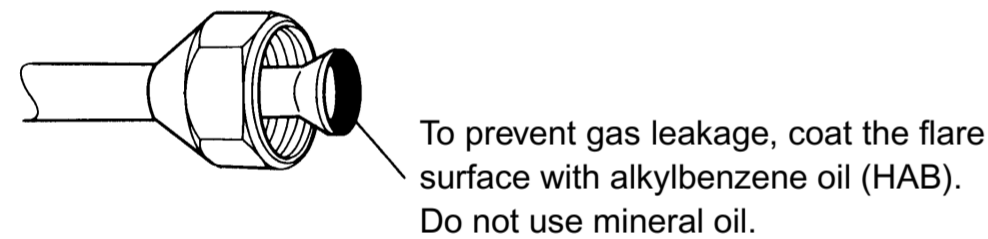

- Tighten the flare nut of the connection pipe at the outdoor unit valve connector.

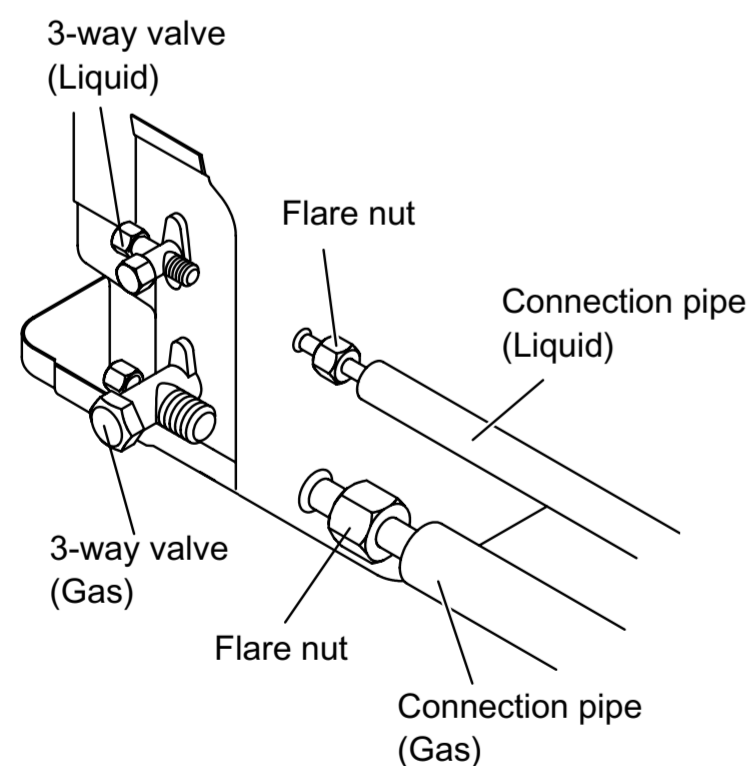

- When the flare nut is tightened properly by your hand, use a torque wrench to finally tighten it.

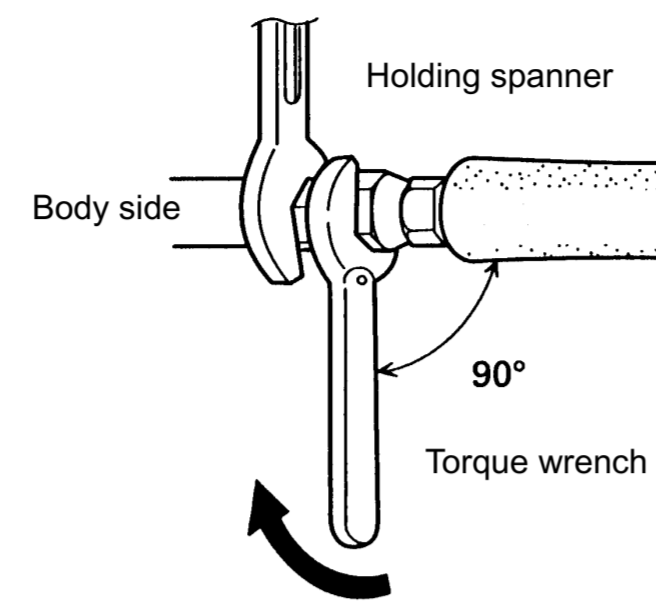

CAUTION

Hold the torque wrench at its grip, keeping it in the right angle with the pipe, in order to tighten the flare nut correctly.

Flare nut	Tightening torque
6.35 mm (1/4 in.) dia.	16 to 18 N·m (160 to 180 kgf·cm)
9.52 mm (3/8 in.) dia.	30 to 42 N·m (300 to 420 kgf·cm)
12.70 mm (1/2 in.) dia.	49 to 61 N·m (490 to 610 kgf·cm)
15.88 mm (5/8 in.) dia.	63 to 75 N·m (630 to 750 kgf·cm)

4. VACUUM

- Remove the cap, and connect the gauge manifold and the vacuum pump to the charging valve by the service hoses.
- Vacuum the indoor unit and the connecting pipes until the pressure gauge indicates ...0.1 MPa (...76 cmHg).
- When ...0.1 MPa (...76 cmHg) is reached, operate the vacuum pump for at least 60 minutes.
- Disconnect the service hoses and fit the cap to the charging valve to the specified torque.
- Remove the blank caps, and fully open the spindles of the 2-way and 3-way valves with a hexagon wrench [Torque: 6~7 N·m (60 to 70 kgf·cm)].
- Tighten the blank caps of the 2-way valve and 3-way valve to the specified torque.

		Tightening torque
Blank cap	6.35 mm (1/4 in.)	20 to 25 N·m (200 to 250 kgf·cm)
	9.52 mm (3/8 in.)	20 to 25 N·m (200 to 250 kgf·cm)
	12.70 mm (1/2 in.)	25 to 30 N·m (250 to 300 kgf·cm)
	15.88 mm (5/8 in.)	30 to 35 N·m (300 to 350 kgf·cm)
Charging port cap		10 to 12 N·m (100 to 120 kgf·cm)

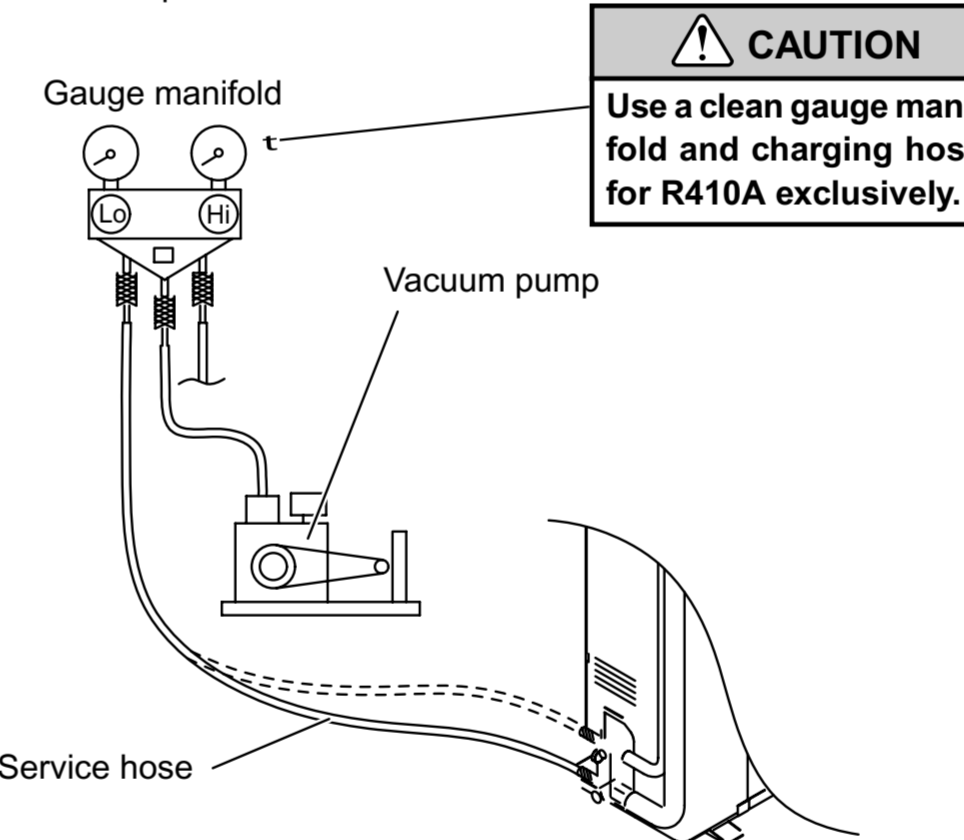
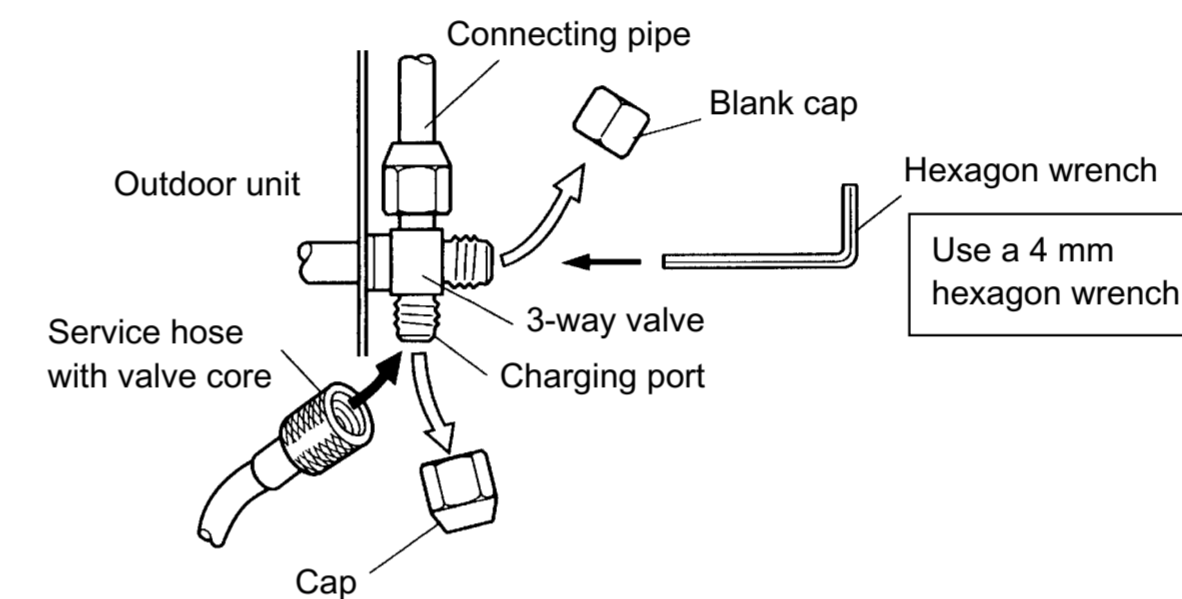

CAUTION

- Do not purge the air with refrigerants, but use a vacuum pump to vacuum the installation! There is no extra refrigerant in the outdoor unit for air purging!
- Use a vacuum pump and gauge manifold and charging hose for R410A exclusively. Using the same vacuum for different refrigerants may damage the vacuum pump or the unit.

5. ADDITIONAL CHARGE

- 24,000 BTU/h class
 - 36,000 BTU/h class
- Refrigerant suitable for a piping length of 15 m (49 ft) is charged in the outdoor unit at the factory. When the piping is longer than 15 m (49 ft), additional charging is necessary. For the additional amount, see the table below.

Model type	Pipe length					
	49 ft (15 m)	66 ft (20 m)	98 ft (30 m)	131 ft (40 m)	164 ft (50 m)	oz/ft
24,000 BTU/h class	None	7.1 oz (200 g)	1 lb 5 oz (600 g)	2 lb 3 oz (1000 g)	3 lb 1 oz (1400 g)	1.4 oz/3.3 ft (40 g/m)
36,000 BTU/h class	None	7.1 oz (200 g)	1 lb 5 oz (600 g)	2 lb 3 oz (1000 g)	3 lb 1 oz (1400 g)	1.4 oz/3.3 ft (40 g/m)

CAUTION

- When moving and installing the air conditioner, do not mix gas other than the specified refrigerant R410A inside the refrigerant cycle.
- When charging the refrigerant R410A, always use an electronic balance for refrigerant charging (to measure the refrigerant by weight).
- When charging the refrigerant, take into account the slight change in the composition of the gas and liquid phases, and always charge from the liquid phase side whose composition is stable.
- Add refrigerant from the charging valve after the completion of the work.
- If the units are further apart than the maximum pipe length, correct operation can not be guaranteed.

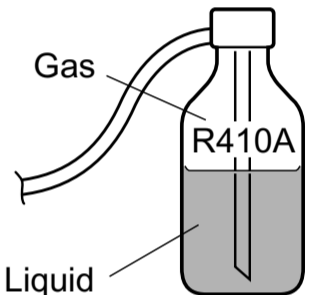

6. GAS LEAKAGE INSPECTION

CAUTION

- After connecting the piping, check the all joints for gas leakage with gas leak detector.
- When inspecting gas leakage, always use the vacuum pump for pressure. Do not use nitrogen gas.

WARNING

- 1 The rated voltage of this product is 230/208 V a.c. 60 Hz.
- 2 Before turning on, verify that the voltage is within the 187 V to 253 V range.
- 3 Always use a special branch circuit and install a special receptacle to supply power to the air conditioner.
- 4 Use a special branch circuit breaker and receptacle matched to the capacity of the air conditioner. (Install in accordance with standard.)
- 5 Perform wiring work in accordance with standards so that the air conditioner can be operated safely and positively.
- 6 Install a leakage special branch circuit breaker in accordance with the related laws and regulations and electric company standards.
- 7 The circuit breaker is installed in the permanent wiring. Always use a circuit that can trip all the poles of the wiring and has an isolation distance of at least 3 mm (1/8") between the contacts of each pole.

CAUTION

- 1 The power source capacity must be the sum of the air conditioner current and the current of other electrical appliances. When the current contracted capacity is insufficient, change the contracted capacity.
- 2 When the voltage is low and the air conditioner is difficult to start, contact the power company the voltage raised.

WARNING

- 1 Before starting work, check that power is not being supplied to the indoor unit and outdoor unit.
- 2 Match the terminal board numbers and connection cord colors with those of the outdoor unit. Erroneous wiring may cause burning of the electric parts.
- 3 Connect the connection cords firmly to the terminal board. Imperfect installation may cause a fire.
- 4 Always fasten the outside covering of the connection cord with the cord clamp. (If the insulator is chafed, electric leakage may occur.)
- 5 Always connect the ground wire.

HOW TO CONNECT WIRING TO THE TERMINALS**A. For solid core wiring**

- (1) Cut the wire end with a wire cutter or wire-cutting pliers, then strip the insulation to about 25 mm (31/32") to expose the solid wire.
- (2) Using a screwdriver, remove the terminal screw(s) on the terminal board.
- (3) Using pliers, bend the solid wire to form a loop suitable for the terminal screw.
- (4) Shape the loop wire properly, place it on the terminal board and tighten securely with the terminal screw using a screwdriver.

B. For strand wiring

- (1) Cut the wire end with a wire cutter or wire-cutting pliers, then strip the insulation to about 10 mm (13/32") to expose the strand wiring.
- (2) Using a screwdriver, remove the terminal screw(s) on the terminal board.
- (3) Using a round terminal fastener or pliers, securely clamp a round terminal to each stripped wire end.
- (4) Position the round terminal wire, and replace and tighten the terminal screw using a screwdriver.

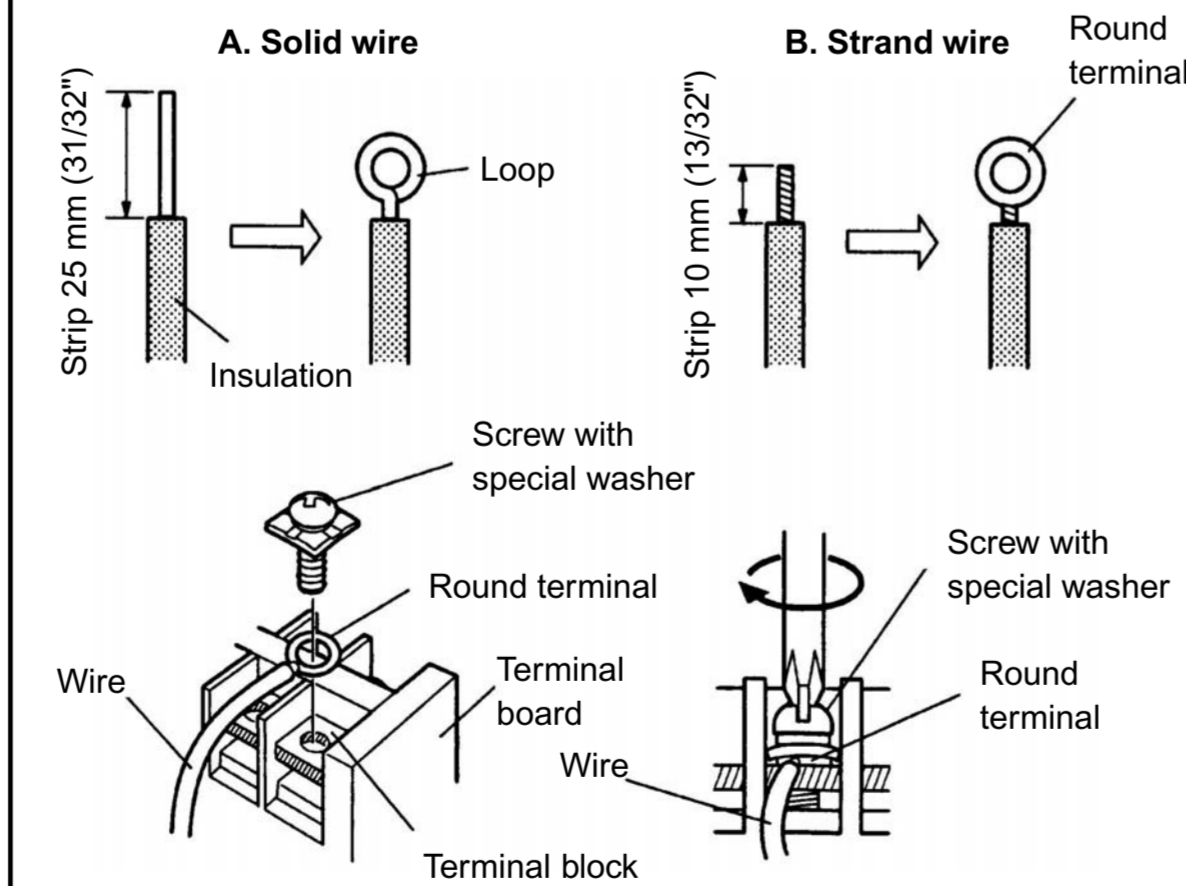
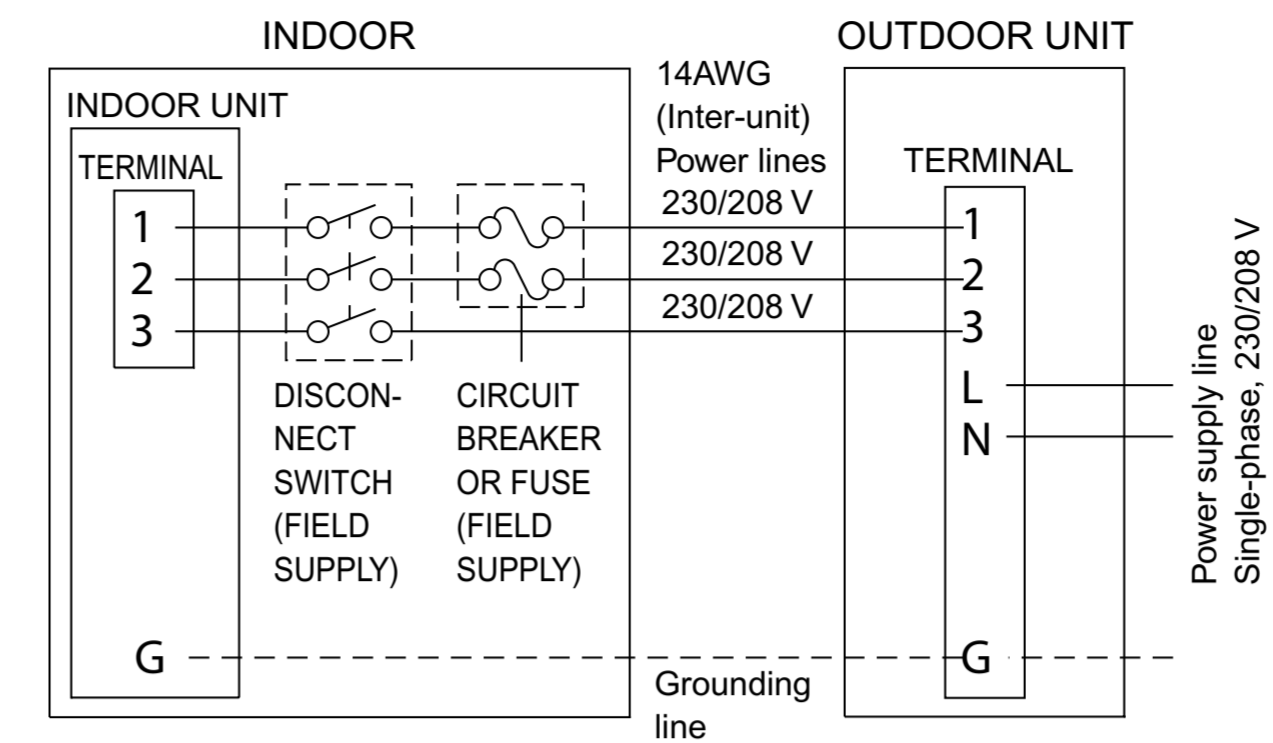
**1. CONNECTION DIAGRAMS****WARNING**

Disconnect switch and circuit breaker for over current protection given in the table below is to be installed between the indoor unit and the outdoor unit.

Disconnect switch	Circuit breaker (or Fuse)
15A	240 V - 5A

CAUTION

- 1 Be sure to refer the above diagram and do correct field wiring. Wrong wiring causes malfunction of the unit.
- 2 Check local electrical codes and also any specific wiring instructions or limitation.

2. CONNECTION CORD PREPARATION

Keep the earth wire longer than the other wires.

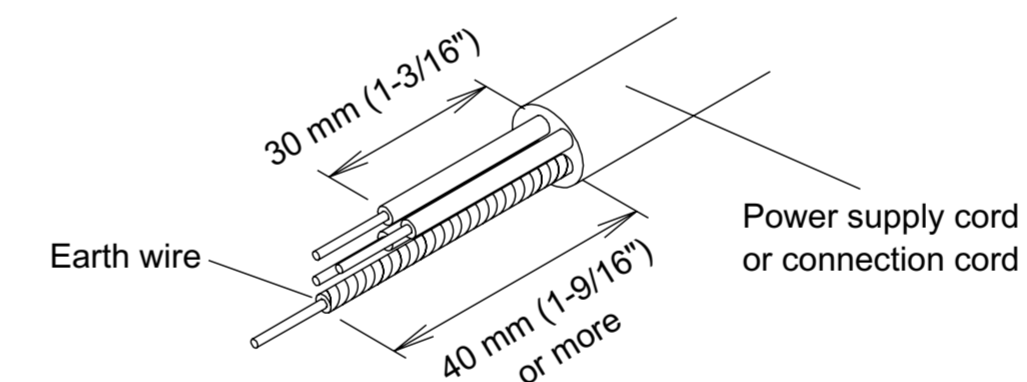
**3. OUTDOOR UNIT****CAUTION**

When connecting the power supply cord, make sure that the phase of the power supply matches with the phase of the terminal board. If the phases do not match, the compressor will rotate in reverse and will not be able to compress.

- (1) Service cover removal
 - Remove the two mounting screws.
 - Remove the service cover by pushing downwards.

- 18,000 BTU/h class
- 24,000 BTU/h class
- 36,000 BTU/h class

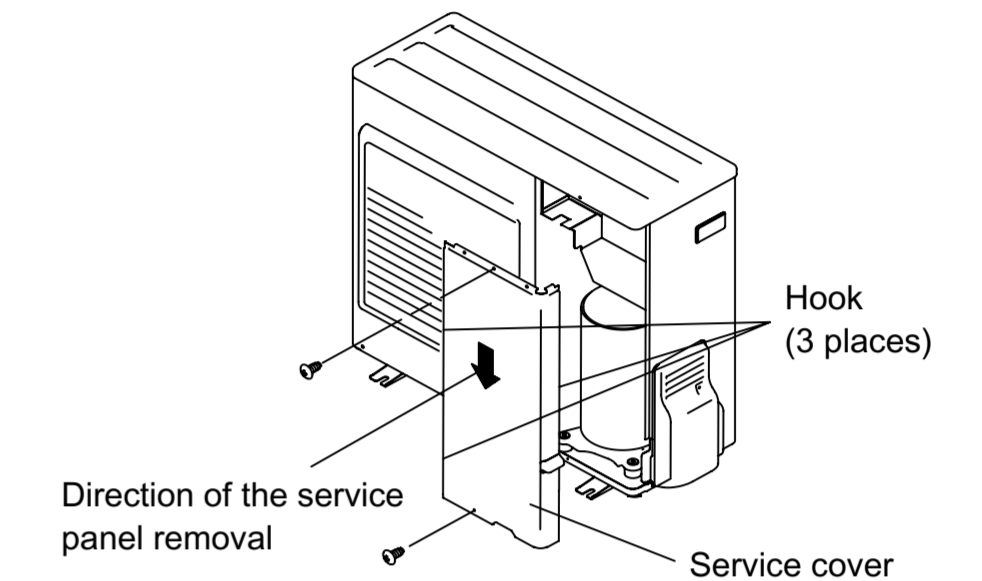

- (2) Fasten the power supply cord and the connection cord to the conduit holder using the lock nut. (open the knock out holes if necessary)
- (3) Connect the power supply cord and the connection cord to terminal.
- (4) Fasten the power supply cord and connection cord with cord clamp.

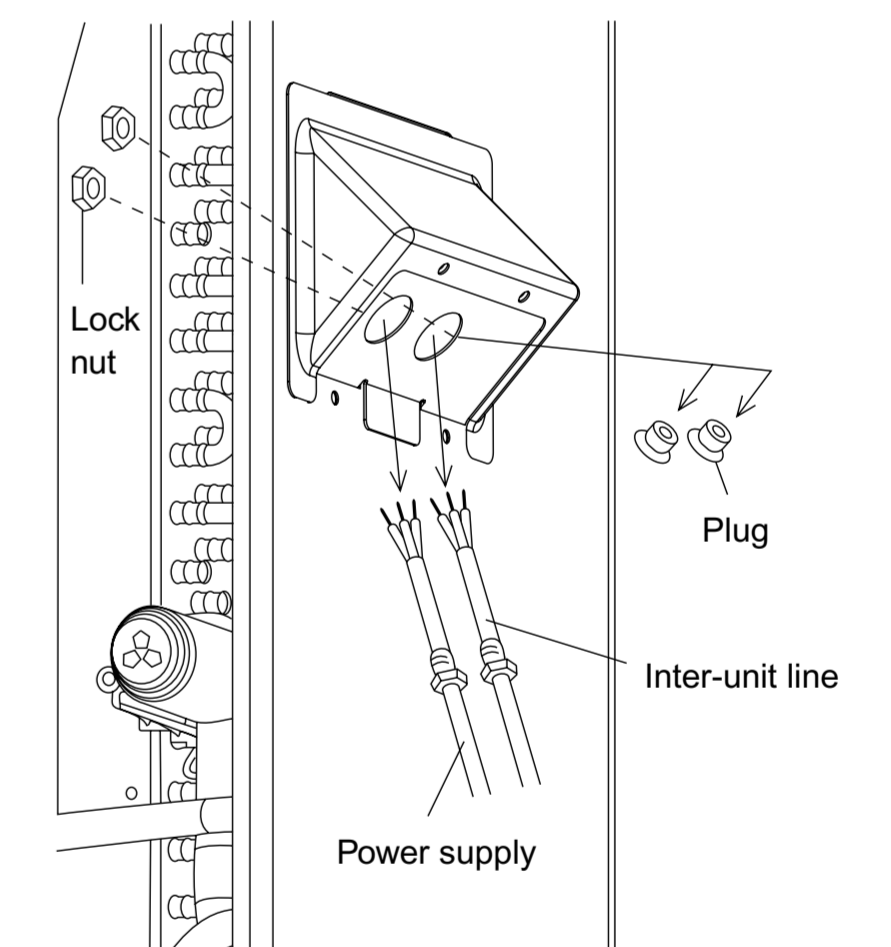

5

TEST RUN

1. Make a TEST RUN in accordance with the installation instruction sheet for the indoor unit.

2. OUTDOOR UNIT LEDS

When a malfunction occurs in the outdoor unit, the LED on the circuit board lights to indicate the error. Refer to the following table for the description of each error according to the LED.

LED	Error contents
1 flash	Communication error (Indoor unit – Outdoor unit)
2 flash	Discharge pipe temperature sensor
3 flash	Outdoor heat exchanger temperature sensor
4 flash	Outdoor temperature sensor
7 flash	Compressor temperature sensor
8 flash	Heat sink temperature sensor
9 flash	Pressure switch abnormal
12 flash	IPM error
13 flash	Compressor rotor position cannot detect
14 flash	Compressor cannot operate
15 flash	Outdoor fan abnormal (upper fan)
16 flash	Outdoor fan abnormal (lower fan)
lighting	No error

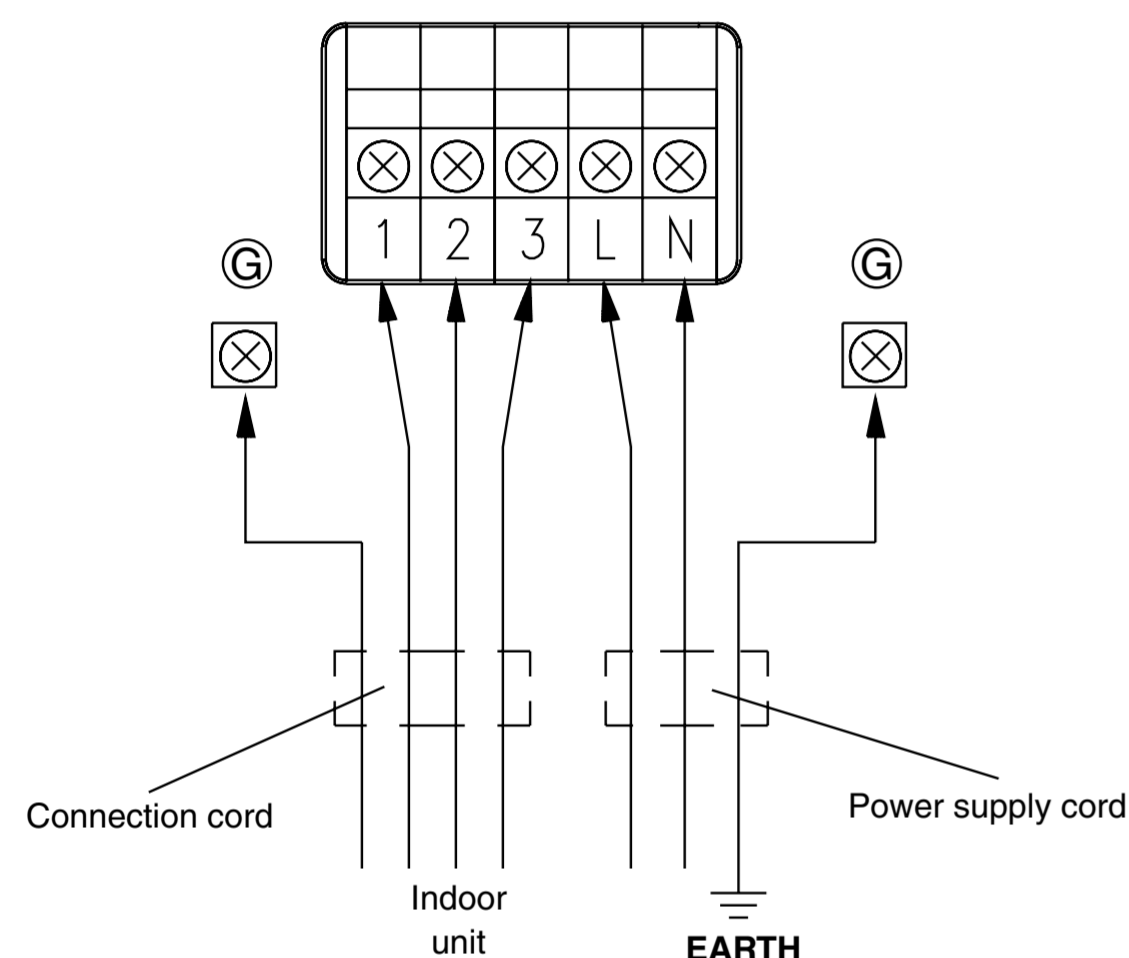
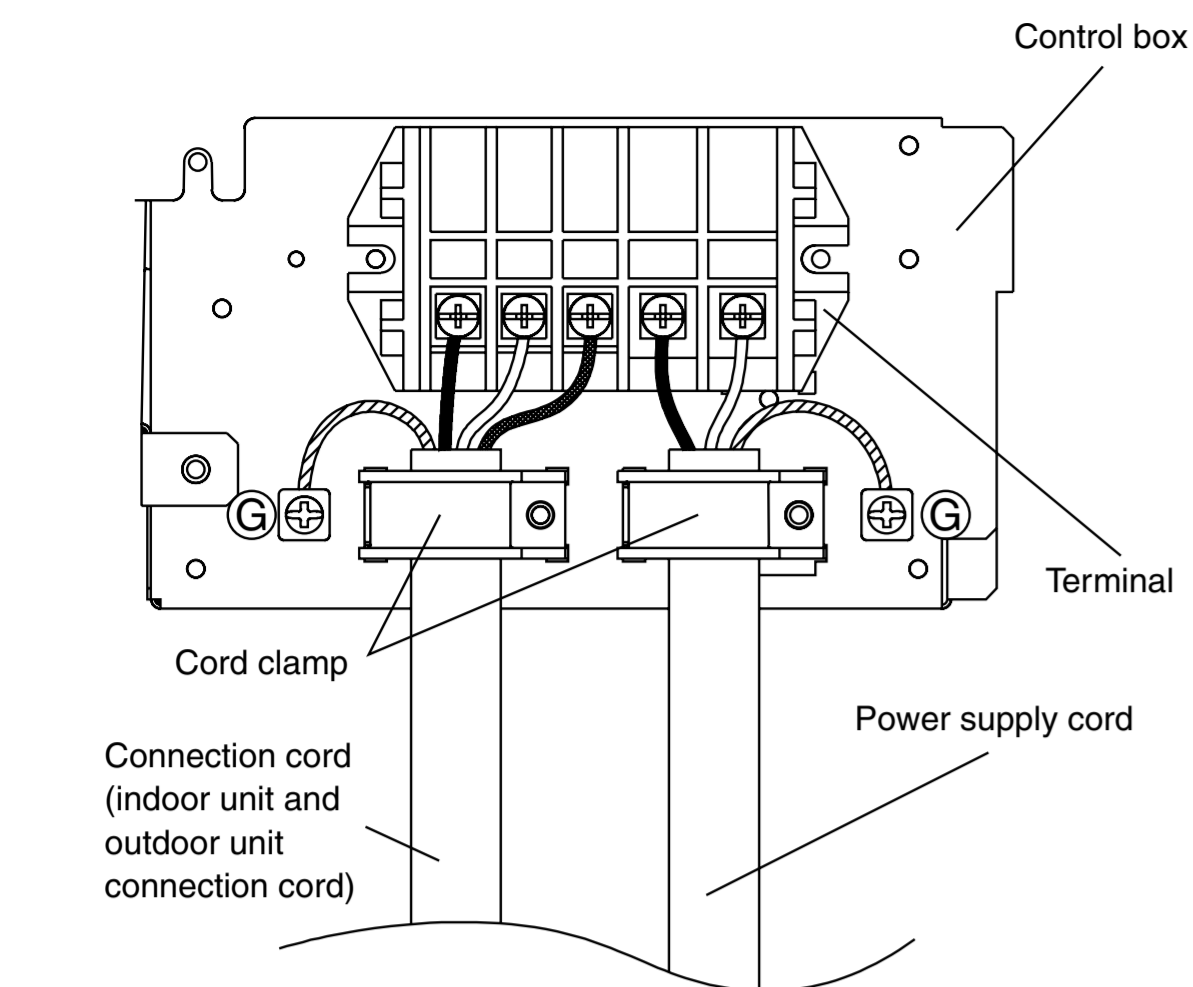

6

SPECIAL INSTALLATION SETTING

PUMP DOWN (Refrigerant collecting operation)

Perform the following procedures to collect the refrigerant when moving the indoor unit or the outdoor unit.

1. When the product is stopped:

①	Press the PUMP DOWN switch on the outdoor unit. (The LED on the outdoor unit circuit board lights.)
②	The pump down operation (cooling operation) begins right away. After operation starts, close the three-way valve (liquid).
③	After 2 – 3 minutes, operation stops. Close the three-way valve (gas) within one minute after operations stops.
④	The LED will go out three minutes after it stops. Disconnect the power supply after confirming that the LED has gone out.

2. When the product is operating:

①	Press the PUMP DOWN switch on the outdoor unit. The LED on the outdoor unit circuit board lights, and operation stops. At this point, recovery has not been completed, so do not close the two- and three-way valves.
②	The pump down operation (cooling operation) begins after three minutes. Close the three-way valve (liquid) after operation starts.
③	After 2 – 3 minutes, operation stops. Close the three-way valve (gas) within one minute after operations stops.
④	The LED will go out three minutes after it stops. Disconnect the power supply after confirming that the LED has gone out.

*When the pump down operation is repeated, temporarily disconnect the power supply after opening the closed valves (both liquid and gas). Reconnect the power supply after 2 - 3 minutes and perform the pump down operation.

*When the start of the operation after pump down operation has been completed, temporarily disconnect the power supply after opening the closed valves (both liquid and gas). Reconnect the power supply after 2 - 3 minutes and be sure to perform a test operation for cooling.

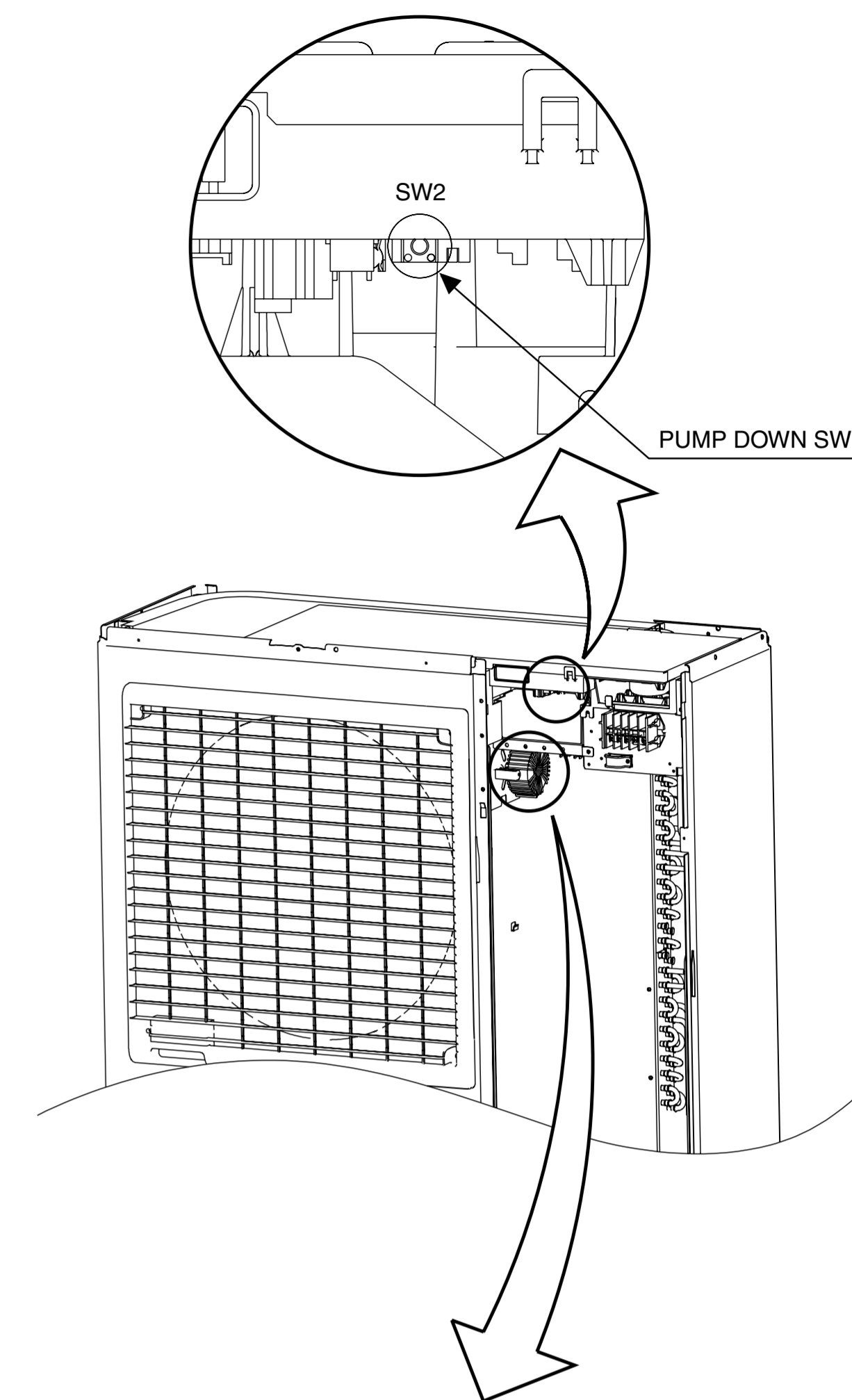
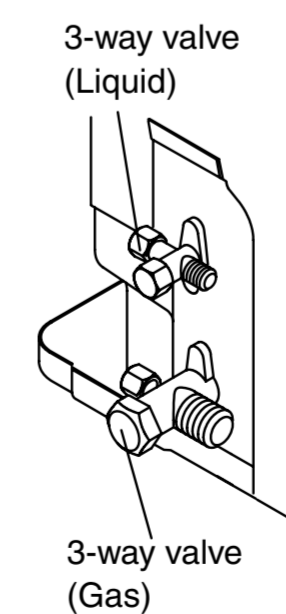

⚠ DANGER

This part (Choke coil) generates high voltages. Never touch this part.