

SAVE FOR CONSUMER INSTALLATION INSTRUCTIONS

- ① POSITION SINK UPSIDE DOWN ON COUNTER TOP

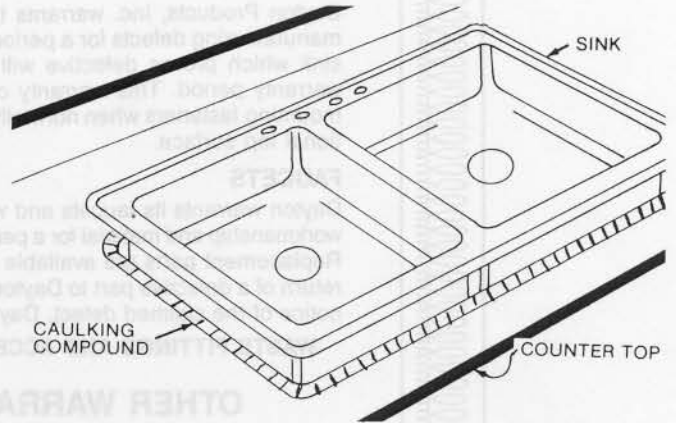

- ②

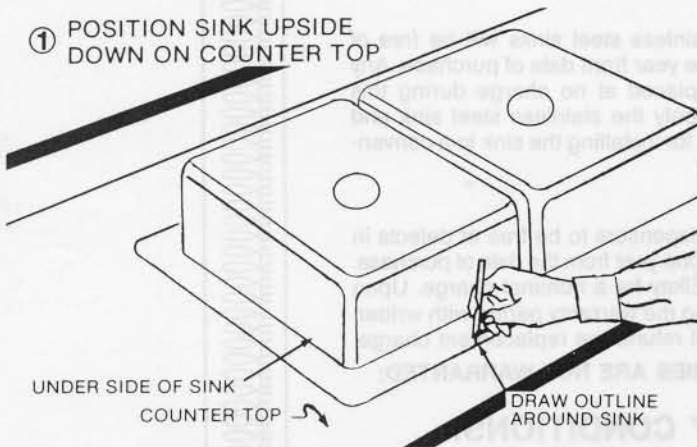
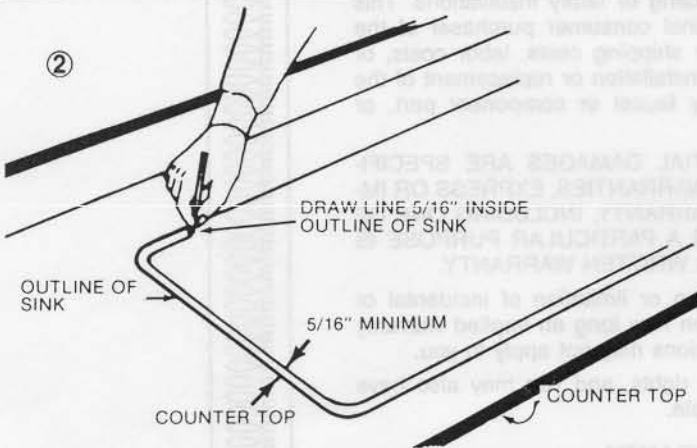

- ⑤ Mount faucets in place on sink and tighten.

- ⑥ Set sink in cutout.

- ⑦ Preassemble clamps, screws and plastic pads.

- ⑧ From underside — place clamp in center along each side hand tighten to hold sink in place. Fasten balance of clamps along edges spaced usually 3 on each end, balance equally along front and back.

- ⑨ From the top — check seal between sink edge and counter top. Adjust clamps if necessary.

- ⑩ Lightly tighten clamps evenly with screw driver or socket wrench in rotation until sink is perfectly sealed.

- ③ Cut on inside line. Cut straight up and down, you will have a better installation.

- ④ Apply caulking compound around cutout on counter

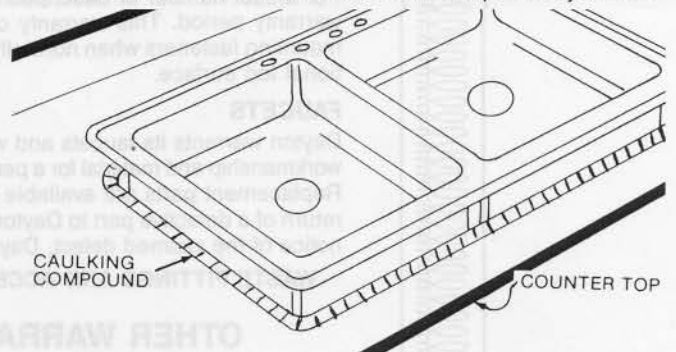
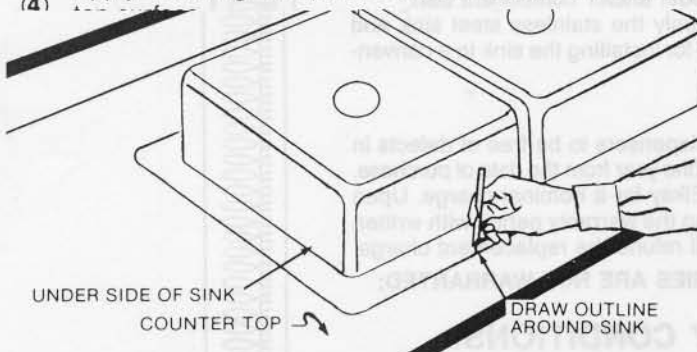

- ②

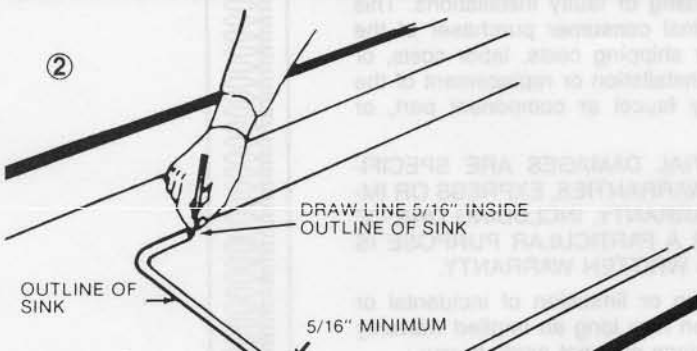

- ⑤ Mount faucets in place on sink and tighten.

- ⑥ Set sink in cutout.

- ⑦ Preassemble clamps, screws and plastic pads.

- ⑧ From underside — place clamp in center along each

IMPORTANT CONSUMER INFORMATION

DAYTON LIMITED WARRANTY

SINKS

Dayton Products, Inc. warrants that stainless steel sinks will be free of manufacturing defects for a period of one year from date of purchase. Any sink which proves defective will be replaced at no charge during this warranty period. This warranty covers only the stainless steel sink and mounting fasteners when normally used for installing the sink to a conventional top surface.

FAUCETS

Dayton warrants its faucets and water dispensers to be free of defects in workmanship and material for a period of one year from the date of purchase. Replacement parts are available from Elkay for a nominal charge. Upon return of a defective part to Dayton during the warranty period with written notice of the claimed defect, Dayton will refund the replacement charge.

WASTE FITTINGS AND ACCESSORIES ARE NOT WARRANTED;

OTHER WARRANTY CONDITIONS:

Our warranty does not cover product failure caused by abusive treatment, misuse, or damage due to handling or faulty installations. This warranty is extended only to the original consumer purchaser of the product. This warranty does not cover shipping costs, labor costs, or any other damages for such items as installation or replacement of the sink, diagnosis or replacement of any faucet or component part, or any other expense or loss.

ALL INCIDENTAL OR CONSEQUENTIAL DAMAGES ARE SPECIFICALLY EXCLUDED. NO ADDITIONAL WARRANTIES, EXPRESS OR IMPLIED, ARE GIVEN. ANY IMPLIED WARRANTY, INCLUDING ONE OF MERCHANTABILITY OR FITNESS FOR A PARTICULAR PURPOSE IS LIMITED TO THE DURATION OF THIS WRITTEN WARRANTY.

Some states do not allow the exclusion or limitation of incidental or consequential damages or limitations on how long an implied warranty lasts, so the above limitations or exclusions may not apply to you.

This warranty gives you specific legal rights, and you may also have other rights which vary from state to state.

TO OBTAIN SERVICE UNDER WARRANTY

1. Write to Dayton Products, Inc. Attention: Consumer Services,
2222 Camden Court
Oak Brook, Illinois 60521

Dayton Products, Inc. warrants that stainless steel sinks will be free of manufacturing defects for a period of one year from date of purchase. Any sink which proves defective will be replaced at no charge during this warranty period. This warranty covers only the stainless steel sink and mounting fasteners when normally used for installing the sink to a conventional top surface.

FAUCETS

Dayton warrants its faucets and water dispensers to be free of defects in workmanship and material for a period of one year from the date of purchase. Replacement parts are available from Elkay for a nominal charge. Upon return of a defective part to Dayton during the warranty period with written notice of the claimed defect, Dayton will refund the replacement charge.

WASTE FITTINGS AND ACCESSORIES ARE NOT WARRANTED;

OTHER WARRANTY CONDITIONS:

Our warranty does not cover product failure caused by abusive treatment, misuse, or damage due to handling or faulty installations. This warranty is extended only to the original consumer purchaser of the product. This warranty does not cover shipping costs, labor costs, or any other damages for such items as installation or replacement of the sink, diagnosis or replacement of any faucet or component part, or any other expense or loss.

ALL INCIDENTAL OR CONSEQUENTIAL DAMAGES ARE SPECIFICALLY EXCLUDED. NO ADDITIONAL WARRANTIES, EXPRESS OR IMPLIED, ARE GIVEN. ANY IMPLIED WARRANTY, INCLUDING ONE OF MERCHANTABILITY OR FITNESS FOR A PARTICULAR PURPOSE IS LIMITED TO THE DURATION OF THIS WRITTEN WARRANTY.

Some states do not allow the exclusion or limitation of incidental or consequential damages or limitations on how long an implied warranty lasts, so the above limitations or exclusions may not apply to you.