

DAYTON[®] SPECIFICATIONS

Dayton[®] Premium Double Bowl Sink Model DPA23322

GENERAL

Sink is formed of #20 (1mm) gauge, 300 series nickel-bearing stainless steel. Top mount.

DESIGN FEATURES

Bowl Depth: 8" (203mm)

Rim Height: 3/8" (9.5mm)

Coved Corners: 3" (76mm) vertical and 2-1/4" (57mm) horizontal radius

Finish: Exposed surfaces are polished to a Premium Highlighted Satin finish.

Underside: Fully undercoated to dampen sound and reduce condensation.

OTHER

Drain Opening: 3-1/2" (89mm)

OPTIONAL ACCESSORIES

Bottom Grid: GOBG1415SS

Drain: D1125

Cutting Board: CB1516

Rinsing Basket: LKWRB1316SS, LKWERBSS

Utensil Caddy: LKWUCSS

Sink complies with ASME A112.19.3/ CSA B45.4



Sinks are listed by IAPMO[®] as meeting the applicable requirements of the Uniform Plumbing Code[®], International Plumbing Code[®], and National Plumbing Code of Canada.

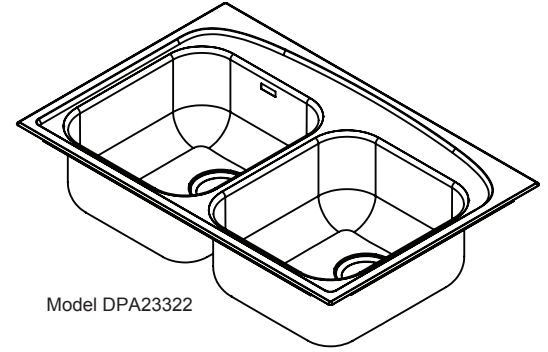

Model DPA23322



SINK DIMENSIONS (INCHES)*

Model Number	Overall		Inside Each Bowl			Cutout in Countertop (1-1/2" (38mm) Radius Corners)		No. of 1-1/2" (38mm) Dia. Faucet Holes	Minimum Cabinet Size
	L	W	L	W	D	L	W		
DPA23322	33 (838mm)	22 (559mm)	14 (356mm)	15-3/4 (400mm)	8 (203mm)	32-3/8 (822mm)	21-3/8 (543mm)	1, 2, MR2 3, 4 or 5	36 (914mm)

*Length is left to right. Width is front to back.

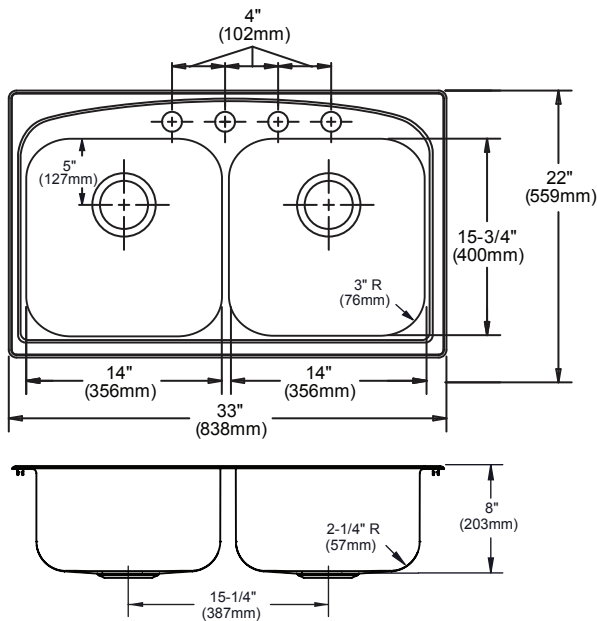

Hole Drilling Configurations

1-1/2" (38mm) Diameter Faucet Holes on 4" (102mm) Centers

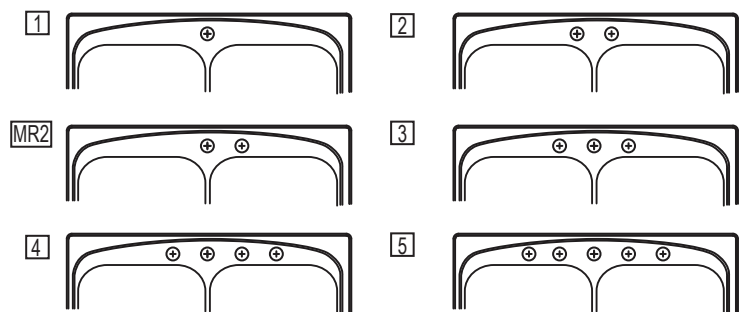

U-Channel Type Mounting System

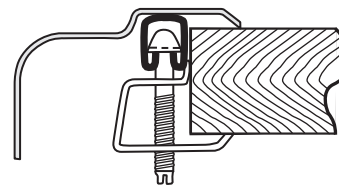

In keeping with our policy of continuing product improvement, Elkay reserves the right to change product specifications without notice. Please visit elkay.com for most current version of Elkay product specification sheets.

This specification describes an Elkay product with design, quality and functional benefits to the user. When making a comparison of other producers' offerings, be certain these features are not overlooked.