

Combi-Steam Oven

DGC 4084 XL

DGC 4086 XL



Combi-Steam Oven DGC 4084 XL / DGC 4086 XL



Classic DGC 4084 XL



Europa DGC 4086 XL

FEATURES

Cooking Modes:

- 100% Convection Oven
- 100% Steam Oven
- 100% Combination Steam Oven

Moisture combined with Convection Plus, Surround and Broil

XL PerfectClean cavity

Lift-up Control Panel conceals water and condensate container

Over 100 MasterChef programs

5 MasterChef Gourmet programs

20 Favorites

CleanGlass door

INCLUDED ACCESSORIES

- 1 Universal tray
- 1 PerfectClean wire rack
- 1 XL perforated stainless steel pan (DGGL 12)
- 1 half-sized XL perforated stainless steel pan (DGGL 20)
- 1 half-sized XL solid stainless steel pan (DGG 20)

STANDARD HANDLES

For Classic:
Signature
Handle
DS 4045



For Europa:
Square
Handle
DS 4043



OPTIONAL HANDLES

Profi Handle
DS 4040



Classic Handle
DS 4041



Straight Handle
DS 4044



DS 4045

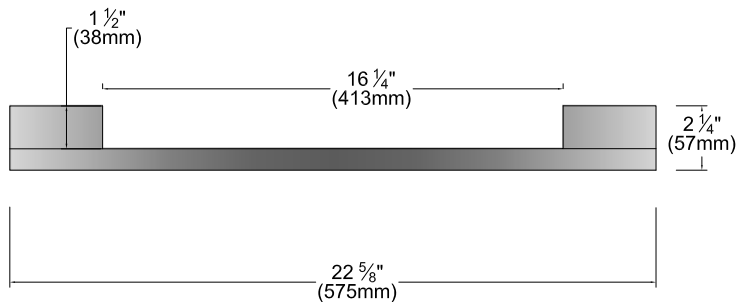

DS 4043

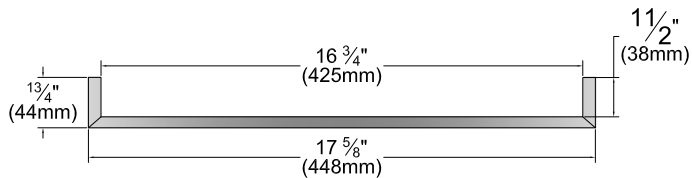

Combi-Steam Oven

DGC 4084 XL / DGC 4086 XL



SPECIFICATIONS

DGC 4084 XL (Classic) – Item 23408432USA

DGC 4086 XL (Europa) – Item 23408632USA

Overall Width – excluding fascia	21 ⁵ / ₈ " (549mm)
Overall Height	17 ⁹ / ₁₆ " (446mm)
Overall Depth	21 ¹ / ₂ " (547mm)
Depth with Door Open	34 ³ / ₄ " (883mm)
Overall Fascia Dimensions	23 ⁷ / ₁₆ " (595mm) W x 18" (455.5mm) H x 7 ⁷ / ₈ " (22/23mm) Thick
Oven Interior Dimensions	16" (406mm) W x 9 ¹ / ₈ " (232mm) H x 16 ⁷ / ₃₂ " (412mm) D
Built-In	
Minimum Cabinet Width	22 ¹ / ₁₆ – 22 ³ / ₈ " (560 – 568mm)
Minimum Cabinet Height	17 ⁵ / ₈ " (448mm)
Minimum Cabinet Depth	>21 ⁷ / ₈ " (555mm)
Minimum Base Support	47 lbs
Additional Cut-outs Required	Yes 2 x 12" cut-out required for ventilation, 150 sq. cm
Electrical	
Electrical Requirements	240V, AC, 60Hz, 20 Amps
Power Cord	Pigtail hard wired 240V power cord 5' or 1.5m
Cut Out for Power Cord	Min. 3" square
Electrical Rating	3.4 kW (240V)
Total Amps	16 Amps on 240V
Shipping	
Shipping Weight	65 lbs
Shipping Dimensions	26 ⁷ / ₃₂ " W x 21 ⁵ / ₈ " H x 23 ¹ / ₁₆ " L
Support	
Call	800.843.7231
20/20	©2020technologies.com

TRIM KIT: Classic

EBA 5470 for 70cm width (Item #22996178USA)

EBA 5476 for 30" width (Item #22996179USA)

TRIM KIT: Europa

EBA 5570 for 70cm width (Item #22996191USA)

EBA 5576 for 30" width (Item #22996192USA)

All installations must be done in accordance with local codes.

Combi-Steam Oven DGC 4084 XL / DGC 4086 XL



PRODUCT VIEWS

Isometric View

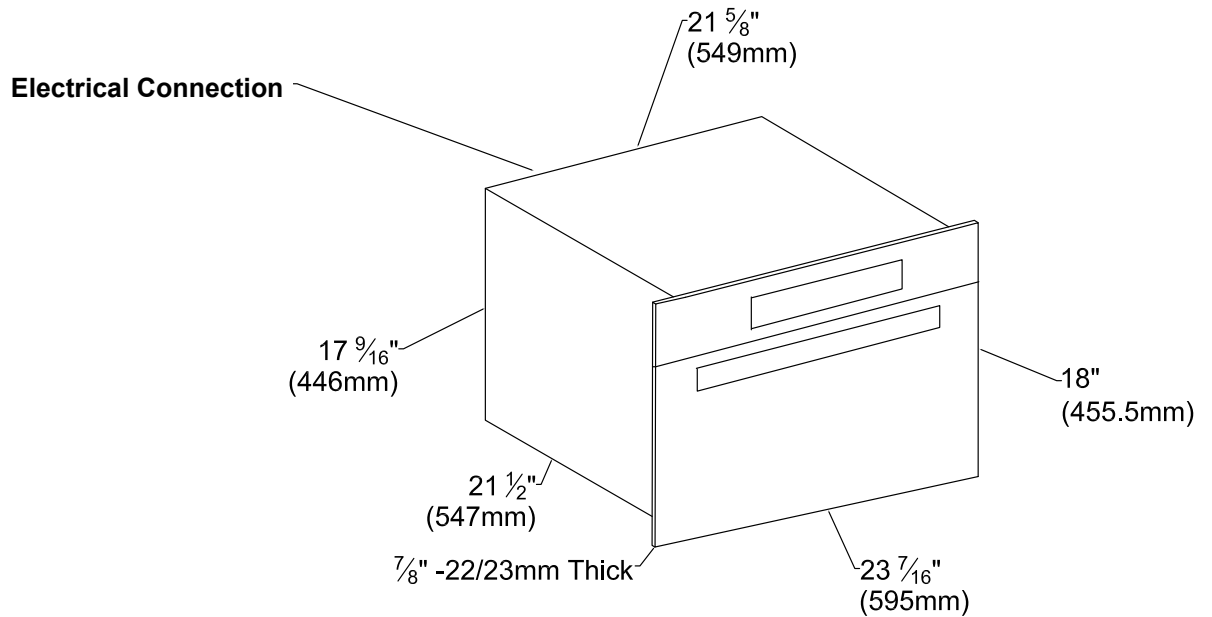

Front View

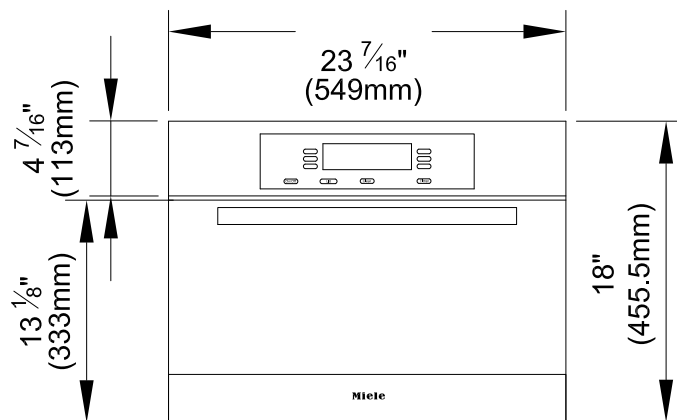

PRODUCT VIEWS

Top View

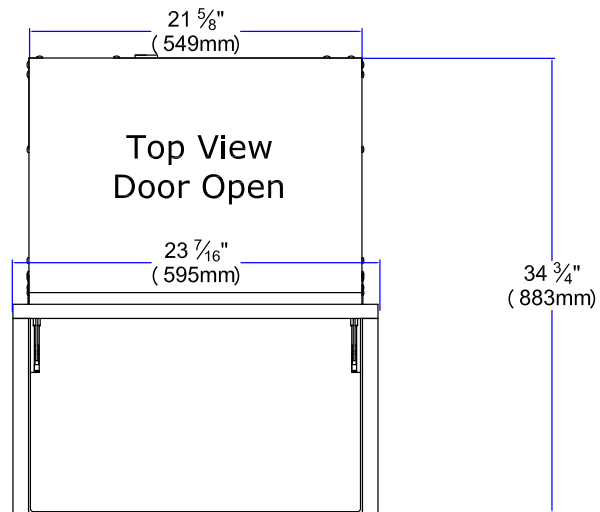

Side View with Door Open

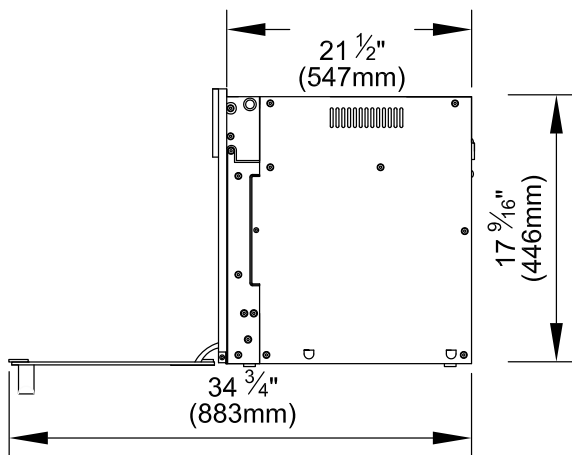

Side View with Lift Panel Up

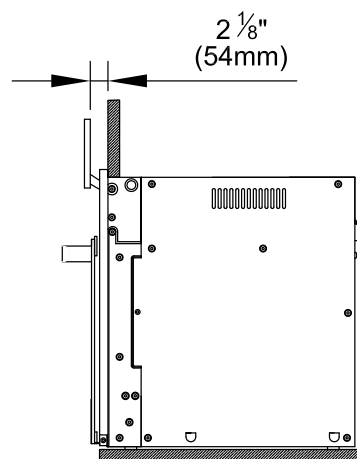

INSTALLATION SPECIFICATIONS

Wall Cabinet Installation

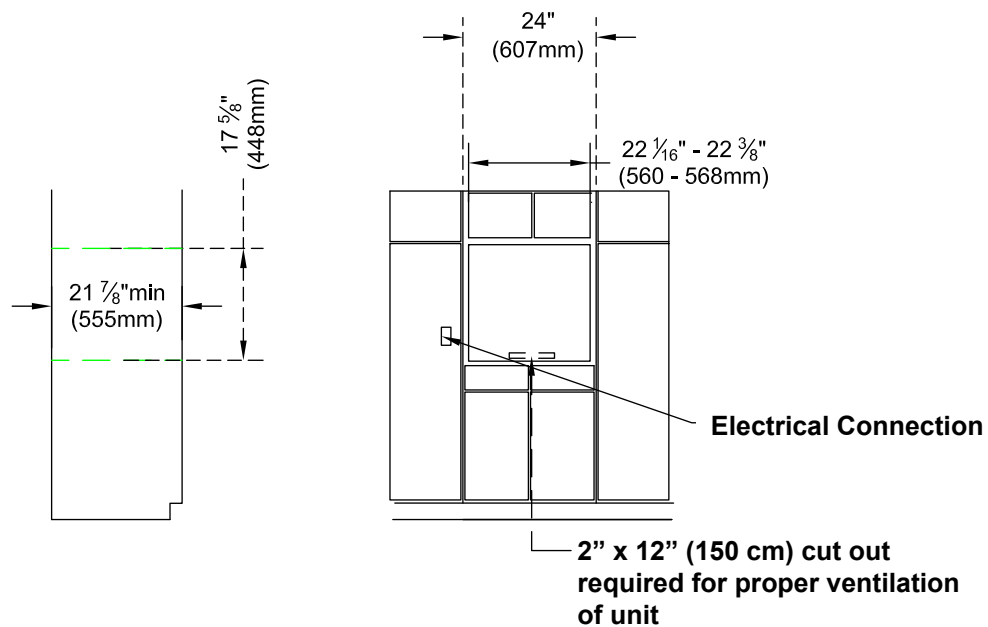

Wall Mount Stacked Installation

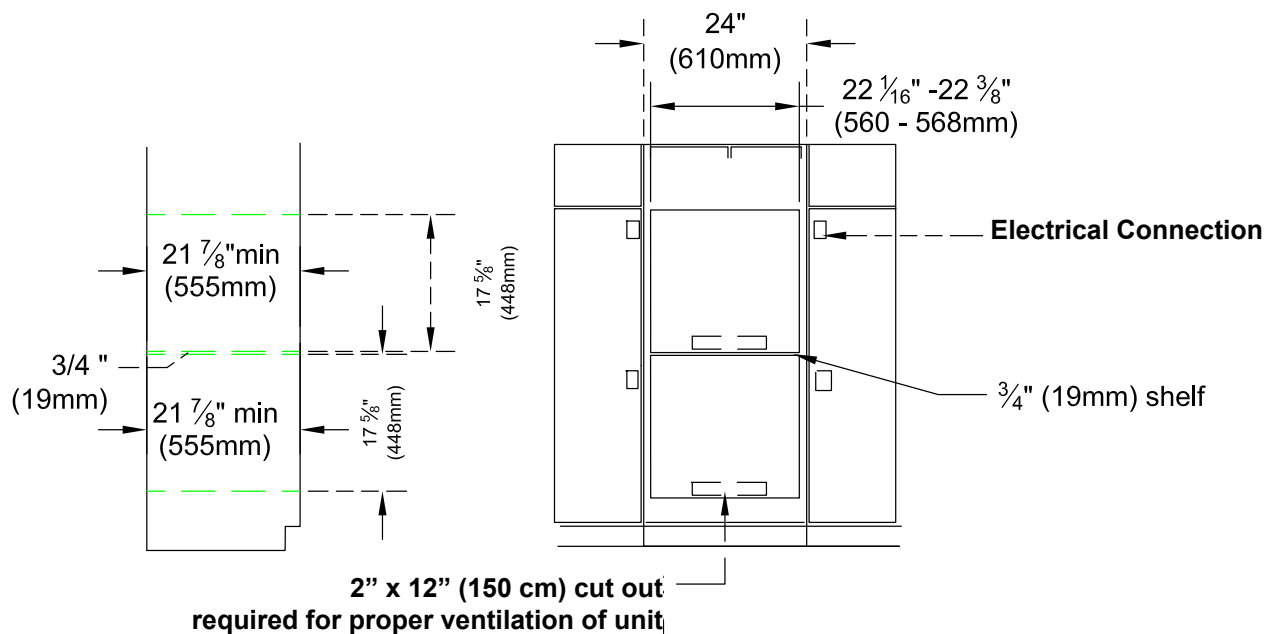

INSTALLATION SPECIFICATIONS

Undercounter Installation

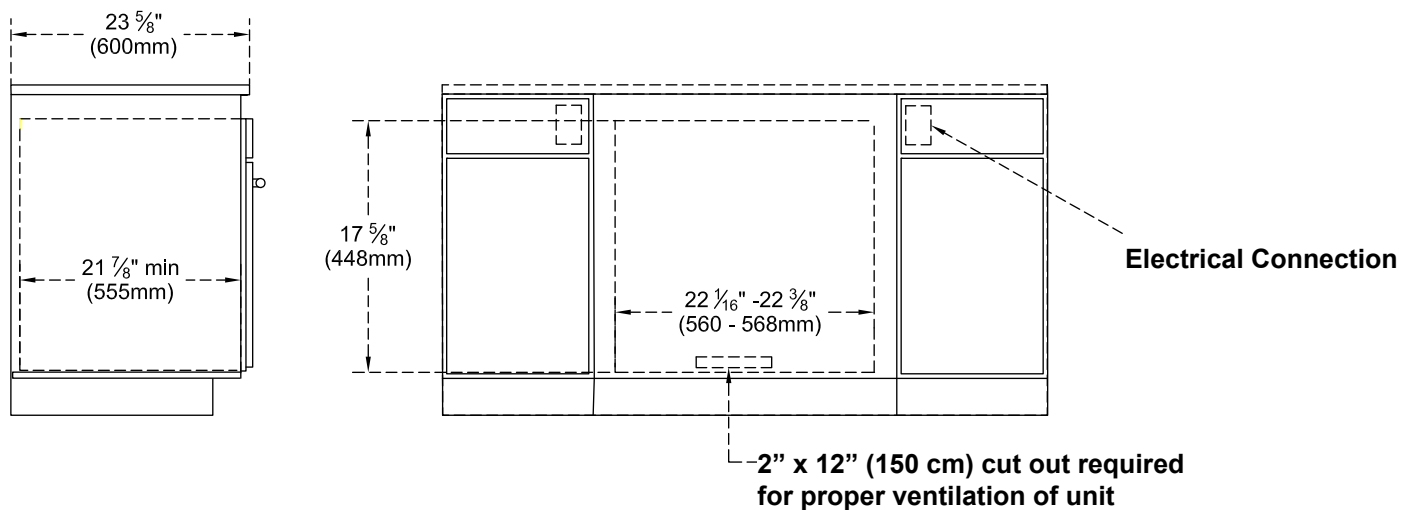

Undercounter Side-by-Side Installation

