

Double DishDrawer™ Dishwasher, Tall, Sanitize

Series 9 | Professional

Stainless Steel



Part of our Professional series, with stainless steel styling and room for your larger dinner plates and dishes.

- Six wash programs, as well as additional Quick wash, Sanitize and Extra Dry options
- Flexible racking can be folded down to fit bigger dishes

DIMENSIONS

Height	34 - 36 3/8"
Width	23 9/16"
Depth	22 9/16"

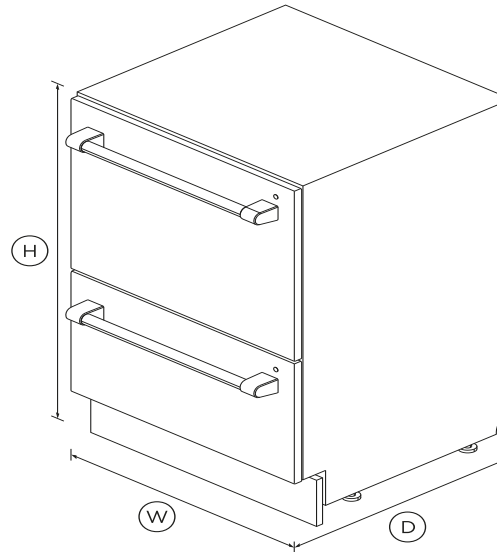

FEATURES & BENEFITS

Ease of use

DishDrawer™ Dishwashers are as easy to open and close as kitchen drawers and can be conveniently positioned at bench height for ease of loading and minimal bending. Flexible racking allows you to make adjustments to fit in a variety of dishes.

Independent wash

With the ability to use both drawers independently and select different wash programs the DishDrawer™ Dishwasher can wash everything from fine glass and crystal to heavily soiled pots and

pans.

True half load

Each drawer holds a true half load for guilt-free small washes and fast turnaround of your dishes. Both drawers operate independently so different wash cycles can operate simultaneously to accommodate a variety of loads.

Complementary design

DishDrawer™ Dishwashers are designed to match the Fisher & Paykel family of kitchen appliances, with matching handles, premium styling and quality materials for a stylish finish in your kitchen.

Quick, Sanitize and Extra Dry options

The Quick Wash modifier delivers a faster wash while maintaining performance. The Sanitize option provides extra protection killing 99.9% of bacteria in the final rinse. The Extra Dry setting is perfect for plastic dishes.

Quiet performer

Running at a very low decibel rating, these DishDrawer™ dishwashers do their job without making a fuss. The combination of intelligent technology and simple mechanics means greater reliability and excellent wash performance.

SPECIFICATIONS

Accessories

Cutlery basket	•
Kickstrip	included
Knife clip and multipurpose	•
Professional round flush handle	AHP3-DWDD-SX
Professional round handle kit	AHP2-DWDD-SX
Professional square handle kit	AHV2-DD24

Capacity and loading

Accommodates round plates	12.25" (top) 11" (bottom)
Adjustable height, foldable	•
Fold down tines	•
Pitch adjustable tines	•
Place settings	14

Consumption

Energy rating	Energy star
Energy usage	263 kWh/year

Controls

Child lock	•
Electronic fault/Diagnostic	•
End of cycle beeps	•
Energy saving delay start	•
Internal wash selector	•
One button start	•
Rinse aid indicator light	•

Features

Fan assisted drying	•
Flow through detergent	•
Quiet operation	•
SmartDrive™ technology	•

Performance

Noise on gentle cycle top	44dBA
---------------------------	--------------

Power requirements

Amperage	9.6A
----------	-------------

Electric circuit	3 wire
Rated current	15A
Supply frequency	60Hz
Supply voltage	120V

Product dimensions

Depth	22 9/16"
Height	34 - 36 3/8"
Width	23 9/16"

Warranty

Parts and labor	Limited 2 years
-----------------	------------------------

Wash Programs

Delicate	•
Eco	•
Extra Dry	•
Fast	•
Heavy	•
Medium	•
Normal eco	•
Number of wash programs	6
Quick	•
Rinse	•
Sanitize	•
Wash modifiers	3

Water connection

Inlet water temperature	Max 140°F
-------------------------	------------------

Supplied hose to suit 3/8" •

SKU 82756

The product dimensions and specifications in this page apply to the specific product and model. Under our policy of continuous improvement, these dimensions and specifications may change at any time. You should therefore check with Fisher & Paykel's Customer Care Centre to ensure this page correctly describes the model currently available. ? Fisher & Paykel Appliances Ltd 2020

Other product downloads available at fisherpaykel.com

 [Quick Start Guide](#)

 [User Guide](#)

 [Installation Guide](#)



A PEACE OF MIND SALE

24 Hours 7 Days a Week Customer Support

T 1.888.936.7872 [Wwww.fisherpaykel.com](http://www.fisherpaykel.com)