

# Integrated Double DishDrawer™ Dishwasher, Tall, Sanitize

Series 9 | Integrated

Panel Ready



Doing the dishes got easier. Load one drawer while the other washes – with the top drawer fitting your large dinner plates easily.

- Knock to pause function is perfect if you miss a dish
- Six wash programs, as well as additional Quick wash, Sanitize and Extra Dry options
- Flexible racking can be folded down to fit bigger dishes

- Customize with your own kitchen cabinetry or purchase our stainless steel door panel accessory

## DIMENSIONS

<b>Height</b>	<b>34 - 36 3/8"</b>
<b>Width</b>	<b>23 9/16"</b>
<b>Depth</b>	<b>22 1/2"</b>

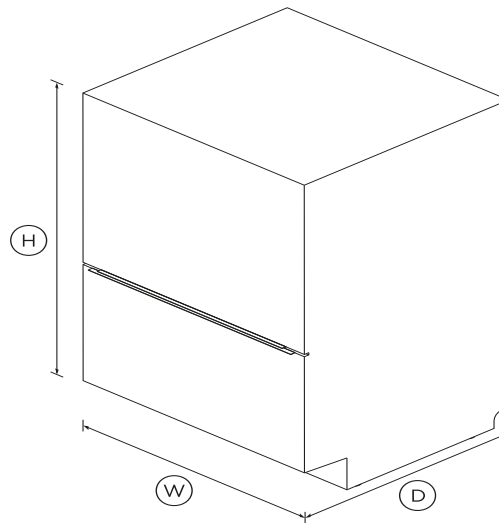

## FEATURES & BENEFITS

### Seamless integration

Slide your DishDrawer™ Dishwasher into an existing kitchen space or integrate into kitchen cabinetry, for a seamless look whilst delivering superior dish care.

### Ease of use

DishDrawer™ Dishwashers are as easy to open and close as

kitchen drawers and can be conveniently positioned at bench height for ease of loading and minimal bending. Flexible racking allows you to make adjustments to fit in a variety of dishes.

### Independent wash

With the ability to use both drawers independently and select different wash programs the DishDrawer™ Dishwasher can wash everything from fine glass and crystal to heavily soiled pots and pans.

### True half load

Each drawer holds a true half load for guilt-free small washes and fast turnaround of your dishes. Both drawers operate independently so different wash cycles can run simultaneously to accommodate a variety of loads.

### Quick, Sanitize and Extra Dry options

The Quick wash modifier delivers a faster wash while maintaining performance. The Sanitize option provides extra protection killing 99.9% of bacteria in the final rinse. The Extra Dry setting is perfect for plastic dishes.

### Knock to pause

Instead of needing a remote control, these DishDrawer™ Dishwashers have a knock to pause function. A knock on the front panel will pause the dishwasher which can be re-started again by using the start/play button.

### Quiet performer

Running at a very low decibel rating, these DishDrawer™ Dishwashers do their job without making a fuss. The combination of intelligent technology and simple mechanics means greater reliability and excellent wash performance.

## SPECIFICATIONS

### Accessories

Contemporary round handle	<b>Part number 81671</b>
Contemporary square fine	<b>Part number 82104</b>
Contemporary square handle	<b>Part number 81908</b>

Cutlery basket	•
Kickstrip	<b>Recessed</b>
Knife clip and multipurpose	•
Optional handle	<b>513545 D3 front mount fitting</b>
Optional stainless steel door kit	<b>81261 ADDD24DT</b>
Professional round flush handle	<b>Part number 82140</b>
Professional round handle kit	<b>Part number 82142</b>
Professional square handle kit	<b>Part number 81727</b>

**Capacity and loading**

Accommodates round plates	<b>12.25" (top) 11" (bottom)</b>
Adjustable height, foldable	•
Fold down tines	•
Pitch adjustable tines	•
Place settings	<b>14</b>

**Consumption**

Energy rating	<b>Energy star</b>
Energy usage	<b>263 kWh/year</b>

**Controls**

Child lock	•
Electronic fault/Diagnostic	•
End of cycle beeps	•
Energy saving delay start	•
Internal wash selector	•
Knock to pause	•
Rinse aid indicator light	•

**Features**

Fan assisted drying	•
Flow through detergent	•
Quiet operation	•
SmartDrive™ technology	•

**Performance**

Noise on gentle cycle top	<b>44dBA</b>
---------------------------	--------------

**Power requirements**

Amperage	<b>9.6A</b>
Electric circuit	<b>3 wire</b>
Rated current	<b>15A</b>
Supply frequency	<b>60Hz</b>
Supply voltage	<b>120V</b>

**Product dimensions**

Depth	<b>22 1/2"</b>
Height	<b>34 - 36 3/8"</b>
Width	<b>23 9/16"</b>

**Warranty**

Parts and labor	<b>Limited 2 years</b>
-----------------	------------------------

**Wash Programs**

Delicate	•
Eco	•
Extra Dry	•
Fast	•
Heavy	•
Medium	•

Number of wash programs	<b>6</b>
Quick	•
Rinse	•
Sanitize	•
Wash modifiers	<b>3</b>

**Water connection**

Inlet water temperature	<b>max 140°F</b>
Supplied hose to suit 3/8"	•

SKU 81217

The product dimensions and specifications in this page apply to the specific product and model. Under our policy of continuous improvement, these dimensions and specifications may change at any time. You should therefore check with Fisher & Paykel's Customer Care Centre to ensure this page correctly describes the model currently available. ? Fisher & Paykel Appliances Ltd 2020

---

Other product downloads available at [fisherpaykel.com](http://fisherpaykel.com)



[Quick Start Guide](#)



[User Guide](#)



[Installation Guide](#)



[Data Sheet Integrated Double DishDrawer](#)



**A PEACE OF MIND SALE**

24 Hours 7 Days a Week Customer Support

T 1.888.936.7872 **W**[www.fisherpaykel.com](http://www.fisherpaykel.com)