

CROSSOVER 2.0

Coin/Card
Stack Washer & Dryer

In a class by itself.

Strength, durability, and performance are at the center of the newly refined Crossover 2.0 by Wascomat small chassis front load stacked washer & dryer combo. Built with professional grade components and loaded with powerful features, Crossover combines innovative technology, energy efficiency, and proven Wascomat reliability for optimal results every time.

Crossover 2.0 Key Features

- Extra large load drum — 22+ pound capacity
- 15,000+ cycle machine life design (tested at full load)
- Real-time clock for happy hour, promotional pricing
- Superb clean-ability with 4 field adjustable wash programs
- Top quality SKF bearings in a heavy duty cast iron housing
- 3 seals with 5 lips protect bearings
- 300 G-force for greatest spin moisture reduction and faster dry time
- Superior over-suds and unbalance tolerance
- AC motor (no brushes)
- Front access for easy serviceability
- Professional 8-point suspension and Pump drain standard
- Solid steel counterweights — no concrete
- Axial airflow ensures the shortest drying time
- Saves up to 60% on water vs. top load washers
- 2 cycle upgrade buttons enhance revenue
- Space-saving and Soft-mount design for easy installation
- ENERGY STAR® Certified
- Roller supported tumbler
- Easy to clean, heavy duty lint screen



Available in Gas or Electric.

Model No. (Gas) – Metered (Coin) / Card-ready:
WDHLP817G / WDHLP817GDC

Model No. (Electric) – Metered (Coin) / Card-ready:
WDHLP817E / WDHLP817EDC

Crossover 2.0 Washer Specifications at a Glance

Wash Capacity	22 lb / 10 kg
Cylinder Volume	3.5 cu ft / 98 liters
A. Overall Height	43 1/4 in (1098 mm)
B. Height to Center of Door	23 in (584 mm)
C. Height to Bottom of Door	12 3/16 in (310 mm)
D. Overall Width	27 in (686 mm)
E. Overall Depth	30 1/8 in (765 mm)
F. Depth w/ Door Open 90°	51 3/16 in (1300 mm)

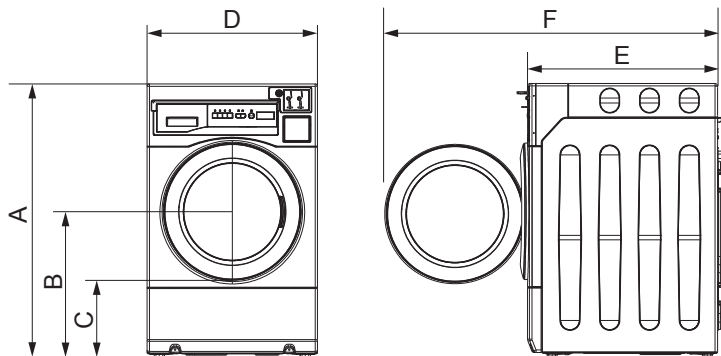

Preliminary specifications. Specifications subject to change without notice.

Crossover 2.0 Stack Washer & Dryer Preliminary Specifications

Model No. Gas	Metered (Coin) / Card-ready – Pump Model WDHLPS817G / WDHLPS817GDC
Model No. Electric	Metered (Coin) / Card-ready – Pump Model WDHLPS817E / WDHLPS817EDC
Motor	Variable-speed, reversible, thermoprotected, high-efficiency, controlled induction
Electrical Rating (Gas Model)	120 V/60 Hz / 1-phase
Electrical Rating (Electric Model)	208 or 240V (heating)/120V (motor and controls) / 60hz / 1-phase
Breaker Fuse Requirements (Gas Heat)	15A
Breaker Fuse Requirements (Electric Heat)	30A
Washer Cylinder Volume	3.5 cu ft (98 liters)
Dryer Cylinder Volume	7.0 cu ft (200 liters)
Washer Cylinder Diameter	21 5/8 in (550 mm)
Dryer Cylinder Diameter	26 in (660 mm)
Washer Cylinder Depth	18 1/4 in (464 mm)
Dryer Cylinder Depth	22 in (559 mm)
Wash/Dry Capacity	22 lbs (10 kg)
Airflow	170 cfm
Gas Heating	18,000 BTU/hr
Electric Heating	5.0 kW
Gas Connection	3/8 in MNPT
Wash Speed	45 RPM
Tumbling Speed	50 rpm
Exhaust Connection	4 in diameter
Approx. Net Weight	Dryer - 158 lbs (71.7 kg) Washer - 299 lbs (136 kg)

Crossover 2.0 Washer Dimensions

A. Overall Height	87 in (2210 mm)
B. Height to Center of Door	23 in (584 mm)
C. Height to Bottom of Door	12 3/16 in (310 mm)
D. Overall Width	27 in (686 mm)
E. Overall Depth	30 1/8 in (765 mm)
F. Depth w/ Door Open 90°	51 3/16 in (1300 mm)

* **NOTE:** the correct measurement of extraction efficiency is G-force, not RPM. A higher RPM does not mean greater extraction, which depends on cylinder diameter.

Refer installation and servicing to qualified, licensed personnel. Always read Installation and Operating Manuals and consult local codes before installation. Protect machines with properly rated circuit breakers ONLY. Warranty void if not properly installed.

Preliminary specifications.

Specifications subject to change without notice. Laundrylux assumes no responsibility for errors or omissions in this information.

Money boxes and coin meters sold separately.



8-Point Suspension

The robust 8-point suspension features advanced technology to keep loads in balance, eliminate oversuds, and finish the cycle. Premium counterweights are constructed of solid steel providing additional strength and enhancing the longevity of the machine.

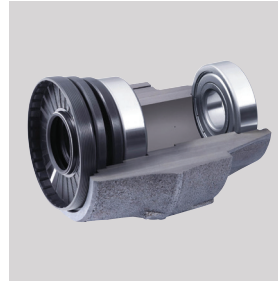

Heavy Duty SKF Bearings

Two commercial grade SKF bearings are sealed for maximum protection. Three individual seals with 5 lips provide a water-tight barrier around the drive shaft to protect the bearings from damaging moisture.



Time-of-Day Promo Pricing

Crossover 2.0 stack washers & dryers are easily programmable with promotional vend pricing at specified times and days. Multiple promotion events can be programmed at one time using the built-in real time clock.

Crossover 2.0 Washer Product Dimensions

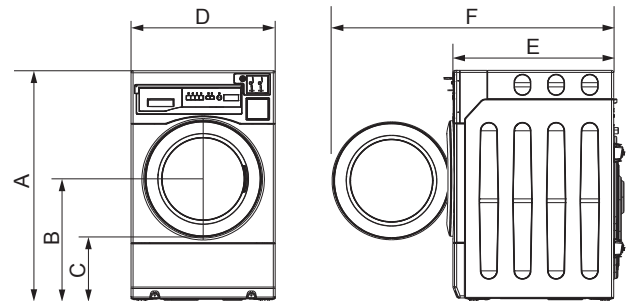

CROSSOVER 2.0

Laundrylux

800.645.2204 • laundrylux.com

Laundrylux • 461 Doughty Blvd., Inwood, NY 11096

Sales & Administration: 516-371-4400 • F 516-371-4204 • sales@laundrylux.com

Parts: 516-371-2000 • F 516-371-4029 • parts@laundrylux.com

Tech Support: 516-371-0700 • F 516-371-4029 • service@laundrylux.com