

# Miele

## Operating and Installation Instructions

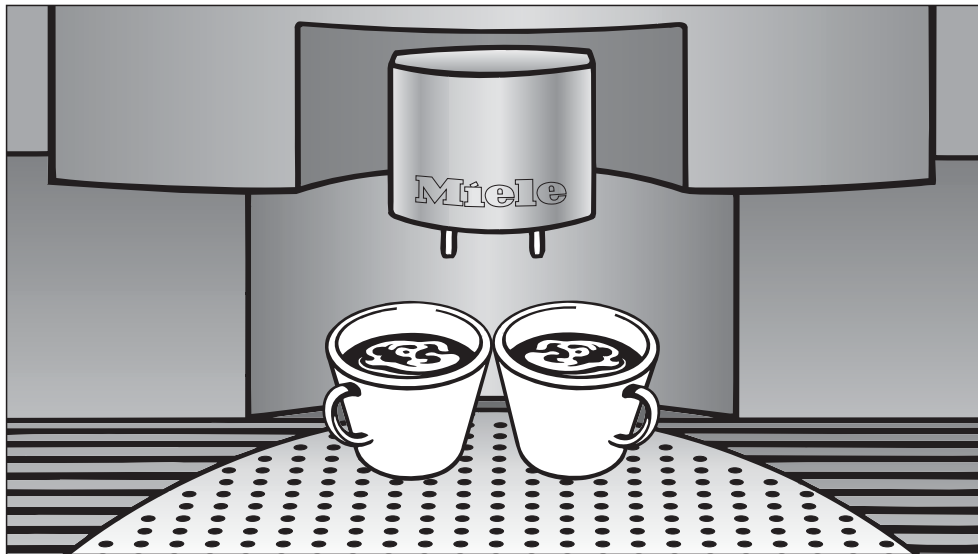

## Coffee System CVA 4070

To prevent accidents  
and machine damage  
read these instructions  
**before**  
installation or use.



M.-Nr. 06 911 520



## Contents

---

<b>IMPORTANT SAFETY INSTRUCTIONS</b> .....	5
<b>Guide to the machine</b> .....	8
<b>First steps to use</b> .....	10
<b>Filling water, beans or ground coffee</b> .....	11
Filling the water tank .....	11
Filling the beans container .....	12
Filling ground coffee .....	12
<b>Making coffee</b> .....	13
Turning on .....	13
Prewarming cups .....	14
Adjust the dispenser height .....	14
Espresso and coffee made from coffee beans .....	15
Espresso and coffee made from ground coffee .....	16
Cappuccino and milk froth .....	17
<b>Adjusting the coffee grinder</b> .....	19
<b>Settings</b> .....	20
Language .....	20
Clock .....	21
Timer .....	22
Grind amount .....	25
Pre-brewing .....	25
Temperature .....	26
Rinse automatic .....	26
Steam system .....	27
Lighting .....	27
Total no. coffees .....	28
System Lock .....	28
Water hardness .....	29
User profiles .....	30
Display .....	32
Tone options .....	32
Reset .....	33

## Contents

---

<b>Setting the serving sizes</b> .....	34
<b>Cleaning and Care</b> .....	35
<b>Descaling the appliance</b> .....	45
<b>Frequently asked questions</b> .....	47
<b>After sales service</b> .....	54
<b>Installation instructions</b> .....	55
<b>Caring for the environment</b> .....	56
<b>Electrical connection</b> .....	57
<b>Installation</b> .....	58
Adjusting the door hinges .....	60

# IMPORTANT SAFETY INSTRUCTIONS

**When using electrical appliances basic safety precautions should always be followed, including the following:**

**Read all instructions before installation or use of the coffee system.**

Please read these instructions carefully to prevent accidents and machine damage.

This appliance complies with current safety requirements. Improper use of the appliance can cause personal injury and material damage.

This appliance is for household use only, to prepare espresso, cappuccino and coffee. Do not use appliance other than for its intended use. Any other use could be dangerous.

The manufacturer cannot be held responsible for damage caused by improper use of the appliance.

## Electrical safety

■ Before connecting the appliance to the electrical supply make sure that the voltage and frequency listed on the data plate correspond with the household electrical supply. If in doubt, consult a qualified technician.

■ The appliance must be properly installed before operation to ensure that no electrical components are accessible. Ensure that power is not supplied to the appliance while installation work, repairs or maintenance is performed.

■ Be certain your appliance is properly installed and grounded by a qualified technician. To guarantee the electrical safety of this appliance, continuity must exist between the appliance and an effective grounding system. It is imperative that this basic safety requirement be met. If there is any doubt, have the electrical system of the house checked by a qualified electrician. The manufacturer cannot be held responsible for damages caused by the lack, or inadequacy, of an effective grounding system.

■ Do not use an extension cord to connect the appliance to electricity. Extension cords do not guarantee the required safety of the appliance (danger of overheating).

■ Before service or maintenance disconnect the power supply by either removing the fuse, "tripping" the circuit breaker or unplugging the unit.

■ Install or locate this appliance only in accordance with the provided installation instructions.

# IMPORTANT SAFETY INSTRUCTIONS

---

■ Installation work and repairs should only be performed by a trained technician in accordance with national and local safety regulations. Repairs and other work by unauthorized persons could be dangerous.

■ Never open the outer casing of the appliance. Tampering with electrical connections or components and mechanical parts is dangerous and may cause machine damage.

■ If the machine is installed in combination with other appliances, a protective base should be installed between the appliance and the unit.

■ Do not install or use outdoors even if installed in the display cabinet.

■ To protect against fire, electric shock and injury to persons do not submerge the cord or plugs in water or other liquids.

■ Do not let the cord hang over the edge of a table or counter, or touch hot surfaces.

■ Do not operate any appliance with a damaged cord or plug, or after the appliance malfunctions or has been damaged in any manner. Contact Miele.

■ Always attach the cord to the appliance first, then plug it into the wall outlet. To disconnect, turn the machine off, then remove the plug from the wall outlet.

## Use

The coffee system must be maintained daily to prevent the growth of harmful bacteria and mold. Please read the "Cleaning and care" section of this booklet. All parts are dishwasher safe except the brew unit and bean container.

**Caution!** Do not look directly or with an optical instrument into the lighting - laser radiation.

**Caution!** Risk of burns when dispensing hot beverages, they are extremely hot.

■ Persons which lack physical, sensory or mental abilities or experience with the machine should not use it without supervision or instruction by a responsible person.

■ Close supervision is necessary when any appliance is used by or near children.

■ Do not touch hot surfaces. Use handles or knobs.

■ Rinse the lines and the froth dispenser, and clean the unit before the first use.

■ To avoid injuries allow the coffee system to cool before cleaning or putting on and taking off parts. Turn the machine off at the main switch when not in use and before cleaning.

# IMPORTANT SAFETY INSTRUCTIONS

---

- Only fill the water tank with cold, fresh tap water. Warm or hot water, or any other liquids may damage the machine. The water should be changed daily to prevent bacteria or mold growth.
- Do not use mineral water. Mineral water leads to heavy calcium buildup in the machine that can damage the unit.
- Do not put anything but coffee beans into the beans container. Do not put ground coffee in the beans container, it will damage the grinding unit.
- Do not fill anything but ground coffee or a cleaning tablet (for the brew unit) in the funnel for ground coffee, otherwise it will get damaged.
- Sugar can damage the appliance! Caramelized or otherwise pre-treated coffee beans or other sugar containing beverages must not be put in the machine.
- Never place a cup with an alcohol-coffee mixture underneath the coffee dispenser. Plastic parts of the unit could catch fire!
- The hot water and steam dispensed could cause scalding. These functions must be used carefully. Never hold any parts of the body under the steam nozzle or the hot water dispenser. The machine must never be used to clean objects.
- Do not use the machine when the froth dispenser is removed. Danger of scalding with hot steam!
- Never use a steam cleaner to clean the appliance. Pressurized steam could damage electrical components and cause a short circuit.
- The appliance must be descaled regularly with the supplied descaling tablets. In areas with very hard water the machine may need to be descaled more often. The manufacturer cannot be held responsible for damages resulting from insufficient descaling.
- Only use the descaling tablets provided by Miele. Take care to use the correct mixture of water and descaler, otherwise it may cause damage.
- Depending on the fat content of the coffee, the brew unit may clog. Clean the brew unit every 200 cups with a cleaning tablet. The display shows a respective request.
- Dispose of the coffee waste in a trash can, not in the sink. The sink could get clogged.
- Do not hang, lean, sit or place heavy items on the door. The machine could be damaged.
- The use of accessory attachments not recommended by the appliance manufacturer may result in fire, electric shock or injury to persons.

## SAVE THESE INSTRUCTIONS

## Guide to the machine

---

### Front view

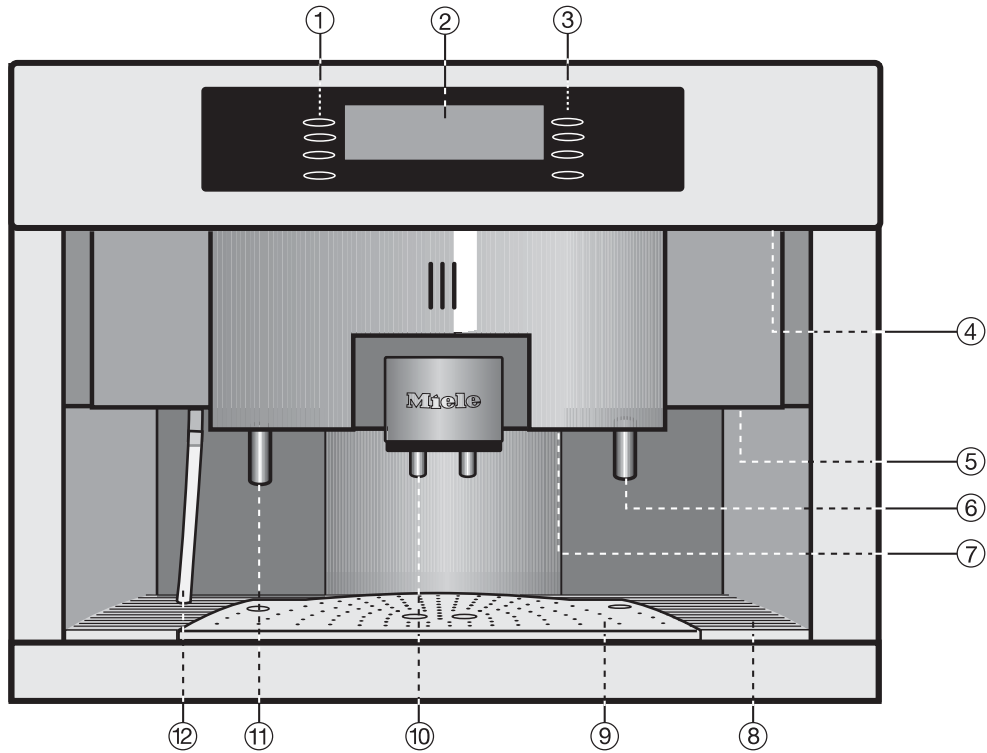

① Touch controls  
(lowest control "On/Off" button)

② Display

③ Touch controls  
(lowest control "Clear" button)

④ Top lighting

⑤ Door grip

⑥ Hot water spout

⑦ Bottom lighting

⑧ Plastic drip tray

⑨ Metal drip tray

⑩ Coffee dispenser  
(height adjustable)

⑪ Froth dispenser  
(removable for better cleaning)

⑫ Intake hose  
(removable together with dispenser)

## Guide to the machine

### Interior view

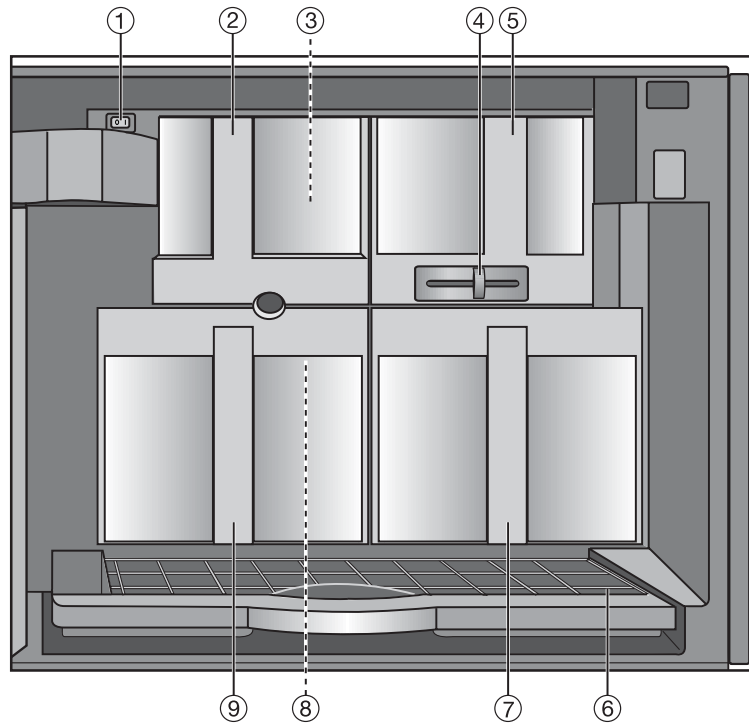

- ① Main switch
- ② Cover for ground coffee funnel
- ③ Funnel for ground coffee
- ④ Grind control lever
- ⑤ Coffee bean container
- ⑥ Drip tray with no-spill grid for transport
- ⑦ Water tank
- ⑧ Brew unit
- ⑨ Waste unit

## First steps to use

---

### Touch controls

Select a touch control with your fingertip to use the machine.

### Display

To select a menu, select the touch control next to the respective menu point.

If more features can be selected under one menu point, the menu has three dots (e.g. "Settings...").

**"more" / "back"**: If there are more menus which are not immediately shown, select "more" or "back" to see further options.

**"Clear"**: to go back to the previous screen.

**"Stop"**: to cancel coffee preparation.

**"OK"**: to save a setting.

### Before the first use

The appliance must be correctly installed and connected before the first use.

Clean the appliance and remove protective foils before the first use.



### Turning on

- Select "On/Off" to turn the coffee system on.

The display shows the clock. See "Settings - Clock - Setting the time of day" to set the time.

During the very first use, you will be prompted to select a language.

- Select the desired language touch control and then "OK".

The  symbol indicates the "Language" setting. If you accidentally select an unfamiliar language, simply look for the  symbol. Touch the control next to the flag symbol and select your language of choice.

- Customize the coffee system to your desired settings.

**Prepare two cups of coffee and dispose of them**, this will clean any coffee residues from the brew unit left from the quality control tests at the factory.

### Turning off

- Select "On/Off".

The display shows the time of day. After 60 seconds the display turns off (depending on the setting). See "Settings - Clock".

If the rinse automatic feature is turned on the machine will begin rinsing if a coffee was prepared that day.

## Filling water, beans or ground coffee

Before using the coffee system for the first time, clean the appliance. See "Cleaning and Care".

### Filling the water tank

The beans and the water quality is important for a good espresso or coffee. The water tank must be washed and filled with fresh cold drinking water before each day of use. The unit displays a reminder when turned on.

Never add hot water or any other liquids except cold water to the water tank.

Do not use mineral water. Mineral water leads to heavy calcium built-up in the machine that can damage the unit.

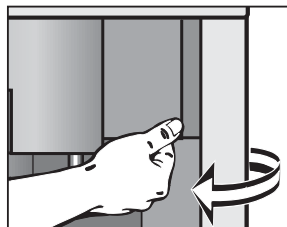

- Open the appliance door by grasping the recess next to the hot water spout and pulling the door towards you.

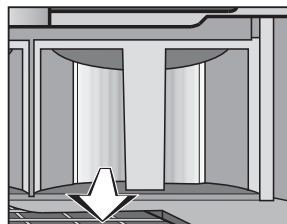

- Pull the water tank out.
- Fill the container with fresh, cold tap water to the "Max." mark.

A valve at the front of the tank prevents leaks.

- Close the lid and push the water tank into the unit until it clicks into place.

The water tank must be positioned correctly or the valve will leak. If the water tank has not clicked into place, pull the tank out, check and clean the niche.

## Filling water, beans or ground coffee

---

### Filling the beans container

Only fill espresso or coffee beans in the beans container. Anything else - including ground coffee - will damage the grinding unit. Caramelized or otherwise pre-treated beans or sugar containing beverages must not be filled into the appliance. It will damage the coffee system.

- Pull the bean container out.

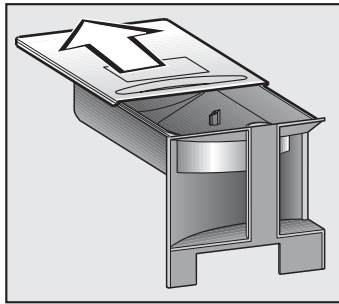

- Push the lid back and fill the container with roasted coffee beans.
- Push the lid back into place and put the beans container back into the appliance.
- Close the door.

### Filling ground coffee

A funnel for ground coffee is provided in case you would like to prepare a different coffee type, e.g. decaffeinated coffee.

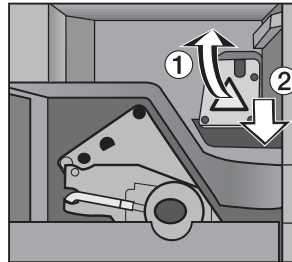

- Pull the cover for the ground coffee funnel out of the appliance and lift the funnel lid, ①.
- Place one spoonful of ground coffee into the funnel, ②, (using the supplied spoon) and close the lid.
- Push the cover into the appliance and close the door.

See "Making Coffee - Espresso and coffee made from ground coffee".

## Making coffee

The lines must be rinsed daily before the first use. This will happen automatically if "Rinse automatic" is set to "On" (see "Settings - Rinse Automatic") and the machine is cold. After heating, hot water runs out of the two spouts into the drip tray. If "Rinse automatic" was set to "Off", use "Care" to rinse the lines. See "Cleaning and Care - Rinse".

### Turning on

- Select the "On/Off" touch control.

A reminder to fill the water tank with fresh water is displayed.



Please fill and reinsert  
the water tank

Then the upper line in the display shows:

Preheating

< DESCALING  
< USER PROFILE: STANDARD  
< SETTINGS ▸ ...

If "Rinse automatic" is set to "On" (default), the machine rinses after the heating phase and the main menu is displayed.

## Making coffee

---

### Prewarming cups

All beverages should be made in a warm cup, to develop the aroma. The smaller the amount of coffee or espresso and the thicker the cups, the more important it is to prewarm the cups.

- Set the cup under the hot water spout.

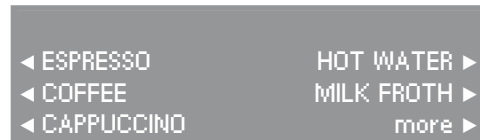

- Select "Hot water" from the main menu.
- Hot water is dispensed. Select "Stop" to stop the flow.
- Let the hot water sit for a moment to prewarm the cup, then empty the cup.

### Adjust the dispenser height

Depending on the cup height, the coffee dispensers can be adjusted so that the coffee and espresso have a shorter distance to the cup, do not cool and have a better crema.

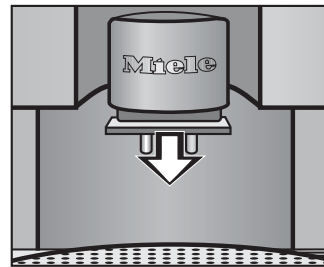

- Pull the coffee dispenser slowly up or down.

## Making coffee

### Espresso and coffee made from coffee beans

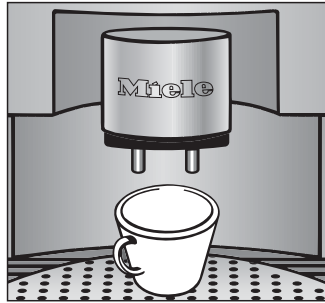

- Set a cup under the coffee dispenser.

The drink is dispensed through both dispensers at the same time.

- Select "Espresso" or "Coffee".

The machine grinds the beans and pre-brews the coffee (if "On" is selected under "Pre-brewing"). The selected beverage is dispensed.

Do not open the door during brewing. The machine will be damaged.

### Cancelling

- Select "Stop" to cancel the process.

The portion sizes for espresso, coffee and cappuccino can be set individually. See "Setting the serving sizes".

### Preparing two cups at the same time

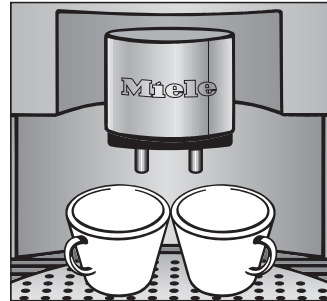

- Set a cup under each coffee dispenser.
- Select "Espresso" or "Coffee".
- Select "2 portions" when displayed.

The coffee system makes two portions of espresso or coffee with a few seconds in between.

Keep the cups under the dispenser until the main menu shows in the display.

## Making coffee

---

### Espresso and coffee made from ground coffee

After filling the funnel with ground coffee (see "Filling water, beans or ground coffee - Filling ground coffee"), the display shows:

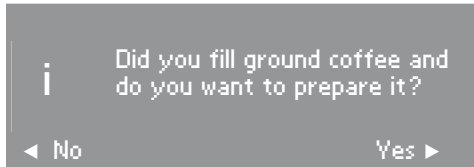

- Select "Yes".

Select "No" if no ground coffee is filled in the funnel. Otherwise the coffee system assumes that ground coffee is in the machine and dispenses only water next time coffee is made.

- Set a cup under the coffee dispenser.

The drink is dispensed through both dispensers at the same time.

- Select "Espresso" or "Coffee".

The coffee system brews the espresso or coffee and the drink is dispensed.

Do not open the door during the brewing process. It will damage the machine. The unit will switch automatically back to brewing with beans after preparation.

### Cancelling

- Select "Stop" to cancel the process.

### Preparing two cups at the same time

When using ground coffee, only one portion at a time can be prepared. The unit uses the whole portion of ground coffee which was filled in the funnel to prepare **one** drink.

## Making coffee

---

### Cappuccino and milk froth

#### When using for the first time or using after descaling

The lines were completely drained before the unit left the factory. They will also be drained when the machine is descaled. Before preparing cappuccino or froth, the lines must be filled with water.

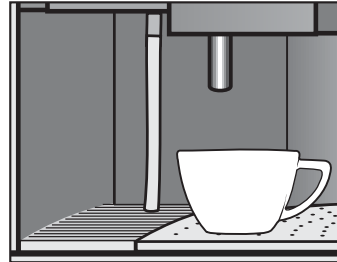

- Set a cup under the cappuccino dispenser.

- Select the "Milk froth" touch control.

The intake hose takes in water from the tank and fills the lines with water. A small amount of water runs from the froth dispenser.

Prompts to clean the froth dispenser appear in the display.

- Confirm by selecting "OK".
- Once the machine stops, select "Milk froth" again.

The froth dispenser dispenses steam and the lines are filled with water.

- Select "Clear" to get back to the main menu.

The coffee system is ready to use.

## Making coffee

---

### Cappuccino

To prepare a cappuccino you need a large ceramic or porcelain cup and a small mug (supplied) of milk.

The best milk froth is achieved with cold skim milk.

Only one cup of cappuccino can be prepared at a time because of the milk frothing process.

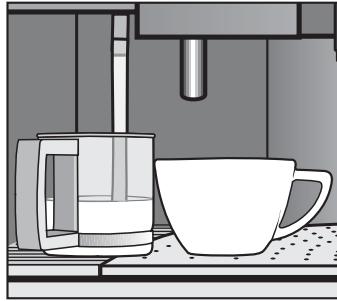

- Set the mug of milk under the intake hose and the cup under the froth dispenser.
- Select "Cappuccino".

The milk is frothed into the cup. At the same time the beans are ground.

Select "Stop" to cancel the milk frothing.

- Once the milk is frothed, set the cappuccino cup under both dispensers and select "OK".

The cappuccino will be prepared.

### Milk froth

If you need additional milk froth, prepare cold skim milk in a stainless steel mug which narrows towards the top.

- Set the supplied glass mug with milk under the intake hose and the stainless steel mug under the froth dispenser.
- Select the "Milk froth" touch control.

The milk is frothed into the stainless steel mug.

- Select "Stop" to cancel the milk frothing.

### After preparing milk froth and cappuccino

Clean the froth dispenser and intake hose immediately after use. If the milk is allowed to dry, the parts may get clogged and difficult to clean. See "Cleaning and Care".

## Adjusting the coffee grinder

The amount of ground coffee determines the strength of the coffee and the quality of the crema.

The amount of ground coffee can be adjusted in the main menu. See "Settings - Grind amount".

To prevent machine damage adjust the coffee grinder **one notch at a time** and let the beans grind before adjusting another notch. Otherwise the machine will be damaged.

### The grinder should be adjusted:

- If the espresso flows too quickly into the cup, the pressure cannot be built up because the beans have been ground too coarsely. The grinder should be adjusted to a finer setting.
- If the espresso only trickles into the cup, the beans have been ground too fine and the coffee will be bitter. The grinder should be adjusted to a coarser setting.
- If the crema is evenly colored but pale, the ground coffee is too coarse.
- If the crema is very dark brown on one side, graduating almost to white on the other, the ground coffee is too fine.

### To adjust the grinder setting

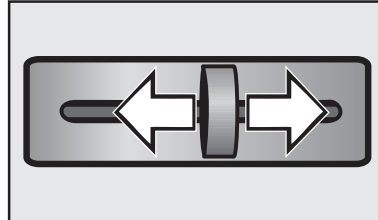

- Push the slide control to the left for a finer grind or to the right for a coarser grind.

You should be able to feel the notches when moving the slide control.

If the slide control will not move:

- Close the machine and dispense a cup of coffee.

Then try to move the slide control again.



## Clock



- Select "Settings".

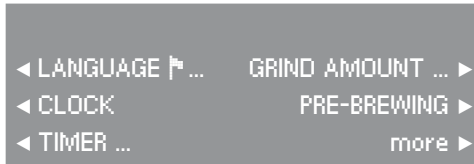

- Select "Clock".

### Setting the time of day

- Select "Enter Time".
- Select "+" or "-" with the right touch controls to select the hours.
- Set the minutes by selecting "Minutes".
- Select "+" or "-" with the right touch controls to select the minutes.
- Select "OK".

The time of day is saved.

## Clock display size

The size of the clock display can be adjusted. The options are "normal" or "large".

- Select the "Size" touch control.

The selected size is highlighted in the display.

- Select the "Size" touch control until the desired size is highlighted.
- Select "OK" to save the selection.

### 12 or 24 hour clock

The clock display can be set to the 12 or 24 hour clock.

- Select the respective touch control.
- The selected display is highlighted.
- Select "OK" to save the selection.

### Clock display on/off

The clock can be displayed or turned off.

If the display is turned on, the time of day is displayed when the machine is turned off.

If the option is set to off, the display turns off after 60 seconds.

- Select "Clock display".

The selected display is highlighted.

- Select "OK" to save the selection.

# Settings

---

## Timer

### Setting a timer

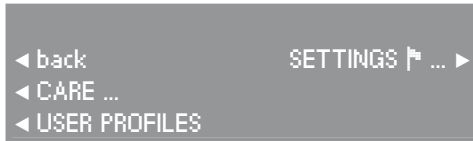

- Select "Settings".



- Select "Timer".
- Select "Setting".

### Turn on at

A specific time of day can be set to turn the machine on, e.g. for breakfast.

- Select "Turning on at".
- Set the hours to when the appliance should turn on by selecting "+" or "-".
- Switch to "Minutes" and repeat.
- Select "OK".

The machine will turn on every day at the selected time.

**If the "Rinse" function was set to "On", the lines will be rinsed when the machine is turned on.**

If the machine is turned on automatically three times and no beverages were dispensed, the machine will no longer turn on automatically. The programmed times stay saved and will be activated again when the machine is manually turned on the next time. This safety measure is designed so that the machine does not turn on every day if the setting was not cancelled before a longer time of absence, e.g. vacationing.

## Settings

---

### Turn off after

The machine will turn off automatically to save energy after a programmed period of time. Time periods between 15 minutes and 6 hours can be selected. If the machine is not used after dispensing beverages, it will turn off after the selected time.

- Select "Turning off after".

For example a 0:15 display means that the unit will turn off after 15 minutes of no use.

- Set the hour when the appliance should turn off by selecting "+" or "-".
- Switch to "Minutes" and repeat.
- Select "OK" to save the selection.

The machine will turn off after the desired time.

**If rinsing is set to "On" and a beverage was already dispensed, the lines will be automatically rinsed before turning off.**

### Turn off at

A specific time of day can be set to turn the coffee system off.

- Select "Turning off at".
- Set the hour when the appliance should turn on by selecting "+" or "-".
- Switch to "Minutes" and repeat.
- Select "OK" to save the selection.

The machine will turn off at the selected time.

- Select "Clear" until the display shows the desired menu.

**If rinsing is set to "On" and a beverage was already dispensed, the lines will be automatically rinsed before turning off.**

## Settings

---

### Activating a timer



- Select "Settings".

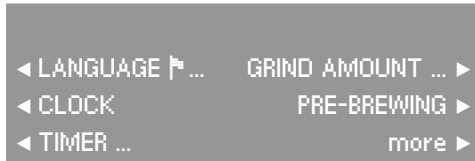

- Select "Timer".

The timer function "Turning on at" or "Turning off at" can be activated or deactivated.

- Select "Activate".
- Select "On" to activate the desired function.

Select "Off" to deactivate the desired function. The selected times in the function will stay stored in the memory.

- Select "OK" to confirm the setting.

## Grind amount

The grind amount can be set, depending on the coffee type, between 0.2 ounces and 0.5 ounces (6 - 14 grams). The more the coffee is ground the stronger the espresso, coffee or cappuccino will be.

The crema is also influenced by the grind amount.

- If the crema has an even but white/yellow coloring, the ground amount might be too little.
- If the crema is dark brown to black in color on the one side and almost white on the other side, the grind amount might be too much.

■ Select the User profile, for which you would like to set the grind amount.

■ Select "Settings".

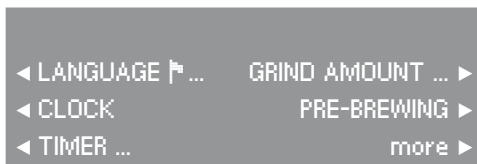

■ Select "Grind amount".

The grind amount can be set to individual preferences for espresso, coffee and cappuccino.

- Select the desired beverage.
- Select the center left or right touch control to set the grind amount to more or less.
- Select "OK" to save the setting in the User profile.
- Select "Clear" until the display shows the desired menu.

## Pre-brewing

During pre-brewing a small amount of water is released onto the ground coffee. After a short time the remaining water is pushed through the ground coffee at a high pressure.

If the function is turned off, the hot water will be immediately pushed at a high pressure through the ground coffee.

Pre-brewing is set to off by default.

■ Select the User profile, for which you would like to set the pre-brewing.



■ Select the "Settings" touch control.



■ Select "Pre-brewing".



The second line shows the currently selected pre-brewing option.

■ Set the desired option and select "OK" to save the setting.

## Settings

---

### Temperature

Five temperatures are available for each beverage, three for hot water. Maximum is the highest temperature, minimum the lowest.

Not every coffee type allows high temperatures. Some types react so sensitively that the crema cannot be properly built.

- Select the User profile, for which you would like to set the temperature.
- Select "Settings" and then "more".

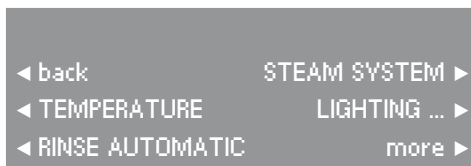

- Select "Temperature".

The temperature can be set individually for espresso, coffee, cappuccino and hot water.

- Select the desired beverage.
- Each beverage shows the currently selected temperature.
- Select the respective touch control until the desired temperature is highlighted.
- Select "OK".

### Rinse automatic

It is important to flush out any residual coffee from the lines when starting to use the machine for the day. If "Automatic Rinsing" is set to "on", the rinsing starts automatically once the machine is turned on and still cold. The lines are rinsed with hot water and in return prewarmed. A message shows in the display.

The machine will also run an automatic rinse, before it switches off, if it has been used to prepare a drink.

The rinse automatic is set to on by default.

#### To turn rinse automatic off/on

- Select "Settings" and then "more".

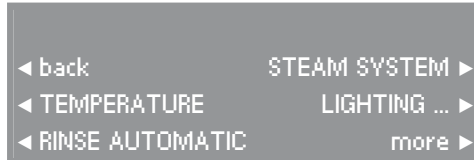

- Select "Rinse automatic".

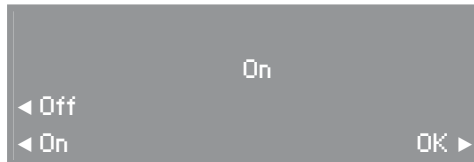

The second line shows if the rinse automatic is turned on or off.

- Select "On" or "Off" and then "OK" to save the setting.

It is recommended to set this option to "On" so that the rinse process cannot be forgotten.

### Steam system

The appliance has two heating systems. They allow for independent preparation of froth/cappuccino or espresso/coffee. The second heating system can be turned off to save energy during the heating phase e.g. if froth is not prepared very often.

When the steam system is turned off and froth or cappuccino is selected, the unit must heat up first to produce steam.  
As long as the coffee system was not completely turned off, the steam system is on.

The steam system is turned on by default.

#### To turn the steam system off

- Select "Settings".
- Select "Steam system".

The second line shows if the steam system is turned on or off.

- Select "On" or "Off" and then "OK" to save the setting.

### Lighting

Lighting sets the type of light used when the appliance is turned on. The lighting can be turned on/off automatically or dimmed to the desired brightness. The dimming functions can be set independently for the upper or lower lighting.

 Caution! Do not look directly or with an optical instrument into the lighting. Laser!

#### To change the lighting

- Select "Settings" and then "more".
- Select "Lighting".
- Select "On during use" or "Dimming".

#### On during use

**On:** The lighting turns on and off when the unit is turned on and off.

**Off:** The lighting stays turned off.

#### Dimming

The brightness of the upper and lower lighting can be set independently of each other.

- Select "Top" or "Bottom".
- Set the brightness by selecting the center touch control to the left or right.
- Select "OK" to save the selection.
- Select "Clear" to get back to "Settings".

## Settings

---

### Total no. coffees

- Select "Total coffee" to check the number of previously dispensed espresso, coffee and cappuccino.

After a few seconds the display switches back to the "Settings" menu or touch "OK".

### System Lock

The coffee system can be locked so that it cannot be used by children or those not familiar with the operating instructions.

To activate the System Lock, it must be set in the settings.

- Select "Settings" and then select "more" twice.
- Select "System Lock".

The second line shows if the System Lock is currently activated or not.

- Select "On" and confirm with "OK".

If "Off" is selected, the unit cannot be locked (safety measure).

- Turn the appliance off with the "On/Off" touch control.
- Select the touch control next to .



- Select "On" and then "OK".

The appliance is now locked and will not operate. The display shows a locked padlock .

### Unlocking the coffee system

- Select the  symbol.
- Select "Off" and then "OK".

The appliance is now unlocked and ready for use.

## Settings

### Water hardness

The hardness of the water used in the coffee system must be determined and programmed into the appliance. The water hardness will determine how frequently the unit must be descaled to maintain the coffee system properly. The machine monitors the volume of water passing through it in conjunction with the hardness of the water and will indicate when descaling is necessary. Your local water authority can tell you the hardness of your tap water or you can measure it yourself using the enclosed test strip.

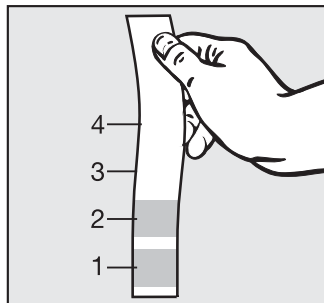

- Dip the test strip in the water for 1 second and shake off any remaining water. The result is visible in about 1 minute.

If the water hardness is greater than 40 gr/gal, the water **must** be descaled more often than displayed. Calcium will build up faster than at a lower water hardness and may damage the machine.

### To set the correct water hardness:



- Select "Settings" and then "more" twice.
- Select "Water hardness".
- Select the center touch control to set the water hardness harder (right) or softer (left).
- Select "OK" to save the selection.

## Settings

---

### User profiles

Up to 10 different user profiles can be entered to accommodate different tastes i.e. different grind amounts, temperature, pre-brewing, portion sizes.

### Creating a user profile

- Select "Settings" and then "more" twice.
- Select "User profiles".

The upper display line shows which user profile is currently set, if different profiles were already created.

The "Standard" profile has standard settings.

- Select "Creating".
- Select the center left or right touch control to select a letter.
- Touch "Select".
- Repeat the step until the desired name is spelled out.

To delete a letter:

- Select the "Backspace" touch control. The last letter will be deleted.

To save a name:

- Select "OK". The display shows the typed name.

The display shows more selections: "Change name", "Delete", "Change"

Not saving a name:

- Select the "Clear" touch control.

### Change name

- If you would like to change a name, touch "Change name" and then the touch control next to the name to be changed.
- Type in the name as described in "Creating a user profile" and select "OK".
- Select "Clear" to go back to the previous screen.

### Delete

To delete the user profile completely

- Select the "Delete" touch control.
- Select the touch control next to the name to be deleted.
- Select "Yes" if you are sure you would like to delete the selected name.

The selected name will be deleted from the list.

### Change

The appliance can be set so that it changes back automatically to the standard profile or that the once set user profile is maintained.

- Select "Change".
- Select from:

**Never:** The unit keeps the once selected user profile until another user profile is selected.

**At turning on:** Every time the coffee maker is turned on, it selects automatically the standard user profile, regardless which user profile was last selected.

**After servings:** After each dispensing of a drink the unit switches automatically back to the standard profile.

### Selecting a user profile

- Select "User profile - Standard" and then the desired profile.
- Select "OK".

The "Standard" profile has standard settings.

## Settings

---

### Display

The display contrast and brightness can be adjusted.

- Select "Settings" and then select "more" three times.



- Select "Display".
- Select "Contrast" or "Brightness" and then the setting. The higher the number the higher the contrast or brightness.
- Select "OK" to save the selection.

### Tone options

A tone can be selected to confirm the selection of a touch control.

- Select "Settings" and then "more" three times.



- Select "Tone options".

#### To turn the tone on or off

- Select "Keypad tone" until the desired option is highlighted.

If the keypad tones are turned on, the volume can be adjusted. The higher the number the louder the tone.

- Confirm the selection with "OK".

#### Volume

- Select "Volume" until the desired volume of the keypad tone is highlighted.

### Reset

To select the factory defaults select in the submenu to "Reset all" (all settings back to default: timer, rinse automatic, steam system, lighting, System Lock, water hardness, display, last selected coffee type and all standard profile settings), or the "User profiles".

If you select one of these options

- Select "Yes" to reset to the default settings or "No" to keep the selected settings.

## Setting the serving sizes

---

The flavor of the coffee depends on the coffee and quantity of water used. To ensure the machine uses exactly the amount of water to suit your taste and your cups, there is a choice of two serving sizes for espresso/coffee. The fill height can be programmed.

**Espresso** serving size  
approx. 30 - 125 ml.

**Coffee** serving size  
approx. 30 - 250 ml.

**Hot water** serving size  
approx. 30 - 250 ml.

**Cappuccino** is a combination of milk froth and espresso. When preparing milk froth the froth-time can be individually set. The amount of espresso can be set to approx. 30 - 125 ml.

- Set the desired cup size under the coffee dispenser. For a cappuccino size, set the cup under the froth dispenser first.
- Select the desired drink of which you want to set the water amount. Press and hold the touch control until "Serving setting" is displayed under the drink type.
- Release the touch control.
- Select "OK" once the cup is filled to your desire.

When setting the cappuccino amount set the cup under the dispenser and touch "Cappuccino" until the display shows "Serving setting".

The programmed amount will be dispensed every time the drink is made.

The water flow stops automatically when it reaches the maximum amount possible. The maximum filling quantity will then be saved for the drink.

## Cleaning and Care

Allow the coffee system to cool before cleaning. Danger of burns!

Do not clean the unit with a steam cleaner. Never use cleaners containing chlorides, sand, soda or scouring agents. These will damage the surface.

To avoid mold of coffee waste, clean the unit regularly.

All parts can be cleaned in the dishwasher, except the brew unit and the bean container. When the parts are cleaned in the dishwasher they might get discolored by food residues such as tomatoes.

### Rinse

If you do not wish to rinse the lines automatically, they have to be flushed manually. Rinse them twice daily, once before using the machine and before turning it off for the day.



◀ back SETTINGS ▶  
◀ CARE ...  
◀ USER PROFILES

- In the main menu touch "more" until "Care" shows. Select "Care".
  - Select "System rinse".
  - Select "OK".
- Hot water will flow through and clean the brew unit, hot water and coffee dispensers.
- When finished select "OK", then "Clear" to go back to the main menu.

## Cleaning and Care

---

### Water tank

Empty the water tank daily and refill before preparing the first drink with fresh, cold tap water.

Check if the valve is clean. If the valve has residues on it, the water tank will not connect properly and might leak.

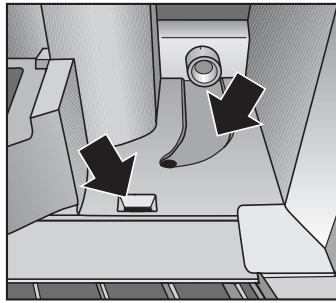

- Clean the niche of the water tank.

### Waste unit

The display shows a message to empty the waste unit. Clean the waste unit **daily**. Coffee waste can mold if there is water in the waste unit from the rinse process.

Line the waste unit with a paper towel to make for easier cleaning.

- Pull the waste unit out.
- Wash the waste container in the dishwasher or by hand with hot water and liquid dish soap and dry with a soft cloth.
- Clean the niche of the waste unit in the machine.
- Push the waste unit completely into the machine.

## Cleaning and Care

### Drip tray

The drip tray contains a sensor which causes the display to show when the tray is full and needs to be emptied. Clean the drip tray **daily**.

Remove the drip tray after the final rinse when no more water runs from the lines.

- Open the door and pull the drip tray out.

The drip tray contains a grid to avoid spilling during transport.

- Wash the drip tray in the dishwasher or by hand with hot water and liquid dish soap, then dry with a soft cloth.

Take care that the metal contacts at the back of the drip tray are clean and dry. If the contacts are soiled or wet the unit cannot detect when the drip tray is full and needs to be emptied.

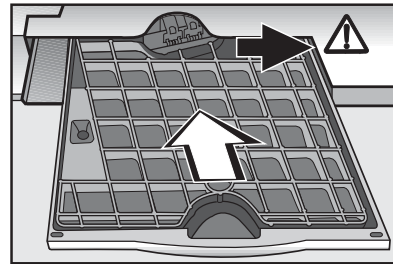

- Push the drip tray with grid along the right edge all way in the machine.
- Close the door.

## Cleaning and Care

---

### Drip catch with metal insert

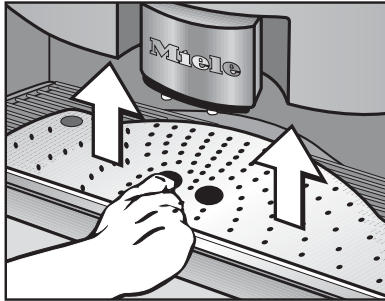

- Take out and clean the drip catch and metal plate.

### Bean container

The bean container must be cleaned **by hand** with hot water and liquid dish soap.

- Pull the bean container out and push the lid back.
- Wash the bean container by hand with hot water and liquid dish soap, then dry with a soft cloth.
- Push the lid back and reinsert the bean container into the machine.

## Cleaning and Care

### Coffee dispenser connector

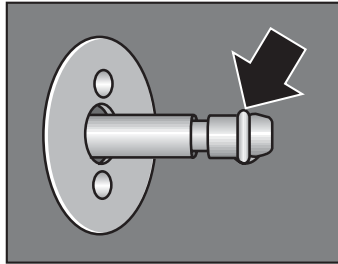

A connector between the brew unit and coffee dispenser is located on the inner door.

- Gently clean the connector regularly with a damp cloth without removing the lubricant for the gasket.
- Lubricate the gasket once a month with the supplied silicone grease.

### Interior and door

- Once all movable parts are removed clean the interior with a solution of hot water and liquid dish soap.

**Dry** ground coffee can be vacuumed.

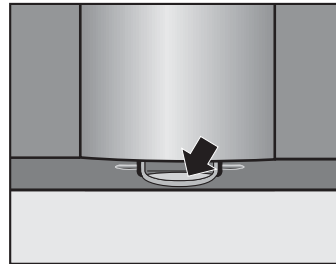

- The lower part of the inner door has a drip tray. Clean the drip tray.

## Cleaning and Care

### Brew unit

Manually clean the brew unit weekly. The movable parts are lubricated and the gaskets will get damaged in the dishwasher.

- Take out the water tank, waste unit and the cover for the ground coffee funnel.

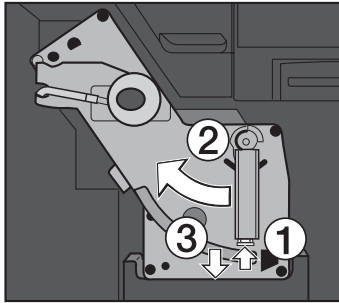

- Press the light colored button on the brew unit handle, ①, and turn the handle to the left, ②.
- Press the brew unit catch, ③, downwards and pull the brew unit out.

The brew unit is not in the correct position if it is hard to pull out. See "Frequently asked questions".

- Clean the brew unit under running warm water. **Do not use soap.**

Leave the handle in position or the brew unit cannot be inserted properly.

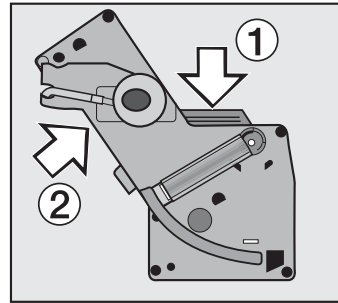

- Rub off any coffee residue from the filters with a sponge. One filter is in the funnel, ①, the second is to the left of the funnel, ②.
- Dry the funnel, ①, to prevent ground coffee from sticking.
- Clean the interior and remove coffee residues. Dry coffee grounds can be vacuumed.
- Push the brew unit in the track straight into the appliance.

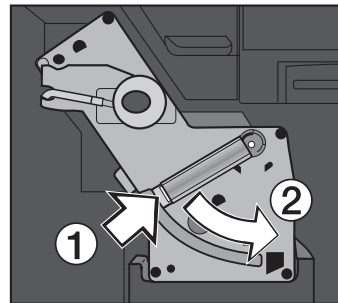

- Press the light colored button on the brew unit handle, ①, and turn the handle to the right, ②.

## Cleaning and Care

### Cleaning/Degreasing the brew unit

Depending on the fat content of the coffee, the brew unit can clog. Clean the brew unit approx. every 200 cups with the enclosed detergent tablets. They are specially developed for the coffee maker to optimize the degreasing. The cleaning tablets can be purchased from Miele.

As a reminder the display shows "Cleaning must be started" after 200 cups and then until the machine is cleaned. The cleaning process takes about 6 minutes.

- Select "Care".
- Select "Cleaning" and then "OK".

The display guides you through the cleaning process. Please follow the single steps.

- Set a 1 quart container under the coffee dispenser.

The interior is also rinsed, therefore the drip tray must be emptied.

When the display shows:

### **Please drop the cleaning tablet in the funnel for ground coffee**

- Take out the funnel cover and open the funnel lid.

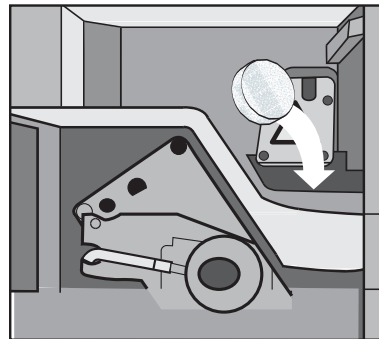

- Insert the cleaning tablet in the funnel.
- Close the lid, reinsert the cover and close the door.
- Select "OK".

Follow the display messages.

When the display shows:

### **Process finished. Please confirm.**

The brew unit is cleaned and rinsed.

- Select "OK" and then "Clear" to go back to the main menu.

## Cleaning and Care

### Froth dispenser/Intake hose

Clean the froth dispenser after each use, otherwise they may become blocked with dried milk and hard to clean.

Rinsing does not replace cleaning in the dishwasher.

- Select "Care".
- Select "Rinse system".
- Set a glass with water under the intake hose and select "OK".

The intake hose takes in the water and rinses it.

### Cleaning in the dishwasher

To clean the froth dispenser in the dishwasher, take the parts from the machine. Regular cleaning in the dishwasher is important, so that the froth dispenser does not clog over time, when milk is not removed during rinsing.

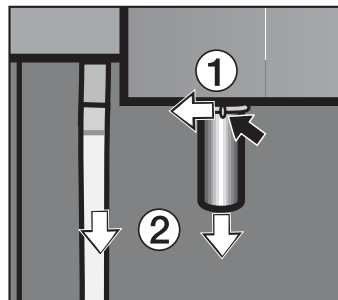

- Turn the cover above the spout to the left, ①.
- Pull the froth dispenser out of the machine, ②, holding it by the spout and the intake hose.

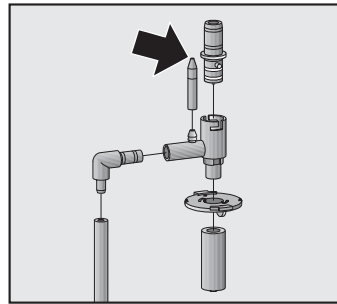

- Pull all pieces apart. Remove the piece with the gaskets by turning and pulling it apart.
- Insert the pieces in the dishwasher and then lubricate the gaskets with the supplied silicone grease.

Take care that the small holes of the single pieces are not clogged (see arrow). Pinch the soft parts to loosen the soiling, then blow them out. Do not use a needle to remove residues, the parts may get damaged.

## Cleaning and Care

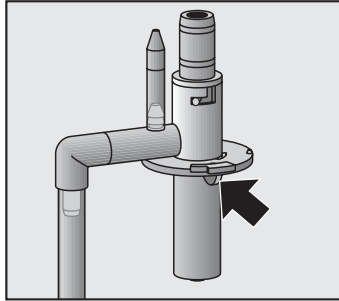

- Reassemble the parts as shown. Take care that the raised parts (see arrow) point downwards and,

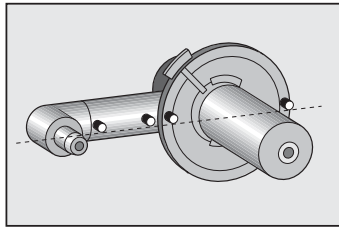

- that the marks are lined up.

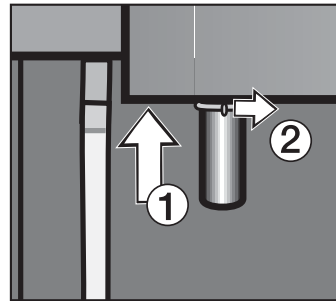

- Push the froth dispenser into the machine from underneath, ①, and turn the cover above the spout to the right, ②.

Do not use the machine without the froth dispenser installed.

Steam will spit uncontrollably.  
Danger of scalding and machine damage.

## Cleaning and Care

---

### Exterior

The front of the appliance can be cleaned with a sponge and a solution of warm water and non abrasive liquid dish soap. Dry with a soft cloth.

Only use a slightly damp sponge when cleaning the controls. Water could penetrate into the electronics and cause damage.

Never use abrasive cleaning agents. They will damage the machine.

**Wipe any spills from descaling immediately!**

### Stainless steel surfaces

Stainless steel surfaces can be cleaned using a non-abrasive stainless steel cleaner.

To help prevent soiling, a conditioner for stainless steel can also be used. Apply sparingly and with even pressure.

### Stainless steel colored controls

Clean the buttons and knobs with a sponge and a solution of warm water and liquid dish soap. These controls may become discolored or damaged if not cleaned regularly. Do not use a stainless steel cleaner on the knobs or buttons. Clean immediately after use.

## Descaling the appliance

The coffee system must be descaled regularly. The appliance will display a reminder message to descale and will eventually lock if not descaled.

The display will show "50 drinks remaining - descaling must be started". This message will now appear after each preparation. If the counter has elapsed to 0, the appliance will be locked.

Select "Descale" to start the descaling immediately. The descaling takes about 20 minutes. If you want to continue at a later point in time, turn the unit off. The appliance can only be used again once descaling is performed.

Only use the **enclosed descaling tablets** for descaling. They are specially developed for the coffee system to optimize the descaling. The descaling tablets can be purchased from Miele. Other agents may damage the machine and affect the taste of coffee and hot water. The machine could also be damaged.

Use the supplied descaling funnel to protect the appliance front from the descaling agent. Clean up any **descaling spills** immediately to avoid damage to the appliance front. Thoroughly clean the water tank and the drip tray of descaling residues.

### Descaling

- To descale the unit before it is heated up, select "Descaling" in the main menu.
- To start the descaling process before prompted by the machine (e.g. because of very hard water), select "Care".
- Select "Descaling" and then "OK".

The display prompts the user through the single steps of the descaling process. Follow the prompts.

If the descaling is started while the machine is still hot, the appliance will cool down for 10 minutes before the descaling begins.

The descaling process cannot be cancelled once "OK" is selected. The process now needs to be completed. This is a safety feature to ensure the process will be completed. It is important for best results and the longevity of the machine.

## Descaling the appliance

---

- The display will prompt you through the next steps:
  - to fill the descaling agent into the water tank
  - take the water tank out
  - fill the water tank with fresh lukewarm tap water to the mark . If not filled to the mark, the descaling will be cancelled prematurely and incomplete

Dissolve two of the enclosed descaling tablets in the water. Close the water tank and insert into position.

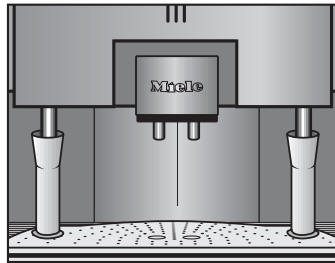

- Set the descaling funnels under the coffee dispensers. Set the funnel in the holes of the drip tray so the dispensed liquids are guided in the drip tray.

During the descaling process the descaling solution will flow from the hot water and coffee dispensers. The machine rests briefly to allow the solution to take affect before dispensing again.

- **Please fill with fresh water:** Take the water tank out, rinse out any descaling residues thoroughly with water. Fill with fresh water to the  mark.

During rinsing water runs from the dispensers. When the display shows **Please empty the drip tray:** Empty the drip tray. Since the machine is also rinsed inside, the drip tray needs to be emptied to continue rinsing.

When the display shows: **Process finished:** Descaling is complete. Follow the prompts in the display. The appliance is rinsed a final time.

Since the lines are drained during descaling, they must be filled with water before the next use. See "Making coffee - Cappuccino and milk froth".

## Frequently asked questions

Repairs to electrical appliances should only be carried out by a suitably qualified person in accordance with local and national safety regulations. Repairs and other work by unqualified persons could be dangerous. The manufacturer cannot be held responsible for unauthorized work.

### Machine Problems

#### The light does not illuminate when the appliance is turned on.

- |  |  |
|--|--|
| <ul style="list-style-type: none"> <li>- Is the unit locked?</li> <li>- Is the lighting turned off?</li> </ul> | <ul style="list-style-type: none"> <li>- See "Settings - Lighting". If not, the light bulb has burnt out. Contact Miele's Technical Service Department.</li> </ul> |
|--|--|

#### The heating phase takes a long time.

<p>When the door is opened during the heating up phase, e.g. to fill the water tank, the heating element turns off. The unit heats only with the door closed.</p>	<p>Keep the door closed during the heating phase.</p>
---	---

#### The light turns off suddenly.

The light turns off automatically when the machine has not been used for 10 minutes.

#### The display messages are difficult to read.

<p>The contrast or brightness of the displays are too low / high.</p>	<p>Adjust the display contrast / brightness. See "Settings - Display".</p>
---	--

#### The display remains dark.

- |                               |  |
|-------------------------------|--|
| <p>The unit has no power.</p> | <ul style="list-style-type: none"> <li>- The main switch is turned off.</li> <li>- The machine is not plugged in.</li> <li>- Check that the fuse had not blown or is defective. If the fuse has blown contact Miele's Technical Service Department.</li> </ul> |
|-------------------------------|--|

## Frequently asked questions

### The unit suddenly turns off.

- |  |   |
|--|---|
| <ul style="list-style-type: none"><li>- Is the machine programmed to switch off after a programmed time?</li><li>- The water temperature could be too high.</li><li>- There could be pebbles within the coffee beans. The unit shuts off after 20 secs. to avoid damages.</li><li>- Is the machine plugged in?</li></ul> | <ul style="list-style-type: none"><li>- The machine goes into standby mode when not used for a programmed time. See "Settings - Timer - Turn off after".</li><li>- The unit is locked until the water has cooled.</li><li>- Call Miele's Technical Service Department.</li><li>- Plug in the machine.</li></ul> |
|--|---|

### The door cannot be closed.

Check if all containers are properly inserted.

### The door is hard to open and close, and the gasket of the connector is pulled off.

Adjust the door with the door hinges. See "Installation - Adjusting the door hinges".

### The gasket of the coffee dispenser connector is damaged and leaking.

- |   |  |
|---|--|
| <ul style="list-style-type: none"><li>- The gasket is worn.</li><li>- Check the door. Is the alignment off from damage to the gasket?</li></ul> | <ul style="list-style-type: none"><li>- Change the gasket with a new one (supplied).</li><li>- Adjust the door with the door hinges. See "Installation - Adjusting the door hinges".</li></ul> |
|---|--|

### The grind control lever will not move.

Close the unit and prepare a coffee/espresso. The grind grade can now be reset.

### The brew unit cannot be taken out.

The brew unit is not in the correct position.	Close the door and turn the appliance on. The brew unit will position itself into the correct position.
---	---

### The cover of the ground coffee funnel cannot be pushed in properly.

Close the lid of the ground coffee funnel.

## Frequently asked questions

### Preparing / dispensing problems

#### No water, steam or milk is dispensed from the froth dispenser.

- |  |  |
|--|--|
| <ul style="list-style-type: none"> <li>- The water tank is not correctly inserted.</li> <li>- The dispenser is clogged.</li> </ul> | <ul style="list-style-type: none"> <li>- Take out the water tank and reinsert it.</li> <li>- Clean the froth dispenser as described in "Cleaning and Care - Froth dispenser/Intake hose".</li> </ul> |
|--|--|

#### The grinding sounds louder than usual.

- |   |  |
|---|--|
| There could be pebbles within the coffee beans. | Turn off the unit immediately.<br>Contact the Miele's Tech. Service. |
|---|--|

#### The grinding is quieter than usual.

- |  |  |
|--|--|
| The coffee bean container is empty. The respective message appears in the display. | Wait until no sound is heard and refill the coffee bean container. |
|--|--|

#### The coffee/espresso flows too fast into the cup.

- |                                      |   |
|--------------------------------------|---|
| The grind control is set too coarse. | Set the grind control to a finer grind. |
|--------------------------------------|---|

#### The coffee/espresso flows too slow into the cup.

- |                                    |   |
|------------------------------------|---|
| The grind control is set too fine. | Set the grind control to a coarser grind. |
|------------------------------------|---|

#### The coffee/espresso is not hot enough.

- |  |   |
|--|---|
| <ul style="list-style-type: none"> <li>- Were the supply lines pre-heated?</li> <li>- The temperature is set too low.</li> <li>- Check if the brew unit is clogged.</li> </ul> | <ul style="list-style-type: none"> <li>- The smaller the cup, the more important it is to pre-heat.</li> <li>- Check on what temperature range the coffee type is set.</li> <li>- Clean the brew unit.</li> </ul> |
|--|---|

#### No drink is prepared although the beans were grinded and enough water is in the container.

- |   |  |
|---|--|
| <ul style="list-style-type: none"> <li>- The grind control is set to the finest or the grind amount is set to the maximum.</li> <li>- The process is timed, the process might need so long, there is no time for brewing any more.</li> </ul> | <ul style="list-style-type: none"> <li>- Set the grind control or the grind amount to a different position.</li> </ul> |
|---|--|

## Frequently asked questions

### **The steam heating system is turned off but steam can still dispensed.**

Steam can be dispensed as long as the steam heating system is heated. Once it has cooled, steam can only be dispensed once the steam system has heated.

### **The coffee dispensing is interrupted.**

The water tank is empty.

Refill the water tank with fresh cold tap water.

### **Instead of coffee only water is dispensed.**

- |  |  |
|--|--|
| <ul style="list-style-type: none"><li>- The beans may have gotten stuck.</li><li>- The ground coffee funnel cover was opened and closed and a preparation with ground coffee was selected but no ground coffee was inserted.<br/>The coffee system switches automatically back to beans use after the preparation.</li></ul> | <ul style="list-style-type: none"><li>- Pull the bean container out and push it back in.</li></ul> |
|--|--|

### **The drip tray is empty but a message to empty it is displayed.**

- |   |   |
|---|---|
| <ul style="list-style-type: none"><li>- The metal contacts are soiled or wet.</li><li>- Check if the drip tray is inserted correctly.</li></ul> | <ul style="list-style-type: none"><li>- Clean and dry the contacts.</li><li>- Insert the drip tray as described in "Cleaning and Care - Drip tray".</li><li>- Turn the machine off and on again with the main switch.</li><li>- If the message still appears contact Technical Service.</li></ul> |
|---|---|

## Frequently asked questions

### **The machine does not rinse when turned on although the automatic rinse feature is set to "On".**

When the machine is still at a temperature of about 140°F (60°C). The machine will not rinse when it's too hot.

### **The water dispensing stops when programming the serving size.**

- |   |  |
|---|--|
| <ul style="list-style-type: none"> <li>– There was not enough water in the tank. The dispensed water amount will not be saved.</li> <li>– If the maximum water amount is dispensed, the water flow stops automatically. The maximum water amount is saved.</li> </ul> | <ul style="list-style-type: none"> <li>– Fill the water tank before programming the serving size.</li> </ul> |
|---|--|

### **Water is in the waste unit.**

This is not a fault.

This is residual water from the cleaning process.

### **"Coffee water" is in the waste unit.**

If the grind control is set to very fine, there might be coffee water in the waste unit.

If the grind control is not set to very fine, contact Technical Service.

### **The descaling process was started accidentally.**

The descaling process cannot be cancelled once it is started. The process needs now to be completed. This is a safety feature to ensure the process will be completed. It is important for best results and the longevity of the machine.

### **The preheating time is increased, the water flow amount is not correct and the unit performs less?**

The machine needs to be descaled.

See "Descaling the appliance".

### **No water flows from the spouts.**

The filters in the brew unit are clogged.

Rub any residue off the filters with a sponge.

## Frequently asked questions

### The brew unit or waste unit could not be pulled from the machine.

- |  |   |
|--|---|
| <ul style="list-style-type: none"> <li>– The brew unit is not in the basic position.</li> <li>– The door was opened during grinding or brewing.</li> </ul> | <ul style="list-style-type: none"> <li>– Close the door. The brew unit automatically gets into the basic position.</li> </ul> |
|--|---|

### No crema has formed or it is "different".

- |   |  |
|---|--|
| <ul style="list-style-type: none"> <li>– Check if the grind control is set too coarse or too fine.</li> <li>– Check what temperature range the coffee type is set. If the temperature is too high, there are black areas in the crema.</li> </ul> | <ul style="list-style-type: none"> <li>– The coffee is not fresh enough.</li> <li>– The coffee is unsuitable for use in this machine. See "Filling the beans container".</li> <li>– The coffee dispensers are set too high.</li> </ul> |
|---|--|

### Too much crema has formed and is above the coffee dispensers.

Some coffee types produce too much crema when the coffee / espresso temperature is set to the maximum and the amount of ground coffee is too much.	Lower the temperature and amount of ground coffee.
--	--

### The milk froth does not flow but "spits".

Before using for the first time the water lines need to be filled. See "Making coffee - Cappuccino and milk froth".

### When preparing milk froth for the first time, the milk is spit from the mug.

The door was opened during the heating phase. High steam pressure has built making the steam dispensed too strong when the valve is opened.	Keep the door closed during the heating phase.
---	--

## Frequently asked questions

---

### "F" messages

#### The message F 10 or F 17 shows in the display.

No water is dispensed.

- The water tank is not inserted properly. Take it out and reinsert correctly.
- The water tank was not filled correctly during the descaling process. Fill the water tank up to the correct mark.
- After fixing the fault, the machine turns off then on again. Start the desired preparation again.
- If the message still appears contact Technical Service.

#### F 73 shows

The brew unit is clogged and cannot reset to the correct position.

- Select "Clear".
- Take out and clean the brew unit. See "Cleaning and Care - Brew unit".
- Reinsert the brew unit and close the door.
- If the message still shows contact Technical Service.

## After sales service

---

In the event of a fault which you cannot easily fix yourself, please contact the Miele Technical Service Department at the contact information on the back of this booklet.

When contacting the Technical Service Department, please quote the model and serial number of your appliance given on the data plate inside the appliance.

### **MieleCare**

**MieleCare**, our Extended Service Contract program, gives you the assurance of knowing that your appliance investment is covered by 5 years of worry free ownership.

**MieleCare** is the only Extended Service Contract in the industry that guarantees repairs by a Miele Authorized Service Provider using genuine Miele parts. Only genuine Miele parts installed by factory trained professionals can guarantee the safety, reliability, and longevity of your Miele appliance.

Please note that unless expressly approved in writing by Miele's Service department, Extended Service Contracts offered by other providers for Miele products will not be recognized by Miele. Our goal is to prevent unauthorized (and untrained) service personnel from working on your Miele products, possibly doing further damage to them, you and/or your home.

To learn more about **MieleCare** Extended Service Contracts, please contact your appliance dealer or visit us online at:

**[www.store.miele.com](http://www.store.miele.com)**

**Miele**

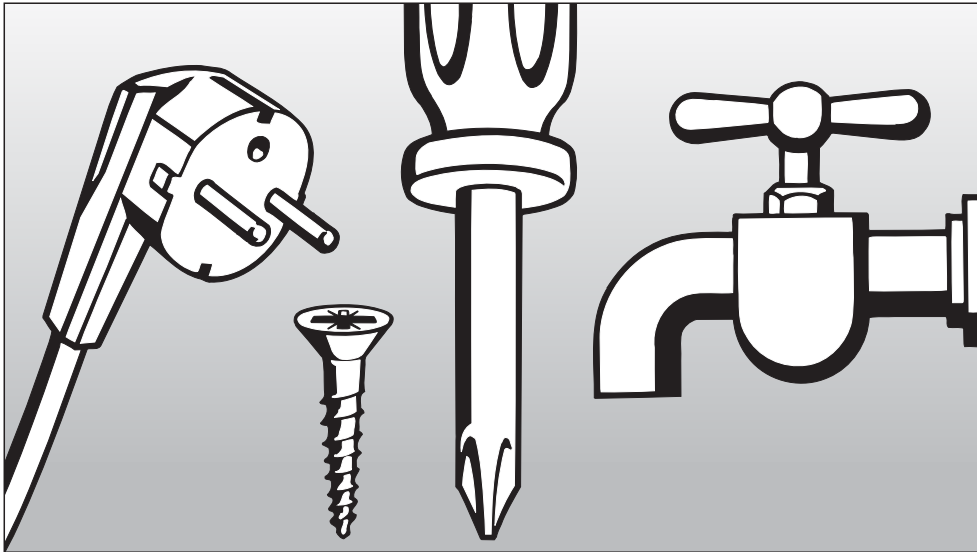

Installation Instructions

## Caring for the environment

---

### **Disposal of packing material**

The cardboard box and packing materials protect the appliance during shipping. They have been designed to be biodegradable and recyclable. Please recycle.

Ensure that any plastic wrappings, bags, etc. are disposed of safely and kept out of the reach of children.  
Danger of suffocation!

### **Disposal of an old appliance**

Old appliances may contain materials that can be recycled. Please contact your local recycling authority about the possibility of recycling these materials.

Ensure that the appliance presents no danger to children while being stored for disposal. Before discarding an old appliance, unplug it from the outlet, cut off its power cord and remove any doors to prevent hazards.

## Electrical connection

---

Ensure that power is not supplied to the machine while installation or maintenance work is performed.

All electrical work should be performed by a qualified electrician in strict accordance with national and local safety regulations. Installation, repairs and other work by unqualified persons could be dangerous.

The manufacturer cannot be held responsible for unauthorized work.

### Important

The coffee system comes equipped with a 6 ft (1.8 m) power cord with a NEMA 5-15P molded plug for connection to a 120 V, 15 A, 60 Hz power supply.

Verify that the voltage, load and circuit rating information found on the data plate match the household electrical supply before installing the coffee system.

If there is any question concerning the electrical connection of this appliance to your power supply, please consult a licensed electrician or contact Miele's Technical Service Department. See back page for contact information.

**WARNING:  
THIS APPLIANCE MUST BE  
GROUNDED**

## Installation

### Installation options

The coffee system is designed to be built into cabinetry.

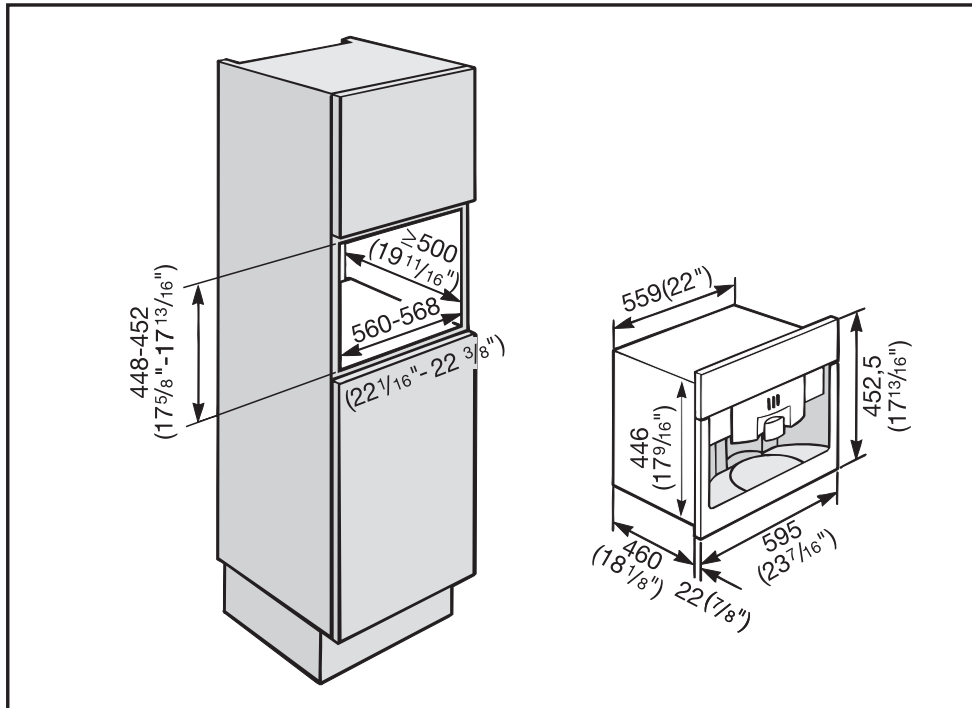

A combination with other Miele built in appliances is possible. If the machine is installed in combination with other appliances, it should be installed with a protective base between the appliance and the unit (exception: installation with a built-in plate warmer).

A special display cabinet is also available from your dealer or Miele, as an installation option.

## Installation

### Installation

Make sure power is not supplied to the appliance while installation or maintenance work is performed. Disconnect the power supply to the work area by unplugging the unit, tripping the circuit breaker or removing the fuse. The coffee system must be installed into cabinetry before being used.

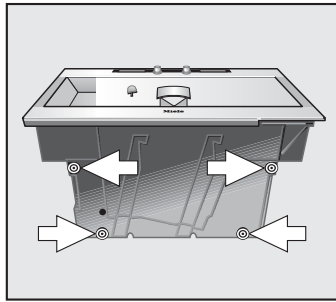

- Unscrew the height adjustable feet on the underside of the machine about 1/16" (2 mm).
- Push the appliance all the way back into the cabinet and center it. If necessary level the unit with the four height adjustable feet.

The feet can be turned out up to 3/8" (10 mm).

- If your cabinet has 3/4" (19 mm) side walls, drill four holes for the mounting.
- Center the unit and turn the screws a little bit in and then out again.
- Take the unit out of the niche and drill four holes at the screw markings (1/16" [2 mm], diameter 3/16" [4.5 mm])
- Plug the appliance into the electrical outlet.
- Push the appliance into the niche.
- Open the door and partially tighten the screws.

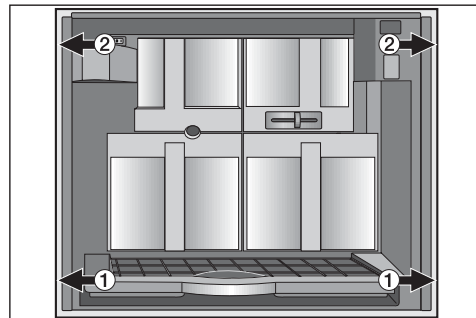

- Carefully turn the lower screws, ①, to center the machine.
- To secure the appliance in the cabinet, tighten the upper screws, ②, by hand. Do not use an electric screwdriver.

## Installation

---

### Adjusting the door hinges

The door hinges can be adjusted if the door cannot be opened easily.

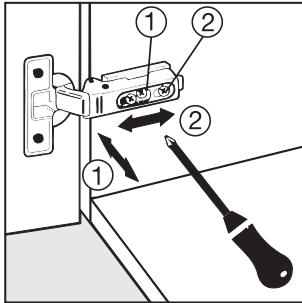

- To adjust the door sideways, ①, turn screw ①.
- To adjust the door to the front or back, ②, turn screw ②.







When contacting the Technical Service,  
please quote the model and serial number  
of your appliance.

---



**Miele, Inc.** (USA)

**National Headquarters**

9 Independence Way  
Princeton, NJ 08540  
Phone: 800-843-7231  
609-419-9898  
Fax: 609-419-4298  
[www.miele.com](http://www.miele.com)

**Technical Service & Support  
Nationwide**

Phone: 800-999-1360  
Fax: 888-586-8056

**Miele Limited** (CDN)

**Headquarters and Showroom**

161 Four Valley Drive  
Vaughan, ON L4K 4V8  
Phone: 800-643-5381  
905-660-9936  
Fax: 905-532-2290  
[www.miele.ca](http://www.miele.ca)  
[info@miele.ca](mailto:info@miele.ca) (general enquiries)  
[professional@miele.ca](mailto:professional@miele.ca) (commercial enquiries)

**MieleCare National Service**

Phone: 800-565-6435  
905-532-2272  
Fax: 905-532-2292  
[service@miele.ca](mailto:service@miele.ca) (technical enquiries)