

CT661

32.63" x 23.63" x 23.0" (H x W x D)

Freestanding counter height refrigerator-freezer for residential use, cycle defrost with deluxe interior and white finish

Highlights:

- Over 5 cu.ft. of storage capacity in a perfectly sized 24" footprint
- Deluxe interior with glass shelves, door storage, and a scalloped wine shelf
- Improved temperature performance with our unique dual evaporator cooling
- Zero degree freezer compartment



Slim counter height dimensions	Ideal 24" footprint offers full 5.1 cu.ft. storage capacity in a slim fit
Fully finished cabinet	Allows the unit to be used freestanding
Zero degree freezer	Frozen food and ice cream stay safe and freezer burn-free in the low temperature freezer compartment
Cycle defrost	This system utilizes user-friendly automatic defrost operation in the fresh food section and efficient manual defrost operation in the freezer compartment
Dual evaporator cooling	Our unique and efficient design separately cools the refrigerator while maintaining zero degrees in the freezer with two evaporators
Adjustable glass shelves	Rearrange your refrigerator space to accommodate all shapes and sizes or remove shelves for a simple clean-up
Fruit and vegetable crisper	Get the longest life and best taste out of produce by storing it in a convenient slide drawer
Door storage	Store tall bottles and condiments right on the door for convenient access
Wine shelf	Removable scalloped wine shelf is included to store champagne and wine bottles
Interior light	Automatically illuminates when you open the door

CT661 Specifications:

Height	32.63"
Width	23.63"
Depth	23.0"
Capacity	5.1 cu.ft.
Ext Depth with Handle	24.63"
Interior Height 1	18.0"
Interior Width 1	21.0"
Interior Depth 1	18.0"
Interior Height 2	5.25"
Interior Width 2	19.0"
Interior Depth 2	11.5"
Comp Step Height	5.5"
Comp Step Width	21.0"
Comp Step Depth	6.0"
Shipping Weight	102.0 lbs.
Energy Usage/Year	365.0 kWh/year
Canadian Electrical Safety	ULC
US Electrical Safety	UL
Amps	1.3
Voltage/Frequency	115 V AC/60 Hz
Reversible	Yes
Door Swing	RHD
Crisper Quantity	1
Shelf Quantity	2
Adjustable Shelf	true
Shelf Type	Glass
Crisper Cover Type	Glass
Crisper Finish	Transparent
Full Door Shelf Quantity	3
Wine Bottle Holder	true
Defrost Type	Cycle
Height to Hinge Cap	32.25"
Depth with door at 90°	45.38"
Thermostat Type	Dial
Light	true
Freon Oz	2.33
Level Legs Quantity	2
High Side PSI	285.0
Refrigerant Type	R134a
Low Side PSI	70.0
Compressor Warranty	5 Years
Parts/Labor Warranty	1 Year

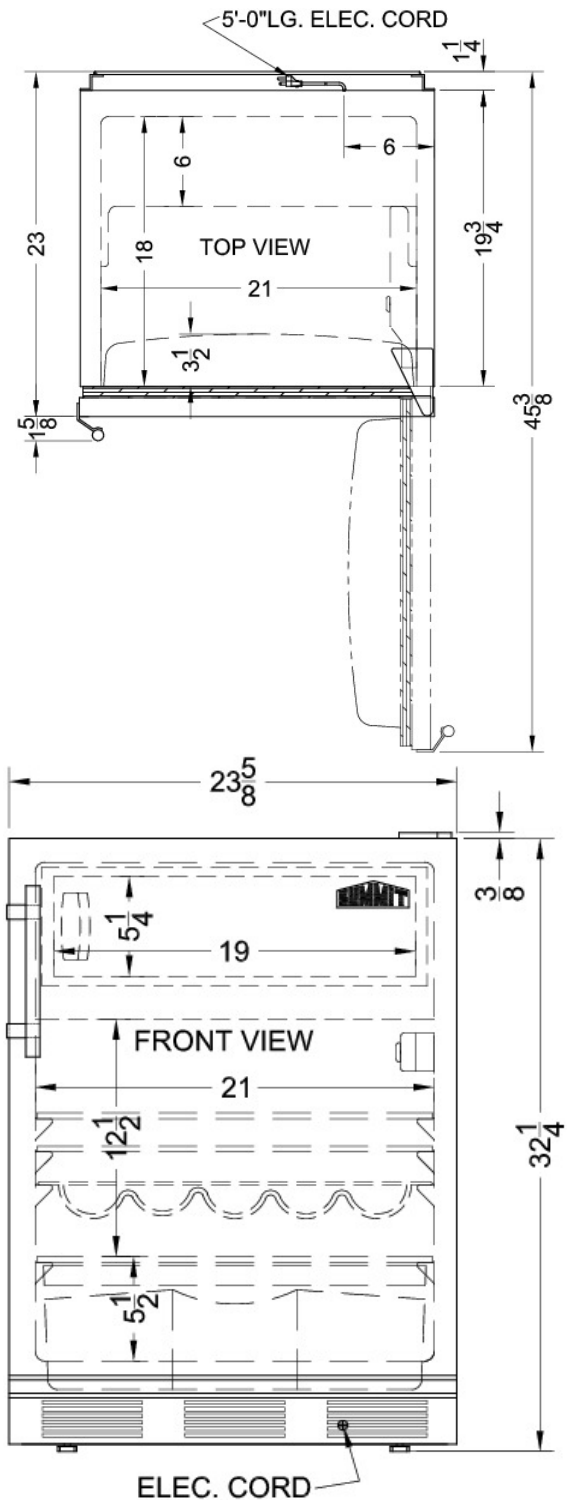

Summit Appliance Division, Felix Storch, Inc.
 770 Garrison Ave • Bronx, NY 10474
 Phone: 718-893-3900 • Fax: 718-842-3093
 Email: info@summitappliance.com