

Operating and Installation Instructions

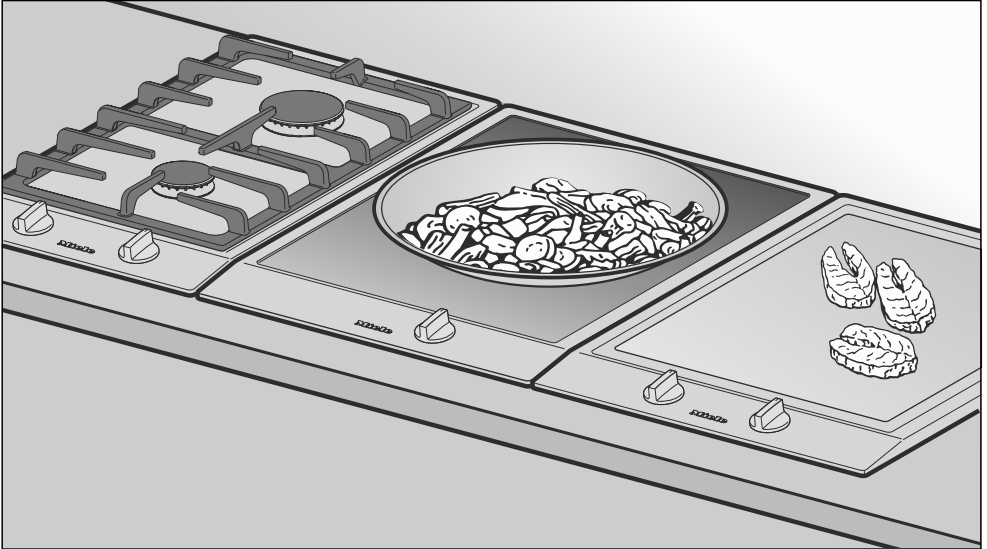

Ceramic combiset with Induction CS 1221

To prevent accidents and
appliance damage,
read these instructions

before
installation or use.

en - US

M.-Nr. 07 346 540

IMPORTANT SAFETY INSTRUCTIONS	4
Guide to the combiset	9
Display	10
Burner data	10
Before using for the first time	11
Clean the combiset	11
Induction	12
How it works	12
Noises	13
Cookware	14
Use	15
Turning the burner On/Off	15
Residual heat indicator	15
Settings	16
Auto-heat	17
Booster function	18
Energy saving tips	19
Safety features	20
Child Safety Lock	20
Safety cut-out	20
Overheating protection	21
Cleaning and care	22
Frequently asked questions	24
Technical Service	26
IMPORTANT INSTALLATION SAFETY INSTRUCTIONS	29
Installation	32
Installation dimensions	33
Installation of multiple appliances	35
Attach the spring clips and support bars	38
Sealing	41
Tiled surfaces	41
Electrical connection	42
Help protect our environment	43

IMPORTANT SAFETY INSTRUCTIONS

WARNING- When using your gas appliance follow basic precautions, including the following:

This gas combiset conforms to all uniform safety codes and regulations.

Read all instructions before installation or use to prevent injury and appliance damage.

These instructions contain important information on installation, safety, use and maintenance of this appliance. They will help you avoid injury and damage to the appliance.

Keep these operating instructions in a safe place and pass them on to any future user.

SAVE THESE INSTRUCTIONS

Correct usage

▶ This appliance is not designed for commercial use. It is intended for use in domestic households and in similar working and residential environments such as:

- shops, offices and similar work environments,
- by customers in hotels, motels, Bed & Breakfasts or similar residential environments.

▶ This appliance is not intended for outdoor use.

▶ Only use the combiset for residential cooking, and for the purposes described in this manual. Other uses are not permitted and can be dangerous.

▶ Persons who lack physical, sensory or mental abilities, or experience with the appliance should not use it without supervision or instruction by a responsible person.

Children

▶ Activate the Child Safety Lock so that the combiset cannot be turned on inadvertently.

▶ Children should not be left unattended in an area where the appliance is in use. Never allow children to sit or stand on any part of the appliance.

Caution: Do not store items of interest to children in cabinets above the appliance. Children climbing on the appliance to reach these items could be injured.

▶ The appliance is hot during use and remains so for some time after being switched off. Keep children away from the appliance.

▶ Ensure that any packing material, is disposed of safely and kept out of the reach of children. Danger of suffocation!

▶ Keep all pots and pans out of the reach of children. Danger of burning or scalding.

IMPORTANT SAFETY INSTRUCTIONS

Technical Safety

► Installation, repair and maintenance work should be performed by a Miele authorized service technician. Work by unqualified persons could be dangerous and may void the warranty.

► Be sure your appliance is properly installed and grounded by a qualified technician.

► Before installing the combiset, check for externally visible damage.
Do not operate a damaged appliance.

► To guarantee the electrical safety of this appliance, continuity must exist between the appliance and an effective grounding system. It is imperative that this basic safety requirement be met. If there is any doubt, have the electrical system of the house checked by a qualified electrician.

► Before installation, make sure that the voltage and frequency listed on the data plate correspond with the household electrical supply. This data must correspond to prevent injury and appliance damage. Consult a qualified electrician if in doubt.

► The combiset is not designed for use with an external timer or a remote control system.

► Do not use an extension cord to connect this appliance to electricity. Extension cords do not guarantee the required safety of the appliance.

► Before servicing, disconnect the appliance from the main power supply.

► Do not operate any appliance with a damaged cord or plug, or if the appliance has been damaged in any manner. Contact Miele's Technical Service Department.

► Under no circumstances open the outer casing of the appliance.

► While the appliance is under warranty repairs should only be performed by an authorized service technician. Otherwise the warranty is void.

► In the event of any damage to the appliance, it must be turned off immediately and disconnected from the main power supply. Contact Miele's Technical Service Department. Do not use the appliance until it has been repaired. Ensure power is not supplied to the appliance until repair work is completed.

► Defective components should be replaced by Miele original spare parts only. Only with these parts can the manufacturer guarantee the safety of the appliance.

IMPORTANT SAFETY INSTRUCTIONS

▶ Do not cook on a broken combiset. Any breakages or cracks in the ceramic surface of the appliance are defects and must be treated as such. If the combiset should break, cleaning solutions and spills may penetrate the broken combiset and create a risk of electric shock. Do not use the appliance until it has been repaired.

▶ Do not use the appliance until it has been properly installed in the countertop.

▶ Be sure that the power cord does not come in contact with any "hot spots" after installation.

Safety

▶ Individuals with a pacemaker or similar medical device:

Please note that an electromagnetic field develops when the combiset is turned on. It is not likely that this will affect the pacemaker or similar device. If in doubt contact the manufacturer of the device or your doctor.

▶ Keep magnetized items, e.g. credit cards, disks, etc. away from the combiset while in operation. Damage may result.

▶ Do not touch the combiset or the surrounding areas during or immediately after use. The combiset may be hot even though it is dark in color. Wait until the residual heat indicators go out.

▶ Protect your hands with oven mitts or potholders when using the appliance. Use only dry, heat resistant potholders. Moist or damp potholders used on hot surfaces can result in steam burns. Do not let the potholder touch the hot heating elements. Do not use towels or other bulky items near the appliance.

▶ Do not heat unopened containers. Built-up pressure may cause the container to burst and result in injury.

▶ Do not flambé under an exhaust hood. Flames could be drawn up into the hood by the suction and the grease filters may ignite.

▶ Do not use the appliance until it has been properly installed in the countertop.

▶ Do not store items on the appliance when not in use. Items could melt or catch fire from residual heat or if the appliance is turned on inadvertently. Always switch the burner(s) off after use.

▶ Do not store aerosols, combustibles or any other easily flammable materials underneath or adjacent to the appliance.

IMPORTANT SAFETY INSTRUCTIONS

- ▶ The combiset is fitted with a cooling fan. Drawers under the combiset are not recommended. If a drawer is fitted directly underneath the combiset, ensure that there is sufficient space between the drawer, its contents and the underside of the appliance in order to ensure sufficient ventilation for the combiset. Do not store small items or paper in the drawer. They could get sucked into the housing by the fan and cause damage or impair cooling. Ensure that no aerosols, combustible liquids or other flammable materials are kept in this drawer. If cutlery inserts are to be placed in the drawer they must be made of heat-resistant material.
- ▶ Metallic items kept in a drawer under the combiset can become hot when the appliance is used for a longer period of time. Use caution.
- ▶ If the combiset is installed above a pyrolytic oven it should not be used during the pyrolytic process. The overheating protection feature of the combiset might be activated.
- ▶ Never cover the burner with a cloth or protective oven foil. If inadvertently turned on or if there is residual heat, a fire could result.
- ▶ When more than one combiset is installed next to each other, be sure not to place hot pots or pans on the center line. This could damage the seal.
- ▶ Be aware of loose fitting or hanging garments when operating the appliance, they may present a fire hazard.
- ▶ Never leave a combiset unattended at high settings or when cooking with oil or fat. Overheated oil could ignite. Always heat oil slowly, monitoring it as it heats.
- ▶ Never heat an empty pan unless the pan manufacturer states that you can do so.
- ▶ Do not use water on grease fires. Smother or use a dry chemical or foam-type extinguisher on any fire or flame.
- ▶ Make certain that the power cords of small appliances do not come in contact with the appliance. The insulation of the cable could become damaged. Danger of electric shock!
- ▶ Be careful not to drop anything on the ceramic surface of the combiset. Even lightweight objects may cause damage.
- ▶ Pot and pan handles should be turned inward and not extend over the countertop to reduce the risk of burns, ignition of flammable materials, and spills.
- ▶ Be careful not to drop anything on the ceramic surface of the combiset. Even lightweight objects may cause damage.

IMPORTANT SAFETY INSTRUCTIONS

▶ Pot and pan handles should be turned inward and not extend over the countertop to reduce the risk of burns, ignition of flammable materials, and spills.

▶ Do not use pots or pans with pronounced edges or ridges on the ceramic combiset. These could scratch the combiset permanently. See "Cookware" for more information. Grains of salt and sand can cause scratches. Make sure that the bases of any pots and pans are clean, free of any fat or oils, and are dry.

▶ To prevent burns and breathing difficulty, allow the combiset to cool before cleaning. Some cleaners may produce toxic fumes if applied to a hot surface.

▶ Keep the combiset clean. Salt, sugar, and grit can cause scratches.

▶ When wiping spills on a hot combiset with a wet sponge or cloth, be careful to avoid steam burns.

▶ Do not let flammable materials, i.e. cooking grease, accumulate on the appliance.

▶ Do not use a steam cleaner to clean this appliance. Steam could penetrate electrical components and cause a short circuit.

▶ Do not allow solid or liquid sugar, pieces of plastic or foil to fall on the burner when hot. If these residues are allowed to cool on the ceramic surface pitting or even cracking may occur.

▶ Any spills should be removed as quickly as possible to prevent them from burning on and becoming difficult to remove.

**SAVE THESE INSTRUCTIONS
AND REVIEW THEM
PERIODICALLY**

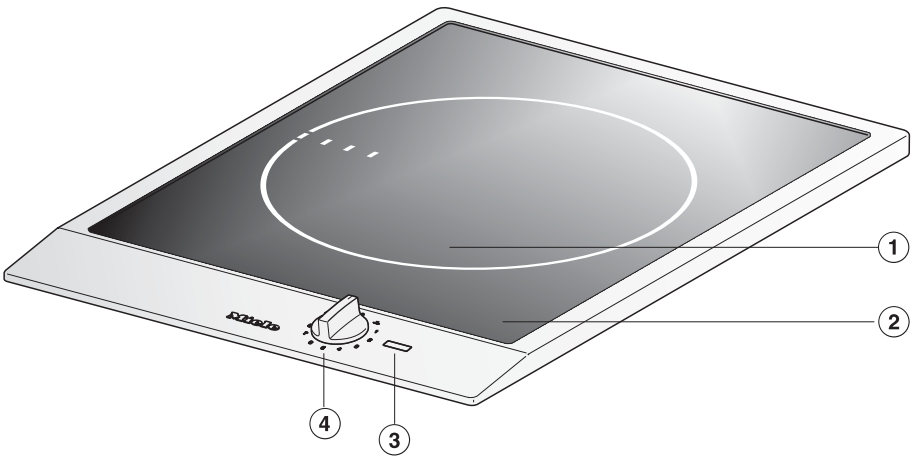

- ① Burner with booster
- ② Display
- ③ Indicators
- ④ Control knob

Indicators



- ⑫
- ⑬
- ⑭

- ⑫ On/Off indicator
- ⑬ Booster indicator
- ⑭ "Residual Heat" indicator

Guide to the combiset

Display

- U* = No pan on burner or pan is unsuitable
- R* = Auto-heat
- F* = Fault (see "Frequently asked questions")
- E / Ø* = Safety cut-out feature (see "Safety features")
- I* = Booster activated
- H* = Overheating protection (see "Safety features")
- L* = Child safety lock (see "Safety features")

Burner data

CS 1221		
Minimum to maximum diameter*	Rating in watts 240 V**	
7" - 11 3/4" (18 cm - 30 cm)	normal:	2,400
	with Booster:	3,700

* Pots with a bottom diameter in the stated range may be used.

** The stated power may vary depending on the size and material of the cookware.

Before using for the first time

Clean the combiset

- Before using for the first time, clean the appliance with a damp cloth and dry with a soft cloth.

Do not use liquid dish soap to clean the combiset, this may cause permanent blue discolorations.

Heat the appliance

When the combiset is first connected to the power supply and after a power failure, all indicators in the display will light up for approx. 1 second. The combiset can be used as normal once the indicators go out.

Metal components of the appliance have a protective coating which may give off a slight odor the first time the appliance is heated.

The smell will dissipate after a short time and does not indicate a faulty connection or appliance defect.

Induction

How it works

An induction coil is located under the burner. When the burner is switched on, this coil creates a magnetic field which impacts directly on the base of the pan and heats it up. The burner itself is heated indirectly by the heat given off by the pan.

Induction burners only work when a magnetic based pan is placed on it (see "Cookware").

Induction automatically recognizes the size of the pan, i.e. heat is only generated in the area covered by the base of the pan.

The burner will not work:

- if it is switched on without a pan in place, or if the pan is unsuitable (non-magnetic base).
- if the diameter of the pan is too small.
- if the pan is taken off the burner when it is turned on.

If this happens, **E** will flash in the display.

If a suitable pan is placed on the burner within 3 minutes, **E** will go out and you can continue cooking as normal.

If no pan or an unsuitable pan is placed on the burner, the burner and the combiset will switch off automatically after 3 minutes. **E** will flash alternately with **L** in the display.

To use the burner again as normal, first turn the control knob to "0".

Be careful not to place cutlery or other metal objects on the combiset. When the appliance is switched on, or when there is residual heat present, there is the risk of metal objects heating up quickly. Beware of burns. Depending on the material, other objects left on the combiset could also melt or catch fire. Turn off the burner after use.

Noises

When using an induction burner, the following noises can occur in the pan, depending on what it is made of and how it is constructed.

- Higher power settings may cause a buzz. This will decrease or cease altogether when the power setting is reduced.
- If the pan base is made of layers of different materials (e.g. a sandwiched base), a cracking sound may be heard.
- You may hear a clicking sound from the electronic switches, especially on lower settings.

The appliance has a cooling fan to help extend the life of the electronics. When the combiset is being used at high levels for a long period of time, this will come on and you will hear a whirring sound. The fan may continue to run after the appliance has been switched off.

Induction

Cookware

Suitable pans include:

- stainless steel pans with a magnetic base
- enameled steel pans
- cast iron pans

Unsuitable pans:

- stainless steel pans without a magnetic base
- aluminum and copper pans
- glass, ceramic or earthenware pots and pans

To test whether a pot or pan is suitable for use on an induction combiset, hold a magnet to the base of the pan. If the magnet sticks, the pan is suitable.

Unless the pan manufacturer states that you can do so, do not use pans with very thin bases on this combiset, and never heat empty pans. This could damage the appliance and cookware, and effect the uniformity of the cooking.

Pan size

To make optimum use of the burner, choose cookware that fits between the inner and outer marking of the burner. If the base diameter of the pan is smaller than the inner marking, the induction heating will not work. The burner will behave as if it has no pan on it.

Turning the burner On/Off

- To turn the burner **on**, press the control knob down and turn it **clockwise** ① to the desired setting.

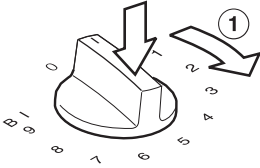

- To turn the burner **off**, turn the control knob **counterclockwise** ② to "0".

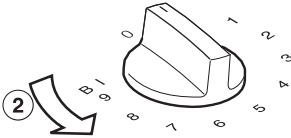

Residual heat indicator

The residual heat indicator will go out once the combiset has cooled to a safe temperature.

As long as the residual heat indicator is lit do not touch or place any heat sensitive items on the burner. Danger of burns, and fire hazard.

Do not turn the burner on without pressing the control knob down, and do not turn the knob past "B I" to reach "0".

When the combiset is turned on the On/Off indicator lights up. Once the combiset has reached a factory set temperature the residual heat indicator will light.

When the combiset is turned off the On/Off indicator will go out.

Use

Settings

Use for	Power level*
Melting butter, chocolate, etc. Dissolving gelatin Prepare yogurt	1 - 2
Warming small quantities of food or liquid Keeping delicate dishes warm Cooking rice, Thawing frozen vegetables	1 - 3
Warming liquid or half-set foods Thickening sauces, e.g., hollandaise sauce Cooking rice pudding	2 - 4
Defrosting frozen foods Steaming vegetables, fish, etc. Cooking pasta, soups, etc. Steaming grains	3 - 5
Boiling and continued cooking of large quantities of food	5 - 6
Gently sautéing fish, cutlets, sausages, fried eggs, etc. (without smoking the oil/fat)	7
Frying pancakes, crepes, etc.	7 - 8
Boiling large quantities of water Parboiling	9

* These settings are intended as guidelines only. When cooking with large pots, large quantities of food/liquid or without using a lid, a higher setting is needed. For smaller quantities select a lower setting.

Auto-heat

When Auto-heat has been activated, the burner switches on automatically at the highest setting and then switches to the continued power level which was selected. The "heat-up" time depends on which continued power level has been chosen (see table).

Continued power level*	Heat-up time (approx.) min : sec
1	0 : 15
2	0 : 15
3	0 : 25
4	0 : 50
5	2 : 00
6	5 : 50
7	2 : 50
8	2 : 50
9	-

The higher continued cooking settings are generally used for frying, a short heat-up time is needed to heat up the pan initially.

Taking a pan off the burner while Auto-heat is in operation interrupts the function. It will resume if a pan is placed back on the burner within 3 minutes.

Activating Auto-heat

- Turn the control knob counterclockwise as far as it will go and hold until an **H** appears in the display.

If the knob is held too long, an **L** will appear in the display and the Lock is activated (see "Child safety lock").

- Turn the control knob clockwise to the desired continued power level.

If a continued power level is not selected within 5 seconds, the Auto-heat feature is not activated.

Once Auto-heat has been activated the continued power level must be set within 10 seconds. After this time the level cannot be changed.

Changing the continued power level after 10 seconds will deactivate the Auto-heat function.

During the Auto-heat phase an **H** will show in the display.

Use

Booster function

The burner is equipped with a booster function to temporarily increase the power level. This boost is intended to quickly bring large quantities of water to the boil, e.g. cooking pasta. When the Booster is activated the burner will operate with extra power for 10 minutes.

Once the booster time has elapsed the burner will automatically revert to power level 9. The **B** indicator and *!* in the display will go out.

Taking a pan off the burner while the booster is in operation interrupts the booster function. It will resume if a pan is placed back on the burner within 3 minutes.

To activate the Booster

- Turn the control knob past power level 9 to BI, then turn back to level 9.

! appears in the display and the **B** indicator lights up.

To deactivate the Booster function

The booster function can be turned off early if desired.

- Turn the control knob past power level 9 to BI and then back to 9; or simply reduce the power level.

Energy saving tips

- Whenever possible, keep pots and pans covered while cooking. This helps keep in the most possible heat.

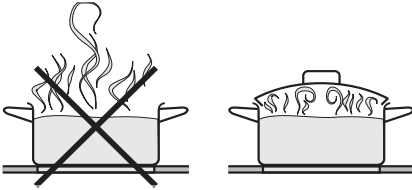

- When cooking small quantities of food, use a small pot or pan. This will required less energy to heat up than a large pot.
- Cook with a small amount of water.
- Using a pressure cooker will greatly reduce cooking time.
- Lower the flame after browning or parboiling.

Child Safety Lock

Keep children away from the combiset for their own safety.

The combiset has a Child Safety Lock to prevent children from turning on the burner.

To activate the Child Safety Lock:

- Turn the control knob counterclockwise as far as it will go, and hold until **L** appears in the display.

If the control knob is touched after the lock is activated an **L** will appear in the display for 3 seconds.

To deactivate the Child Safety Lock:

- Turn the control knob counterclockwise as far as it will go, and hold until the **L** goes out and **D** appears briefly in the display.

Safety cut-out

The combiset has a safety cut-out feature in case it is not turned off after use.

If the burner is heated for an unusually long period of time (see table), and the power level settings are not adjusted, the combiset will turn itself off automatically and the residual heat indicator will light.

L and **D** will flash alternately in the display.

- To use the combiset again, first turn the control knob to "0".
The On/Off indicator and the display will go out.

Power level	Maximum operating hours
1	10
2	5
3	5
4	4
5	3
6	2
7	2
8	2
9	1

Safety features

Overheating protection

The induction coils and the cooling element of the electronics are fitted with an overheating protection feature. This prevents the induction coils and cooling element from overheating.

This mechanism works in the following ways:

- If the booster function is being used, it will be switched off.
- The power level will be reduced.
- If an induction coil is affected, the burner will turn off and an **H** will appear in the display.

■ Turn the control knob to "0".

Once the **H** has gone out, the combiset can be used again as normal.

If the control knob is not turned back to "0", **E** and **D** will flash in the display. To use the burner again, first turn the control knob to "0".

- If the cooling element is affected, the power supply to the burner will be reduced.

Once the cooling element has cooled sufficiently the burner will continue working again at the original power level.

- If the temperature continues to rise after the power level has been reduced, the burner will switch off.

E and **D** will flash alternately in the display.

■ Turn the control knob to "0".

Once the burner has cooled to a safe temperature the combiset can be used again as normal.

The overheating protection feature may be activated by:

- heating an empty pan,
- oils or fats being heated on the highest power level,
- the underside of the appliance is not sufficiently ventilated.

If the overheating protection feature activates again, contact Miele Technical Service.

Do not use a steam cleaner to clean this appliance. Steam could penetrate electrical components and cause a short circuit. Pressurized steam could cause permanent damage to the surface.

Do not use any sharp pointed objects which could damage the seal between the ceramic surface, the surrounding frame and the countertop.

Never use abrasive cleaners, caustic (oven) cleaners, dishwasher detergent, scouring pads, steel wool or hard brushes. They will damage the surface.

The ceramic surface can be cleaned using a cleaner for ceramic surfaces. Follow the manufacturer's instructions.

Make sure that no cleaner residue remains on the ceramic surface by carefully wiping the combiset with a damp cloth. They may damage the combiset or produce toxic fumes when heated.

Be sure that pot and pan bases are clean and dry.

After cleaning dry the ceramic surface with a soft cloth to prevent a build up of limescale deposits. Clean any spills immediately before they become difficult to remove.

Do not use liquid dish soap to clean the ceramic surface. When using dish soap a film is left on the surface which can lead to discolorations on the ceramic surface. These discolorations cannot be removed. Clean the ceramic surface regularly with a ceramic cleaner.

Clean the appliance regularly, preferably after each use. Allow the appliance to cool before cleaning.

Cleaning and care

Ceramic surfaces

- Wipe off any soiling using a damp cloth. Stubborn soiling is best removed with a shielded scraper blade.
- Apply a ceramic cleaner (available from Miele) using a soft cloth or paper towel.
- To remove any limescale deposits or metallic residue apply a ceramic cleaner using a soft cloth or use a shielded scraper blade if necessary.
- After cleaning wipe the ceramic surface with a damp cloth and dry.

A cleaner with a special additive to prevent water marks and smears on the ceramic surface may be used.

Any melted solids like **sugar, plastic or aluminum foil** should be removed as quickly as possible, while the burner is still warm. If they are allowed to harden the combiset may become pitted.

- Turn the burner off.
- Using a shielded scraper blade, scrape the melted item **immediately** off the burner while it is still hot.
Use caution: Danger of burns!
- Allow the combiset to cool and clean as previously described.

Stainless steel

Clean stainless steel surfaces with warm water and liquid dish soap applied with a non-abrasive sponge and then wipe dry with a soft cloth. Soak baked or hardened spills first to loosen them.

Stainless steel surfaces can be cleaned using a non-abrasive stainless steel cleaner (available from Miele).

To help prevent resoiling, a conditioner for stainless steel can also be used. Apply sparingly with even pressure.

Do not use stainless steel cleaner on or around the **printing**, it may rub off. Use only a soft sponge with a mild solution of warm water and liquid dish soap to clean this area.

Frequently asked questions

 Repairs should only be carried out by an authorized technician in accordance with local and national safety regulations. Unauthorized repairs could cause injury or appliance damage.

What if the burner does not heat up after it is turned on?

Possible fault	Solution
The Child safety lock is activated.	See "Child safety lock".
The Overheating protection feature has activated.	See "Overheating protection".
The main fuse has blown.	Check the main fuse. Replace the fuse or "trip" the circuit breaker.
The demo-mode is activated. When demo mode is activated, <i>d</i> will appear in the display for a few seconds after turning the appliance on.	To de-activate, turn the control knob briefly (approx. 1 sec) to the left, two times, all the way to the stop, then turn it a third time and hold for approx. 3 seconds.

If none of the above is the case, turn the control knob to "0", and disconnect the appliance from the electrical supply for 1 minute.
Reconnect the power and turn the appliance on. If it still does not heat, contact Miele Technical Service.

What if *U* appears in the display?

Possible fault	Solution
The burner is turned on but no cookware is placed on it.	Turn the burner off and place suitable cookware on it.
The pan being used is not suitable for the combiset or is not the right size.	See "Cookware" for information on type and size of suitable cookware.

What if an *F* appears in the display?

Possible fault	Solution
The temperature sensor for the burner is faulty.	Do not use the combiset until it has been repaired. Contact Miele Technical Service.

Frequently asked questions

What if the combiset turns itself off automatically?

Possible fault	Solution
Either the "Safety cut-out" feature or the "Overheating protection" feature has been activated.	See "Overheating protection" or "Safety cut-out".

What if one of the following errors occurs:

- The booster function turns off automatically ahead of time.
- \bar{L} and \bar{D} flash alternately in the display.
- H is shown in the display.

Possible fault	Solution
The overheating protection feature has been activated.	See "Overheating protection".

The food does not cook when using the Auto-heat function.

Possible fault	Solution
Large amounts of food are being cooked.	Select a higher continued power level or begin cooking at the highest level and turn the power back by hand.
The pot or pan does not transfer the heat properly.	Use the correct pots and pans, see "Cookware".

The cooling fan continues to run after the combiset is turned off.

Possible fault	Solution
This is not a fault.	The fan continues to run until the appliance has cooled sufficiently. It will turn off automatically.

In the event of a fault which you cannot easily fix yourself, please contact the Miele Technical Service Department at the address on the back of this booklet.

When contacting Technical Service please quote the serial number and model of the appliance.

Adhere rating label sticker supplied with the appliance below.

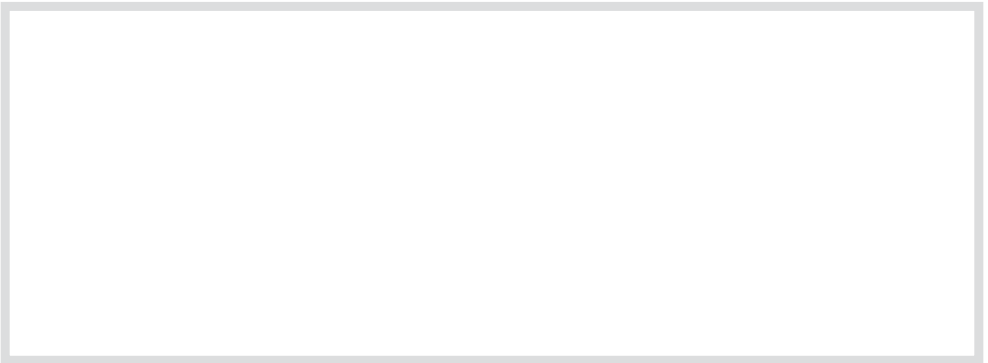

Technical Service

MieleCare

(USA only)

MieleCare, our Extended Service Contract program; gives you the assurance of knowing that your appliance investment is covered by 5 years of worry free ownership.

MieleCare is the only Extended Service Contract in the industry that guarantees repairs by a Miele Authorized Service Provider using genuine Miele parts. Only genuine Miele parts installed by factory trained professionals can guarantee the safety, reliability and longevity of your Miele appliance.

Please note that unless expressly approved in writing by the Miele Service department, Extended Service Contracts offered by other providers for Miele products will not be recognized by Miele. Our goal is to prevent unauthorized (and untrained) service personnel from working on your Miele products, possibly doing further damage to them, you and/or your home.

To learn more about **MieleCare** Extended Service Contracts, please contact your appliance dealer or visit us online at:

<http://mieleusa.com/mielecare>

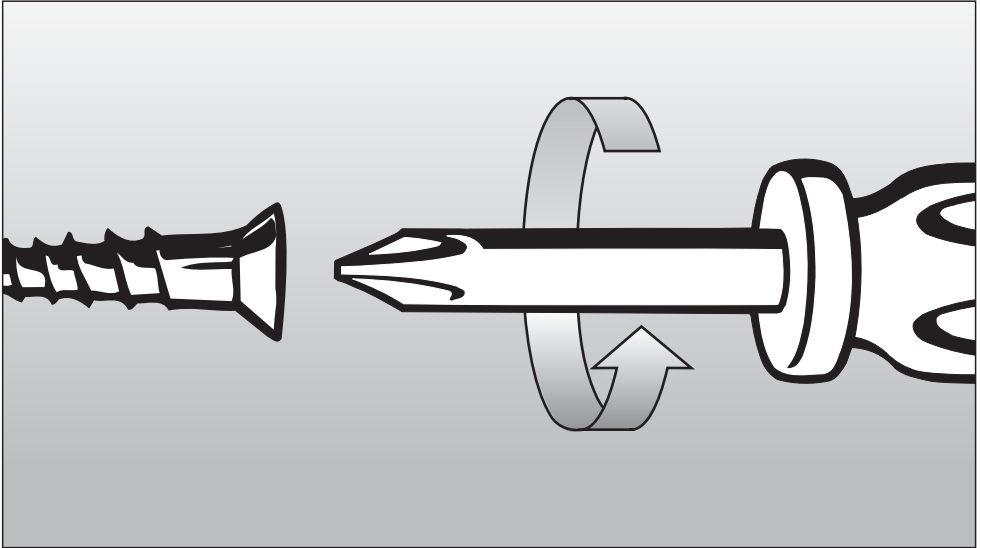

Installation Instructions

IMPORTANT: SAVE FOR THE LOCAL ELECTRICAL INSPECTOR'S USE

Information is subject to change. Please refer to our website to obtain the most current product specification, technical & warranty information.

To prevent accidents
and appliance damage
read these instructions

before
installation or use.

IMPORTANT INSTALLATION SAFETY INSTRUCTIONS

Note to the installer:

Please leave this instruction book with the consumer for the local electrical inspector's use.

The minimum distances given in these Installation Instructions must be observed in order to ensure safe operation. Failure to do so increases the risk of fire.

The cabinetry and venting hood should be installed first to prevent damage to the appliance.

- ▶ The countertop must be bonded with heat resistant (212°F/100°C) adhesive to prevent distortion or dissolving. Any back splashes must be heat-resistant as well.
- ▶ The appliance must not be installed over a dishwasher, washer, dryer, refrigerator or freezer. Heat radiated by the appliance may damage them.
- ▶ To eliminate the risk of burns or fire by reaching over heated surfaces cabinet storage space above the appliance should be avoided. If cabinet storage is necessary, the risk can be reduced by installing a venting hood to project horizontally a minimum of 5" (127 mm) beyond the bottom of the cabinets.

- ▶ This appliance must not be used in a non-stationary location (e.g. on a ship).
- ▶ You must ensure the power cord for the appliance will not be subject to any mechanical strain after installation.
- ▶ If a protective base is installed beneath the appliance, a minimum distance of 1 ⁹/₁₆" (40 mm) between the top of the protective base and the bottom of the appliance must be maintained.
- ▶ The appliance must not be permanently sealed into the countertop when installed. The sealing strip under the edge of the appliance provides a sufficient seal for the countertop. See "Sealing".

Keep this instruction book in a safe place for reference and pass it on to any future user.

IMPORTANT INSTALLATION SAFETY INSTRUCTIONS

Safety distances above the appliance

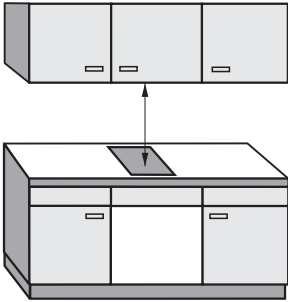

The minimum safety distance given by the hood manufacturer must be maintained between the combiset and the hood above it. See the installation instructions of the hood for these safety measurements.

If the hood manufacturers instructions are not available or if flammable objects are installed over the combiset (e.g. cabinets, utensil rail, etc.), a minimum safety distance of 30" (760 mm) must be maintained.

If there is more than one appliance beneath a hood (e.g. wok burner and electric combiset), and they have different minimum safety distances always observe the greater distance.

IMPORTANT INSTALLATION SAFETY INSTRUCTIONS

Safety distances to the sides of the appliance

The appliance should only be installed as shown in the illustrations, while maintaining the required safety distances shown. Do not install the appliance between two tall cabinets, this is a fire hazard.

A distance of at least 2" (50 mm) must be kept between the countertop cut-out and the rear wall because of the high temperatures radiated.

The minimum distance required from the countertop cut-out to the side wall ①:

2" (50 mm) for CS 1112
CS 1122
CS 1212
CS 1221
CS 1223
CS 1326
CS 1327
CS 1411

6" (150 mm) for CS 1312
CS 1322
CS 1421

10" (250 mm) for CS 1011
CS 1012
CS 1012-1
CS 1028

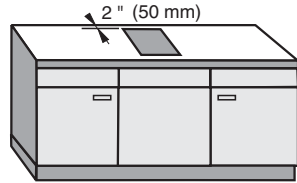
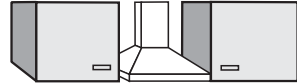

recommended

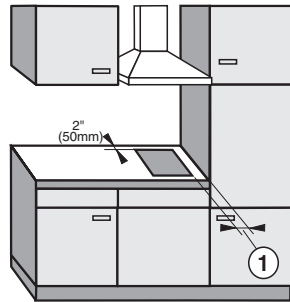

not recommended

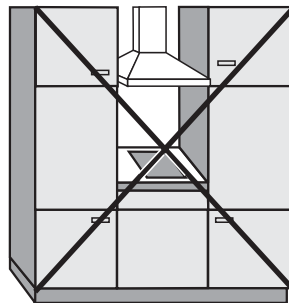

not permitted

Safety distance from the wall covering

If a wall covering is installed, a minimum safety distance must be maintained between the countertop cut-out and the covering, since high temperatures can damage these materials.

If the covering is made of a combustible material (such as wood), the distance between the countertop cut-out and the wall covering must be a minimum of 2" (50 mm).

For coverings made of non-combustible materials (such as metal, marble, granite or ceramic tiles) the minimum safety distance ⑤ between the countertop cut-out and the wall covering must be 2" (50 mm) minus the thickness of the covering.

For example: thickness of wall covering 9/16" (15 mm)

2" (50 mm) - 9/16" (15 mm) = minimum safety distance 1 3/8" (35 mm).

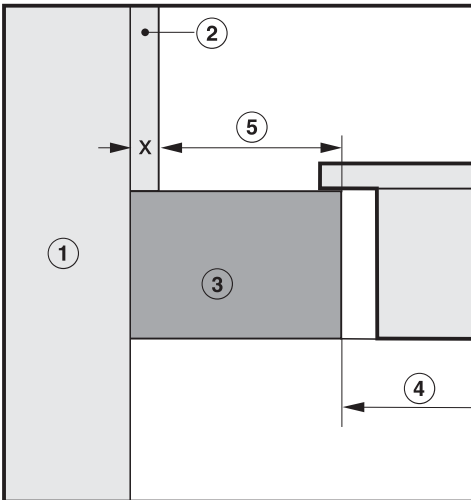

- ① Wall frame
- ② Wall covering
x = thickness of the wall covering
- ③ Countertop
- ④ Countertop cut-out
- ⑤ Minimum safety distance
with flammable materials 2" (50 mm)
with non-flammable materials 2" (50 mm) minus **x**

Installation

Installation dimensions

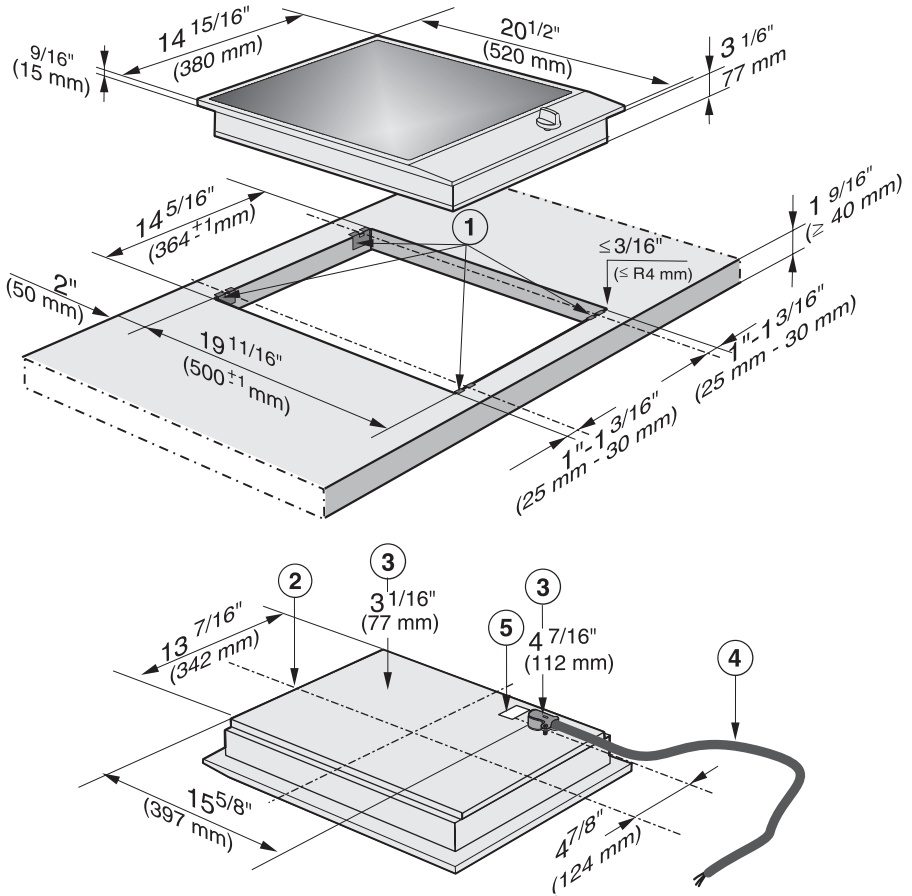

- ① Spring clips
- ② Appliance front
- ③ Installation height
- ④ Power supply box with connection cable
- ⑤ Rating label

Cut out

- Make the countertop cut-out for the desired number of appliances. Remember to maintain a **minimum safety distance** from the **back wall**, as well as from any **tall unit or side wall** to the left or right of the combiset.
See also the "IMPORTANT INSTALLATION SAFETY INSTRUCTIONS".
- Seal the cut surfaces with a suitable sealant to avoid swelling caused by moisture. The materials used must be heat resistant.

If during installation the seal around the frame does not sit flush with the countertop in the corners, the corner radius, maximum $\frac{3}{16}$ " (4 mm), can be carefully filed down to fit.

Installation

Installation of multiple appliances

When installing more than one combiset appliance, a support bar ② must be installed between the appliances.

Countertop cut-out two appliances

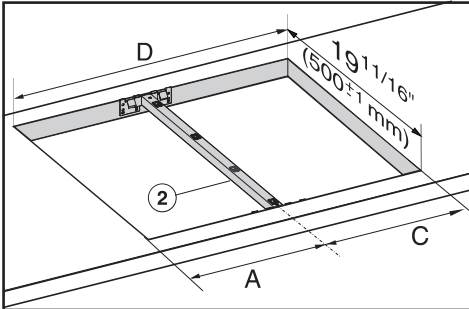

For the installation of **two appliances** the width of the countertop cut-out D is the sum of A and C.

A, B and C = appliance width
11 5/16", 15" or 22 11/16"
(288 mm, 380 mm or 576 mm)
minus 5/16" (8 mm) to allow for the overhang

D = width of the countertop cut-out

Countertop cut-out three appliances

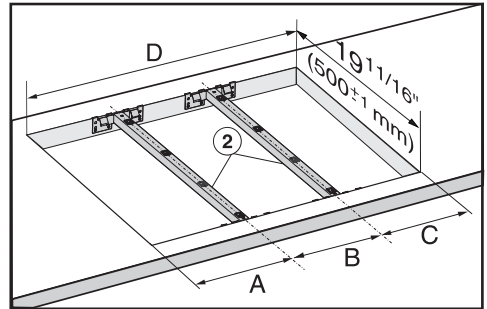

For the installation of **three appliances** the width of the countertop cut-out D is the sum of A and B and C.

If **more than three appliances** are being installed, you will need to add, A, B or C for each additional appliance.

Sample calculations for a countertop cut-out for three appliances

A appliance width minus 5/16" (8 mm)	B appliance width	C appliance width minus 5/16" (8 mm)	D Countertop cut-out
11" (280 mm)	11 5/16" (288 mm)	11" (280 mm)	33 3/8" (848 mm)
11" (280 mm)	15" (380 mm)	14 5/8" (372 mm)	40 5/8" (1032 mm)
11" (280 mm)	22 11/16" (576 mm)	22 3/8" (568 mm)	56 1/16" (1424 mm)
14 5/8" (372 mm)	11 5/16" (288 mm)	11" (280 mm)	37" (940 mm)
14 5/8" (372 mm)	15" (380 mm)	14 5/8" (372 mm)	44 1/4" (1124 mm)
14 5/8" (372 mm)	22 11/16" (576 mm)	22 3/8" (568 mm)	59 11/16" (1516 mm)
22 3/8" (568 mm)	11 5/16" (288 mm)	11" (280 mm)	44 3/4" (1136 mm)
22 3/8" (568 mm)	15" (380 mm)	14 5/8" (372 mm)	52" (1320 mm)
22 3/8" (568 mm)	-	22 3/8" (568 mm)	44 3/4" (1136 mm)

Installation

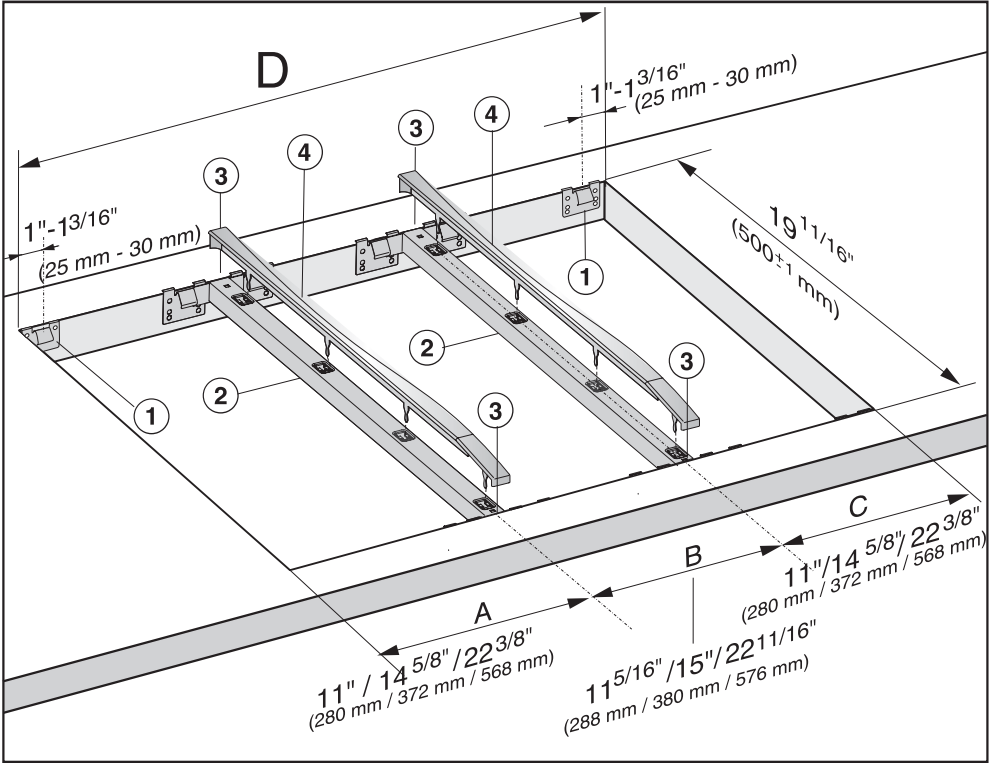

- ① Spring clips
- ② Support bars
- ③ Space between support bar and countertop
- ④ Cover

The illustration represents the attachment of spring clips ① and support bars ② for 3 appliances.

An additional support bar is required for each additional appliance. The position for attachment of an additional support bar depends on the width of appliance **B**.

Attach the spring clips and support bars

Wood or solid surface countertops

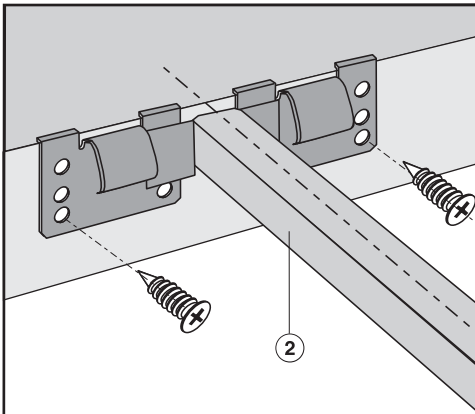
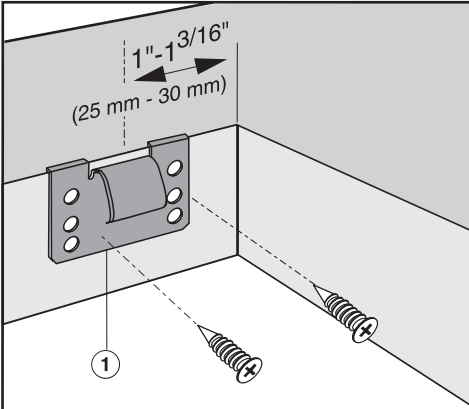

- Place the supplied spring clips ① and the support bars ② at the marked positions as shown above, by laying them on the upper edge of the cut-out and then securing them with the $\frac{1}{8}'' \times 1''$ (3.5 x 25 mm) screws (supplied).

Installation

Granite countertop

The screws are not needed for granite countertops.

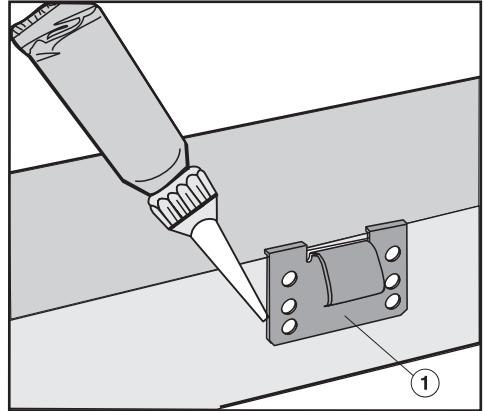
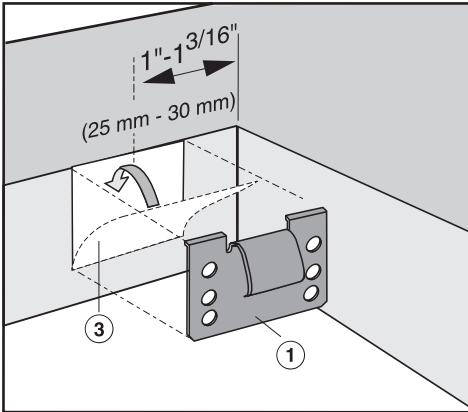

- Coat the side and lower edges of the spring clips between ① and ② with silicone.

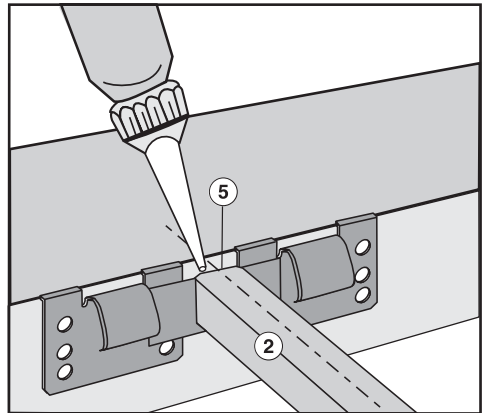
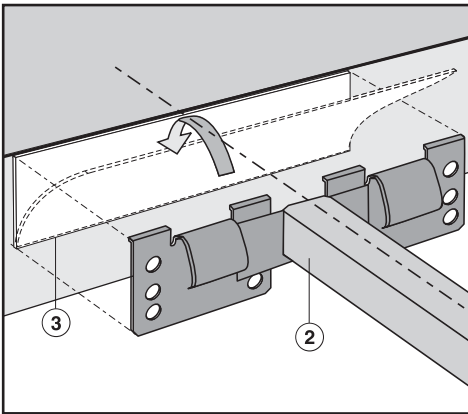

- Position and attach the spring clips ① and support bars ② with strong, double-sided tape ③.

- Fill the space ⑤ between the support bars ② and the countertop with silicone.

Installing the appliance(s)

- Feed the power cord down through the cut-out.
- Place the front edge of the appliance into the cut-out.
- With a hand on each side of the appliance press down evenly on the edges until it clicks into position. When doing so make sure that the appliance seal sits tightly on the countertop to ensure it is sealed correctly. This is important to ensure an effective seal. **Do not** permanently seal into the countertop.
- Push the installed appliance to the side until the holes in the support bar are visible.

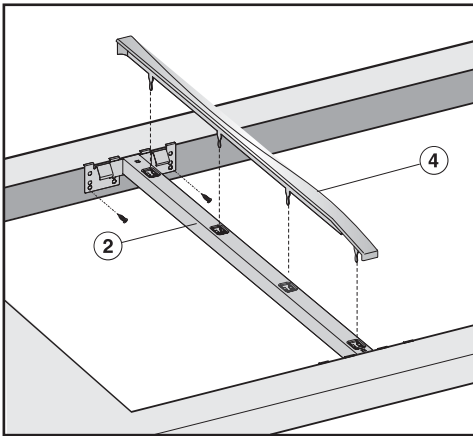

- Insert the cover ④ into the holes in the support bar ②.

- Place the front edge of the next appliance into the cut-out.
- Connect the appliance(s) to the main power supply (see "Electrical connection").
- Turn the appliance(s) on and check the function.

The appliance may be lifted out using a special tool.
The appliance can also be pushed up and out from underneath.
Note: push the rear out first.

Installation

Sealing

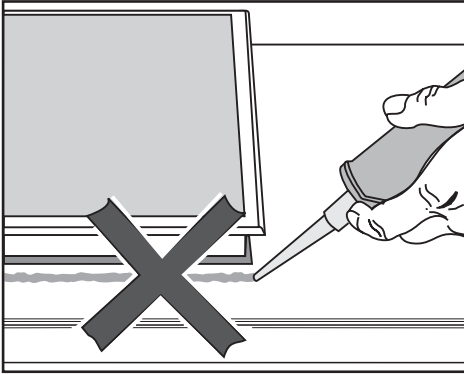

The appliance **must not** be permanently sealed into the countertop when installed. The sealing strip under the edge of the appliance provides a sufficient seal for the countertop.

If the appliance is sealed into position, the countertop or appliance could be damaged if it needs to be removed for maintenance or service.

Tiled surfaces

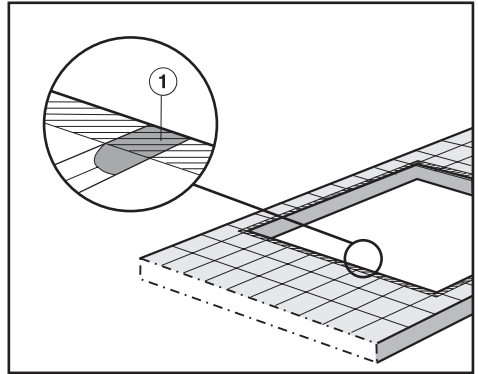

The grouting ① and shaded area under the appliance frame must be flat and even so that the frame will lie evenly and the sealing strip under the edge of the upper part of the appliance can provide an adequate seal against the countertop.

 **CAUTION:** Before installation or servicing, disconnect the power supply by either removing the fuse, shutting off the main power or manually "tripping" the circuit breaker.

Installation work and repairs should only be performed by a qualified technician in accordance with all applicable codes and standards. Repairs and service by unqualified persons could be dangerous.

Before connecting the appliance to the power supply, make sure that the voltage and frequency listed on the rating label correspond with the household electrical supply. This data must correspond to prevent appliance damage. Consult an electrician if in doubt.

Only operate the appliance after it has been installed into the countertop.

Installer:
Please leave these instructions with the consumer.

Power supply

- Be sure your electrical supply matches the rating label.

The rating label is located on the underside of the appliance.

The combiset is equipped with a power cord encasing 3 wires ready for connection to a grounded power supply.

They must be connected to a dedicated line through the use of an approved junction box.

Black : connect to L1 (hot)

Red: connect to L2 (hot)

Green: connect to GND (ground):

208 - 240 V, 60 Hz, 20 A fuse rating

Be sure the power outlet is accessible after installation.

For further information, see the wiring diagram provided with the appliance.

 **WARNING:**
THIS APPLIANCE MUST BE GROUNDED!

Help protect our environment

Disposal of packing materials

The cardboard box and packing materials are biodegradable and recyclable. Please recycle.

Ensure that any plastic wrappings, bags, etc. are disposed of safely and kept out of the reach of children.

Danger of suffocation!

Disposal of an old appliance

Old appliances contain materials that can be recycled. Please contact your local recycling authority about the possibility of recycling these materials.

Before discarding an old appliance disconnect it from the electrical supply and cut off the power cord to prevent it from becoming a hazard.

**Please have the model and serial number
of your appliance available before
contacting Technical Service.**



U.S.A. Miele, Inc.

National Headquarters

9 Independence Way
Princeton, NJ 08540
Phone: 800-843-7231
609-419-9898
Fax: 609-419-4298
www.mieleusa.com

Technical Service & Support Nationwide

Phone: 800-999-1360
Fax: 888-586-8056

TechnicalService@mieleusa.com

Canada Miele Limited

Headquarters and Showroom

161 Four Valley Drive
Vaughan, ON L4K 4V8
Phone: 800-643-5381
905-660-9936
Fax: 905-532-2290
www.miele.ca
professional@miele.ca
(commercial enquiries)

MieleCare National Service

Phone: 800-565-6435
905-532-2272
Fax: 905-532-2292
customercare@miele.ca
(general and technical enquiries)

Germany

Miele & Cie. KG
Carl-Miele-Straße 29
33332 Gütersloh