



FULL LINE CATALOGUE



Smalterie Metallurgiche Emiliane Guastalla
Metal Enameling Factory based in Guastalla

THE SMEG PHILOSOPHY

Distinctive domestic appliances born from a collaboration with the leading architects of the world.

Products that express "Made in Italy" style by perfectly combining design, performance, and attention to detail.
SMEG: Technology with Style.



MADE IN ITALY
PREMIUM QUALITY AND DESIGN

Contents

10

Ranges



42

Hoods



98

Cooktops



110

Refrigerators



132

Dishwashers



56

Ovens



72

Compact Ovens and
Coffee Machines



92

Wine Coolers



142

Sicily is my Love
Collection



148

Small Domestic
Appliances



173

Technical Drawings

- 1948** Vittorio Bertazzoni Sr founds SMEG (Smalterie Metallurgiche Emiliane Guastalla) in Guastalla, near Reggio Emilia in Italy.
- 1955** Production of ranges begins, reaching its peak with the presentation of the first SMEG brand range, Elisabeth, in 1956.
- 1963** The company presents Leda, the first SMEG-branded washing machine, thanks to an increase in production capacity to include laundry appliances.
- 1970** Niagara is released, the world's first 14-place setting dishwasher, meeting modern requirements for large wash capacities.
- 1971** Production of built-in appliances such as ovens and cooktops begins; these products will become part of the defining elements of SMEG's success.
- 1977** Franco Maria Ricci, one of Italy's most illustrious publishers and graphic designers, creates the SMEG logo which incorporates references to the burners of a gas cooktop and the round knobs of an oven. SMEG also begins its sponsorship of legendary Ferrari driver Gilles Villeneuve.
- 1985** Instinctively and incisively understanding new consumer requirements for more-elegant products, the company begins working with architect Guido Canali to create ovens and cooktops.
- 1991** SMEG's collaboration with important designers continues, with the company offering ovens and cooktops designed by architect Mario Bellini.
- 1995** The company begins working with architect Renzo Piano, a collaboration which will lead to the production of cooktops, ovens, fridges and the SMEG home garden.
- 1997** The FAB assortment of fridges is created, a product line destined to become an international style icon and status symbol.
- 2002** Guido Canali designs the SMEG Headquarters, for which he receives an honorable mention at the Milan Triennale's "Medaglia d'Oro all'Architettura Italiana" architectural awards in 2006.
- 2008** SMEG celebrates its 60th anniversary and presents products designed alongside Marc Newson, which leads to winning the Wallpaper Design Award the following year.
- 2010** SMEG receives the Good Design Award for an oven and cooktop from the Linea Aesthetic Line. The same prestigious recognition will also be assigned in 2012 and 2013 for other products in the range.
- 2012** The first denim-covered fridge, created in collaboration with Italia Independent, is released, followed by the SMEG500, a cooler designed with the appearance of a Fiat 500 car.
- 2014** The '50s Style small appliances line, created together with the deepdesign© studio, makes its debut and immediately wins over both customers and critics. SMEG wins the Good Design award once again, as well as the iF Design Award, and Red Dot Design Award.
- 2016** A collaboration between SMEG and Dolce&Gabbana creates the mesmerising 'Frigorifero of Art': a special edition of 100 FAB28s hand-painted by Sicilian artists. Portofino ranges are also introduced in North America.

HISTORY

SMEG has been producing domestic appliances with the finest Italian designs for more than 70 years, with a particular focus on aesthetics, ergonomics, and functionality.

Today, SMEG, an acronym for “Smalterie Metallurgiche Emiliane Guastalla”, indicating the company's foundation in enamel work and metallurgy, has reached its third generation family ownership, and represents an international group with direct subsidiaries and distributors on five continents.

THE SMEG HEADQUARTERS DESIGNED BY ARCHITECT GUIDO CANALI

EXHIBITED AT THE 13TH VENICE ARCHITECTURE BIENNIAL IN 2012. IT WAS SHOWN IN THE ITALIAN PAVILION AS AN ARCHITECTURAL EXAMPLE OF EXCELLENCE MADE IN ITALY, A STRUCTURE IN TUNE WITH THE CULTURE OF THE REGION, THE LIFE OF THE PEOPLE, AND ENVIRONMENTAL SUSTAINABILITY.



SMEG BELIEVES THAT OBJECTS OF DAILY USE SHOULD NOT ONLY FILL AN ENVIRONMENT; THEY SHOULD CREATE AN ATMOSPHERE. THIS SENSITIVITY, WHICH HAS INSPIRED A COLLABORATION WITH GREAT ARCHITECTS AND DESIGNERS OF OUR TIME, IS THE PERFECT EXPRESSION OF THE MADE IN ITALY PHILOSOPHY, WHICH COMBINES ART AND INDUSTRIAL EXPERTISE IN EVERYDAY OBJECTS.



SMEG PRODUCTS

SMEG products, the perfect combination of refined aesthetics and technological reliability, have transformed simple kitchen appliances into designer furnishings, undisputed examples of the finest Italian design: a range of fully-coordinated domestic appliances with unmistakably-refined aesthetics and a well-defined identity of its own.

RANGES

SMEG's philosophy, "Technology with Style", fully emerges in its truly versatile series of pro ranges. SMEG's acclaimed pro ranges reflect the artistry and techniques of the passionate cook by offering a wealth of functions and features.



CPF48UGWH

VERSATILITY

an ample range of style and dimensions

SMEG ranges are icons of design, combining classic SMEG style with outstanding performance. Inspired by the ranges favored by the world's great chefs, SMEG offers products where style and elegance meet versatility for people who genuinely love to cook.



PORTOFINO



OPERA



PROFESSIONAL STYLE



VICTORIA

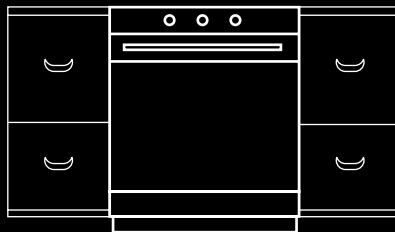

BUILDING-IN SOLUTION

SMEG ranges can be elegantly slotted in-between kitchen furniture for a distinctive look that is totally safe, thanks to the excellent, insulation and outercooling system that prevents the sides of SMEG pro ranges from overheating.

MULTIPLE CONVECTION FANS

Many SMEG ranges have two convection fans that ensure uniform heat distribution, and allow you to cook large meals with ease.

AIR COOLING SYSTEM

The forced air recirculation system means that the sides, door and components inside the oven, remain cool, ensuring greater safety, and a longer life for the appliance.

VICTORIA RANGE

powerful traditional style

A passion for cooking deserves an outstanding tool to realize that passion, one that perfectly blends functionality with style.



EXTRA VOLUME

SMEG produces ovens with a wider cavity. 36" wide ranges have a net volume of 4.4 cu ft, which allows the use of wide baking trays.

TWO FANS

Many ranges with electric ovens have two fans that ensure uniform heat distribution, and allow you to cook large meals.

AIR COOLING SYSTEM

The forced fresh air recirculation system means that the sides, the door, and the components inside the range remain cool, ensuring greater safety, and a longer life for your appliance. The cooling system remains in-operation even when cooking is finished, continuing to function with the oven switched-off, so as to dissipate the heat that has accumulated inside the range.

EVERCLEAN ENAMEL

The specially-coated EverClean enamel prevents grease from adhering to the oven walls, to reduce cleaning time and effort.

FULL-LENGTH STORAGE DRAWER

Convenient space for kitchen utensils and oven accessories.



PORTOFINO RANGE

a charismatic identity

The kitchen is one of the most extensively-used environments in the house, where people come together to dine and share a space throughout the day. The technological developments introduced by SMEG serve to simplify everyday tasks. The company strives to understand and anticipate the needs of its users, who are demonstrating increasing interest in taking full advantage of the kitchen space.



Available in three different dimensions from 30 inches wide to 48 inches, SMEG Portofino ranges satisfy every space requirement.

Range ovens have different capacities, from 1.45 cu ft capacity to an ample 4.5 cu ft.

DUAL ULTRARAPID BURNER

The dual ultrarapid burner consists of a double crown, which combines an ultrarapid burner with an auxiliary burner reaching a maximum of 20,000 BTUs.

The burners are uniquely designed with different flame arrangements, and offer superior performance. From the smallest to the most powerful ultrarapid burner, the Portofino range can be used for a host of applications.

FULL-WIDTH GRATE

The gas cooktops are equipped with solid, heavy-duty cast-iron grates, covering the complete surface of the range. This extends the support surface to a maximum, providing an aesthetic, functional solution, which is perfectly aligned with the countertop, as well as sitting flush with other modular units to create a streamlined effect. This linear and ergonomic design helps provide the range with both a professional look, and a professional approach to cooking.



PORTOFINO RANGE

boundless italian style

This colorful range, inspired by the rich tones of the Mediterranean, offers superb performance, and is characterized by the clean lines typical of professional kitchen design. The new PORTOFINO range is available in 8 different colors and 2 different configurations, all-gas and dual-fuel.

TRIPLE-FAN TECHNOLOGY

The oven is equipped with an exclusive three fan system, which, combined with the increased power of the motors, enables excellent cooking performance.

The two large side fans distribute the air around the outer perimeter of the cavity while the smaller central fan increases ventilation by creating a vertical vortex of heat. Accordingly, the temperature within the cavity is uniform, allowing food to be cooked evenly on all five levels, like in professional kitchens.

ISOTHERMIC-PROOF CAVITY

This new cavity is characterized by its unique shape, with rounded corners and smooth, uniform walls, for maximum thermal insulation and optimal energy performance.

The perfect insulation of the cavity also helps reduce pre-heating time. The multifunction version, for example, reaches a temperature of 392°F in just 6 minutes, a time saving of 50% compared to a standard oven.

5 COOKING LEVELS

The different cooking levels enable maximum flexibility of use, and allow different courses to be cooked simultaneously. This enables users to optimize the time spent cooking, preparing multiple courses quickly and efficiently while preserving distinctive flavors.

COOKING ON STONE

Portofino ovens can be equipped with a large refractory stone for quick and easy baking, which is ideal for cooking healthy homemade pizza and bread, as well as fish and vegetables.

By activating the Turbo function, you can cook two pizzas simultaneously, in just 4 minutes.

SOFT CLOSE

The oven door is equipped with a Soft Close system which closes the door in a silent, soft motion, with no need to push it.



PRO-STYLE RANGE GAS OVEN SERIES

for foodies who love to bake and roast

Ideal for baking and roasting most types of food, the flame on a gas stovetop lights immediately, giving you instant heat, and you can control the heat level with precision. When you turn the flame off, the food can stay on the range without worry of overcooking because the elements cool rapidly. The C-Series are available in sizes from 24" to 36".

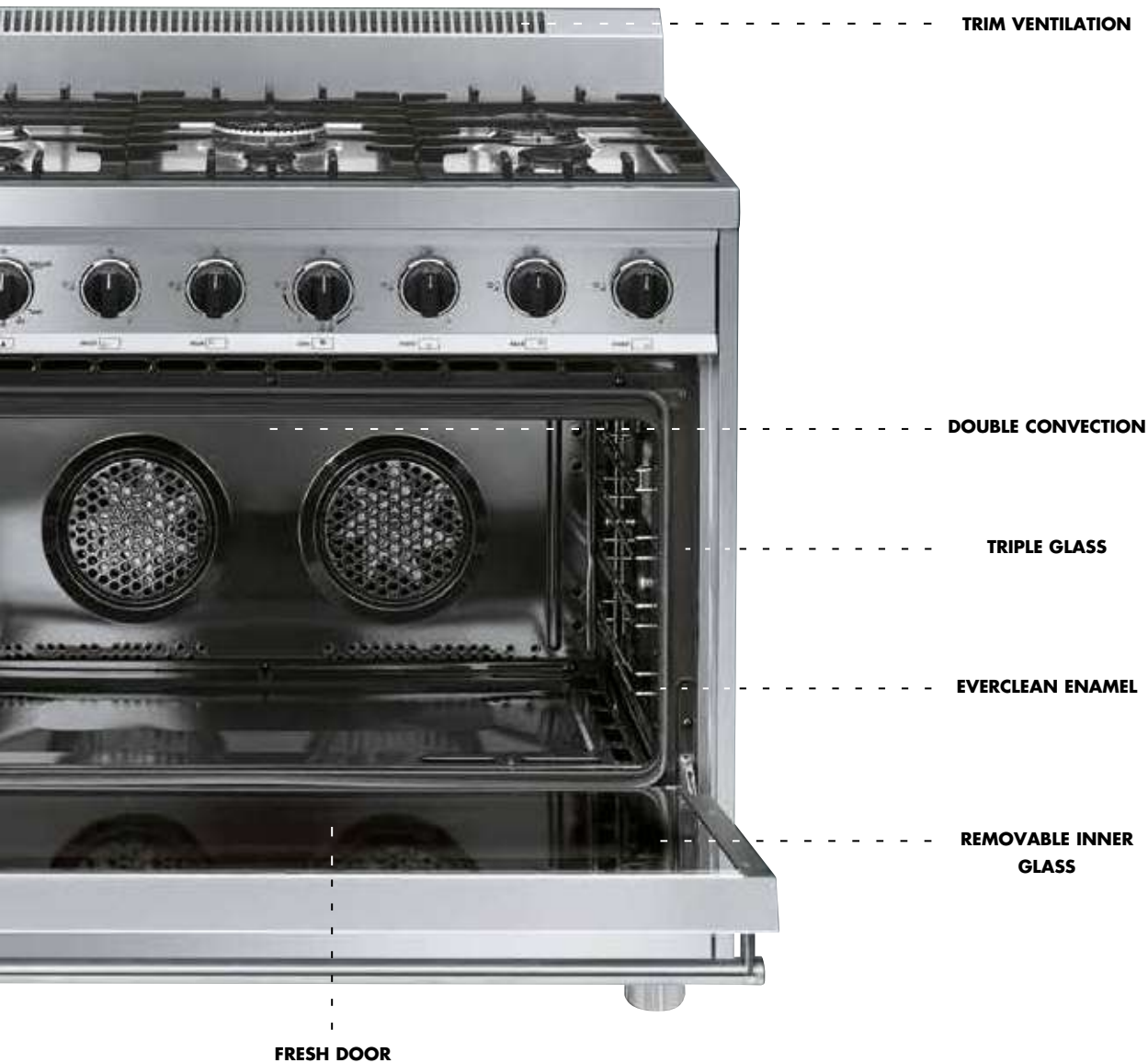

OPERA

timeless elegance

SMEG ranges are icons of design, combining classic SMEG style with outstanding performance. Inspired by the ranges favored by the world's great chefs, SMEG offers products where style and elegance meet versatility for people who genuinely love to cook.

SUPER BURNER

Central double-inset super burner 15,000 BTU.

TRIM for ventilation.

ELLIPTICAL BURNER for irregular cookware.



ANTI-OVERFLOW COOKTOP

This feature avoids spills of liquid, thus protecting the kitchen furniture on either side.

CAST-IRON PAN STANDS

Strong cast-iron grates and matte black burner caps.

STORAGE STEEL DRAWER

Full-width stainless steel drawer ensures that all of your useful cooking accessories are within arm's reach.

ELECTRIC BARBECUE-GRILL

For convenient indoor grilling.

CPF48UGMX

PORTOFINO PRO-STYLE DUAL-FUEL RANGE, STAINLESS STEEL, 48" X 25"



CPF48UGMR
Red



CPF48UGMYW
Yellow



CPF48UGMWH
White



CPF48UGMOR
Orange



CPF48UGMBL
Black



CPF48UGMOG
Olive Green



CPF48UGMX
Stainless Steel



CPF48UGMAN
Matte Black

Portofino Style

- Stainless steel control knobs
- Thermoseal cavity, energy efficiency best-in-class
- Soft Close oven door
- Full-width continuous grates
- Storage compartment with inner drawer

MULTIFUNCTION ELECTRIC OVEN - MAIN:

10 cooking modes, including Pizza Function



- Vapor-Clean function
- Programmable timer with touch display
- Adjustable thermostat 120° - 500° F
- Air-cooled triple-glazed removable door
- True European triple convection
- Oven capacity: 4.5 cu ft
- EverClean enameled interior cavity
- 5 shelf positions
- 2 halogen oven lights
- Bake element 1.7 kW
- Broil element 2.9 kW
- Convection element 1.5 kW

MULTIFUNCTION ELECTRIC OVEN - SECONDARY:

4 cooking modes



- True European convection
- Adjustable thermostat 120° - 440° F
- EverClean enameled oven interior
- Air-cooled triple-glazed removable door
- Removable inner glass for easy cleaning
- Oven capacity: 1.45 cu ft
- 5 shelf positions
- 2 x halogen oven lights
- Bake element 750 W
- Broil element 2.05 kW
- Convection element 1.5 kW

GAS RANGETOP:

- 5 gas burners with Electric Griddle
- Center-rear: 12,000 BTUs
- Center-front: 4,500 BTUs
- Right-rear: 12,000 BTUs
- Right-front: 8,000 BTUs
- Left double-inset super burner: 20,000 BTUs
- Heavy-duty cast-iron grates
- Automatic electric ignition
- LP gas conversion kit included

SAFETY:

- Gas safety valves
- Air-cooled door to prevent overheating

Connected load nominal power: 240/120V - 17 Amps
Voltage rating: 240/120V 60Hz

ACCESSORIES INCLUDED:

- 1 wok ring
- 1 rotisserie kit
- 1 deep oven tray
- 1 total-extraction telescopic guide
- 2 chrome shelves
- 1 black toe kick

OPTIONS:

- BGTR9 Grill plate
- TPKTR9 Teppanyaki grill plate
- GT1T-2 1-level telescopic shelf - total extraction
- PPR9 Pizza stone
- BGTR4110 Cast-iron grill plate

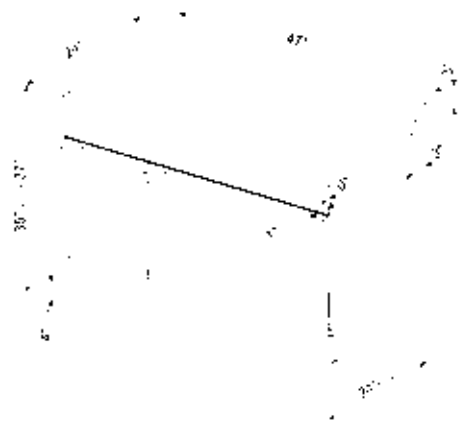

For technical drawing in metric, see page 174



CPF36UGMWH

PORTOFINO PRO-STYLE DUAL-FUEL RANGE, WHITE, 36" X 25"



CPF36UGMR
Red



CPF36UGMYW
Yellow



CPF36UGMWH
White



CPF36UGMOR
Orange



CPF36UGMBL
Black



CPF36UGMOG
Olive Green



CPF36UGMX
Stainless Steel



CPF36UGMAN
Matte Black

Portofino Style

- Stainless steel control knobs
- Thermoseal cavity, energy efficiency best-in-class
- Soft Close oven door
- Full-width continuous grates
- Push-pull stainless steel storage compartment

MULTIFUNCTION ELECTRIC OVEN:

10 cooking modes including Pizza Function



- Vapor-Clean function
- Programmable timer with touch display
- Adjustable thermostat 120° - 500° F
- Air-cooled triple-glazed removable door
- True European triple convection**
- Oven capacity: 4.5 cu ft
- EverClean enameled interior cavity**
- 5 shelf positions
- 2 halogen oven lights
- Bake element 1.7 kW
- Broil element 2.9 kW
- Convection element 1.5 kW

GAS RANGETOP:

- 5 gas burners
- Center-rear: 4,500 BTUs
- Center-front: 10,500 BTUs
- Right-rear: 12,000 BTUs
- Right-front: 8,000 BTUs
- Left double-inset super burner: 20,000 BTUs**
- Heavy-duty cast-iron grates
- Automatic electric ignition
- LP gas conversion kit included

SAFETY:

- Gas safety valves
- Air-cooled door to prevent overheating

Connected load nominal power: 240/120V - 17 Amps
Voltage rating: 240/120V 60Hz

ACCESSORIES INCLUDED:

- 1 wok ring
- 1 rotisserie kit
- 1 deep oven tray
- 1 total-extraction telescopic guide
- 2 chrome shelves
- 1 black toe kick

OPTIONS:

- BGTR9 Cast-iron grill plate
- TPKTR9 Teppanyaki grill plate
- GT1T-2 1-level telescopic shelf - total extraction
- PPR9 Pizza stone

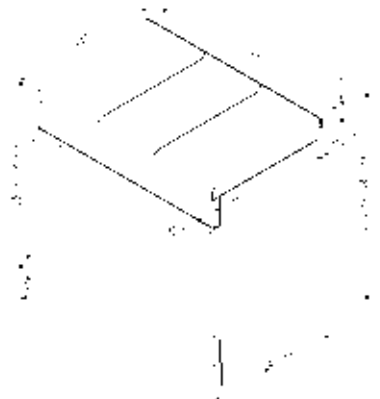

For technical drawing in metric, see page 174



KPF36UYW hood with backsplash
and CPF36UGMYW range

CPF36UGGR

PORTOFINO PRO-STYLE ALL-GAS RANGE, RED, 36" X 25"



CPF36UGGR
Red



CPF36UGGYW
Yellow



CPF36UGGWH
White



CPF36UGGOR
Orange



CPF36UGGBL
Black



CPF36UGGOG
Olive Green



CPF36UGGX
Stainless Steel



CPF36UGGAN
Matte Black

Portofino Style

Stainless steel control knobs

Triple Convection

Soft Close oven door

Full-width continuous grates

Push-pull stainless steel storage compartment

GAS OVEN:

4 cooking modes

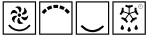

Programmable timer with touch display

Adjustable thermostat 120° - 500° F

Air-cooled triple-glazed removable door

Triple Convection

Oven capacity: 4.5 cu ft

EverClean enameled interior cavity

5 shelf positions

2 halogen oven lights

GAS RANGETOP:

5 gas burners

Center-rear: 4,500 BTUs

Center-front: 10,500 BTUs

Right-rear: 12,000 BTUs

Right-front: 8,000 BTUs

Left double-inset super burner: 20,000 BTUs

Heavy-duty cast-iron grates

Automatic electric ignition

LP gas conversion kit included

SAFETY:

Gas safety valves

Air-cooled door to prevent overheating

Connected load nominal power: 200W - 2 Amps

Voltage rating: 120V 60Hz

ACCESSORIES INCLUDED:

1 wok ring

1 deep oven tray

1 total-extraction telescopic guide

2 chrome shelves

1 black toe kick

OPTIONS:

BGTR9 Grill plate

BGTTR9 Cast-iron grill plate

TPKTR9 Teppanyaki grill plate

GT1T-2 1-level telescopic shelf - total extraction

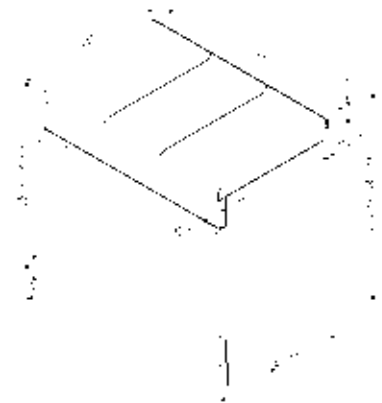

For technical drawing in metric, see page 174



Smeg

CPF30UGMBL

PORTOFINO PRO-STYLE DUAL-FUEL RANGE, BLACK, 30" X 25"



CPF30UGMR
Red



CPF30UGMYW
Yellow



CPF30UGMWH
White



CPF30UGMOR
Orange



CPF30UGMBL
Black



CPF30UGMOG
Olive Green



CPF30UGMX
Stainless Steel



CPF30UGMAN
Matte Black

Portofino Style

Stainless steel control knobs

Soft Close oven door

Full-width continuous grates

Storage compartment

MULTIFUNCTION ELECTRIC OVEN:

10 cooking modes including Pizza Function



Programmable timer with touch display

Adjustable thermostat 120° - 500° F

Air-cooled triple-glazed removable door

True European triple convection

Oven capacity: 3.6 cu ft

Ever-Clean enameled interior cavity

4 shelf positions

2 halogen oven lights

Bake element 1.7 kW

Broil element 2.9 kW

Convection element 2.7 kW

GAS RANGETOP:

4 gas burners

Diamond configuration burner layout

Center-rear: 4,500 BTUs

Center-front: 8,000 BTUs

Right super burner: 20,000 BTUs

Left double-inset super burner: 20,000 BTUs

Heavy-duty cast-iron grates

Automatic electric ignition

LP gas conversion kit included

SAFETY:

Gas safety valves

Air-cooled door to prevent overheating

Connected load nominal power: 240/120V - 17 Amps

Voltage rating: 240/120V 60Hz

ACCESSORIES INCLUDED:

1 wok ring

1 deep oven tray

1 partial-extraction telescopic guide

2 chrome shelves

1 black toe kick

OPTIONS:

BGTR9 Grill plate

BGCPF30 Cast-iron grill plate

TPKCPF30 Teppanyaki grill plate

GT91P Level telescopic shelf - partial extraction

PPR9 Pizza stone

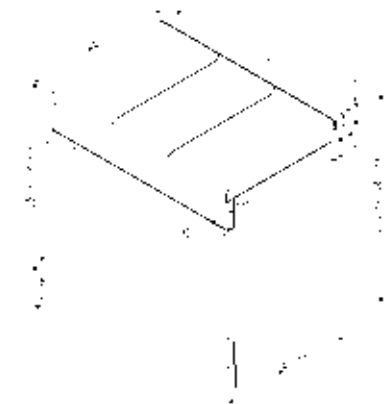

For technical drawing in metric, see page 174



CPF30UGGOG

PORTOFINO PRO-STYLE ALL-GAS RANGE, OLIVE GREEN, 30" X 25"



CPF30UGGR
Red



CPF30UGGYW
Yellow



CPF30UGGWH
White



CPF30UGGOR
Orange



CPF30UGGBL
Black



CPF30UGGOG
Olive Green



CPF30UGGX
Stainless Steel



CPF30UGGAN
Matte Black

Portofino Style

Stainless steel control knobs

Soft Close oven door

Full-width continuous grates

Storage compartment

GAS OVEN:

3 cooking modes



Programmable timer with touch display

Adjustable thermostat 120° - 500° F

Air-cooled triple-glazed removable door

Removable inner glass for easy cleaning

Oven capacity: 3.6 cu ft

EverClean enameled interior cavity

4 shelf positions

2 halogen oven lights

GAS RANGETOP:

4 gas burners

Diamond configuration burner layout

Center-rear: 4,500 BTUs

Center-front: 8,000 BTUs

Right super burner: 20,000 BTUs

Left double-inset super burner: 20,000 BTUs

Heavy-duty cast-iron grates

Automatic electric ignition

LP gas conversion kit included

SAFETY:

Gas safety valves

Air-cooled door to prevent overheating

Connected load nominal power: 200W - 2 Amps

Voltage rating: 120V 60Hz

ACCESSORIES INCLUDED:

1 wok ring

1 deep oven tray

1 partial-extraction telescopic guide

2 chrome shelves

1 black toe kick

OPTIONS:

BGTR9 Grill plate

TPKCPF30 Teppanyaki grill plate

GT91P 1-level telescopic shelf - partial extraction

BGCPF30 Cast-iron grill plate

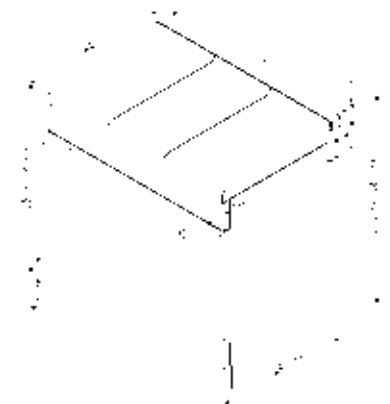

For technical drawing in metric, see page 174



smeg

A3XU7

FREE-STANDING DUAL-FUEL DUAL-CAVITY "OPERA" RANGE,
APPROX. 48", STAINLESS STEEL,
GAS RANGETOP WITH ELECTRIC GRILL



Professional Style

Stainless steel
Programmable timer with touch display
Full-width continuous grates
Storage drawer beneath the ovens
Smart-Black glass
2" stainless steel backsplash

MULTIFUNCTION ELECTRIC OVEN - MAIN:

8 cooking modes



Programmable timer with touch display
Adjustable thermostat 120° - 480° F
Triple-glazed removable door
Oven capacity: 3.2 cu ft
EverClean enameled oven interior
Roof liner
Bake element 2.8 kW
Broil element 3.85 kW
Convection element 2.5 kW

MULTIFUNCTION ELECTRIC OVEN - SECONDARY:

4 cooking modes



Programmable timer
Adjustable thermostat 120° - 430° F
EverClean enameled oven interior
Triple-glazed removable door
Oven capacity: 1.48 cu ft
Bake element 1.4 kW
Broil element 2.05 kW

GAS RANGETOP:

5 gas burners
Right-front: 3,500 BTUs
Right-rear (fish burner) 6,650 BTUs
Non-stick Teflon-coated electric grill: 5,500 BTUs
Center-front: 6,500 BTUs
Center-rear: 13,650 BTUs
Left double-inset super burner: 15,000 BTUs

Cast-iron grates and matte black burner caps
Automatic electronic ignition
LP gas conversion kit included
Easy access for nozzle replacement
Deep rangetop base to contain spillage

SAFETY

Gas safety valves
Ventilated door with cooling system to prevent overheating

Connected load nominal power: 120/240V – 6.5 kW/5 kW
Amp supply required 240/208V: 27/24 Amps
Voltage rating: 240/208V 60Hz
Gas inlet location: back top-right

ACCESSORIES INCLUDED:

2 baking trays
1 wire rack
2 rotisserie kit
1 wok ring

OPTIONS:

KIT1A3-6 Backsplash
KIT2A3XU7 Kick plate
GTA-6 3-Level telescopic shelf set
GO120 Cast-iron open griddle
DICAR Simmer plate



For technical drawing in metric, see page 174



TRU36GMWH

FREE-STANDING DUAL-FUEL CAVITY "VICTORIA" RANGE, 36" X 25", WHITE



Traditional Style

Thermoseal cavity, energy efficiency best-in-class

Soft Close oven door

Full-width continuous grates

Stainless steel storage drawer beneath the oven

MULTIFUNCTION ELECTRIC OVEN:

8 cooking modes



Programmable timer with touch display

Adjustable thermostat 120° - 500° F

Air-cooled triple-glazed removable door

True European Double Convection

Oven capacity: 4.5 cu ft

EverClean enameled interior cavity

5 shelf positions

2 halogen oven lights

Bake element 1.7 kW

Broil element 2.9 kW

Convection element 1.5 kW

GAS RANGETOP:

5 gas burners

Right-rear: 8,000 BTUs

Left-rear: 8,000 BTUs

Central double-inset super burner: 20,000 BTUs

Right-front: 4,500 BTUs

Left-front: 12,000 BTUs

Heavy-duty cast-iron grates

Automatic electric ignition

LP gas conversion kit included

SAFETY:

Gas safety valves

Air-cooled door to prevent overheating

Connected load nominal power: 240/120V - 15 Amps

Voltage rating: 240/120V 60Hz

ACCESSORIES INCLUDED:

1 wok ring

1 deep oven tray

1 total-extraction telescopic guide

2 chrome shelves

1 Island trim

OPTIONS:

BGTR9 Grill plate

GT1T-2 1-level telescopic shelf total extraction

PPR9 Pizza stone

TPKTR9 Teppanyaki grill plate

TRU36GGWH9

FREE-STANDING ALL-GAS "VICTORIA" RANGE, 36" X 25", WHITE



Traditional Style

Soft Close oven door

Full-width continuous grates

Stainless steel storage drawer beneath the oven

GAS OVEN:

4 cooking modes



Programmable Timer with Touch display

Adjustable thermostat 120° - 500° F

Air-cooled triple-glazed removable door

Triple Convection

Oven capacity: 4.5 cu ft

EverClean enameled interior cavity

5 shelf positions

2 x halogen oven lights

GAS RANGETOP:

5 gas burners

Right-rear: 8,000 BTUs

Left-rear: 8,000 BTUs

Central double-inset super burner: 20,000 BTUs

Right-front: 4,500 BTUs

Left-front: 12,000 BTUs

Heavy-duty cast-iron grates

Automatic electric ignition

LP gas conversion kit included

SAFETY:

Gas safety valves

Air-cooled door to prevent overheating

Connected load nominal power: 200 W - 2 Amps

Voltage rating: 120V 60Hz

ACCESSORIES INCLUDED:

1 wok ring

1 deep oven tray

1 total-extraction telescopic guide

2 chrome shelves

1 Island trim

OPTIONS:

BGTR9 Cast-iron grill plate

GT1T-2 1-level telescopic shelf total extraction

PPR9 Pizza stone

TPKTR9 Teppanyaki grill plate

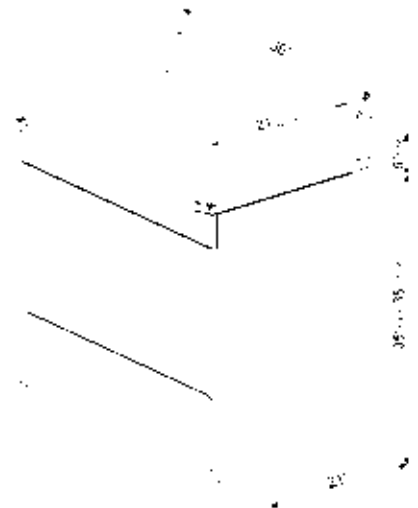

TRU36

For technical drawing in metric, see page 174



TRU36GGWH with KTU36WH hood

TRU90P

FREE-STANDING DUAL-FUEL CAVITY "VICTORIA" RANGE, 36" X 25", CREAM



TRU90X
Stainless Steel



TRU90BL
Glossy Black

Traditional Style

Electronic clock with programmable features
Full-width continuous grates
Stainless steel storage drawer beneath the oven
5 1/3" stainless steel backsplash

MULTIFUNCTION ELECTRIC OVEN:

8 cooking modes



Programmable timer
Adjustable thermostat 120° - 500° F
Air-cooled triple-glazed removable door
True European Double Convection
Oven capacity: 4.4 cu ft
EverClean enameled interior cavity
4 shelf positions
2 halogen oven lights
Bake element 3.0 kW
Broil element 2.9 kW
Convection element 1.55 kW

GAS RANGETOP:

5 gas burners
Right-rear: 6,500 BTUs
Left-rear: 6,500 BTUs
Central double-inset super burner: 18,000 BTUs
Right-front: 3,400 BTUs
Left-front: 10,000 BTUs
Heavy-duty cast-iron grates
Automatic electric ignition
LP gas conversion kit included

SAFETY:

Gas safety valves
Air-cooled door to prevent overheating

Connected load nominal power: 240/120V
Voltage rating: 240/120V 60Hz
Amp supply required: 240/120V - 15/13.5 Amps
Gas inlet location: back top-right

ACCESSORIES INCLUDED:

1 wok ring
1 moka ring
1 rotisserie kit
2 baking trays
2 chrome shelves

OPTIONS:

KIT1TR90-1 Black island trim
KIT1TR9N Black backsplash
KIT1TR9X Stainless steel backsplash
KIT1TR90X-1 Stainless steel island trim
TPKTR9 Teppanyaki grill plate

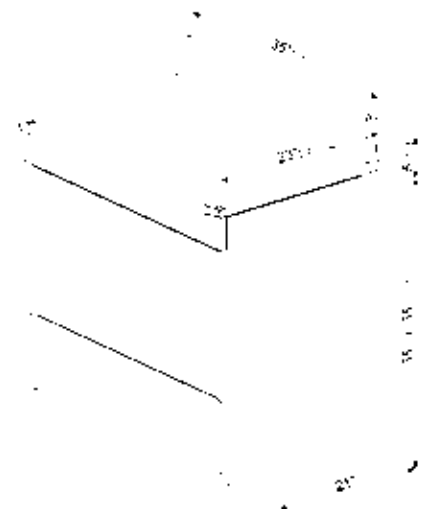

For technical drawing in metric, see page 174



KTU36X with backslash and TRU90X range

TRU36GGBL

FREE-STANDING ALL-GAS "VICTORIA" RANGE,
36", GLOSSY BLACK



TRU36GGX
Stainless Steel



TRU36GGP
Cream

Traditional Style

Electronic clock with programmable features
Full-width continuous grates
Stainless steel storage drawer beneath the oven

GAS OVEN:

5 cooking modes



Programmable timer
Adjustable thermostat 122° -500° F
Air-cooled triple-glazed removable door
True European convection
Oven capacity: 4.4 cu ft
EverClean enameled interior cavity
4 shelf positions
2 halogen oven lights
Bake element 1.7 kW
Broil element 2.9 kW
Convection element 1.55 kW

GAS RANGETOP:

5 gas burners
Right-front: 6,500 BTUs
Right-rear: 6,500 BTUs
Central double-inset super burner: 18,000 BTUs
Left-front: 3,400 BTUs
Left-rear: 10,000 BTUs
Heavy-duty cast-iron grates
Automatic electric ignition
LP gas conversion kit included

SAFETY:

Gas safety valves
Air-cooled door to prevent overheating
Connected load nominal power: 240/120V
Voltage rating: 240/120V 60Hz
Amp supply required: 240/120V - 15/13.5 Amps
Gas inlet location: back top-right

ACCESSORIES INCLUDED:

1 wok ring
1 moka ring
1 rotisserie kit
2 baking trays
2 chrome shelves
5 -1/2" backsplash
1 1/4" Island trim

OPTIONS:

KIT1TR9N Black backsplash
KIT1TR9X Stainless steel backsplash
TPKTR9 Teppanyaki grill plate

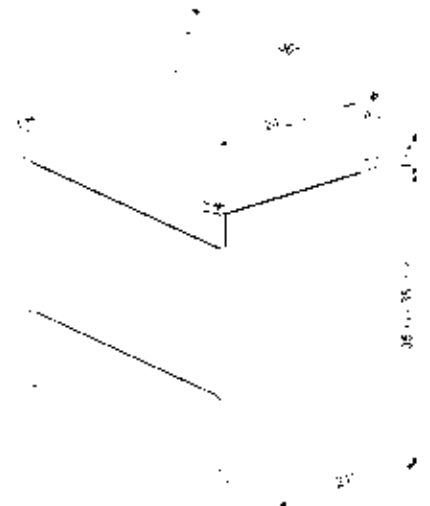

For technical drawing in metric, see page 174



KTU36P hood with TRU36GGP range

C36GGXU

FREE-STANDING GAS RANGE,
36", STAINLESS STEEL



C36GGRU
Red



C36GGBU
White



C36GGNU
Black

Professional Style

ANSI 304 stainless steel
Sturdy American-style control knobs
4" polished stainless steel backsplash

GAS OVEN:

3 cooking modes



Gas double convection mode
Broil mode
Defrost mode
Fan option for static gas
EverClean enameled oven interior
4 shelf positions
Air-cooled triple-glazed removable door
2 halogen oven lights
Oven capacity: 4.4 cu ft

GAS RANGETOP:

Heavy-duty cast-iron grates
Full-width grates
Sealed burners
Automatic electronic ignition
Safety valves
LP gas conversion kit included

6 GAS BURNERS:

Front-right:	6,200 BTUs
Back-right:	10,000 BTUs
Front-center:	3,400 BTUs
Back-right double-inset super burner:	15,000 BTUs
Front-left:	6,200 BTUs
Back-left:	3,400 BTUs

SAFETY:

Gas safety valves
Ventilated door with cooling system to prevent overheating
Anti-tilting norms satisfied
Suitable for built-in applications

Connected load nominal power: 120V
Amp supply required: 120V - 1.2 Amps
Voltage rating: 120V 60Hz
Gas inlet location: back top-right

ACCESSORIES INCLUDED:

1 baking tray
1 chrome shelf
1 wire rack
1 wok ring
1 moka ring

OPTIONAL ACCESSORIES:

KITI36XU Island trim
8MCCU "Classic" control knob kit

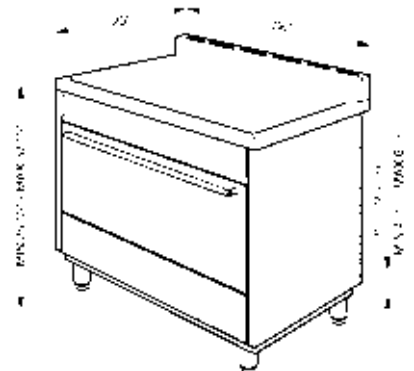

For technical drawing in metric, see page 174



C30GGXU1

FREE-STANDING GAS RANGE,
30", STAINLESS STEEL



C30GGRU
Red



C30GGBU
White



C30GGNU
Black

Professional Style

ANSI 304 stainless steel
Sturdy American-style control knobs
4" polished stainless steel backsplash

GAS OVEN:

3 cooking modes



Gas convection mode
Broil mode
Defrost mode
Timer with alarm
Air-cooled triple-glazed removable door
EverClean enameled oven interior
4 shelf positions
2 halogen oven lights
Oven capacity: 3.6 cu ft

GAS RANGETOP:

Heavy-duty cast-iron grates
Full-width grates
Sealed burners
Automatic electronic ignition incorporated in the control knobs
LP gas conversion kit included
Deep rangetop base to contain spillage

5 GAS BURNERS:

Front-right: 10,100 BTUs
Back-right: 10,100 BTUs
Center: 17,000 BTUs
Front-left: 10,100 BTUs
Back-left: 10,100 BTUs
4 burners with True Simmer function

SAFETY:

Gas safety valves
Ventilated door with cooling system to prevent overheating
Anti-tilting norms satisfied
Suitable for built-in applications

Connected load nominal power: 120V
Amp supply required: 120V 1.2Amps
Voltage rating: 120V 60Hz
Gas inlet location: back top-right

ACCESSORIES INCLUDED:

1 baking tray
1 chrome shelf
1 wok ring
1 moka ring

OPTIONAL ACCESSORIES:

KIT130XU Island trim
8MCCU "Classic" control knob kit

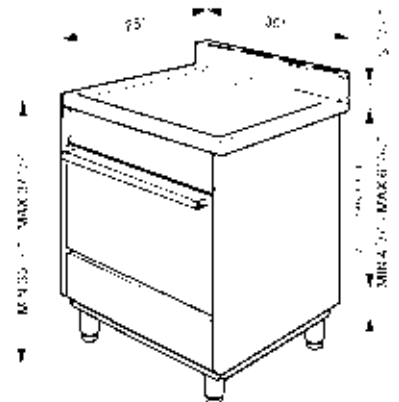

For technical drawing in metric, see page 174

C24GGXU

FREE-STANDING GAS RANGE,
24", STAINLESS STEEL



Professional Style

AlSI 304 stainless steel
Sturdy American-style control knobs
4" polished stainless steel backsplash

GAS OVEN:

3 cooking modes



Gas convection mode
Broil mode
Defrost mode
Air-cooled triple-glazed removable door
EverClean enameled oven interior
5 shelf positions
2 halogen oven lights
Oven capacity: 2.8 cu ft

GAS RANGETOP:

Heavy-duty cast-iron grates
Full-width grates
Sealed burners
Automatic electronic ignition
Safety valves
LP gas conversion kit included

4 GAS BURNERS:

Front-right: 6,200 BTUs
Back-right double-inset super burner: 15,000 BTUs
Back-left: 3,400 BTUs
Front-left: 6,200 BTUs

Connected load nominal power: 120V
Amp supply required 120V 1.2 Amps
Voltage rating: 120V 60Hz
Gas inlet location: back top-right

SAFETY:

Gas safety valves
Ventilated door with cooling system to prevent overheating
Anti-tilting norms satisfied
Suitable for built-in applications

ACCESSORIES INCLUDED:

1 baking tray
2 chrome shelves
1 wok ring
1 moka ring

OPTIONAL ACCESSORIES:

KIT124XU Island trim
GT1T-1 Telescopic guides - full-extension
GT1P-1 Telescopic guides - half-extension
8MCCU "Classic" control knob kit

HIGH PERFORMANCE FOR SMALL SPACES



5 cooking positions to cook various dishes at the same time, or to easily accommodate large items

- Largest cavity oven in its class (2.8 cu ft)

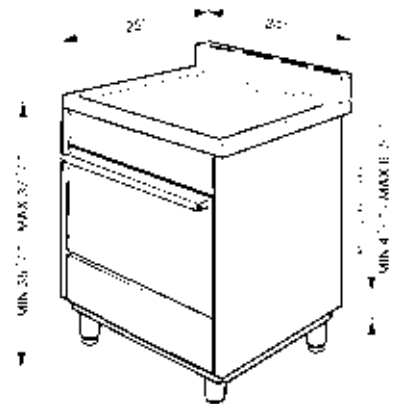

For technical drawing in metric, see page 174

S9GMXU9

FREE-STANDING DUAL-FUEL RANGE,
APPROX. 36", STAINLESS STEEL



Professional Style

Stainless steel
Sturdy American-style control knobs
Island trim backsplash

MULTIFUNCTION ELECTRIC OVEN:

8 cooking modes

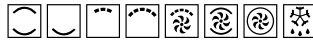

Programmable timer with touch display
Air-cooled double-glazed removable door
True European Double convection
EverClean enameled oven interior
5 shelf positions
2 oven lights
Oven capacity: 4.5 cu ft
Bake element 1.2 kW
Broil element 1.8 kW
Convection element 2.9 kW

GAS RANGETOP:

Heavy-duty castiron grates
Full-width grates
Sealed burners
Automatic electronic ignition
Safety valves
LP gas conversion kit included

5 GAS BURNERS:

Front-right: 3,400 BTUs
Back-right: 6,200 BTUs
Central double-inset super burner: 14,000 BTUs
Front-left: 9,000 BTUs
Back-left: 6,200 BTUs

SAFETY:

Gas safety valves
Ventilated door with cooling system to prevent overheating
Anti-tilting norms satisfied
Suitable for built-in applications

Connected load nominal power: 240/120V – 3.7kW

Amp supply required 240/120V 15 Amps

Voltage rating: 240/120V 60Hz

Gas inlet location: back top-right

ACCESSORIES INCLUDED:

1 baking tray
2 chrome shelves
1 moka ring

OPTIONAL ACCESSORIES:

KITI9XU Island trim
KITPS9U Stainless steel toe kick

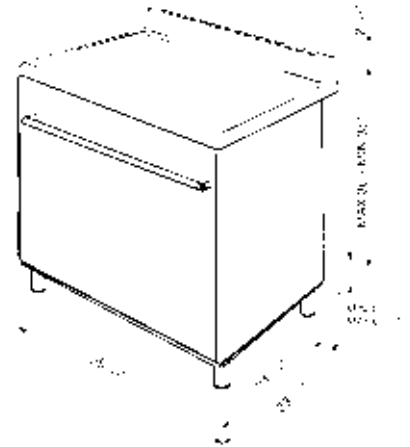

For technical drawing in metric, see page 174

COOKING ACCESSORIES

SMEG offers a variety of accessories for ovens, cooktops, and ranges, which enhance the appliances, and provide added flexibility.

GT1T-2

1-LEVEL TELESCOPIC SHELF - TOTAL-EXTRACTION



Pair of fully-extractable telescopic guides.
ALSO AVAILABLE: **GT1P-1** Telescopic shelf set with 1 partially-extractable level.

DICAR

SIMMER PLATE



5pc simmer plate pack suitable for use on all SMEG ranges and gas cooktops.

PRTX

PIZZA STONE WITH HANDLES



Refractory pizza stone with handle, suitable for use with SF399XU. With the oven set at 250°, the pizza stone allows you to cook a very Italian pizza in only 4 minutes.

GO120

CAST-IRON OPEN GRIDDLE FOR BARBECUE



The GO120 is intended to replace the plate on A3XU7 ranges with the electric griddle, to convert it to a barbecue.

TPKTR9

TEPPANYAKI GRILL PLATE



Stainless steel grill plate designed for cooking teppanyaki dishes. Suitable for Portofino 36" and Victoria series.

WOKGHU

CAST-IRON WOK SUPPORT



The WOKGHU offers additional stability when using a wok. Suitable for most ranges and cast-iron gas cooktops, except for all "Classic" front control 24" gas cooktops.

MODEL/DESCRIPTION/COMPATIBLE WITH:

TPKCPF30	Teppanyaki grill plate suitable for Portofino 30"	CPF30
BGTR9	Cast-iron grill plate suitable for Victoria and Portofino 36"	CPF36
BGTR4110	Cast-iron Grill Plate for Portofino 48"	CPF48
BGCPF30	Cast-iron grill plate suitable for Portofino 30"	CPF30
TPKX	Teppanyaki grill plate	A3XU7
KIT3A31-6	Extension kit to rise the appliance by 1"	A3XU7
KIT1A3-6	Backsplash	A3XU7
KITIA1	Island trim	
KIT2A1-2	Toe kick in brushed stainless steel	
KIT3-6	2" height extension	
KITI36XU	Island trim	C36GGXU
KITI30XU	Island trim	C30GGXU-1
KITI24XU	Island trim	C24GGXU
KITI9XU	Island trim	S9GMXU
KITDS9U	Depth extension kit	S9GMXU9
KITPS9U	Stainless steel plinth	S9GMXU9
KITTR90X-1	Island trim, stainless steel	TRU90P, TRU90X, TRU90BL
KIT1TR9N	Black backspalsh	TRU90BL
KITTR90-1	Island trim, black	TRU90BL, TRU90P, TRU90X
KIT1TR9X	Stainless steel backsplash	TRU90P, TRU90X, TRU90BL
PALPZ	Pizza shovel with fold away handle	
PPR9	Refractory pizza stone, square shape	
GTA-6	3-level telescopic shelf set	A1PXU, A3XU7
8MCCU	"Classic" control knobs kit	C24GGXU, C30GGXU1, C36GGXU

HOODS

Hoods play an important role in the kitchen, both aesthetic and functional. Designed to offer the best combination of styling and functionality, SMEG hoods reflect the elegance and style of their matching appliances.



KPF48UOG

48" PORTOFINO VENTILATION HOOD, OLIVE GREEN



KPF48URD
Red



KPF48UYW
Yellow



KPF48UWH
White



KPF48UOR
Orange



KPF48UBL
Black



KPF48UOG
Olive Green



KPF48UX
Stainless Steel



KPF48UAN
Matte Black

Portofino Design

Wall-mounted ventilation hood
Control adjustment knobs
3 speeds and additional intensive speed
4 LED lights
Motor power: 455 W
4 stainless steel grease filters
600 CFM max setting
Electrical connection rating: 535 W - 5 Amps
Voltage: 120V 60Hz

OPTIONS:

FLTK-1 Charcoal filter
KITREDCFM CFM reducer

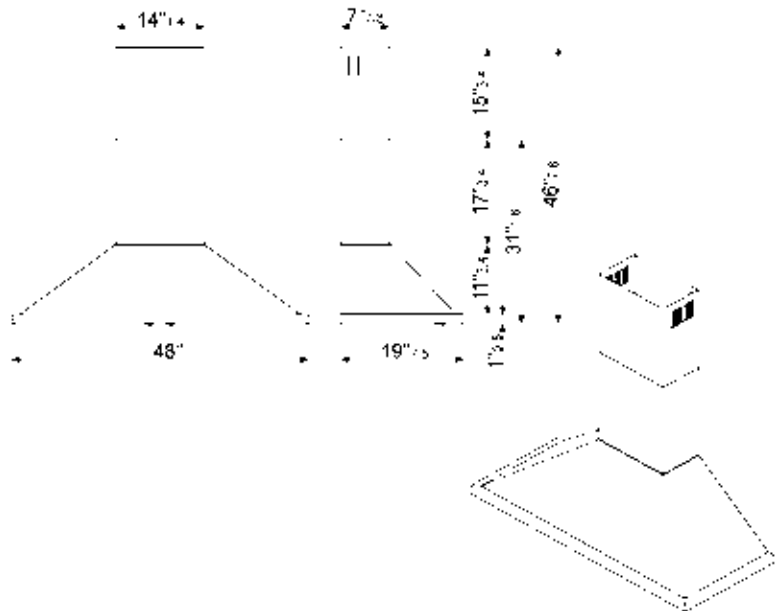

For technical drawing in metric, see page 175



KPF48UYW hood with backsplash and CPF48UGMYW range

KPF36UOR

36" PORTOFINO VENTILATION HOOD, ORANGE



KPF36URD
Red



KPF36UYW
Yellow



KPF36UWH
White



KPF36UOR
Orange



KPF36UBL
Black



KPF36UOG
Olive Green



KPF36UX
Stainless Steel



KPF36UAN
Matte Black

Portofino Design

Wall-mounted ventilation hood
Control adjustment knobs
3 speeds and additional intensive speed
2 LED lights
Motor power: 455 W
3 stainless steel grease filters
600 CFM max setting
Electrical connection rating: 495 W - 5 Amps
Voltage: 120V 60Hz

OPTIONS:

FLTK-1 Charcoal filter
KITREDCFM CFM reducer

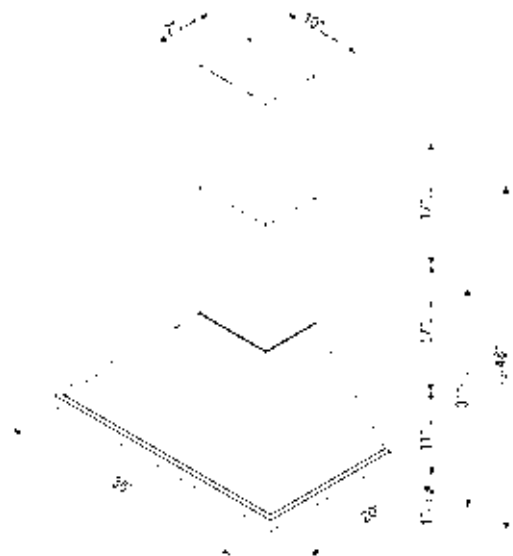

For technical drawing in metric, see page 175

KPF30UX

30" PORTOFINO VENTILATION HOOD, STAINLESS STEEL

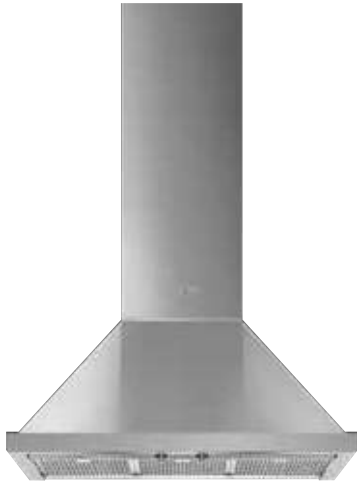

KPF30URD
Red



KPF30UYW
Yellow



KPF30UWH
White



KPF30UOR
Orange



KPF30UBL
Black



KPF30UOG
Olive Green



KPF30UX
Stainless Steel



KPF30UAN
Matte Black

Portofino Design

Wall-mounted ventilation hood
Control adjustment knobs
3 speeds and additional intensive speed
2 LED lights
Motor power: 455 W
3 aluminium grease filters
600 CFM max setting
Electrical connection rating: 485 W - 5 Amps
Voltage: 120V 60Hz

OPTIONS:

FLTK-1 Charcoal filter
KITREDCFM CFM reducer

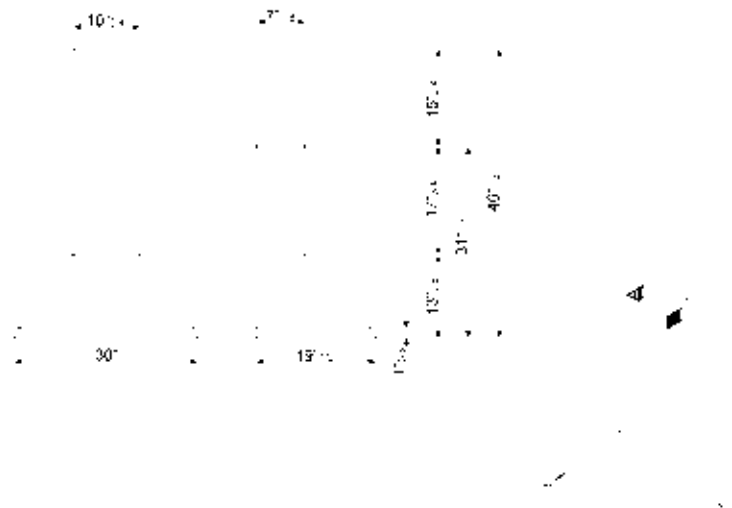

For technical drawing in metric, see page 175

KTU36P

36" VICTORIA VENTILATION HOOD, CREAM



KTU36X
Stainless steel



KTU36BL
Glossy Black



KTU36WH
White

Traditional Victoria Design

Wall-mounted ventilation
Stylish ergonomic control knobs
Front-mounted controls for lights and vent speeds

- 1 fan motor
- 4 speeds
- 2 halogen lights (2x20W)
- 3 dishwasher-safe aluminium grease filters

Vented or recirculating

600 CFM max setting
Vent duct size: 6"

Voltage rating: 120V/60Hz/4.5 Amps
Nominal power: 445 W

OPTIONS:

- FLTK-1 Charcoal filter
- KITCMNKPU Cream chimney extension
- KITCMNKXU Stainless steel chimney extension
- KITCMNKBU Black chimney extension

VENT OUT RECIRCULATION

SMEG hoods can operate in either a ducted or recirculation mode. Best performance is achieved in the ducted mode, the preferred choice wherever possible.

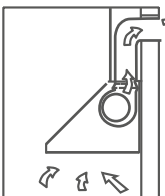

Extractor hood: extracts the cooking fumes and expels them outside, using a vent kit. The diameter of the ducting hose should match the vent outlet of the hood.

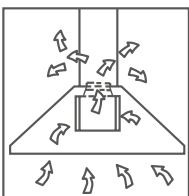

Filter hood: extracts the cooking fumes and passes them through active charcoal filters, recirculating the cleaned air into the room.

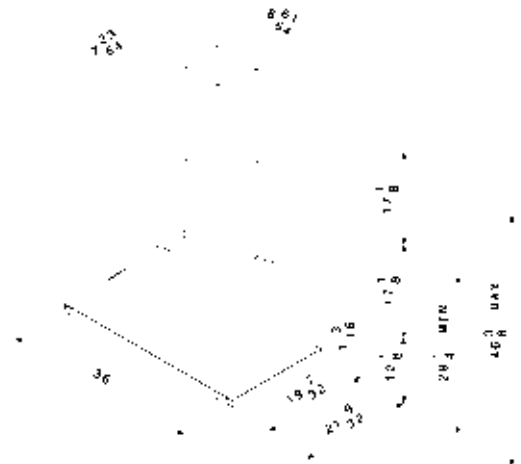

For technical drawing in metric, see page 175



KTU36P hood with TRU36GGP range

KD120XU

120 CM (APPROX. 48") VENTILATION HOOD,
STAINLESS STEEL



"Classic" Design

Wall-mounted ventilation
Stylish ergonomic control knobs
Premium-quality stainless steel
Front-mounted controls for lights and vent speeds

1 twin fan motor 240 W
4 speeds
2 halogen bulbs (2x20W)
4 dishwasher-safe stainless steel grease filters

Vented or recirculating

770 CFM max setting
Vent duct size: 6"

Voltage rating: 120V/60Hz/4.5 Amps
Nominal power: 485 W

OPTIONS:

FLTK1 Charcoal filter
KITCMNKD Chimney extension
KITREDCFM CFM reducer

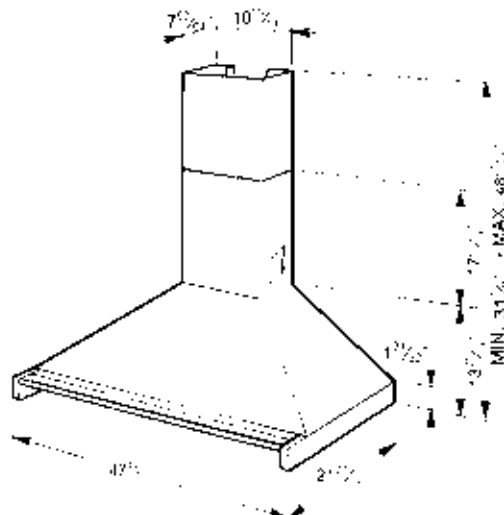

For technical drawing in metric, see page 175

KD90XU

90 CM (APPROX. 36") VENTILATION HOOD,
STAINLESS STEEL



"Classic" Design

Wall-mounted ventilation
Stylish ergonomic control knobs
Premium-quality stainless steel
Front-mounted controls for lights and vent speeds

1 fan motor
4 speeds
2 halogen bulbs (2x20W)
3 dishwasher-safe stainless steel grease filters

Vented or recirculating

600 CFM max setting
Vent duct size: 6"

Voltage rating: 120V/60Hz/4.5 Amps
Nominal power: 485 W

OPTIONS:

FLTK1 Charcoal filter
KITCMNKD Chimney extension
KITREDCFM CFM reducer

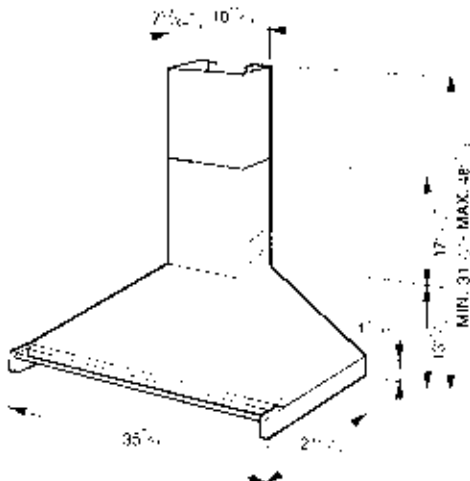

For technical drawing in metric, see page 175

KDU30X

30" VENTILATION HOOD,
STAINLESS STEEL



"Classic" Design

Wall-mounted ventilation
Stylish ergonomic control knobs
Premium-quality stainless steel
Front-mounted controls for lights and vent speeds

1 fan motor
4 speeds
2 halogen bulbs (2x20W)
3 dishwasher-safe stainless steel grease filters

Vented or recirculating

600 CFM max setting
Vent duct size: 6"

Voltage rating: 120V/60Hz/4.5 Amps
Nominal power: 485 W

OPTIONS:

FLTK1 Charcoal filter
KITCMNKD Chimney extension
KITREDCFM CFM reducer

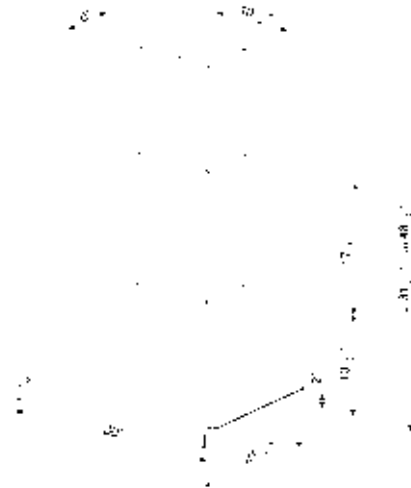

For technical drawing in metric, see page 175

KSM36XU

90 CM (APPROX. 36"), VENTILATION HOOD,
STAINLESS STEEL



Flat Design

Wall-mounted ventilation hood
High-quality stainless steel
Front-mounted controls for lights and vent speeds

1 motor
Vented or recirculating
4 speeds
3 halogen lights (3x20W)
3 dishwasher-safe grease filters

600 CFM max. setting
Vent duct size: 6"
Voltage rating: 120V/60Hz/4.5 Amps

OPTIONS:

KITFC161 Charcoal filter
KITSMNKSM Chimney extension

FEATURES AT A GLANCE

To assist in the selection of the right hood, a number of symbols appear beneath each model, and help to check and compare the products on offer. Some examples are shown here, but details of the full range of symbols can be found at the back of the catalogue.



Electronic display to give a visual reminder of the options selected



Touch control panel, all options selected at the touch of a fingertip



Intensive/turb setting, when extra-fast extraction is required



Warning light(s), to advise when filters need changing

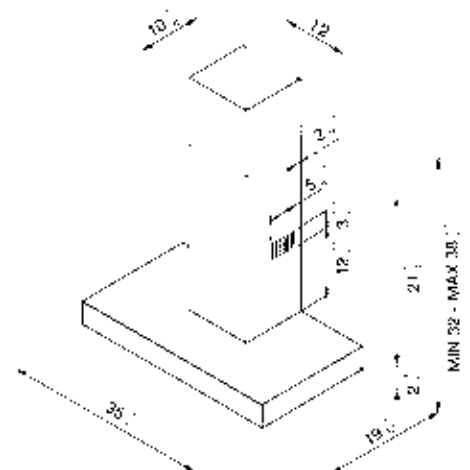

For technical drawing in metric, see page 175

KSM30XU

30" VENTILATION HOOD,
STAINLESS STEEL



Flat Design

Wall-mounted ventilation hood
High-quality stainless steel
Front-mounted controls for lights and vent speeds

1 motor
Vented or recirculating
3 speeds
2 halogen lights (2x20W)
2 dishwasher-safe grease filters

600 CFM max. setting
Vent duct size: 6"
Voltage rating: 120V/60Hz/4.5 Amps

OPTIONS:

KITFC161 Charcoal filter
KITSMNKSM Chimney extension
KITREDCFM CFM reducer

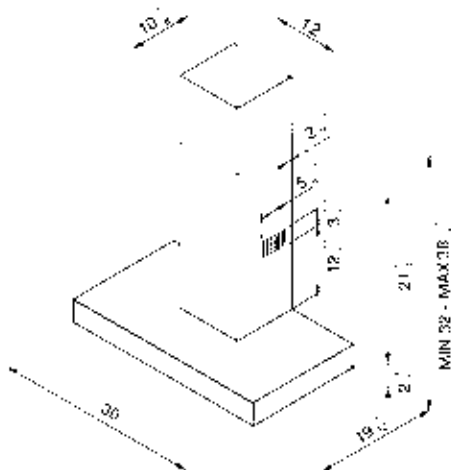

For technical drawing in metric, see page 175

KSM24XU

60 CM (APPROX. 24"), VENTILATION HOOD,
STAINLESS STEEL



Flat Design

Wall-mounted ventilation hood
High-quality stainless steel
Front-mounted controls for lights and vent speeds

1 motor
Vented or recirculating
4 speeds
2 halogen lights (2x20W)
3 dishwasher-safe grease filters

600 CFM max. setting
Vent duct size: 6"
Voltage rating: 120V/60Hz/4.5 Amps

OPTIONS:

KITFC161 Charcoal filter
KITSMNKSM Chimney extension
KITREDCFM CFM reducer

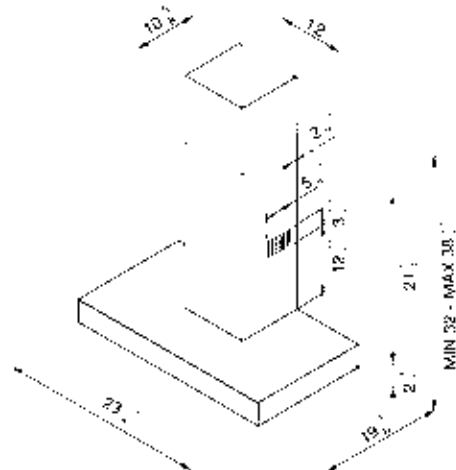

For technical drawing in metric, see page 176

KUC48X

48" PRO-STYLE, UNDER-CABINET HOOD, STAINLESS STEEL



Pro-Style

Under-cabinet hood
High-quality stainless steel
Pro-Style and Portofino knobs

1 motor
Vented or recirculating
4 speeds
2 halogen lights (2x20W)
3 dishwasher-safe grease filters

600 CFM max. setting
Vent duct size: 6"
Voltage rating: 120V/60Hz/4.5 Amps
Nominal power: 455 W

OPTIONS:

FLTK-1 Charcoal filter

KUC36X

36" PRO-STYLE, UNDER-CABINET HOOD, STAINLESS STEEL



Pro-Style

Under-cabinet hood
High-quality stainless steel
Pro-Style and Portofino knobs

1 motor
Vented or recirculating
4 speeds
2 halogen lights (2x20W)
3 dishwasher-safe grease filters

600 CFM max. setting
Vent duct size: 6"
Voltage rating: 120V/60Hz/4.5 Amps
Nominal power: 455 W

OPTIONS:

FLTK-1 Charcoal filter

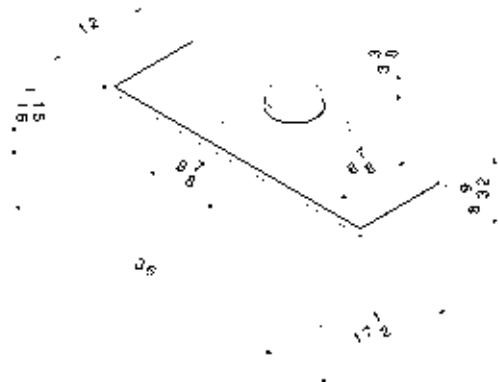

KUC30X

30" PRO-STYLE, UNDER-CABINET HOOD, STAINLESS STEEL



Pro-Style

Under-cabinet hood
High-quality stainless steel
Pro-Style and Portofino knobs

1 motor
Vented or recirculating
4 speeds
2 halogen lights (2x20W)
2 dishwasher-safe grease filters

600 CFM max. setting
Vent duct size: 6"
Voltage rating: 120V/60Hz/4.5 Amps
Nominal power: 455 W

OPTIONS:

FLTK-1 Charcoal filter

KUC24X

24" PRO-STYLE, UNDER-CABINET HOOD, STAINLESS STEEL



Pro-Style

Under-cabinet hood
High-quality stainless steel
Pro-Style and Portofino knobs

1 motor
Vented or recirculating
4 speeds
2 halogen lights (2x20W)
2 dishwasher-safe grease filters

600 CFM max. setting
Vent duct size: 6"
Voltage rating: 120V/60Hz/4.5 Amps
Nominal power: 455 W

OPTIONS:

FLTK-1 Charcoal filter

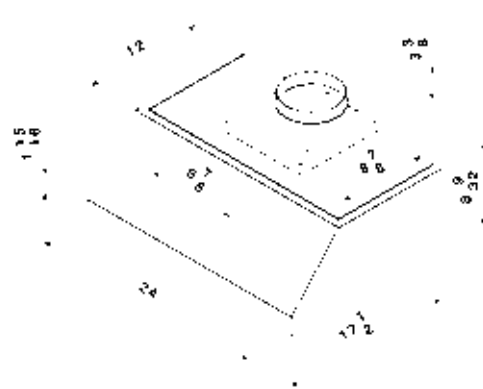

OVENS

Exceptional materials, state-of-the-art technology, and an uncompromising approach to aesthetics are the guiding principles behind SMEG's acclaimed built-in ovens.



CLEANING MADE SIMPLE

maximum attention to hygiene



VAPOR-CLEAN

The eco-friendly Vapor-Clean function facilitates cleaning through the use of steam. This steam is generated by inserting a small amount of water into the groove in the cavity, with no need for chemical additives. This process also uses less energy.

TILTING GRILL

The grill can be easily unhooked to move the heating element away, and clean the roof of the appliance in one simple step.

EVERCLEAN ENAMEL

The enamel finish of the oven cavities have a special lining that helps to reduce the amount of dirt and grime that adheres to the surface.



SELF-CLEANING

This automatic cleaning function works by heating the inside of the oven to 930°F to burn off any grease and dirt. For a safer environment, all self-clean ovens feature quadruple-glazed door, and Fresh Touch door.



FRESH TOUCH DOOR

All pyrolytic ovens feature a Fresh Touch door, which means that during the pyrolytic cleaning cycle, the outer glass will become no hotter than 130°F. A special device also locks the door for the duration of the process, which along with quadruple-glazed doors, provides total safety.

REMOVABLE INNER DOOR

The single flat surface of the inner glass door is totally removable, to make cleaning an easy task.



EUROPEAN CONVECTION

Many SMEG ovens feature true European convection, where an additional heating element heats the air as it comes through the convection fans, allowing for more-even and more-efficient heating.

SPECIAL FUNCTIONS

a truly Italian pizza in 4 minutes



REFRACTORY STONE

A pizza stone accessory placed at the base of the oven cavity above the lower heating element allows for a perfect pizza to be cooked in just 3 to 5 minutes.

Some SMEG wall ovens are equipped with a special system which places the heating element in direct contact with a pizza stone accessory, allowing you to create perfect, delicious, evenly-cooked pizzas in just 3 to 4 minutes, or 5 minutes with toppings. They can also provide excellent results when cooking breads, pies, and more, even vegetables, and fish in foil without having to dry them out.

SFU6104TVS

60 CM (APPROX. 24") LINEA DESIGN
MULTIFUNCTION OVEN, MYSTIC GRAY GLASS



Linea Design

Multifunction oven with 10 cooking modes



Touch screen controls

Mystic Gray glass finish

Color TFT touch screen display

SmartCook System

50 automatic cooking program

10 customizable recipes

Electronic temperature control

True European convection

Adjustable temperature: 87 - 536° F

Rapid preheat

Vapor-Clean system

EverClean enamel cavity for quick and easy cleaning

Automated oven switch-off when door is open

5 rack positions

Soft Close door

Double-insulated cavity

Air-cooled door

Ceramic catalyst fume control

Child-safe control lock

Safe-touch cooling

Quadruple-glazed removable door

Quickly removable, easy-to-clean inner door glass

2 Halogen lights (2 x 40 W)

Oven capacity: 2.8 cu ft

Bake element: 1,700W @ 240V

Broil element: 2,700W @ 240V

Convection element: 2,000W @ 240V

Voltage rating: 120/240V 60Hz

Connected load (nominal power): 3 kW

Amps: 14 Amps

ACCESSORIES INCLUDED:

1 telescopic guide rail (total extraction)

1 wire rack with tray insert

1 wire rack

1 deep enamel tray

2 enamel trays

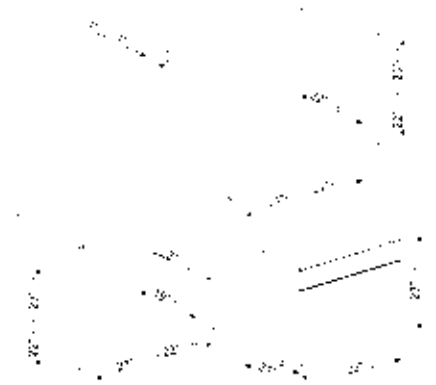

For technical drawing in metric, see page 177



LINEA

OVENS

SOU130S1

SELF-CLEANING

76 CM (APPROX. 30") LINEA DESIGN
MULTIFUNCTION OVEN, MYSTIC GRAY GLASS



Linea Design

Multifunction oven with 6 cooking modes

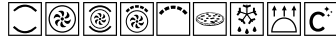

Touch screen controls

Mystic Gray glass finish

Color TFT touch screen display

70 automatic cooking program

Defrost by time, defrost by weight, rising, dehydrate, and self-cleaning cycle

True European double convection

Fast preheat cycle (8 - to - 12 minutes)

Adjustable temperature: 80° - 590°F

Automated oven switch-off when door is open

Self-cleaning

Sabbath mode

Child safety locks

6 rack positions

Air-cooled door

Triple-glazed removable door

Oven capacity: 4.34 cu ft

Interior dimensions: W 24" x H 16 - 1/8" x D 16 - 5/16"

Concealed bake element

Broil element 3.5 kW

Voltage rating: 240/208V 60Hz

Connected load (nominal power): 240/208V:

16.9/17.5 Amps

Power supply location: center-top

ACCESSORIES INCLUDED:

1 grid insert for tray

2 grid tops

1 telescopic guide

1 enameled tray

1 meat probe

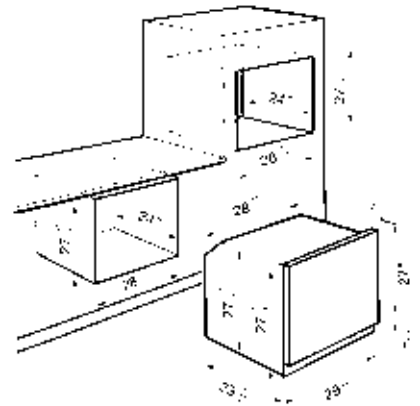

For technical drawing in metric, see page 177



LINEA

OVENS

SC712U

70 CM (APPROX. 27") LINEA DESIGN
MULTIFUNCTION OVEN, STAINLESS STEEL AND SUPERSILVER
GLASS



Linea Design

Multifunction oven with 12 cooking modes



Stainless steel Supersilver glass finish
Ergonomic backlit transparent controls
Digital electronic program feature with multi-display
Automated oven switch-off when door is open
Electronic temperature control
Stay-clean liners
Air-cooled door
Triple-glazed removable door
Quickly removable, easy-to-clean inner
door glass

Oven capacity: 3.2 cu ft
Interior dimensions: W 22 ⁵/₁₆" x H 12 ³/₁₆" x D 16"
Adjustable temperature: 86° - 536° F
Voltage rating: 240/208V 60 Hz
Connected load (nominal power): 240/208V
3.7/2.76kW
Amps @ 240/208V: 15.4/13.2 Amps
Power supply location: Back-right bottom

ACCESSORIES INCLUDED:

- 1 baking tray
- 1 broil pan with broiler rack
- 2 wire racks
- 1 rotisserie kit



OPTIONS:

GT90X - 3-level telescopic rack set

SF112U

60 CM (APPROX. 24") LINEA DESIGN
MULTIFUNCTION OVEN, STAINLESS STEEL AND
SUPERSILVER GLASS



Linea Design

Multifunction oven with 12 cooking modes



Stainless steel Supersilver glass finish
Ergonomic backlit transparent controls
Silver glass & stainless finish
Digital electronic program feature with multi-display
Dual digital displays for cooking readouts
Electronic temperature control
Adjustable temperature 105 - 480° F
Rapid preheat
Double-insulated cavity
Ceramic catalyst fume control
Multi-glazed removable door
Safe-touch cooling

Oven capacity: 2.8 cu ft
Bake element: 2,200W @ 240V
Broil element: 2,700W @ 240V
Convection element: 2,000W @ 240V
Voltage rating: 240/120V 60 Hz
Connected load (nominal power): 3.5 kW
Amps: 14 Amps

ACCESSORIES INCLUDED:

- 1 wire rack with tray insert
- 1 wire rack
- 1 deep enamel tray

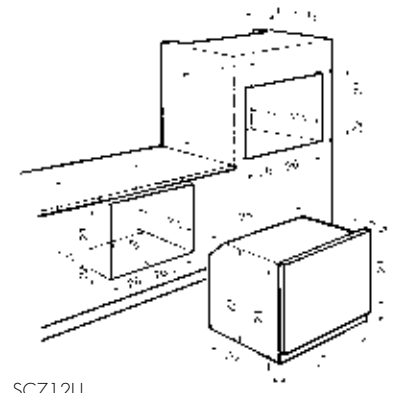

SC712U



SF112U

For technical drawing in metric, see page 177

SOU130S

SELF-CLEANING

76 CM (APPROX. 30") LINEA DESIGN
ELECTRIC MULTIFUNCTION OVEN, STAINLESS STEEL AND SUPER SILVER GLASS



Linea Design

Multifunction oven with 6 cooking modes

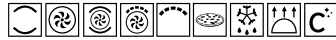

- Stainless steel Supersilver glass finish
- Defrost by time, defrost by weight, rising, dehydrate, and self-cleaning cycle
- Digital display
- True European double convection
- Fast preheat cycle (8 to 12 minutes)
- Adjustable temperature: 86° - 554° F
- Automated oven switch-off when door is open
- Self-cleaning
- Sabbath mode
- Child safety locks
- 6 rack positions
- Air-cooled door
- Triple-glazed removable door

- Oven capacity: 4.34 cu ft
- Interior dimensions: W 24" x H 16 - 1/8" x D 16 - 5/16"
- Concealed bake element
- Broil element 3.5 kW
- Voltage rating: 240/208V 60 Hz
- Connected load (nominal power): 240/208V: 16.9/17.5 Amps
- Power supply location: center-top

ACCESSORIES INCLUDED:

- 1 grid insert for tray
- 2 grid tops
- 1 telescopic guide
- 1 enameled tray
- 1 meat probe

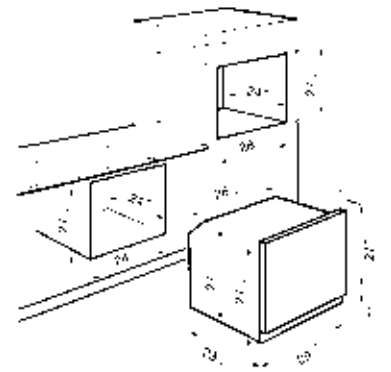

For technical drawing in metric, see page 177

SFU7302TVX

70 CM (APPROX. 27") "CLASSIC" DESIGN
MULTIFUNCTION OVEN, STAINLESS STEEL AND SMART-BLACK GLASS



"Classic" Design

Multifunction oven with 9 cooking modes



Stainless steel and Smart-black glass finish
Fingerprint-proof stainless steel
Ergonomic control knobs

Large LCD display

20 automatic cooking program

Automated oven switch-off when door is open
Electronic temperature control

True European convection

Adjustable temperature 87 - 536° F
Rapid preheat

Vapor-Clean system

EverClean enamel cavity for quick and easy cleaning

4 rack positions

Double-insulated cavity

Air-cooled door

Ceramic catalyst fume control

Child-safe control lock

Safe-touch cooling

Triple-glazed removable door

Quickly-removable, easy-to-clean inner door glass

2 Halogen lights (2 x 40 W)

Oven capacity: 3.2 cu ft

Interior dimensions: W 24" x H 16 1/8" x 16 5/16"

Voltage rating: 240/208V 60 Hz

Connected load (nominal power): 240/208V - 3.7/2.76 kW

Amps @ 240/208V: 17.5 Amps

Power supply location: Back-right bottom

ACCESSORIES INCLUDED:

1 grid with backstop

1 insert grid

2 enamelled trays (20mm)



SFU6302TVX

60 CM (APPROX. 24") "CLASSIC" DESIGN
MULTIFUNCTION OVEN, STAINLESS STEEL AND SMART-BLACK GLASS



"Classic" Design

Multifunction oven with 12 cooking modes



Stainless steel and Smart-black glass finish
Fingerprint-proof stainless steel
Ergonomic control knobs

Large LCD display

20 automatic cooking program

Automated oven switch-off when door is open
Electronic temperature control

True European convection

Adjustable temperature 87 - 536° F
Rapid preheat

Vapor-Clean system

Soft Close door

EverClean enamel cavity for quick and easy cleaning

5 rack positions

Double-insulated cavity

Air-cooled door

Ceramic catalyst fume control

Child-safe control lock

Safe-touch cooling

Triple-glazed removable door

Quickly-removable, easy-to-clean inner door glass

2 Halogen lights (2 x 40 W)

Oven capacity: 2.8 cu ft

Interior dimensions: W 18,11" x H 14,17" x 16,73"

Voltage rating: 240/120V 60 Hz

Connected load (nominal power): 3 kW

Amps: 14 Amps

ACCESSORIES INCLUDED:

1 telescopic guide rail (total extraction)

1 grid with backstop

1 insert grid

1 enamelled tray (20mm)

1 enamelled tray (40mm)



SFU7302TVX

SFU6302TVX

For technical drawing in metric, see page 177



CLASSIC

OVENS

SFU6302TVX

SOU330X1

SELF-CLEANING

76 CM (30") "CLASSIC" ELECTRIC MULTIFUNCTION OVEN
STAINLESS STEEL AND SMART-BLACK GLASS



"Classic" Design

Multifunction oven with 11 cooking modes



Stainless steel and Smart-black glass finish
Fingerprint-proof stainless steel
Ergonomic control knobs

Electronic display

Electronic temperature control

True European Double convection

Adjustable temperature 87 - 554° F
Fast preheat cycle (8 to 12 minutes)

Self-Cleaning

Door lock during self cleaning
Automated oven switch-off when door is open
6 rack positions
Double-insulated cavity
Air-cooled door
Safe-touch cooling
Triple-glazed removable door
2 Halogen lights (3 x 20 W)

Oven capacity: 4.34 cu ft
Interior dimensions: W 24" x H 16,15" x D 16,34"
Voltage rating: 240/208V 60 Hz
Connected load (nominal power): 240/208V -
3,535 W
Amps @ 240/208V: 15.6 Amps

ACCESSORIES INCLUDED:

- 2 grids with back and side stops
- 1 insert grid
- 1 enamel tray
- 1 telescopic guide
- 1 meat probe

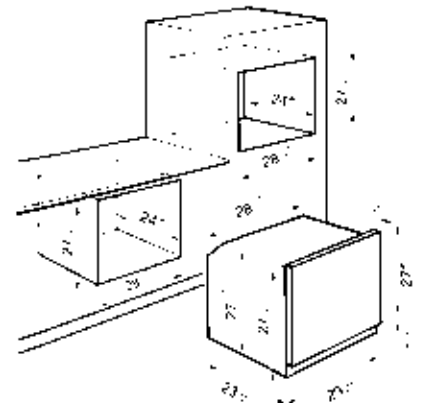

For technical drawing in metric, see page 177



CLASSIC

OVENS

DOU330X1

SELF-CLEANING

76 CM (30") "CLASSIC" ELECTRIC MULTIFUNCTION DOUBLE OVEN, STAINLESS STEEL AND SMART-BLACK GLASS

DOUBLE OVEN WITH SMART-BLACK GLASS FINISH



The "Smart-Black" glass is an elegant glass type that appears completely opaque when the oven is off, and becomes transparent when the oven is on.



MAIN AND SECONDARY OVEN

"Classic" Design

Two multifunction ovens, each with 10 cooking modes (including warming and dehydrate) + self-cleaning cycle

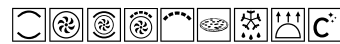

- Fingerprint-proof stainless steel
- Ergonomic control knobs
- Touch control panel to access secondary menu
- Electronic display
- True European double convection
- Fast preheat cycle (8 to 12 minutes)
- Adjustable temperature: 86° - 554° F
- Automated oven switch-off when door is open
- Self-cleaning
- Sabbath mode
- Child safety locks
- 6 rack positions
- 1 telescopic guide

ACCESSORIES INCLUDED (MAIN AND SECONDARY OVEN):

- 1 grid insert for tray
- 3 grid tops
- 1 telescopic guide
- 1 enameled tray
- 1 meat probe

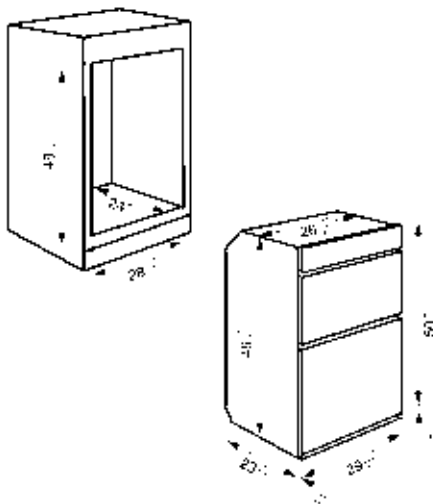

- Oven capacity: 4.34 cu ft
- Interior dimensions: W 24" x H 16 1/8" x 16 5/16"
- Concealed bake element
- Voltage rating: 240/208V 60Hz
- Connected load (nominal power): 240/208V: 32.4/33.8 Amps
- Power supply location: center-top

For technical drawing in metric, see page 177

SF399XU

60 CM (APPROX. 24") "CLASSIC" ELECTRIC MULTIFUNCTION OVEN, STAINLESS STEEL AND SMART-BLACK GLASS



"Classic" Design

Multifunction oven with 10 cooking modes



Fingerprint-proof stainless steel

Ergonomic control knobs

Digital analog LED electronic clock/timer

EverClean enamel cavity for quick and easy cleaning

Automated oven switch-off when door is open

5 rack positions

True European convection

Adjustable temperature: 122° - 490° F

Vapor-Clean system

Air-cooled door

Triple-glazed removable door

Quickly removable, easy-to-clean inner door glass

2 Halogen lights (2 x 20 W)

Roof liner

Oven capacity: 2.8 cu ft

Inner dimensions: W 17½" x H 14¹¹/₆₄" x D 16¾"

Bake element 2.2 kW

Broil element 2.7 kW

Convection element 2.0 kW

Voltage Rating: 240/120V 60Hz

Connected load (nominal power) 3.5 kW

Amps 240/120V: 14 Amps

Power supply location: back right bottom

ACCESSORIES INCLUDED:

1 baking tray

1 wire rack with tray insert

1 wire rack with backstop

OPTIONS:

PRTX Pizza stone with handles

PALPZ Pizza shovel with fold away handle



PRTX



PALPZ

A truly Italian pizza cooked in only 4-5 minutes! With the oven set at 490°F, the pizza stone allows you to cook the pizza rapidly.

CLASSIC

OVENS

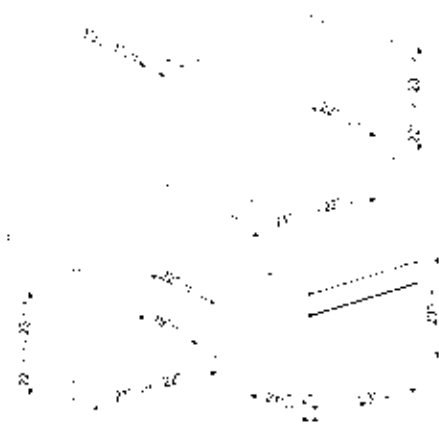

For technical drawing in metric, see page 177

COMPACT OVENS AND COFFEE MACHINES

Small space appliance engineering meets multi-tasking cooking technologies to create state-of-the-art kitchen appliances that truly deliver fine cuisine and delightful beverages right at home.



COMPACT OVENS
COFFEE MACHINES

COMPACT APPLIANCES

personality and style

SMEG offers design-coordinated compact appliances with multiple functions for your kitchen, allowing for the creation of a small, efficient work area for the cook that has an eye for personality and style.

COMBINATION STEAM OVEN, A HEALTHY LIFESTYLE

The combination steam oven offers a variety of cooking solutions in one appliance for maximum user flexibility. It can be used either as a steam oven, or as a traditional oven, or alternatively the two methods can be combined allowing the user to cook the tastiest dishes in the healthiest way possible.

The oven is also equipped with a broiler to brown food at the end of the cooking time and give it a delicious crispy finish. Steaming is also ideal for cooking different foods simultaneously that require different cooking times, because the natural ingredients absorb only enough water as is necessary.



INNOVATIVE WATER FILLING SYSTEM

The water is drawn in through a flexible tube which disappears into the cavity when it is not used. This discrete system has no impact on the volume of the cavity or the oven's interior or exterior aesthetics, meaning that the SMEG combi-steam oven has one of the largest compact cavities and is one of the best looking ovens on the market.



SMEG offers a warming drawer which circulates warm air in order to heat up plates quickly and evenly. The base of the drawer is fitted with a non-slip mat to prevent plates and dishes from sliding when the drawer is opened or closed.

COFFEE MACHINES

a perfect beginning

SMEG offers built-in machines to complete your kitchen, to make professional espresso and cappuccino in the comfort of your home. The built-in coffee machine utilizes a 15 bar pressure pump. This maximizes the flavor extraction from the coffee beans, optimizing the pour, resulting in a delightful crema for a perfect cup of coffee every time.



You can use either **ready-ground coffee** or **beans** (with an adjustable grinding function at 13 levels) and prepare **one or two cups** at the same time.



All coffee machines featured in our current range have **clear and easy-to-use displays**. Some models feature touch control displays with large, clear, intuitive menus.



5 adjustable coffee lengths, **5 levels of coffee strength** (Extra-Light, Light, Medium, Strong & Extra Strong) and **3 adjustable coffee temperatures**.



COMPACT OVENS
COFFEE MACHINE



An **accurate cleaning process** starts every time the machine switches on or switches off to guarantee maximum performance.



All SMEG coffee machines have an **automatic cappuccino-maker** that will whisk milk into a delicate foam directly into the cup.

SFU4104VCS

COMBI STEAM

60 CM (APPROX. 24") LINEA DESIGN
 BUILT-IN STEAM COMBINATION OVEN, MYSTIC
 GRAY GLASS

**SFU4104MCS**

SPEED OVEN

60 CM (APPROX. 24") LINEA DESIGN
 BUILT-IN SPEED OVEN WITH 1000W MICROWAVE,
 MYSTIC GRAY GLASS



A trim kit for installation in wider wall cabinets above a 30" oven is available. The kit consists of two Mystic Gray glass bars that allow the speed oven to reach 30 inch width.

Linea Design

Steam combination oven with 14 cooking modes

**Touch screen controls**

Mystic Gray glass finish

Color TFT touch screen display

50 automatic cooking programs

10 customizable recipes

Electronic temperature control

True European convection (combinable with steam oven)

Adjustable temperature: 87° - 482° F

Steam cooking (combinable with convection oven)

Steam stops when door is open

Rapid preheat

Vapor-Clean system

EverClean enamel cavity for quick and easy cleaning

Automated oven switch-off when door is open

3 rack positions

Soft Close door

Double-insulated cavity

Air-cooled door

Ceramic catalyst fume control

Child-safe control lock

Safe-touch cooling

Quadruple-glazed removable door

Quickly removable, easy-to-clean inner door glass

Child-safe control lock

1 Halogen bulb (1 x 40 W)

Oven capacity: 1.77 cu ft

Water tank capacity: 0.32 gal.

Voltage rating: 120/240V 60 Hz

Connected load (nominal power): 3.0 kW

Amps 240 V: 15 Amps

ACCESSORIES INCLUDED:

- 1 telescopic guide rail (partial extraction)
- 1 grid with back and side stop
- 1 insert grid
- 1 enamelled deep tray (40mm)
- 1 stainless steel tray (20mm)
- 1 stainless steel perforated deep tray (40mm)
- 1 beaker
- 1 sponge/descaler

Linea Design

Microwave combination oven with 13 cooking modes

**Touch screen controls**

Mystic Gray glass finish

Color TFT touch screen display

50 automatic cooking programs

10 customizable recipes

Electronic temperature control

True European convection (combinable with microwave)

Adjustable temperature: 87° - 482° F

End-of-cooking acoustic alarm

Time-setting options: Start & Stop

Delay start and automatic end cooking

Minute minder

Rapid preheat

EverClean enamel cavity for quick and easy cleaning

Automatic oven/microwave switch-off when door is open

3 rack positions

12 5/8" size glass turntable

Cooling fan

Defrost programmed by weight or by time

Child-safe control lock

Microwave screen protection

1 Halogen light (illuminates when door is opened)

(1x 20 W)

Oven capacity: 1.77 cu ft

Microwave power: 2,000 W

Microwave effective power: 1,000 W

Voltage rating: 120/240V 60 Hz

Connected load (nominal power): 3.00 kW

Amps 240 V: 16 Amps

ACCESSORIES INCLUDED:

- 1 telescopic guide rail (partial extraction)
- 1 grid with back and side stop
- 1 insert grid
- 1 glass tray

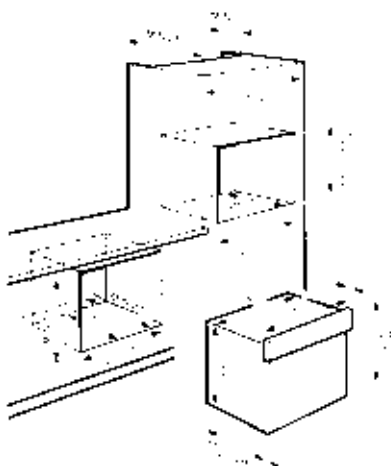

For technical drawing in metric, see page 177



LINEA

COMPACT OVENS

SFU6104TVS (left)
with SFU4104MCS
atop CPRU115S (right)

CPRU115S

24" (60 CM), LINEA DESIGN WARMING DRAWER, MYSTIC GRAY GLASS



Linea Design

Mystic Gray glass finish

Push opening

Anti-slip mat

Inner control knob

Adjustable temperature: 86° - 176° F

On/off pilot lamp

Maximum weight allowed above the drawer: 187 lbs.

Maximum weight allowed inside the drawer: 33 lbs.

Power heating element: 400 W

Dimensions: W 23 ²⁷/₆₄" x H 5 ²³/₆₄" x D 21 ⁵⁹/₆₄"

Voltage rating: 120V/50-60 Hz

COORDINATES WITH:

Compact oven, Linea Design aesthetic

CPRU130S

30" (76 CM), LINEA DESIGN WARMING DRAWER, MYSTIC GRAY GLASS

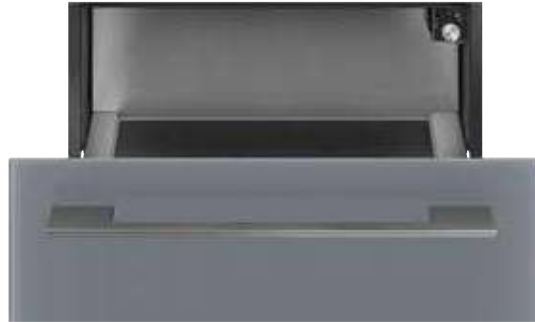

Linea Design

Mystic Gray glass finish

Handle opening

Anti-slip mat

Inner control knob

Adjustable temperature: 86° - 167° F

Adjustable timer from 0 to 240 minutes with automatic switch-off

Delay timer up to 10 h

On/off pilot lamp

Maximum weight allowed above the drawer: 187 lbs.

Maximum weight allowed inside the drawer: 33 lbs.

Power heating element: 800 W

Dimensions: W 28,15" x H 10,04" x D 24,4"

Voltage rating: 120V/50-60 Hz

COORDINATES WITH:

30" oven, Linea Design aesthetic

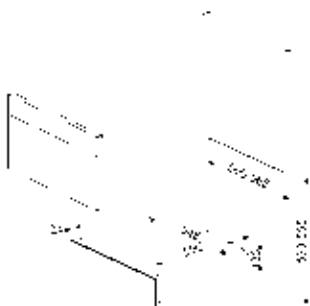

For technical drawing in metric, see page 178

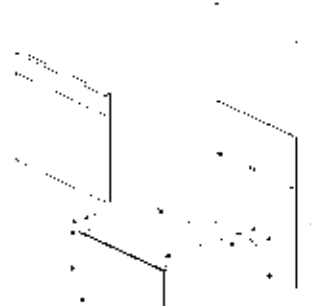

For technical drawing in metric, see page 178

CMSU4104S

60 CM (APPROX. 24"), FULLY-AUTOMATIC
COFFEE MACHINE WITH MILK FROTHER,
MYSTIC GRAY GLASS



Linea Design

Touch screen controls

Mystic Gray glass finish

Colour TFT soft touch screen display

Coffee function: regular or double coffee

(1 or 2 cups at the same time)

Automatic cappuccino maker with separate tank for milk

Hot water function for tea or other hot drinks

Rinsing function and descaling function

Coffee intensity adjustable (5 levels):

Extra-Light, Light, Medium, Strong, Extra-Strong

Coffee length adjustable (5 levels)

Adjustable coffee temperature (3 levels)

Adjustable coffee grinder (13 levels)

Programmable automatic switch-on

Automatic energy saving stand-by

Programmable multi-language display

Coffee bean container

Separate container for ground coffee

Removable water tank

Removable container for coffee grounds

Frothing nozzle for cappuccino

Adjustable coffee dispenser (for tall or short cups)

Drip tray

4 lights

Telescopic guides with Soft Close

Semi-pro stainless steel conical grinder

Stainless steel 0,5 L thermal carafe with autoclean system

Capacity of water tank: 81 oz

Capacity of coffee bean container: 0.77 lbs

Pump pressure: 217 psi

Connected rating (nominal power): 1,350 W -
11 Amps

Tension/frequency: 120V 60 Hz

Pump pressure: tension/frequency: 120V 60 Hz

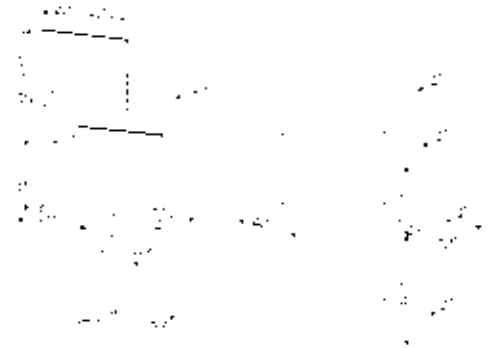

For technical drawing in metric, see page 178

SCU45VCS1

COMBI STEAM

60 CM (APPROX. 24") LINEA DESIGN
BUILT-IN STEAM COMBINATION OVEN,
SUPERSILVER GLASS



Linea Design

10 cooking modes



Supersilver glass finish
Ergonomic control knobs
Stainless steel cavity
Digital LED display
True European convection (combinable with steam oven)
Pizza cooking function
Steam cooking (combinable with convection oven)
Steam stops when door is open
Adjustable temperature: 105° - 430° F
Child-safe control lock
1 Halogen bulb (1x 25 W)

Oven capacity: 1.34 cu ft
Water tank capacity: 0.32 gal

Voltage rating: 220V 60 Hz
Connected load (nominal power): 2.7 kW
Amps 240V: 12.3 Amps

ACCESSORIES INCLUDED:

1 steel tray
1 large grid
1 deep perforated steel tray
1 beaker
1 sponge/descaler

OPTIONS:

Please note that this oven may be installed in a wall cabinet that is a minimum of 22" wide.
A trim kit for an installation in a wider cabinet above a 30" oven is available (product code KIT457OS).

SCU45MCS1

SPEED OVEN

60 CM (APPROX. 24") LINEA DESIGN
BUILT-IN SPEED OVEN WITH 1000W MICROWAVE,
SUPERSILVER GLASS



Linea Design

10 cooking modes

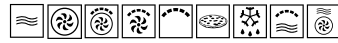

Supersilver glass finish
Ergonomic control knobs
Stainless steel cavity
Digital LED display
Time-setting options: Start & Stop
End-of-cooking acoustic alarm
Automatic oven/microwave switch-off when door is open
True European convection cooking (combinable with microwave)
12 3/8" size glass turntable
Adjustable temperature: 122° - 428°F
Cooling fan
Defrost programmed by weight or by time
Microwave pizza cooking function
Child-safe control lock
Microwave screen protection
1 Halogen light (illuminates when door is opened) (1x 20 W)

Oven capacity: 1.34 cu ft
Microwave power: 1,850W
Microwave effective power: 1,000W

Voltage rating: 220V 60Hz
Connected load (nominal power): 3.40 kW
Amps 240V: 16 Amps

ACCESSORIES INCLUDED:

1 large grid
1 glass tray
1 special crisp plate

OPTIONS:

Please note that this oven may be installed in a wall cabinet that is a minimum of 22" wide.
A trim kit for an installation in a wider cabinet above a 30" oven is available (product code KIT457OS).

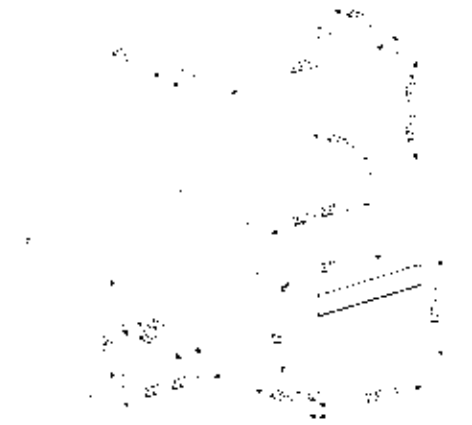

SCU45VCS1

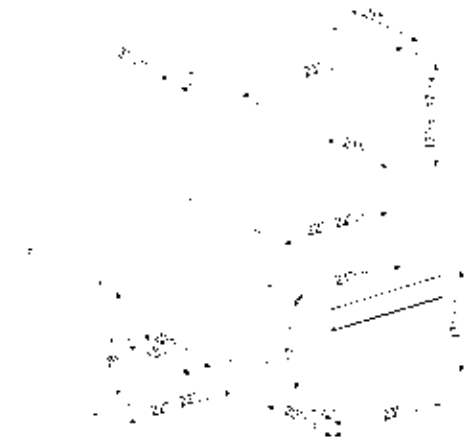

SCU45MCS1

For technical drawing in metric, see page 177

CTU15S

FOOD AND DISH WARMING DRAWER FOR
COMPACT OVENS, 24" (60 CM),
SUPERSILVER GLASS



Linea Design

Supersilver Glass finish
Handle opening
Anti-slip mat
Electronic touch controls
Adjustable temperature: 86° - 176° F
Adjustable timer from 0 to 240 minutes with
automatic switch-off
Delay timer up to 9 h, 50 min
On/off pilot lamp
Maximum weight allowed above the drawer: 187 lbs
Maximum weight allowed inside the drawer: 33 lbs
Power heating element: 400 W
Dimensions: W 23 ²⁷/₆₄" x H 5 ²³/₆₄" x D 21 ⁵⁹/₆₄"
Voltage rating: 120V/50-60 Hz

COORDINATES WITH:

Compact oven, Linea Design aesthetic

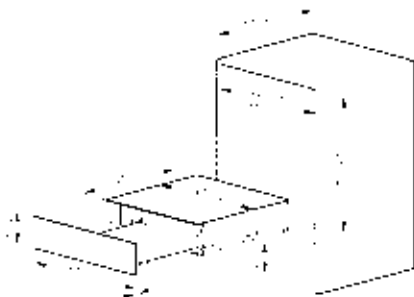

For technical drawing in metric, see page 177

OTR111SU

OVER-THE-RANGE MICROWAVE, 30"
SUPERSILVER GLASS



Linea Design

Supersilver Glass finish
Simple and multi-stage microwave cooking
Speedy cooking
Defrost functions: by weight, by time
Timer function
Functions: popcorn, baked potato, beverage, and reheat
Child-safe control lock
Hood function
2 halogen hood lights
Touchpad control with white LED display
Microwave power: 1,000 W
Cavity capacity: 1.1 cu ft
Glass turntable (diameter in.) 13 ⁵/₈"

Max setting 300 CFM
Noise level: 49 dB(A)
Multi-speed vent
3 venting options: roof, wall, room
2 ventilation filters

Connected load (nominal power): 1,550 W
Circuit breaker (A): 15 Amps
Voltage rating: 120V 60Hz
Overall appliance dimensions (HxWxD) (in):
16 ¹/₂" (41,9 cm) x 29 ⁷/₈" (76 cm) x 15 ³/₈" (39 cm)

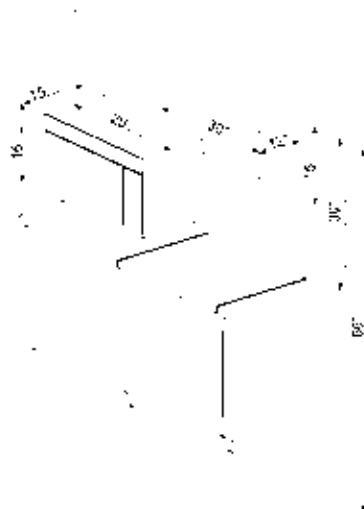

For technical drawing in metric, see page 178

CMSCU451S

60 CM (APPROX. 24"), FULLY-AUTOMATIC
COFFEE MACHINE WITH MILK FROTHER,
SUPERSILVER GLASS



Linea Design

Supersilver glass
Multilanguage LCD display
Coffee function: regular or double coffee
(1 or 2 cups at the same time)
Automatic cappuccino maker with separate tank for milk
Hot water function for tea or other hot drinks
Rinsing function and descaling function
Coffee intensity adjustable (5 levels):
Extra-Light, Light, Medium, Strong, Extra-Strong
Coffee length adjustable (3 levels):
Espresso (Short), Espresso, Medium, Long
Adjustable coffee temperature (3 levels)
Adjustable coffee grinder
Programmable automatic switch-on
Automatic energy saving stand-by
Programmable multi-language display
Coffee bean container
Separate container for ground coffee
Removable water tank
Removable container for coffee grounds
Frothing nozzle for cappuccino
Adjustable coffee dispenser (for tall or short cup)
Drip tray
2 lights
Telescopic guides

Capacity of water tank: 60 oz
Capacity of coffee bean container: 7 3/4"
Pump pressure: 217 psi
Connected rating (nominal power): 1,350 W -
11 Amps
Tension/frequency: 120V 60 Hz
Pump pressure, tension/frequency: 120V 60 Hz

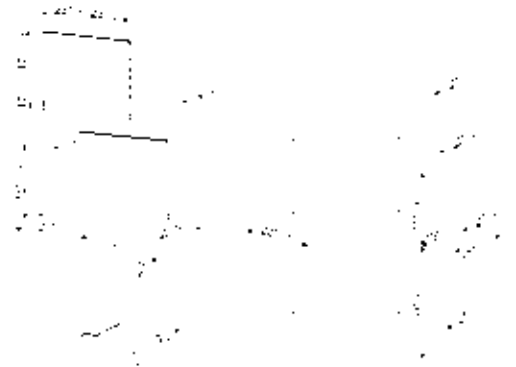

For technical drawing in metric, see page 178



CLASSIC

COMPACT OVENS

SF112U (left)
with CMSCU451S
atop CTU15S (left)

SFU4302VCX

COMBI STEAM

60 CM (APPROX. 24") BUILT-IN COMBINATION STEAM OVEN, FINGERPRINT-PROOF STAINLESS STEEL

**SFU4302MCX**

SPEED OVEN

60 CM (APPROX. 24") "CLASSIC" BUILT-IN SPEED OVEN WITH 1000W MICROWAVE, FINGERPRINT-PROOF STAINLESS STEEL



A trim kit for installation in wider wall cabinets above a 30" oven is available. (product code KIT330X) The kit consists of two stainless steel bars that allow the speed oven to reach 30inch width.

SMEG offers a warming drawer which circulates warm air in order to heat up plates quickly and evenly. The base of the drawer is fitted with a non-slip mat to prevent plates and dishes from sliding when the drawer is opened or closed.

**"Classic" Design**

Steam combination oven with 14 cooking modes



Fingerprint-proof stainless steel finish

Ergonomic control knobs

Compact LCD display

20 automatic cooking program

Electronic temperature control

True European convection (combinable with steam oven)

Adjustable temperature: 87° - 482° F

Steam cooking (combinable with convection oven)

Steam stops when door is open

Rapid preheat

Vapor-Clean system

EverClean enamel cavity for quick and easy cleaning

Automated oven switch-off when door is open

3 rack positions

Soft Close door

Double-insulated cavity

Air-cooled door

Ceramic catalyst fume control

Child-safe control lock

Safe-touch cooling

Quadruple-glazed removable door

Quickly removable, easy-to-clean inner door glass

Child-safe control lock

1 Halogen bulb (1x 40 W)

Oven capacity: 1.77 cu ft

Water tank capacity: 0.32 gal

Voltage rating: 120/240V 60 Hz

Connected load (nominal power): 3.0 kW

Amps 240V: 15 Amps

ACCESSORIES INCLUDED:

- 1 telescopic guide rail (partial extraction)
- 1 grid with back and side stop
- 1 insert grid
- 1 enamelled deep tray (40mm)
- 1 stainless steel tray (20mm)
- 1 stainless steel perforated deep tray (40mm)
- 1 beaker
- 1 sponge/descaler

OPTIONS:

Kit 330X - Trim kit to reach 30" width.

"Classic" Design

Microwave combination oven with 13 cooking modes



Fingerprint-proof stainless steel finish

Ergonomic control knobs

Compact LCD display

20 automatic cooking program

Electronic temperature control

True European convection (combinable with microwave)

Adjustable temperature: 87° - 482° F

End-of-cooking acoustic alarm

Time-setting options: Start & Stop

Delay start and automatic end cooking

Minute reminder

Rapid preheat

EverClean enamel cavity for quick and easy cleaning

Automatic oven/microwave switch-off when door is open

3 rack positions

12 5/8" size glass turntable

Cooling fan

Defrost programmed by weight or by time

Child-safe control lock

Microwave screen protection

1 Halogen light (illuminates when door is opened)

(1x 20 W)

Oven capacity: 1.77 cu ft

Microwave power: 2,000 W

Microwave effective power: 1,000 W

Voltage rating: 120/240V 60 Hz

Connected load (nominal power): 3.0 kW

Amps 240 V: 16 Amps

ACCESSORIES INCLUDED:

- 1 telescopic guide rail (partial extraction)
- 1 grid with back and side stop
- 1 insert grid
- 1 glass tray

OPTIONS:

Kit 330X - Trim kit to reach 30" width.

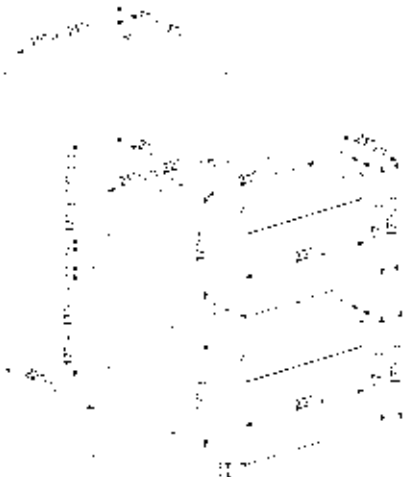

For technical drawing in metric, see page 177



CLASSIC

OVENS

SFU4302VCX
KIT330X
SOU330X1

SU45VCX1

COMBI STEAM

60 CM (APPROX. 24") "CLASSIC" DESIGN
BUILT-IN STEAM COMBINATION OVEN,
FINGERPRINT-PROOF STAINLESS STEEL



"Classic" Design

10 cooking modes

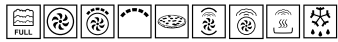

Fingerprint-proof stainless steel finish

Ergonomic control knobs

Stainless steel cavity

Digital LED display

True European convection (combinable with steam oven)

Pizza cooking function

Steam cooking (combinable with convection oven)

Steam stops when door is open

Adjustable temperature: 105° - 430° F

Child-safe control lock

1 Halogen bulb (1x 25 W)

Oven capacity: 1.34 cu ft

Water tank capacity: 0.32 gal

Voltage rating: 220V 60 Hz

Connected load (nominal power): 2.7 kW

Amps 240V: 12.3 Amps

ACCESSORIES INCLUDED:

- 1 steel tray
- 1 large grid
- 1 deep perforated steel tray
- 1 beaker
- 1 sponge/descaler

OPTIONS:

Please note that this oven may be installed in a wall cabinet that is a minimum of 22" wide.
A trim kit for an installation in a wider cabinet above a 30" oven is available (product code KIT4570X).

SU45MCX1

SPEED OVEN

60 CM (APPROX. 24") "CLASSIC" DESIGN
BUILT-IN SPEED OVEN WITH 1000W MICROWAVE,
FINGERPRINT-PROOF STAINLESS STEEL



"Classic" Design

10 cooking modes

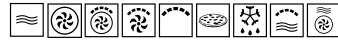

Fingerprint-proof stainless steel finish

Ergonomic control knobs

Stainless steel cavity

Digital LED display

Time-setting options: Start & Stop

End-of-cooking acoustic alarm

Automatic oven/microwave switch-off when door is open

True European convection cooking (combinable with microwave)

12 3/8" size glass turntable

Adjustable temperature: 122° - 428°F

Cooling fan

Defrost programmed by weight or by time

Microwave pizza cooking function

Child-safe control lock

Microwave screen protection

1 Halogen light (illuminates when door is opened)

(1x 20 W)

Oven capacity: 1.34 cu ft

Microwave power: 1,850W

Microwave effective power: 1,000W

Voltage rating: 220V 60Hz

Connected load (nominal power): 3.40 kW

Amps 240V: 16 Amps

ACCESSORIES INCLUDED:

- 1 large grid
- 1 glass tray
- 1 special crisp plate

OPTIONS:

Please note that this oven may be installed in a wall cabinet that is a minimum of 22" wide.
A trim kit for an installation in a wider cabinet above a 30" oven is available (product code KIT4570X).

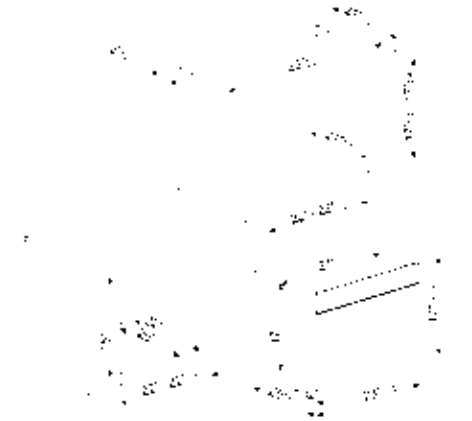

SU45VCX1

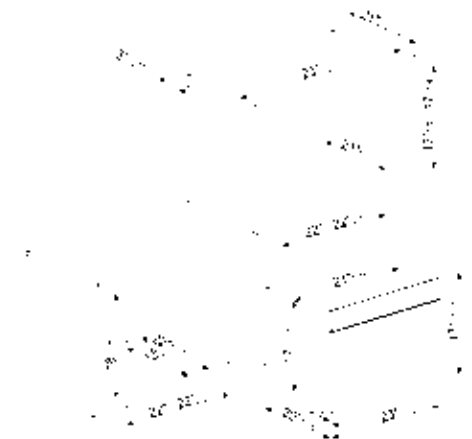

SU45MCX1

For technical drawing in metric, see page 177

CPRU315X

FOOD AND DISH WARMING DRAWER FOR COMPACT OVENS, 24" (60 CM), FINGERPRINT-PROOF STAINLESS STEEL



"Classic" Design

Push opening
Anti-slip mat
Inner control knob
Adjustable temperature: 86° - 176° F
On/off pilot lamp
Maximum weight allowed above the drawer: 187 lbs.
Maximum weight allowed inside the drawer: 33 lbs.
Power heating element: 400 W
Dimensions: W 23 27/64" x H 5 23/64" x D 21 59/64"
Voltage rating: 120V 50-60 Hz

COORDINATES WITH:

Compact oven, "Classic" aesthetic



CPRU330X

FOOD AND DISH WARMING DRAWER FOR OVENS, 30" (76 CM), FINGERPRINT-PROOF STAINLESS STEEL



"Classic" Design

Handle opening
Anti-slip mat
Inner control knob
Adjustable temperature: 86° - 176° F
Adjustable timer from 0 to 240 minutes with automatic switch-off
Delay timer up to 10 h
On/off pilot lamp
Maximum weight allowed above the drawer: 187 lbs.
Maximum weight allowed inside the drawer: 33 lbs.
Power heating element: 800 W
Dimensions: W 28.15" x H 10.04" x D 24.4"
Voltage rating: 120V 50-60 Hz

COORDINATES WITH:

30" oven, "Classic" aesthetic



CTPU15X

FOOD AND DISH WARMING DRAWER FOR COMPACT OVENS, 24" (60 CM), FINGERPRINT-PROOF STAINLESS STEEL



"Classic" Design

Push opening
Anti-slip mat
Electronic touch controls
Adjustable temperature: 86° - 176° F
Adjustable timer from 0 to 240 minutes with automatic switch-off
Delay timer up to 9 h, 50 min
On/off pilot lamp
Maximum weight allowed above the drawer: 187 lbs.
Maximum weight allowed inside the drawer: 33 lbs.
Power heating element: 400 W
Dimensions: W 23 27/64" x H 5 23/64" x D 21 59/64"
Voltage rating: 120V 50-60 Hz

COORDINATES WITH:

Compact oven, "Classic" aesthetic

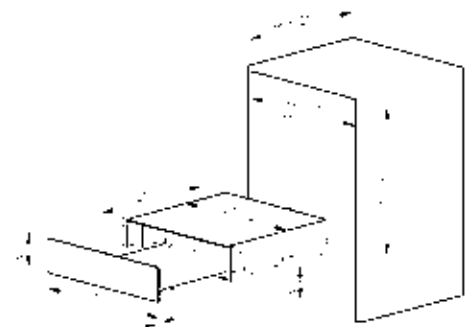
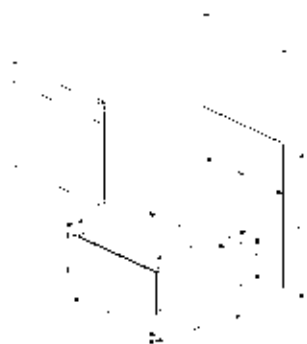
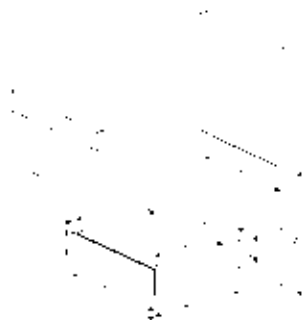

For technical drawing in metric, see page 178

FMIU020X

MICROWAVE

OTR316XU

60 CM (APPROX. 24") BUILT-IN MICROWAVE,
FINGERPRINT-PROOF STAINLESS STEEL

30" OVER-THE-RANGE MICROWAVE, MICROWAVE/VENT HOOD
FINGERPRINT-PROOF STAINLESS STEEL

**"Classic" Design**

Microwave with grill, multiple programs



Fingerprint-proof stainless steel finish

8 automatic programs

Automatic defrosting by time or weight

Stainless steel interior cavity

Lateral opening door

Single LED display

Quick start option

Child-safe control lock

9 3/4" turntable

Microwave power: 800 W

Broil element: 1000 W

20 W internal light

Dimensions: W 23.4" x H 13.5" x D 15"

Voltage rating 120V 60Hz

Connected load (nominal power): 1,350 W

Amps 120 V - 11 Amps

ACCESSORIES INCLUDED:

Frame kit for built-in installation

1 grid

"Classic" Design

Fingerprint-proof stainless steel finish

Simple and multi-stage microwave cooking

Speedy cooking

Defrost functions: by weight, by time

Timer function

Functions: popcorn, baked potato, beverage and reheat

Child-safe control lock

Hood function

2 halogen hood lights

Touchpad control with white LED display

Microwave power: 1,000 W

Cavity capacity: 1.6 cu ft

13 5/8" turntable

Max setting 300 CFM

Noise level: 49dB(A)

Multi-speed vent

3 venting options: roof, wall, room

2 ventilation filters

Connected load (nominal power): 1,550 W - 15 Amps

Voltage rating: 120V 60Hz

Overall appliance dimensions (HxWxD) (in):

16 1/2" (41,9cm) x 29 7/8" (76cm) x 15 3/8" (39cm)

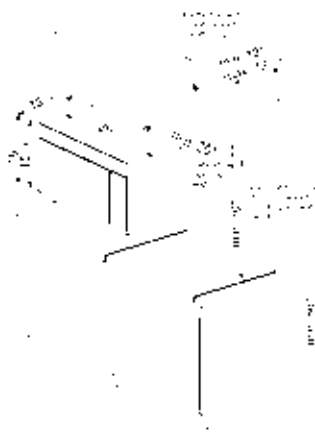
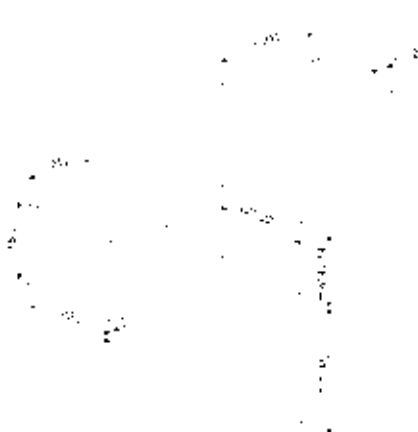



CLASSIC

OVENS

CMSU4303X

60 CM (APPROX. 24"), FULLY-AUTOMATIC COFFEE MACHINE WITH MILK FROTHER, FINGERPRINT-PROOF STAINLESS STEEL



"Classic" Design

Fingerprint-proof stainless steel finish
Colour TFT soft touch-screen display
 Coffee function: regular or double coffee (1 or 2 cups at the same time)
 Automatic cappuccino maker with separate tank for milk
 Hot water function for tea or other hot drinks
 Rinsing function and descaling function
 Coffee intensity adjustable (5 levels): Extra-Light, Light, Medium, Strong, Extra-Strong
 Coffee length adjustable (5 levels)
 Adjustable coffee temperature (3 levels)
 Adjustable coffee grinder (13 levels)
 Programmable automatic switch-on
 Automatic energy saving stand-by
 Programmable multi-language display
 Coffee bean container
 Separate container for ground coffee
 Removable water tank
 Removable container for coffee grounds
Frothing nozzle for cappuccino
 Adjustable coffee dispenser (for tall or short cup)
 Drip tray
 4 lights
 Telescopic guides with Soft Closing
 Semiprofessional stainless steel conical grinder
Stainless steel 0,5 L thermal carafe with autoclean system
 Capacity of water tank: 81 oz
 Capacity of coffee bean container: 0.77 lbs
 Pump pressure: 217 psi
 Connected rating (nominal power): 1,350 W - 11 Amps
 Tension/frequency: 120V 60 Hz
 Pump pressure: tension/frequency: 120V 60 Hz

CMSU6451X

60 CM (APPROX. 24"), FULLY-AUTOMATIC COFFEE MACHINE WITH MILK FROTHER, FINGERPRINT-PROOF STAINLESS STEEL



"Classic" Design

Fingerprint-proof stainless steel finish
 Multilanguage LCD display
 Coffee function: regular or double coffee (1 or 2 cups at the same time)
 Automatic cappuccino maker with separate tank for milk
 Hot water function for tea or other hot drinks
 Rinsing function and descaling function
 Coffee intensity adjustable (5 levels): Extra-Light, Light, Medium, Strong, Extra-Strong
 Coffee length adjustable (3 levels): Espresso (Short), Espresso, Medium, Long
 Adjustable coffee temperature (3 levels)
 Adjustable coffee grinder
 Programmable automatic switch-on
 Automatic energy saving stand-by
 Programmable multi-language display
 Coffee bean container
 Separate container for ground coffee
 Removable water tank
 Removable container for coffee grounds
Frothing nozzle for cappuccino
 Adjustable coffee dispenser (for tall or short cup)
 Drip tray
 2 lights
 Telescopic guides
 Capacity of water tank: 60 oz
 Capacity of coffee bean container: 7 3/4"
 Pump pressure: 217 psi
 Connected rating (nominal power): 1,350 W - 11 Amps
 Tension/frequency: 120V 60 Hz
 Pump pressure, tension/frequency: 120V 60 Hz

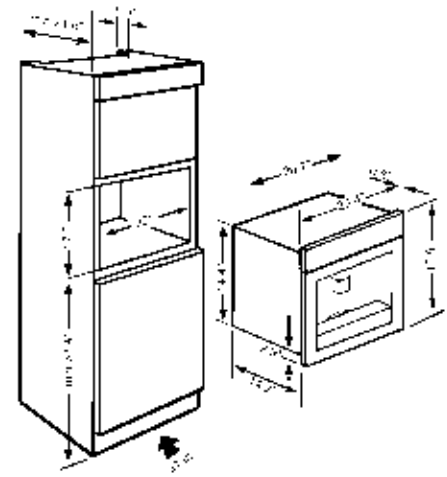

For technical drawing in metric, see page 178



CLASSIC

COFFEE MACHINES

CMSU4303X atop
CPRU3 15X (left)
with SFU4302MCX
atop CPRU3 15X (right)

WINE COOLERS

Italy has the largest and most diversified wine production in the world. The charm of the wine world and the importance of its preservation have inspired SMEG to develop this range of wine coolers.

Designed for those who love to entertain or have a real passion for wine, these are must-have kitchen appliances. Wine is stored at optimum temperatures and ideal humidity conditions to ensure it matures properly, so you can enjoy your favorite bottle to its fullest.



WINE COOLERS

CVIU318RX
atop CPS315X

WINE COOLERS

wines stored with the utmost care

SMEG presents wine coolers developed for conserving fine wines and impressing guests. Equipped with spacious shelves finished in untreated wood, they store different shapes and sizes of bottles, from classic Bordeaux blends to Magnums.



PERFECT PRESERVATION

Finished with UV-ray resistant glass, protecting against harmful UV rays which can damage the quality of the wine, and a motor/ compressor designed with particular care, the wine cooler protects bottles from harmful vibrations.

SHELVES

Made from Slavonian Oak, used traditionally by Italian winemakers to make barrels as it is known for its tight grain, low aromatics and medium-level tannins. Some shelves are telescopic, so wines can be removed with ease, safely and conveniently.

CONTROLS ON THE EXTERIOR

The touch control display on the glass door allows you to set temperature and humidity parameters without the door opening. It is possible to independently adjust the humidity level, as well as the temperature in order to ensure the appropriate environment for different bottles. The temperature can be set between 41° and 68°F, guaranteeing optimal conditions for each bottle of wine.

Under-counter models can **hold up to 38 wine bottles**.



TAILOR-MADE PROFESSIONAL CONSERVATION

a wine enthusiast's dream

The new SMEG wine coolers use the latest technology to correctly store and age wine. The materials used have been carefully selected, in cooperation with expert sommeliers, who have helped create a range of excellent technical and high-quality products.

SMEG wine coolers are entirely made in Italy, as the result of the know-how and attention to detail that only an Italian company with a long and consolidated experience can guarantee.



HUMIDITY CONTROL

In order to preserve wine for a long time, it's essential to maintain the correct level of humidity within the wine cooler. If the level of humidity is lower than 50%, the wine cooler is too dry, and this can cause the corks to become brittle, and trigger wine oxidation. On the other hand, a level of humidity higher than 85% can cause the formation of mold on the labels, which can spread to the corks, and the wine cooler itself. With a level of humidity between 60% and 80%, SMEG wine coolers guarantee optimal preservation of wine.

LIGHT

Solar light, and UV rays in-particular, can alter the wines (organoleptic structure), ruining its balance and flattening its scent; red wine loses its tone, while white wine takes on a yellowish color.

Thanks to the SMEG wine coolers "Eclipse" black-glass technology, the wine is perfectly shielded. The layered glass is a result of careful stylistic and qualitative research, and it enhances the wine coolers function: from a technological point of view, it protects from damaging light, and from an aesthetical point of view, it has a great visual impact, and gives maximum transparency when the light is on, and complete darkness when the light is off.

The choice of using cold LED lighting, which can be turned on from the outside without opening the door, maintains a constant temperature, and provides perfect visibility on the racks.



CVIU338RX

60 CM (APPROX. 24") BUILT-IN UNDER-COUNTER
WINE COOLER



"Classic" Design

Right-hand hinged

Fingerprint-proof stainless steel and black glass finish

Compact LCD display

Maximum storage capacity: 38 bottles

2 fixed wooden shelves

3 removable wooden shelves with telescopic guides

Active charcoal filter

External touch control display

Electronic temperature controls

2 independent temperature zones

Adjustable temperature range: 41 - 68° F (both zones)

Door open alarm

Automatic defrost

Anti-UV door glass

LED lights

Gross capacity: 4 cu ft

Voltage rating: 120V 60Hz

Connected load (nominal power): 0.40 kW - 0.5 Amps

Dimensions: W 23 ²⁷/₆₄" x H 32 ⁹/₃₂" x D 24 ¹³/₃₂"

ALSO AVAILABLE:

CVIU338LX

Left-hand hinged

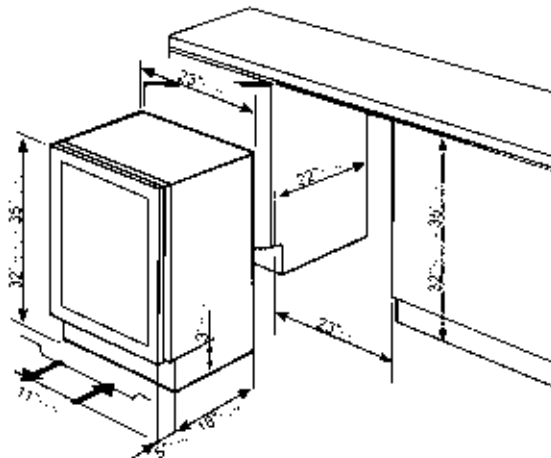

For technical drawing in metric, see page 179

CVIU318RX

60 CM (APPROX. 24") BUILT-IN WINE COOLER



"Classic" Design

Fingerprint-proof stainless steel and black glass finish
17 3/4" reduced height wine cooler

Push-pull door opening

Compact LCD display

Maximum storage capacity: 18 bottles

1 fixed wooden shelf

2 removable wooden shelves with telescopic guides

Active charcoal filter

External touch control display

Electronic temperature controls

Adjustable temperature range: 41 - 68° F

Door open alarm

Automatic defrost

Anti UV door glass

LED lights

Gross capacity: 1.84 cu ft

Voltage rating: 120V 60Hz

Connected load (nominal power): 0.40 kW - 0.5

Amps

Dimensions: W 23 7/16" x H 5 3/8" x D 21 15/16"

ALSO AVAILABLE:

CVIU318LX

Left-hand hinged



CPS315X

60 CM (APPROX. 24") SOMMELIER DRAWER



"Classic" Design

Fingerprint-proof stainless steel finish

Push opening

Slavonia durmast wooden shelf

Wine pump + 2 corks

Sparkling wine cork

Cork to pour wine

Anti-drip cork

Solid steel cork for sparkling wines

Champagne/sparkling wine pliers

Corkscrew sommelier

Red wine cork

Wine thermometer with slipcase

Wine funnel with wooden handle

Maximum weight allowed above the drawer: 187 lbs

Maximum weight allowed inside the drawer: 33 lbs

Dimensions: W 23 7/16" x H 5 3/8" x D 21 15/16"

Suitable for fitting directly beneath a 17 3/4" height wine cooler. It fits in a standard 24" gap

COORDINATES WITH:

"Classic" aesthetic



CP315X

60 CM (APPROX. 24") STORAGE DRAWER



"Classic" Design

Fingerprint-proof stainless steel finish

Push opening

Non-slip drawer liner

Maximum weight allowed above the drawer: 187 lbs

Maximum weight allowed inside the drawer: 33 lbs

Dimensions: W 23 7/16" x H 5 3/8" x D 21 15/16"

Gross capacity: 0.78 cu ft

Suitable for fitting directly beneath a 17 3/4" height wine cooler. It fits in a standard 24" gap

COORDINATES WITH:

"Classic" aesthetic

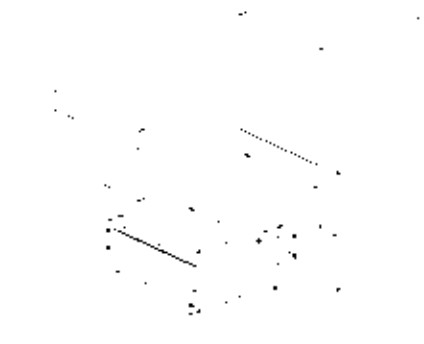

For technical drawing in metric, see page 179

COOKTOPS

High-quality materials and uniquely-designed grates and burners distinguish SMEG cooktops.



COOKTOPS

PU75ES

72 CM (APPROX. 28") PIANO DESIGN GAS COOKTOP,
POLISHED STAINLESS STEEL*



PU64ES

60 CM (APPROX. 24") PIANO DESIGN GAS
COOKTOP, POLISHED STAINLESS STEEL*



Piano Design

5 burners	
Rear-Left:	8,000 BTUs
Front-Left:	3,500 BTUs
Center double-inset super burner:	12,300 BTUs
Rear-right:	5,500 BTUs
Front-right:	3,500 BTUs

Stainless steel base
Stainless steel control knobs
Stainless steel grates
Stainless steel burner caps
"EverShine" invisible finish on burners and grates
protects against heat tarnish
Automatic electronic ignition
Safety valves
Adaptable for LP gas
Gas inlet/power supply location: back-right

Voltage rating: 120V 60Hz 0.1 Amps

OPTIONS:

GP75ES Set of st/steel grates and burner caps

*Note for cooktops with polished stainless steel pan stands: when exposed to a direct flame, all polished stainless steel will tarnish. **EverShine** invisible finish on the burners and grates of the PU75ES and the PU64ES will reduce heat tarnish.

Piano Design

4 burners	
Rear-left:	8,000 BTUs
Front-left:	5,500 BTUs
Rear-right: rapid burner	10,000 BTUs
Front-right:	3,500 BTUs

Stainless steel base
Stainless steel control knobs
Stainless steel grates
Stainless steel burner caps
Automatic electronic ignition
"EverShine" invisible finish on burners and grates
protects against heat tarnish
Safety valves
Adaptable for LP gas
Gas inlet/power supply location: back-right

Voltage rating: 120V 60Hz 0.1 Amps

OPTIONS:

GP64ES Set of st/steel grates and burner caps

EVERSHINE: PERFECT GLOSS FINISH



The polished stainless steel burner caps and pan stands of the 24" and 28" cooktops have been coated with a special transparent EverShine treatment that makes them highly resistant to heat. The treatment also attenuates tarnishing when in direct contact with the gas flame.

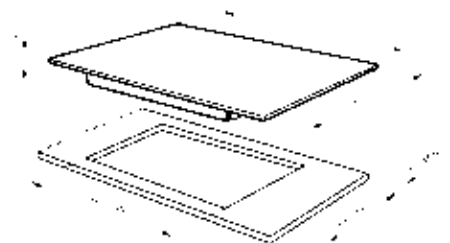
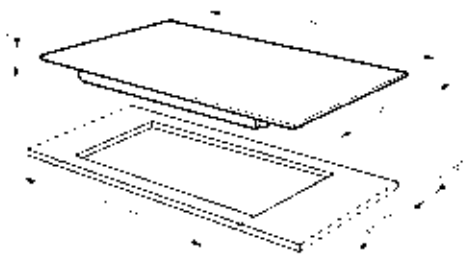

For technical drawing in metric, see page 176



PIANO DESIGN

COOKTOPS

PGFU36X

36" "CLASSIC" GAS COOKTOP, STAINLESS STEEL



"Classic" Design

Extra-wide stainless steel frame for countertop protection

5 gas burners:

Front-right:	3,600 BTUs
Back-right:	6,200 BTUs
Central double-inset super burner:	13,700 BTUs
Back-left:	6,200 BTUs
Front-left:	6,200 BTUs

AISI 304 stainless steel cooktop

Ultra-low-profile base (1/8")

Ergonomic side control knobs

Heavy-duty cast-iron grates

Full-width grates

Sealed burners

Automatic electronic ignition

Safety valves

LP gas conversion kit included

Gas inlet/power supply location: back-right

Voltage rating: 120V 60Hz 0.1 Amps

OPTIONS:

Available for PGFU36X, PGF95U3

WOKGHU Cast-iron wok ring

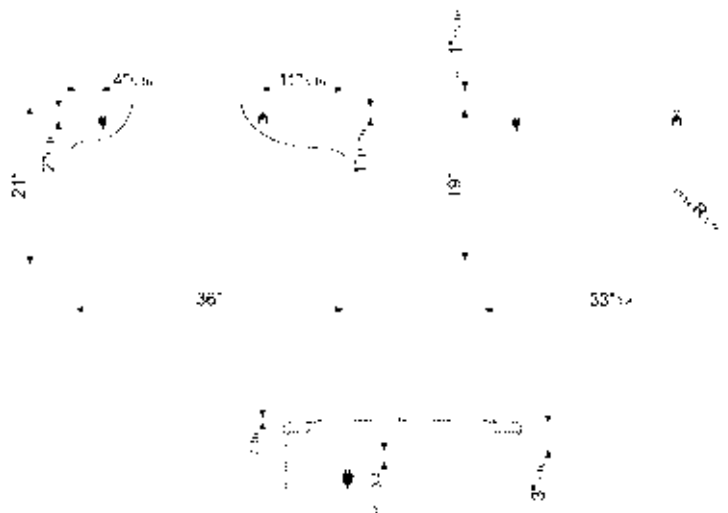

For technical drawing in metric, see page 179



CLASSIC

GAS COOKTOPS

PGFU30X

76 CM (30") "CLASSIC" GAS COOKTOP,
STAINLESS STEEL



COOKING ACCESSORIES



A range of accessories allow SMEG cooktops to become even more flexible. A special cast-iron wok support is designed for enthusiasts of East Asian cuisine, as it supports a wok perfectly, ideal for stir frying and steaming.

"Classic" Design

Extra-wide stainless steel frame for countertop protection

5 gas burners:

Front-right:	3,600 BTUs
Back-right:	6,200 BTUs
Central double-inset super burner:	13,700 BTUs
Back-left:	6,200 BTUs
Front-left:	6,200 BTUs

AISI 304 stainless steel cooktop

Ultra-low-profile base (1/8")

Ergonomic front control knobs, interchangeable to convert to "Linea" style using kit 6MP1PGF

Heavy-duty cast-iron grates

Full-width grates

Sealed burners

Automatic electronic ignition

Safety valves

LP gas conversion kit included

Gas inlet/power supply location: back-right

Voltage rating: 120V/60Hz/0.1 Amps

OPTIONS:

WOKGHU	Cast-iron wok ring
6MP1PGF	"Linea" control knobs kit

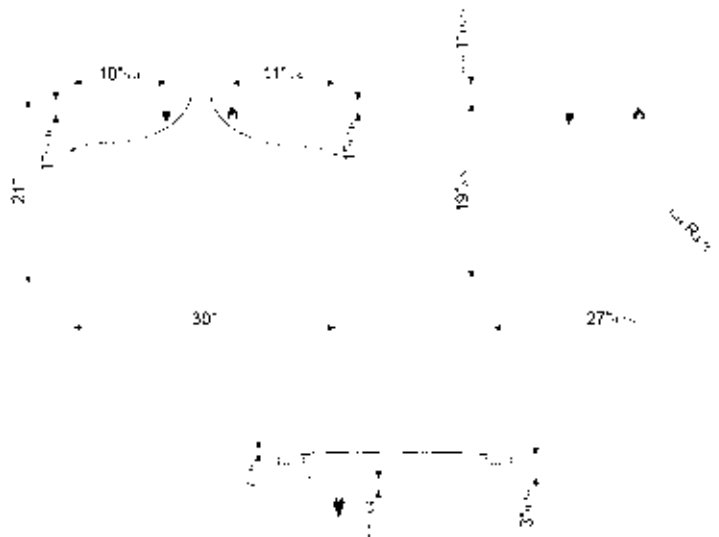

For technical drawing in metric, see page 179

SR60GHU3

60 CM (APPROX. 24") "CLASSIC" GAS COOKTOP,
STAINLESS STEEL



"Classic" Design

4 gas burners:

Left double-inset super burner: 13,300 BTUs

Back-center: 5,600 BTUs

Front-center: 3,600 BTUs

Right: 8,700 BTUs

AISI 304 stainless steel cooktop

Ergonomic front control knobs

Burner layout in diamond configuration

Heavy-duty cast-iron grates

Sealed burners

Automatic electronic ignition

Safety valves

LP gas conversion kit included

Gas inlet/power supply location: back-right

Voltage rating: 120V 60Hz 0.1 Amps

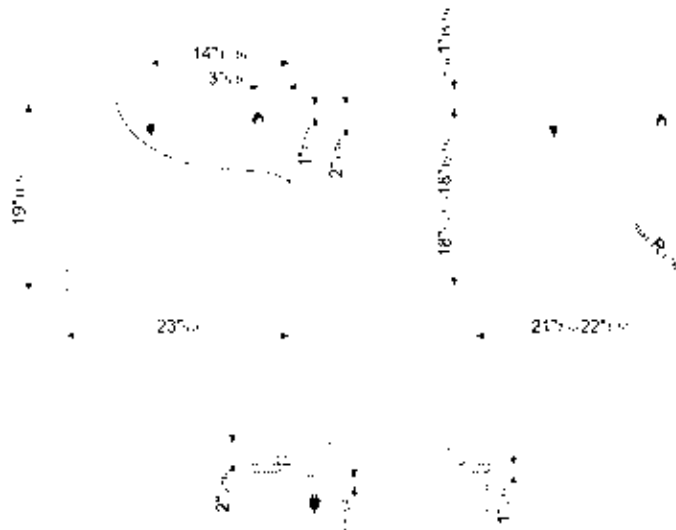

For technical drawing in metric, see page 179

SIMU524B

65 CM, (APPROX. 26") INDUCTION COOKTOP, STANDARD BUILDING TYPE FOR CANADA ONLY



4 "full-power" cook zones

Front-right:	1,200W	Ø 5 7/10" (145mm)	Booster: 2,000W
Back-right:	2,500W	Ø 9 1/2" (240mm)	Booster: 3,200W
Back-left:	1,800W	Ø 7 1/2" (180mm)	Booster: 2,500W
Front-left:	1,800W	Ø 7 1/2" (180mm)	Booster: 2,500W
Bridge zone:	15 5/32" x 9 1/16" (385x230mm) Booster: 4,000W		

Slider touch control setting

1 bridge area: extended cooking zone (front-left+back-left position)

9 power levels for each zone

Simmering function

Melting/low-temperature cooking function

Indication of minimum pan diameter

Residual heat indicator for each zone

Protection against accidental start-up

Automatic safety cut-out

Individual timer for each zone

Child safety lock

Voltage rating: 240/208V 60Hz

Connected load (nominal power): 7.4 kW - 33 Amps

Electrical - single phase 3 or 4-wire cable required, 60 Hz, fused on both sides of line with ground



For technical drawing in metric, see page 179

SIMU530B

78.2 CM (APPROX. 31") INDUCTION COOKTOP, STANDARD BUILDING TYPE



4 "full-power" cook zones

Front-central:	1,200W	Ø 6" (145mm)	Booster: 2,000W
Back-right:	2,500W	Ø 11" (270mm)	Booster: 3,700W
Back-left:	1,800W	Ø 7 1/2" (180mm)	Booster: 2,500W
Front-left:	2,500W	Ø 7 1/2" (180mm)	Booster: 2,500W
Bridge zone:	15 5/32" x 9 1/16" (385x230mm) Booster: 4,000W		

Slider touch control setting

1 bridge area: extended cooking zone (front-left+back-left position)

9 power levels for each zone

Simmering function

Melting/low-temperature cooking function

Indication of minimum pan diameter

Residual heat indicator for each zone

Protection against accidental start-up

Automatic safety cut-out

Individual timer for each zone

Child safety lock

Voltage rating: 240/208V 60Hz

Connected load (nominal power): 7.4 kW - 33 Amps

Electrical - single phase 3 or 4-wire cable required, 60Hz, fused on both sides of line with ground

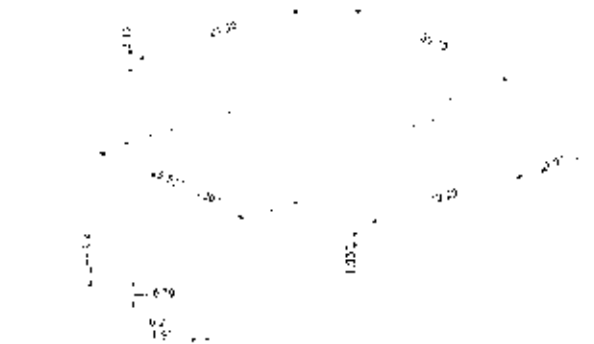

For technical drawing in metric, see page 180

SIMU536B

92 CM (APPROX. 36") INDUCTION COOKTOP, STANDARD BUILDING TYPE



5 "full-power" cook zones

Front-left - Bridge zone:	1,800W Ø 7 1/2" (180mm)	Booster: 2,500W
Back-left - Bridge zone:	1,800W Ø 7 1/2" (180mm)	Booster: 2,500W
Central:	2,800W Ø 11 9/11" (300mm)	Booster: 5,000W
Back-right - Bridge zone:	1,800W Ø 7 1/2" (180mm)	Booster: 2,500W
Front-right - Bridge zone:	1,800W Ø 7 1/2" (180mm)	Booster: 2,500W

Slider touch control setting

2 bridge areas: extended cooking zone (front-left+back-left position and front-right + back-right)

9 power levels for each zone

Simmering function

Melting/low-temperature cooking function

Indication of minimum pan diameter

Residual heat indicator for each zone

Protection against accidental start-up

Automatic safety cut-out

Individual timer for each zone

Child safety lock

Voltage rating: 240/208V 60Hz

Connected load (nominal power): 11.10 kW - 46 Amps

Electrical - single phase 3 or 4-wire cable required, 60 Hz, fused on both sides of line with ground

BRIDGE ZONE

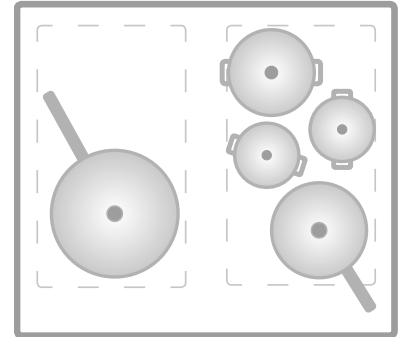

Unlike standard induction cooktops which are divided into different cooking zones where size and position is restricted, these cooktops have large bridge zones which can be divided into front and rear zones.

The bridge zone detects the size and position of the pots and pans, and heats up the exact spots where they stand, providing optimum heat distribution and efficiency. This allows several pans to be used at once, large or small, offering freedom of placement, and greater flexibility.



For technical drawing in metric, see page 180

SEU365ETB

90 CM (APPROX. 36") CERAMIC COOKTOP, BEVELED



5 high-light radiant zones:

Front-right:	Ø 5 1/2" (140mm)	Booster 1,200W
Back-right:	Ø 7 5/8" (195mm)	Booster 2,000W
Central:	Ø 5 1/2 - 8 1/4 - 10 5/8" (140-210-270mm)	Booster 750+900+1,050W
Front-left:	Ø 4 3/4 - 7" (120-180mm)	Booster 800+1,200W
Back-left:	Ø 5 1/2" (140mm)	Booster 1,200W

SoftTouch controls

5 high-light radiant elements, including 2 variable zones (central high speed zone with three-level adjustment)
9 power levels for each zone
Residual heat indicator for each zone
Automatic safety cut-out
Individual timer for each zone (1 - 99min)
Child safety lock

Voltage rating: 240/208V 60Hz

Connected load (nominal power): 240/208V - 8.6/6.5 kW - 36/32 Amps
Electrical - single phase 3 or 4-wire cable required, 60Hz, fused on both sides of line with ground

SEU304EMTB

91.4 CM (36") CERAMIC COOKTOP, BEVELED



5 high-light radiant zones:

Front-right:	Ø 5 1/2" (140mm)	Booster 1,200W
Back-right:	Ø 7 5/8" (195mm)	Booster 2,000W
Central:	Ø 5 1/2 - 8 1/4 - 10 5/8" (140-210-270mm)	Booster 750+900+1,050W
Back-left:	Ø 5 1/2" (140mm)	Booster 1,200W
Front-left:	Ø 4 3/4 - 7" (120-180mm)	Booster 800+1,200W

SoftTouch controls

5 high-light radiant elements, including 2 variable zones (central zone with three-level adjustment)
9 power levels for each zone
Residual heat indicator for each zone
Automatic safety cut-out
Individual timer for each zone (1 - 99min)
Child safety lock

Voltage rating: 240/208V 60Hz

Connected load (nominal power): 240/208V - 8.6/6.5 kW - 36/32 Amps
Electrical - single phase 3 or 4-wire cable required, 60Hz, fused on both sides of line with ground



SEU244ETB

77 CM (30") CERAMIC COOKTOP, BEVELED



4 high-light radiant zones:
Front-right: Ø 7" (180mm) Booster 1,800W
Back-right: 6 1/16 x 10 7/16" (170x265mm) Booster 1,400 + 800W
Back-left: Ø 5 1/2" (140mm) Booster 1,200W
Front-left: Ø 5 1/2 - 8 1/4" (140-210mm) Booster 1,100 + 1,300W

Soft-touch controls
4 high-light radiant elements, including 2 variable zones
9 power levels for each zone
Residual heat indicator for each zone
Automatic safety cut-out
Child safety lock

Voltage rating: 240/208V 60Hz
Connected load (nominal power): 240/208V-8.1/6.0 kW - 34/29 Amps
Electrical - single phase 3 or 4-wire cable required, 60Hz, fused on both sides of line with ground

SEU122B

30 CM (12") CERAMIC COOKTOP, BEVELED



2 high-light radiant zones:
Front: Ø 7" (180mm) Booster 1,000W
Back: Ø 5 5/11" (140mm) Booster 1,400W

Soft-touch controls
2 high-light radiant elements

9 power levels for each zone
Residual heat indicator for each zone
"Keep warm" automatic function
Automatic safety cut-out
Child safety lock
Limited power consumption mode

Voltage rating: 120V 60Hz
Quick start option
Connected load (nominal power): 2.4 kW
22 Amps
Electrical - single phase 3 wire cable required, 60Hz, fused on both sides of line with ground



REFRIGERATORS

SMEG's '50s Retro Style line is a combination of technology and aesthetics, functionality and style, which evokes the unmistakable shapes and atmospheres of the '50s stylology.

Bright colors, rounded lines and retro styling are reinterpreted with a modern view to create products which become the stars of the kitchen.



REFRIGERATORS

FAB28UITR1

SMEG REFRIGERATION

exuding technology

A variety of refrigerators, freezers, and combinations are available in different sizes and splits, freestanding or built-in.



**'50s STYLE
BOTTOM FREEZER**



**'50s STYLE
SINGLE DOOR**



**'50s STYLE
MINI REFRIGERATOR**



BOTTOM FREEZER



BUILT-IN



FRENCH DOOR

SPECIAL FEATURES

high performance



NO FROST

In "No Frost" appliances, forced air is circulated through the fridge and freezer sections separately using 2 evaporators, preventing ice from forming on the sides, and meaning that you don't have to manually defrost.



LIFE PLUS

Some models have a special compartment that is kept at a controlled temperature of 0°C/32°F, so that perishable foods can be preserved for longer.



FAST FREEZING

This option is particularly useful when you want to freeze a large quantity of fresh food. Activating the fast freeze function a couple of hours before introducing fresh food, the freezer gets ready to work on full power, bringing the temperature rapidly down.



AUTOMATIC DEFROST

This system is a time saving device that works by automatically defrosting at regular intervals, eradicating the need to defrost altogether.

SMEG FIAT 500

two Made in Italy leaders, one outstanding idea



Born from an exciting collaboration between **FIAT 500** and **SMEG**, a relationship that dates back to the 1950's, is an exclusive project which brings together two brands synonymous with the world of vintage style, design, and technological know-how. The eye-catching outcome from this merger of form and function is an extraordinary line of beverage coolers that are hand made with genuine FIAT 500 parts!



SPACE FOR STYLE

SMEG '50s retro-style

Appliances that embody the glamor and smooth forms of the 1950s. SMEG '50s retro-style refrigerators have become recognized around the world as cult objects.

This aesthetic line is composed of the FAB5 mini cooler, the one-door FAB28 fridge, and the combined, frost-free, FAB32 refrigerator with bottom freezer (shown below in pastel blue).



- - - - - Contemporary design, functionality, and low energy consumption combine to create this desirable-but-essential household object.

- - - - - 2 adjustable thermostats
Refrigerator: 8.2 cu ft capacity
3 adjustable glass shelves and 1 fruit and vegetable container
1 bottle storage shelf
Door: 3 adjustable balconies
Frost-free Freezer: 3.5 cu ft capacity
1 compartment with pull-down flap
Fast-freezing compartment

- - - - - With a frost-free freezer, and nearly 76" of height, it is useful in every kind of kitchen; available in 8 colors

INGENIOUS STORAGE SOLUTIONS

‘French door’ style

Large capacity refrigerators are much-in-demand in today’s busy world, and it is important to choose the right one to match your lifestyle. SMEG offers large models in both the ‘French door’ and ‘side-by-side’ styles to suit diverse needs, and all have timesaving frost-free freezers, with no need to defrost, along with extra-cool compartments in the refrigerator section.

A maxi refrigerator-freezer with two doors and two drawers, combining large capacity, cutting-edge design and styling with sharp, clean lines. Innovation and flexibility are the distinctive features of the new SMEG high tech line of refrigerator-freezers, where large storage capacity, high performance and low power consumption are combined with an attractive, stylish design.



ODOR FILTER

A special device neutralizes odors by filtering the cold air that circulates inside the refrigerator.

LIFE PLUS DRAWERS

Kept at the controlled temperature of 32°F, perishable foods can be preserved for longer.

MULTIZONE

This interchangeable compartment can be used as either a fridge or freezer.

SMEG500GRUS

SMEG500 COOLER, GREEN



SMEG500WHUS

SMEG500 COOLER, WHITE



SMEG500RDUS

SMEG500 COOLER, RED



Handmade with genuine original Fiat 500 parts

Net capacity: 3.5 cu ft
Temperature range: from 14° to 57° F
Open/Close with 2 sliding doors (low emission glass)
Adjustable thermostat
3 x removable bottle holders
1 x removable shelf for canned drinks

Nominal power: 70 W - 0.6 Amps
Voltage rating: 120V 60Hz
Dimensions: H 32-5/8" x W 49-1/4" D 31-1/2"
Maximum height with hood open at 80°: 59"
Refrigerant gas type: R600a
Refrigerant quantity (oz): 0.88 l



SMEG500VHUS

FAB32UCRRN

APPROX 24" '50s STYLE REFRIGERATOR WITH
AUTOMATIC FREEZER, CREAM



2 adjustable thermostats
Freezing capacity: 22 lbs/24h
Thaw time: 18h
Available in right and left hinges

REFRIGERATOR:

Fresh food capacity: 8.1 cu ft net capacity
Fresh food capacity: 8.2 cu ft gross capacity
Automatic defrost
3 adjustable glass shelves
1 fruit and vegetable container
1 covered storage box
1 chrome wine rack

FREEZER ❄️❄️❄️:

3 adjustable shelves
1 bottle rack
Frost-free
Frozen food capacity: 2.65 cu ft net capacity
Frozen food capacity: 3.43 cu ft gross capacity
2 drawers
1 fast-freezing drawer
Fast-freezing bottom
Ice cube tray
A gap of 5" must be left on the hinged side of the product to allow the door to open fully.

Voltage: 120V 60Hz
Current: 10 Amps
Noise level: 41 dB(A) RE 1 pVW

VERSIONS:

Codes with hinges on the right are shown in the images on page 119

Codes with hinges on the left are as follows:

FAB32UCRLN CREAM, left-hand hinge
FAB32UORLN ORANGE, left-hand hinge
FAB32UBLLN BLACK, left-hand hinge
FAB32URDLN RED, left-hand hinge
FAB32UPKLN PINK, left-hand hinge
FAB32UPBLN PASTEL BLUE, left-hand hinge
FAB32UWHLN WHITE, left-hand hinge
FAB32UPGLN PASTEL GREEN, left-hand hinge

DIMENSIONS:

Dimensions HxWxD:
75 ¹³/₁₆" x 23 ⁵/₈" x 26 ⁵/₈"
Door thickness: 4 ¹/₂" (door+handle: 6")
Gross weight: 191 lbs
Net weight: 222 lbs



When positioning these appliances adjacent to a kitchen unit, a gap of 5" must be left on the hinged side of the product to allow the door to open. When positioning next to a wall, it is recommended to leave a larger gap.

For technical drawing in metric, see page 181



FAB32UPGRN Pastel Green



FAB32UPBRN Pastel Blue



FAB32UPKRN Pink



FAB32UBLRN Black



FAB32URDRN Red



FAB32UWHRN White



FAB32UORRN Orange



Here you can see the combination of 2 fridges, (left and right hinge).

FAB28URDR1

APPROX 24" '50s STYLE REFRIGERATOR
WITH ICE COMPARTMENT, RED



Capacity 9.22 cu ft
Available with right and left hinge

REFRIGERATOR:

Interior light
3 adjustable glass shelves
1 bottle rack
1 fixed glass shelf
1 fruit and vegetable container
1 dairy box

DOOR:

2 adjustable covered bins
2 bottle storage bins
4 adjustable bins
2 egg bins

Freezer compartment:
1 ice cube tray

A gap of 5" must be left on the hinged side of the product to allow the door to open.

Energy consumption: 305 kWh/year
Voltage: 120V 60Hz
Current: 10 Amps
Noise level: 42 dB(A) RE 1 pW

VERSIONS:

Codes with hinges on the right are shown in the images on page 121

Codes with hinges on the left are as follows:

FAB28UYWL1 YELLOW, left-hand hinge
FAB28ULIL1 LIME GREEN, left-hand hinge
FAB28UORL1 ORANGE, left-hand hinge
FAB28UPBL1 PASTEL BLUE, left-hand hinge
FAB28UPKL1 PINK, left-hand hinge
FAB28UPGL1 PASTEL GREEN, left-hand hinge
FAB28URDL1 RED, left-hand hinge
FAB28UWHL1 WHITE, left-hand hinge
FAB28UBEL1 BLUE, left-hand hinge
FAB28USVL1 SILVER, left-hand hinge
FAB28UBLL1 BLACK, left-hand hinge
FAB28UCRL1 CREAM, left-hand hinge

DIMENSIONS:

Dimensions HxWxD:
57 1/2" x 23 5/8" x 27 1/2"
Door thickness: 4 1/2" (door+handle: 6")
Gross weight: 181.4 lbs
Net weight: 156.5 lbs



When positioning these appliances adjacent to a kitchen unit, a gap of 5" must be left on the hinged side of the product to allow the door to open. When positioning next to a wall, it is recommended to leave a larger gap.

For technical drawing in metric, see page 181



FAB28UPGR1 Pastel Green



FAB28UPBR1 Pastel Blue



FAB28UPKR1 Pink



FAB28UBLR1 Black



FAB28UCRR1 Cream



FAB28UWHR1 White



FAB28UYWR1 Yellow



FAB28ULIR1 Lime Green



FAB28UORR1 Orange



FAB28USVR1 Silver



FAB28URDR1 Red



FAB28UBER1 Blue

FAB28UITR1

APPROX 24" '50s STYLE REFRIGERATOR
WITH ICE COMPARTMENT,
ITALIAN FLAG



FAB28UUJR1

APPROX 24" '50s STYLE REFRIGERATOR
WITH ICE COMPARTMENT,
UNION JACK FLAG



FAB28UUSR1

APPROX 24" '50s STYLE REFRIGERATOR
WITH ICE COMPARTMENT,
UNITED STATES FLAG



Capacity 9.22 cu ft
Available with right and left hinge

REFRIGERATOR:

Interior light
3 adjustable glass shelves
1 bottle rack
1 fixed glass shelf
1 fruit and vegetable container
1 dairy box

DOOR:

2 adjustable covered bins
2 bottle storage bins
4 adjustable bins
2 egg bins

Freezer compartment:
1 ice cube tray

A gap of 5" must be left on the hinged side of the product to allow the door to open.

Energy consumption: 305 kWh/year
Voltage: 120V 60Hz
Current: 10 Amps
Noise level: 42 dB(A) RE 1pW

VERSIONS:

Codes with hinges on the left are as follows:

FAB28UITL1 ITALIAN FLAG, Left hinge
FAB28UUJL1 UNION JACK, left-hand hinge
FAB28UUSL1 USA FLAG, left-hand hinge

DIMENSIONS:

Dimensions HxVxD:
57 1/2" x 23 5/8" x 27 1/2"
Door thickness: 4 1/2" (door+handle: 6")
Gross weight: 181.4 lbs
Net weight: 156.5 lbs



When positioning these appliances adjacent to a kitchen unit, a gap of 5" must be left on the hinged side of the product to allow the door to open. When positioning next to a wall, it is recommended to leave a larger gap.

For technical drawing in metric, see page 181



REFRIGERATORS '50s STYLE

APPROX. 16" '50s STYLE MINI COOLER, BLACK



FAB5URO
Orange



FAB5URP
Cream



FAB5URR
Red



FAB5URUJ
Union Jack

ABSORPTION COOLING

MINI COOLERS use an ABSORPTION COOLING system in place of the usual compressors which are found in other SMEG refrigeration units. The great advantage of this system is that it has an EXTREMELY LOW OPERATIONAL NOISE LEVEL. In fact, the FAB5 running at 29 dB (A) RE 1 pW is hardly heard at all. MINI FRIDGES have been used traditionally in hotel bedrooms, but are now available for home use, too.

The FAB5 may be the tiniest model in the SMEG '50s Retro range, but there is still plenty of space for a selection of drinks and snacks.



Capacity 1.5 cu ft
Available with right and left hinge

Absorption cooling = ultra-low noise level
Automatic defrost
LED internal light
2 adjustable shelves
Door storage: 1 balcony shelf, 1 bottle shelf

ELECTRICAL CONNECTION:
Voltage: 120V 60Hz
Current: 1.0 Amps

VERSIONS:
Codes with hinges on the right are shown in the images on page 88.

Codes with hinges on the left are as follows:
FAB5ULNE BLACK, left-hand hinge
FAB5ULO ORANGE, left-hand hinge
FAB5ULP CREAM, left-hand hinge
FAB5ULR RED, left-hand hinge
FAB5ULUJ UNION JACK, left-hand hinge

DIMENSIONS:
Dimensions: HxWxD:
28 1/8" x 15 15/16" x 22 1/16"
Gross weight: 65 lbs
Net weight: 51.2 lbs



For technical drawing in metric, see page 181



'50s STYLE

REFRIGERATORS

FQ50UFXE

90 CM (APPROX. 36"), FRENCH DOOR
REFRIGERATOR/FREEZER, 2 DOORS & 2 DRAWERS,
STAINLESS STEEL



Free Standing
Standard hinge
Counter Depth
Fingerprint-proof stainless steel finish

Display: LCD touch
Display functions: Holiday, Fast Freezing,
Fast Cooling, Multizone, Energy Efficiency Mode,
Child Safety Lock, Door Open Alarm
Adaptable compartment
(freezer or refrigerator space)

REFRIGERATOR COMPARTMENT FEATURES:

Life Plus Zone 32° F
2 glass adjustable shelves
2 fruit and vegetables drawers
Glass crisper cover
LED refrigerator internal light

REFRIGERATOR INNER DOOR:

2 door balconies with transparent cover
4 adjustable balconies
2 bottle balconies
1 egg tray

FREEZER COMPARTMENT FEATURES:

2 drawers
No frost

OTHER FREEZER FEATURES:

Automatic ice maker
Ice tray shelf

PERFORMANCE/ENERGY LABEL:

Annual energy consumption: 623 kWh
Fresh food compartment net volume: 14.70 cu ft
Freezer compartment net volume: 5.97 cu ft
Frozen food compartment star rating: 4
Frostfree system
Freezing capacity: 13 kg/h
Noise level: 45 dB(A)

ELECTRICAL CONNECTION:

Electrical connection rating: 160 W
Current: 2.7 Amp
Voltage rating: 120V 60Hz

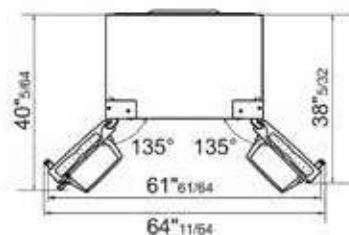
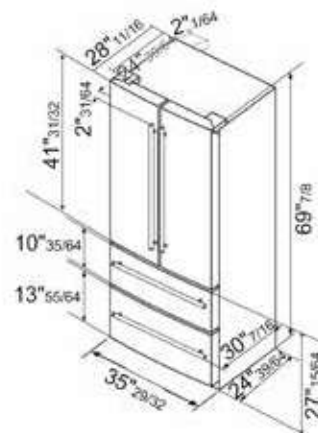

For technical drawing in metric, see page 181



REFRIGERATORS

FTU171X7

90 CM (APPROX. 36"), FRENCH DOOR
REFRIGERATOR/FREEZER, 2 DOORS & 1 DRAWER,
STAINLESS STEEL



Free Standing
Standard hinge
Fingerprint-proof stainless steel finish

Convenient ice and water dispenser
Display: LCD
Display functions: Fast Freezing, Fast Cooling,
Temperature Alarm

REFRIGERATOR COMPARTMENT FEATURES:

Glass adjustable shelves
Crisper compartment
LED refrigerator internal lighting

REFRIGERATOR INNER DOOR:

2 balconies with transparent covers
3 adjustable balconies
2 bottle balconies
1 egg tray
Natural Plus Light

FREEZER COMPARTMENT FEATURES:

1 drawer
No frost

OTHER FREEZER FEATURES:

Automatic ice maker
Ice trayshelf
Fastfreezing compartment

PERFORMANCE/ENERGY LABEL:

Annual energy consumption: 681 kWh
Fresh food compartment net volume: 18.4 cu ft
Freezer compartment net volume: 7.7 cu ft
Frostfree system
Noise level: 43 dB(A)

ELECTRICAL CONNECTION:

Electrical connection rating: 160 W
Current: 2.7 Amp
Voltage rating: 120V 60Hz

DIMENSIONS:

With door opened to 90°:
Dimensions HxWxD:
69 13/16" x 36" x 32 1/2"

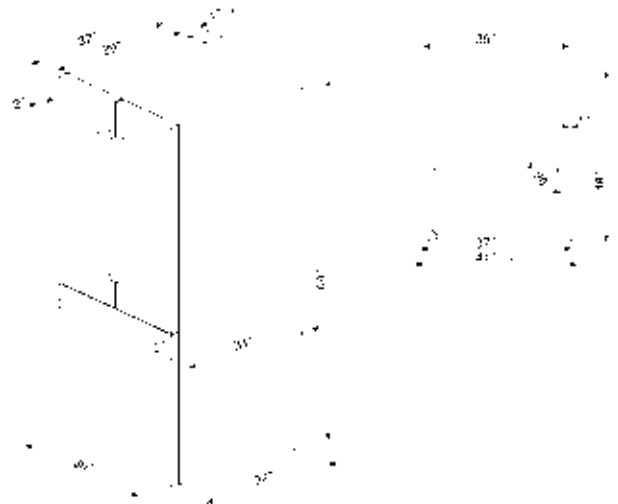

For technical drawing in metric, see page 181

FC200UXE

60 CM (APPROX. 24"), COMBI REFRIGERATOR/
FREEZER, STAINLESS STEEL



Standard hinge, right
Reversible to left hinge
Counter Depth
Fingerprint-proof stainless steel finish

Display: LCD
Display functions: Fast Freezing, Fast Cooling,
Temperature Alarm, ECO mode

REFRIGERATOR COMPARTMENT FEATURES:

Life Plus Zone 32° F
Multiflow
Ionizer
3 glass adjustable shelves
1 fruit and vegetable drawer
1 bottle shelf
Crisper compartment
LED refrigerator internal lighting

REFRIGERATOR INNER DOOR:

3 adjustable balconies
1 bottle balcony
1 egg tray
1 butter tray

FREEZER COMPARTMENT FEATURES:

3 drawers

OTHER FREEZER FEATURES:

Fast-freezing compartment

PERFORMANCE/ENERGY LABEL:

Annual energy consumption: 390 kWh
Fresh food compartment net volume: 8.4 cu ft
Freezer compartment net volume: 3 cu ft
Frozen food compartment star rating: 4
Frost-free system
Freezing capacity: 12 kg/h
Noise level: 42 dB(A)

ELECTRICAL CONNECTION:

Electrical connection rating: 110 W
0.9 Amp
Voltage rating: 120V 60Hz

DIMENSIONS:

With door opened to 90°: 47 1/16"
Dimensions HxWxD
78 3/8" x 23 7/16" x 23 1/4"



REFRIGERATORS

For technical drawing in metric, see page 181

CB300U

24" FULLY-INTEGRATED REFRIGERATOR/FREEZER

EXCELLENT INSULATION

Special devices, specifically designed to muffle the sound generated during operation, keep the noise to a minimum for maximum comfort in the environment.



FROST-FREE

The no-frost system prevents ice from forming so that no defrosting is required.



ELECTRICAL CONNECTION:

Electrical connection rating: 170 W - 1.4 Amp
Voltage rating: 120V 60Hz

DIMENSIONS:

Dimensions: HxWxD:
71 9/16" x 21 7/16" x 23 1/4"

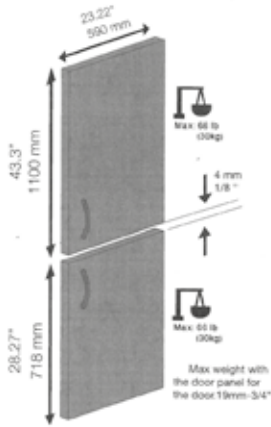

Hinge position: right
Reversible to left hinge
Counter depth
Require custom door panel

REFRIGERATOR COMPARTMENT FEATURES:

Storage volume of fresh food compartment:
6.1 cu ft
White LED
Bottle holder
3 safety glass shelves
3 door balconies
1 egg tray
Crisper compartment

FREEZER COMPARTMENT FEATURES:

Net freezer volume: 2.3 cu ft
3 drawers
Glass shelves
Fast freezing compartment
Ice cube tray
Electronic display with touch
Anti-bacterial seal
Hygiene + anti-bacterial carbon filter

Display key lock
Eco fuzzy function and eco mode
Holiday mode

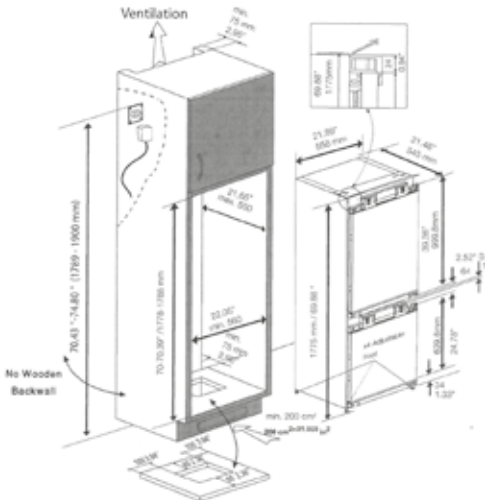

For technical drawing in metric, see page 181



REFRIGERATORS

DISHWASHERS

Essential and distinguished, SMEG dishwashers utilize numerous features and program options, ensuring efficiency and convenience.

Thoroughly researched and developed, SMEG dishwashers exemplify high-quality construction with energy-saving features, resulting in excellent performance.



DISHWASHERS

MAXIMUM WASH PERFORMANCE

SMEG wash systems

Excellent wash results are ensured by the SMEG-patented wash systems which have revolutionized dishwashing, delivering optimum wash results while maintaining low consumption of water and energy. Spray arm jets on each dishwasher are perfectly shaped to direct water with precision so that the noise level is kept as low as possible.

PLANETARIUM WASH SYSTEM (24" MODELS)

The NEW Planetarium wash system, patented by SMEG, ensures maximum wash coverage within the dishwasher by using an innovative double motion of the spray arm.

For every revolution of the main arm, it turns clockwise with a planetary movement around one axis, while at the same time the stem of the arm moves in the opposite direction, operating on a second axis. This spiralizing directional wash sprays water evenly in a 360° sweep. The rotation speed is approximately 65rpm, giving the best wash results available.

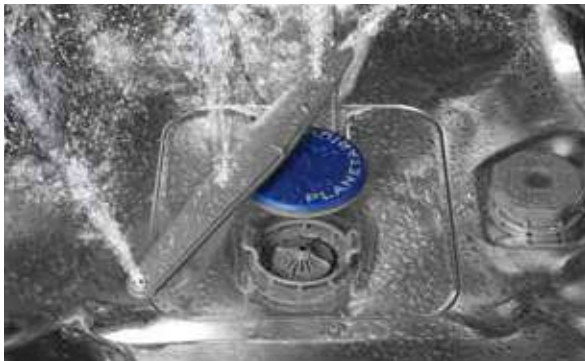

ORBITAL WASH SYSTEM (24" MODELS)

The Orbital Wash System in 24" dishwashers consists of a double spray arm-with contra-action rotation, which distributes water evenly throughout the cavity.



SHUTTLE WASH SYSTEM (18" MODELS)

The Shuttle Wash System on 18" dishwashers consists of a lower spray arm which is shuttled from front to back on a secondary supporting arm, ensuring optimum water distribution throughout the rectangular-shaped-tub.



WATER LEAK PROTECTION

All models have an electronic device fitted to the water intake hose, which monitors water levels in the machine. It detects leaks in the hose and switches off the water supply immediately if necessary.



FLEXIDUO CUTLERY BASKET

The third cutlery basket; the SMEG Flexi Duo, consists of 2 separate and movable sections which can be adjusted individually or even removed entirely depending on your loading needs. An intelligent solution that makes room for tall glasses below or deep utensils above.



PLACE SETTINGS

The range also includes an 18" dishwasher with 10 place settings, a great solution for singles, small kitchens, bar areas, or for use as a secondary dishwasher. This machine allows smaller daily wash cycles to be run efficiently in comparison with a 24" model, where the same load size would leave wasted space.

LOAD FLEXIBILITY AND INTELLIGENT LOAD

designed to optimize efficiency

SMEG's unique dishwasher baskets are made from stainless steel and covered in plastic to lower the noise level during the wash. They have been carefully designed to optimize the use of the available space. The "open space" design increases wash and load efficiency, while various adjustable flip down spike rails, racks, and cutlery baskets can be employed to customize the layout of the basket. Intelligent load, available on some models, allows you to wash a reduced load, saving energy, water, and time, and there are no restrictions on where the items are placed.



full-size tub

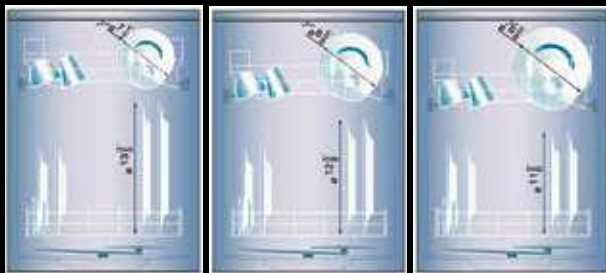

24" SMEG dishwashers for the US market all have a full-size tub – with plenty of space for large dishes or saucepans. The upper basket has a 3-position adjustment to accommodate taller dishes (from 11" up to 13 ¾" in diameter). 18" dishwasher baskets have the possibility of being adjusted to 2 separate heights.



AQUATEST

The 18" SMEG dishwasher has an Aquatest feature. A specially-developed infrared sensor measures the clarity of the water in the tub at regular intervals, and decides whether to heat the water for the pre-wash cycle, or to move on to heat the water for the wash cycle. The aquatest feature is incorporated in the AUTO cycle(s) - it keeps consumption of water and energy to a minimum, depending on the degree of food and oil on the dishes.



SANITATION AND FAST DRY

A special final 10 minute rinse at 158°F is added to the end of at least one wash program to ensure the highest-possible standards of cleanliness and hygiene. SMEG dishwashers are ETL sanitation-certified. A fast dry option for a better dry is available on some models.



ENERGY STAR AND ISO14001 CERTIFIED

The SMEG production process is carefully managed in order to keep the impact upon the environment as low as possible. The process is checked and certified by Independent International bodies IQNET and CISQ (SMEG complies with the standard ISO14001).

All SMEG dishwashers are ENERGY STAR qualified. Energy efficiency is important to SMEG, and our technicians are constantly working to keep the energy and water consumption of each dishwasher as low as possible.

STFABUPB-1

APPROX 24" PRE-FINISHED UNDER-COUNTER
DISHWASHER WITH '50S STYLE RETRO HANDLE,
PASTEL BLUE



STFABUWH
White



STFABURD-1
Red



STFABUBL-1
Black



STFABUCR-1
Cream



Full-size tub
Hidden stainless steel electronic control panel
Self-balancing door
9 wash cycles including crystal washing,
Economy Cycle and speed (27min)
Sanitation
Condenser drying
Stainless steel tub and filter
Concealed heating element
Halfload
Delay timer (up to 9 hours)
5 temperatures: 100°F, 113°F, 122°F, 149°F,
158°F

Orbital Wash System

Complete Water Leak Protection System

13 place settings

Third upper basket for cutlery, featuring FlexiDuo

Enameled steel baskets
Adjustable upper basket to accommodate plates
up to 13 3/4" in diameter
2 cutlery baskets
4 flip-down spike rails on lower basket
2 glass support racks in upper basket
Lower basket with double foldable rack

Noise level: 43 dB(A)

Energy Star-rated

Height leveling legs

Voltage rating: 120V 60Hz

Nominal power: 1,800 W 13 Amps

Water usage: normal/short cycle:

3.54/1.72 gal

OPTIONS:

KITPL60FABX Stainless steel toe kick adjustable for
underbenck dishwashers with fixed
fulcrum hinge

KIT6FIL 4 cm stainless steel filler for fully-
integrated FAB dishwashers

THIRD UPPER BASKET FOR CUTLERY FLEXIDUO

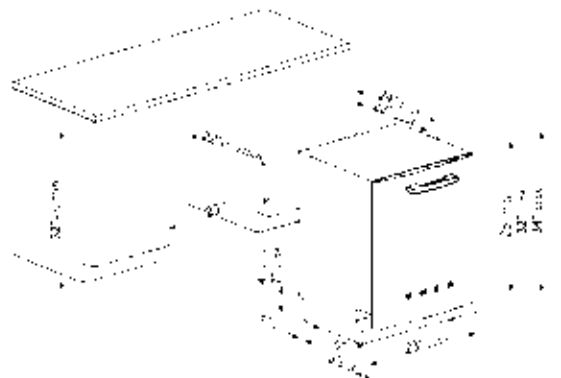

For technical drawing in metric, see page 182



'50s STYLE

DISHWASHERS

STU8647X

60 CM (APPROX. 24") PRE-FINISHED DISHWASHER WITH FINGERPRINT-PROOF STAINLESS STEEL, **MAXI-HEIGHT DOOR**, AND PROFESSIONAL HANDLE



STU8647

60 CM (APPROX. 24") FULLY INTEGRATED, PANEL-READY DISHWASHER



FLEXIDUO CUTLERY BASKET

The third cutlery basket FlexiDuo consists of 2 separate and movable sections which can be adjusted individually or even removed entirely depending on your loading needs. An intelligent solution that makes room for tall glasses below, or deep utensils above.



Full-size tub
Hidden stainless steel electronic control panel
Self-balancing door
Adjustable feet: 70 mm, from 860 to 930 mm

5 wash cycles including Crystal Washing, **Economy Cycle And Speed (27min)** and 5 quick programs

Soak, Crystal, Daily, Quick (27 min), ECO Quick, Delicate and Quick, Normal Quick.

Condenser drying
Stainless steel tub and filter
Concealed heating element

1/2 load FlexiZone option (varied distribution)

Quick Time option

Flexi tabs option

Delay timer option: up to 24 hours, with automatic soak

5 temperatures: 100°F, 113°F, 122°F, 149°F, 158°F

Salt and rinse aid refill indicators

Orbital Wash System

Complete Water Leak Protection System

Total "AquaStop" Water Protection System

Water softener with electronic setting

Turbidity sensor Aquatest

13 place settings

Gray baskets

Wirehandle

Third upper basket for cutlery: FlexiDuo

Upper Basket with central fixed racks

Height adjustment of the upper basket: On three horizontal levels

Largest loadable dish, upper basket: 23.5 cm

Lower Basket with single foldable rack

Largest loadable dish, lower basket: 35 cm

Display: Delayed start, program time indicator, Time - to - end indicator

Noise level: 47dB (A)

Energy Star-rated

Height leveling legs

Voltage rating: 120V 60 Hz
Nominal power: 13 Amps 1,800 W
Voltage 110-120V: Frequency 60Hz.
Water usage: normal/short cycle:
3.17/ 2.38 gal

OPTIONS FOR STU8647:

KIT86X	Fingerprint-proof stainless steel door panel without handle
KITCH	"Classic" handle
KITOH	Opera handle
KIT86PORTX	Stainless steel door panel with Portofino handle
KIT86VX	Stainless steel door panel with Victoria handle
KIT860XU	Piano Design handle

STU8642

FULLY INTEGRATED 24" DISHWASHER,
86 CM HEIGHT



OPTIONS FOR STU8642:

KIT86CXF Stainless steel door panel with "Classic" handle

Full-size tub
 Hidden electronic control panel
 Accepts custom panel
 Self-balancing door
 Hinges: Self balancing, Sliding, **FLEXIFit sliding**
 Adjustable feet: 7cm, from 860 to 930 mm
 5 wash cycles including Crystal Washing + 5 quick programs
 Soak, Crystal, Daily, Quick (27 min), ECO Quick, Delicate and Quick, Normal Quick, Auto Delicate, Auto Super Wash, Strong and Fast
Ener Save: energy saving option with automatic opening at the end of the cycle
 Stainless steel tub and filter
 Concealed heating element
1/2 load FlexiZone option (varied distribution)
Quick Time option
Delay timer option: up to 24h, with automatic soak
 5 temperatures: 100°F, 113°F, 122°F, 149°F, 158°F
 Salt and rinse aid refill indicators
Planetarium Wash System
 Complete Water Leak Protection System
Total "Aquastop" Water Protection System
 Water softener with electronic setting
Turbidity sensor Aquatest
 13 place settings
 Gray baskets
 Wire handle grip (lower basket)
Third upper basket for cutlery: FlexiDuo
 Upper Basket with central fixed racks
 Height adjustment of the upper basket: on three levels
 largest loadable dish in upper basket: 23.5 cm
 Lower basket with single foldable rack
 Lower basket with anti-drip inserts
 Largest loadable dish in lower basket: 35 cm
 Display: delayed start, program time indicator, Time-to-end indication
Internal white LED lights
End-of-cycle indicator: ActiveLight with LED light

Noise level: 42dB (A)
 Energy Star-rated
 Height leveling legs

Voltage rating: 120V 60Hz
 Nominal power: 13 Amps - 1,800 W
 Voltage 110-120V: Frequency 60Hz.
 Water usage: normal/short cycle:
 3.17/ 2.38 gal

SLIDING DOOR SYSTEM

Models equipped with the new FlexiFit hinge are able to be installed in kitchens with a toe kick from 2" up to 8"1/2. This revolutionary hinge allows the panel to slide from the bottom to the top, avoiding any possible interference of the panel with the toe kick. Another practical SMEG innovation!

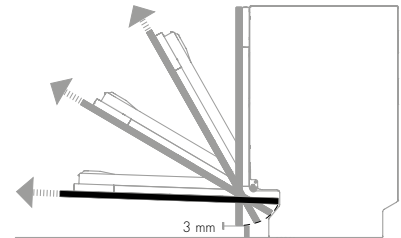

ACTIVE LIGHT

Useful function which projects a red spot onto the floor beneath the dishwasher when the appliance is in-use. This makes it immediately obvious that the appliance is running, so that the door is not accidentally opened before the wash phase has finished.



DISHWASHERS

STU8649X

60 CM (APPROX. 24") PRE-FINISHED DISHWASHER
WITH FINGERPRINT-PROOF STAINLESS STEEL,
MAXI-HEIGHT DOOR AND PROFESSIONAL HANDLE



STU8649

60 CM (APPROX. 24") FULLY
INTEGRATED, PANEL-READY
DISHWASHER



Full-size tub
Hidden electronic control panel
Self-balancing door
Hinges: self balancing with fixed hinges
Adjustable feet: 7cm, from 860 to 930 mm

5 wash cycles including crystal washing + 5 quick programs
Soak, Crystal, 1/2 Daily, ECO Quick, Delicate and Quick, Normal Quick, Extreme Wash
Stainless steel tub and filter
Concealed heating element
Quick Time option
Flexi tabs option
Delay timer option: up to 9 hours, with automatic soak
5 temperatures: 100°F, 113°F, 122°F, 149°F, 158°F
Salt and rinse aid refill indicators
Orbital Wash System
Water Leak Protection System
Single "AquaStop" Water Protection System
13 place settings
Display with delayed start option
Gray baskets
Lower basket with wire handle grip
Upper basket with central fixed racks
Height adjustment of the upper basket: on two levels, by extraction
Largest loadable dish, upper basket: 23.5 cm
Lower basket with single foldable rack
Largest loadable dish, lower basket: 35 cm

Noise level: 49dB (A)
Energy Star-rated
Height leveling legs

Voltage rating: 120V 60Hz
Nominal power: 1,800 W 13 Amps
Water usage: normal/short cycle:
3.17/ 2.38 gal

OPTIONS FOR STU8649, FULLY-INTEGRATED MODEL:

KIT86X Fingerprint-proof stainless steel door panel without handle
KITCH "Classic" handle
KITOH Opera handle
KIT86PORTX Stainless steel door panel with Portofino handle
KIT86VX Stainless steel door panel with Victoria handle
KIT86OXU Piano Design handle

STU8249

60 CM (APPROX. 24") FULLY INTEGRATED, PANEL-READY DISHWASHER, **ADA HEIGHT COMPLIANT**



Euro tub size
ADA compliant
Hidden electronic control panel
Accepts custom panel
Self-balancing door

5 wash cycles including crystal washing, Extreme wash, Soak, Daily 1/2 load, Crystal, Normal USA
Stainless steel tub and filter
Concealed heating element
Half-load
Delay timer option: 3-6-9 hours with automatic soak
5 temperatures: 100°F, 113°F, 122°F, 149°F, 158°F
Salt and rinse aid refill indicators
Orbital Wash System
Water Leak Protection System
Single "AquaStop" Water Protection System

13 place settings

Gray baskets
Upper Basket: With central fixed racks
Height adjustment of the upper basket: On two levels, by extraction
Largest loadable dish upper basket: 23,5 cm
Lower Basket: With single foldable rack
Lower basket with anti-drop inserts
Largest loadable dish lower basket: 35 cm
Cutlery basket: 13 place settings sliding
Noise level: 49 dB (A)
Energy Star-rated
Height leveling legs

Voltage rating: 120V - 60 Hz
Nominal power: 13Amps - 1800 W
Voltage 110-120V: Frequency 60 Hz
Water usage: normal/short cycle: 3.17/ 2.38 gal

OPTIONS:

KIT6CX Fingerprint-proof stainless steel door panel with Classic handle
KIT6PX Fingerprint-proof stainless steel door panel with Piano handle
KITPL60X Stainless steel toe kick adjustable for underbenck dishwashers
KITPL60N Black toe kick adjustable for underbenck dishwashers
KITPL60B White steel toe kick adjustable for underbenck dishwashers

STU1846

45 CM (APPROX. 18") FULLY-INTEGRATED, PANEL-READY DISHWASHER, **ADA HEIGHT COMPLIANT**



Euro tub size
ADA compliant
Hidden electronic control panel,
Accepts custom panel
Self-balancing door

5 wash + 5 program cycles including Crystal Washing, Soak, Crystal, Normal, Speed (27 min), ECO Quick, Delicate Quick, Normal Quick, Strong and Fast, Extreme Wash, Soak and Daily 1/2 Load
Stainless steel tub and filter
Concealed heating element
Delay-timer: 3-6-9 hours, with automatic soak
5 temperatures: 100°F, 113°F, 122°F, 149°F, 158°F
Salt and rinse aid refill indicators
Shuttle Wash System
Quick time option
Complete Water Leak Protection System
Total "AquaStop" Water Protection System
Turbidity sensor Aquatest

10 place settings

Gray baskets
Wire Handle grip (lower basket)
Upper basket with central fixed racks
Height adjustment of the upper basket: on three levels
Largest loadable dish, upper basket: 23.5 cm
Lower basket with single foldable rack
Lower basket with anti-drip inserts
Largest loadable dish, lower basket: 30 cm

Noise level: 46 dB (A)
Energy Star-rated
Height leveling legs

Voltage rating: 120V 60Hz
Nominal power: 1,800 W 13 Amps
Water usage: normal/short cycle: 3.17/ 2.38 gal

OPTIONS:

KIT45XU Fingerprint-proof stainless steel door panel with "Classic" style handle

STU8249

STU1846

For technical drawing in metric, see page 182



Sicily is my love

Dolce&Gabbana and SMEG join creative forces to create Sicily is my Love, a new unique project Made in Italy. The new small appliances collection is produced by SMEG with an unmistakable Dolce&Gabbana touch.

Toasters, citrus juicers, espresso coffee machines, kettles, blenders, stand mixers and slow juicers all decorated with gold lemons, citrus fruits, prickly pears, and bright red cherries in timeless Mediterranean style.

DOLCE & GABBANA
smeg

Sicily is my love



FINE ART DECORATION
DOLCE&GABBANA Artwork
SMEG embodied technology
MADE IN ITALY

TSF01DGUS

SICILY IS MY LOVE, 2X2 SLICE TOASTER



Powder-coated steel body
Polished chrome base
Stainless steel ball lever knob
Backlit chrome knob

2 extra-wide slots (36mm/1.4" each)
Self-centring racks
Automatic slice pop-up
Removable stainless steel crumb tray
Built-in cord wrap
Anti-slip feet

6 browning levels
3 pre-set programs: Reheat, Defrost, Bagel

Dimensions HxLxW:
10" x 15" x 9"
Net weight: 5.4 lbs
Cord length: 39"

Rating: 120V
Frequency: 60Hz
Power: 950 W

TSF02DGUS

SICILY IS MY LOVE, 4X2 SLICE TOASTER



Powder-coated steel body
Polished chrome base
Stainless steel ball lever knob
Backlit chrome knob

2 extra-wide slots (36mm/1.4" each)
Self-centring racks
Automatic slice pop-up
Removable stainless steel crumb tray
Built-in cord wrap
Anti-slip feet

6 browning levels
3 pre-set programs: Reheat, Defrost, Bagel

Dimensions HxLxW:
11" x 18" x 10"
Net weight: 7.5 lbs
Cord length: 39"

Rating: 120V
Frequency: 60Hz
Power: 1,400 W

KLF03DGUS

SICILY IS MY LOVE, KETTLE



Stainless-steel powder coated body
Polished chrome base
Stainless steel ball lever knob
Stainless steel spout
Chrome handle

1.7 lt/ 7-Cup jug capacity
Soft-opening lid
Double water indication cup
Removable stainless steel limescale filter
Auto shut-off at 100°C/ 212°F
Auto shut-off when water not detected
360° swivel base
Concealed heating element
Built-in cord wrap
Anti-slip feet

Dimensions HxLxW:
10" x 11" x 9"
Net weight: 3.5 lbs
Cord length: 39"

Rating: 120V
Frequency: 60Hz
Power: 1,500 W

BLF01DGUS

SICILY IS MY LOVE, BLENDER



Die-cast aluminum powder-coated body
Backlit chrome knob

1.5 lt/ 48 oz/ 6-Cup Tritan™ BPA-free jug
Transparent lid with measuring cup
Stainless steel dual blades, detachable
Safety lock when removing blender jug
Overload motor protection
Motor with Smooth Start function
Built-in cord wrap
Anti-slip feet

4 speeds
3 preset programs: smoothie, ice crush, pulse

Dimensions HxLxW:
10" x 14" x 11"
Net weight: 8.8 lbs
Cord length: 39"

Rating: 120V
Frequency: 60Hz
Power: 600 W

CJF01DGUS

SICILY IS MY LOVE, CITRUS JUICER



Die-cast aluminum powder coated body

Universal stainless steel strainer
Stainless steel reamer
Tritan™ Lid
Anti-drip stainless steel spout
Tritan™ juicing bowl
Chrome-plated ring and inner bowl
Built-in cord wrap
Anti-slip feet
Automatic On/Off

Dimensions HxLxW:
11" x 7" x 7"
Net weight: 5.64 lbs
Cord length: 39"

Rating: 120V
Frequency: 60Hz
Power: 80 W

SJF01DGUS

SICILY IS MY LOVE, SLOW JUICER



Plastic body and hopper
Stainless steel cycle activation/Reverse function ball lever

Slow Squeezing Technology (SST™)
Rotations: 43 rpm
Juice density regulation lever
500 ml/ 17 Oz juice collector bowl in TRITAN™
Auger and strainer rotating brush in ULTEM™*
Strainer rotating brush with 4 brushes, 2 of those in silicone material, for a pure juice
"Reverse" function
Anti-slip feet
*Ultem is a SABIC trademark

Dimensions HxLxW:
17" x 13" x 15"
Net weight: 16 lbs
Cord length: 39"

Rating: 120V
Frequency: 60Hz
Power: 150 W

INCLUDED ACCESSORIES:

2 strainers (fine and coarse)
1 pusher
1 juice container(1 L/32 Oz)
1 pulp container (1.6 L/54 Oz)
2 cleaning brushes
Recipe book containing 12 recipes and recommendations

ECF01DGUS

SICILY IS MY LOVE, ESPRESSO COFFEE MACHINE



Stainless steel wrap and plastic painted housing
Stainless steel cup holder and passive cup warmer
Chrome zamak steam lever
Chrome-plated base

Thermoblock heating system
1.5 bar pressure
St/steel filter holder for powdered coffee (1/2 cup) or paper pods
Anti-drip system
User-friendly control panel
Removable drip-tray for mug accommodation
1L removable water tank with optional water filter
Anti-slip feet

Functions: 1-cup button; 2-cup button; Steam option
Adjustable Cappuccino system
Flow Stop function to customize your coffee length
Adjustable coffee temperature
Adjustable water hardness
Hot water dispenser
Descaling light indicator
On/Off button with automatic stand-by

Dimensions HxLxW:
12" x 13" x 6"
Net weight: 11 lbs
Cord length: 39"

Rating: 120V
Frequency: 60 Hz
Power: 1,300 W

INCLUDED ACCESSORIES:

3 filters (1 cup, 2 cups, paper pods)
1 measure/presser

SMF01DGUS

SICILY IS MY LOVE, STAND MIXER



Die-cast aluminum body
Zinc-alloy base with stainless steel bowl lock
Stainless steel ball lever knob

Planetary action
Direct drive motor
Safety lock when the head is tilted up
Overload motor protection
10 variable speeds with Smooth Start function
Accessory port for optional accessories
4.8 lt/5 qt high-polished stainless steel bowl with ergonomic handle
Anti-slip feet

Capacities:
White eggs: max 12/ min 3
Cake dough: max 2.8 Kg/ 99 oz
Bread/pizza/pasta dough: max 1.3 Kg/ 46 oz
Whipped cream max 1lt/ 32 oz

Dimensions HxLxW:
18" x 16" x 10"
Net weight: 21 lbs
Cord length: 39"

Rating: 120V
Frequency: 60Hz
Power: 600 W

INCLUDED ACCESSORIES:

SMWW01	Stainless steel wire whisk
SMFB01	Aluminum flat beater
SMDH01	Aluminum dough hook
SMB401	4.8 Lt Stainless steel bowl
SMPS01	Pouring shield



SICILY IS MY LOVE

SMALL DOMESTIC APPLIANCES

SMALL DOMESTIC APPLIANCES

SMEG '50s Style line was born from the fusion of technology and aesthetics, functionality and evocation of the unmistakable shapes and atmosphere of '50s Style.

Rounded and retro lines and colors are reinterpreted with a modern twist to become heros of the kitchen.

From the iconic FAB28 fridge, to the latest generation of Small Domestic Appliances, the '50s Style line is composed of unique, versatile, anti-conformist products, and is dedicated to those who love being surrounded by objects with a strong character, without losing sight of high-quality performance.



ESPRESSO COFFEE MACHINES

italian style

The Italian coffee making tradition finally conquers the domestic space, enchanting all the espresso lovers. SMEG Espresso Coffee Machine can be used with both ground coffee and paper pods, allowing you to choose among your favorite coffee roasters. Bring home all the taste and aroma of the coffee served at your favorite coffee shop.

USER FRIENDLY CONTROL PANEL

3 buttons to adjust preferred settings and select single/double espresso or the activation of steam function.



THERMOBLOCK SYSTEM & 15 BAR

A unique single Thermoblock heating system speeds up activation time and rapidly heats the water, and 15 bar pressure helps create the very best experience.

DESCALE INDICATOR

The machine will alert you when descaling is required.

REMOVABLE CUP TRAY

The steel cup tray can be removed for easy cleaning and to accommodate taller glasses.

CAPPUCCINO SYSTEM

Mix steam, air, and milk in a small beaker to prepare a thick and rich foam for your cappuccino. The wand can be adjusted in different positions.

FILTER HOLDER

Stainless steel filter holder with 3 filters included (single, double, paper pods).

DRIP COFFEE MACHINE

style has a new flavor

Filter (or 'Americano') coffee is a pleasure to be savored slowly, and is often associated with the idea of a long, relaxing break: the ideal companion for a day at work with your cup on your desk, to be enjoyed at breakfast or lunch, or to take with you when you leave the house - a pleasant companion to combat the hustle and bustle of your day.



KETTLE

quick to the boil

With its mix of technology and slightly retro style, the '50s Style kettle makes every moment special, from breakfast, to afternoon tea, from a quick break, to relaxing in the evening. It boils water quickly, precisely, and efficiently.

LIMESCALE FILTER

Removable and washable stainless steel filter that filters out natural limescale present in water.

1.7L CAPACITY, APPROXIMATELY 7 CUPS

Large 7-cup jug capacity with a water gauge that shows the water level in both liters and cups.

STAINLESS STEEL BODY

Enamelled stainless steel surface ensures excellent heat conduction.



SOFT OPENING

A gentle opening when you push the lid open button, prevents hot water from splashing, or steam from coming out when opening.

360° SWIVEL BASE

Base with non-slip feet including electrical connection and a safety system that, in the absence of water, interrupts the operation of the unit.

variable-temperature

7 TEMPERATURE LEVELS

It is possible to regulate the temperature from 50°C to 100°C, depending on what you want to heat the water for.

KEEP-WARM OPTION

A function that enables the water to be kept at the selected temperature for up to 20 minutes.



TOASTERS

clever toasting

The SMEG toaster combines ergonomics, functionality, and aesthetic balance. Breakfast, lunch, brunch, or just snacking - when you fall in love with the SMEG '50s Style' toaster, you'll find every available excuse to use it.

2x2 slice toaster



AUTOMATIC POP-UP

When the selected toasting time has finished, the slices pop-up automatically.

CRUMB TRAY

Stainless steel tray, removable for easy cleaning.

4x2 slice toaster

2 LARGE COMPARTMENTS

Self-centering racks in the compartments to ensure even toasting of slices of bread, whatever size they may be.

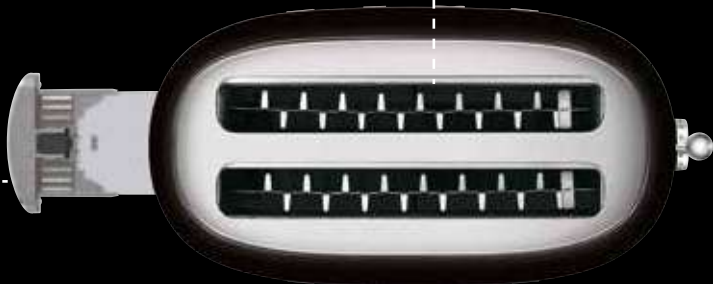

4x4 slice toaster



2 MULTI-FUNCTION INTERFACES

Select REHEAT to heat toast or slices of bread, or to continue toasting if the result was not satisfactory, DEFROST is useful for frozen slices of bread, and BAGEL will only brown one side of the bread without toasting the other.

CITRUS JUICER

color and energy

Citrus fruits are a great source of concentrated energy to help manage stress, fatigue, and seasonal changes. Drinking freshly squeezed juice is a real pick-me-up thanks to its abundant supply of vitamins which activate our immune deficiencies and help fight aging. Enjoy the pleasure of fresh and healthy juice alone or in company.

UNIVERSAL AND PREMIUM REAMER AND STRAINER

Stainless steel and anti-corrosive components ensure complete squeezing form both small and large fruit.

ANTI-DRIP SPOUT

The stainless steel spout dispenses the juice directly into the glass or cup. Lift up to interrupt the flow and prevent dripping.

Tritan™ cover to protect from dust when the product is not in use. Can be used as a bowl for fruit and peels.



PREMIUM JUICING BOWL
Made in Tritan™ BPA-free, impact resistant, easy to remove.

80W MOTOR & AUTOMATIC ON/OFF

Powerful 80 W motor with built-in sensor: the juicing process starts once there's pressure on the reamer, for easy and effortless use.



SLOW JUICER

ultimate healthy living

The SMEG slow juicer extracts juice from fruits and vegetables, seeds and nuts by crushing and then pressing them. It squeezes the ingredients without producing much heat, and keeps more of the fresh ingredients' nutrients intact, delivering a natural taste, and high nutrition standards. Whether you are sporty, interested in healthy living, want better nutrition and dietary habits, or are simply curious to try new 'real tastes', the SMEG slow juicer is a must-have item for your kitchen.

150W AC MOTOR

Strong and durable AC motor with low noise and low vibration to enhance user stability.

PREMIUM MATERIALS AND DESIGN

High quality materials (Tritan™ and Ultem™) and excellent design for safe and convenient results and easy cleaning.

EXCLUSIVE SLOW SQUEEZING TECHNOLOGY™

Second-generation technology ensures the best juice extraction experience. Slow-squeezing speed at 43 RPM preserves the taste and nutrients.

LARGE CHAMBER

Chamber built to squeeze a large amount of juice up to 500ml.

CONTROL LEVER

To adjust the thickness of your juice, and mix ingredients inside the chamber.



STAND MIXER

in the mix

A cake to offer to your friends, the unique scent of home baked bread, fresh pasta that will amaze your dinner guests - recipes take shape thanks to the SMEG '50s Retro Style stand mixer, a reliable, robust, and efficient assistant in the kitchen.

PLANETARY MOVEMENT

Planetary action provides excellent coverage of the bowl for an even mix.

VARIABLE SPEED CONTROL

10 adjustable settings guarantee the greatest versatility. The numbers printed alongside the lever suggest the correct speed based on the attachment in-use. Additionally, thanks to the SMOOTH START, after function the machine starts at a reduced speed, preventing the ingredients from coming out.

STAINLESS STEEL BOWL

The ample 1 kg/35 oz stainless steel bowl with ergonomic handle enables small and large quantities of mixtures to be prepared.

METAL BODY

The robust metal structure of the stand mixer reduces vibrations, to work in total safety.



accessories offer possibilities

SMEG offers many useful accessories which are inserted on the front of the stand mixer to form different styles of pasta from cutting to stretching fresh pasta with the 3 piece pasta set. There is also a slicer and grater, multi food grinder, ravioli maker and spaghetti cutter after "maker" to provide more possibilities when using your stand mixer.



BLENDER

smooth and nutritious

At breakfast for a healthy fruit and yogurt smoothie, after a workout to revitalize yourself with a refreshing drink, at lunch to prepare a quick and simple velouté, the SMEG blender perfectly mixes ingredients of different consistencies, for each part of the day.

TRITAN™ BPA-FREE JUG

Light, easy-to-clean jug with dishwasher-safe lid, measuring cup, and anti-splash spout. Tritan™ BPA-free plastic is also resistant to impacts, scratches and heat.

STAINLESS STEEL DUAL BLADES

Removable blades, adjustable 4 speeds (18,000 rpm) with soft start which guarantees the desired degree of mixing.

DIE-CAST ALUMINUM BODY

Robust and stable, with anti-slip feet and built-in cord wrap.



SMOOTH START & SAFETY LOCK

The SMOOTH START function begins slowly, to facilitate the mixing of the ingredients, and then accelerates to reach the selected speed. A safety lock feature prevents the blades from moving when the blender jug is not properly fitted.

3 PRE-SET PROGRAMS

ICE CRUSH to crush ice cubes, SMOOTHIE to produce dense and creamy textures, PULSE to increase the speed of the blender to your liking by pressing a button.

versatile and easy-to-use



STAINLESS STEEL BLADES WITH FLOWBLEND™

The design of the bell and the stainless steel blades creates an optimum flow that guarantees the perfect consistency of the blended ingredients with the best possible results.

STAINLESS STEEL BLENDING ARM

For maximum durability and safety. Can be easily removed to attach the accessories.

VARIABLE SPEED KNOB

The convenient speed control knob allows you to easily select the desired intensity, ensuring maximum versatility when cooking.

ACCESSORIES INCLUDED



CHOPPER



MASHER



GRADUATED
BEAKER



STAINLESS
STEEL WHISK

ECF01RDUS

'50s RETRO, ESPRESSO COFFEE MACHINE, RED



Stainless steel wrap and plastic painted housing
Stainless steel cup holder and passive cup warmer
Chrome zamak steam lever
Chrome plated base

Thermoblock heating system
1.5 bar pressure
St/steel filter holder for powdered coffee (1/2 cup) or paper pods
Anti-drip system
User-friendly control panel
Removable drip tray for mug accommodation
1L removable water tank with optional water filter
Anti-slip feet

Functions: 1-cup button; 2-cup button; Steam option
Adjustable cappuccino system
Flow Stop function to customize your coffee length
Adjustable coffee temperature
Adjustable water hardness
Hot water dispenser
Descaling light indicator
On/Off button with automatic stand-by

Dimensions HxLxW:
12" x 13" x 6"
Net weight : 11 lbs
Cord length: 39"

Rating: 120V
Frequency: 60Hz
Power: 1,300 W

INCLUDED ACCESSORIES:

3 filters (1 cup, 2 cups, paper pods)
1 measure/presser

ECF01CRUS

'50s RETRO, ESPRESSO COFFEE MACHINE, CREAM



ECF01PKUS

'50s RETRO, ESPRESSO COFFEE MACHINE, PINK



ECF01PGUS

'50s RETRO, ESPRESSO COFFEE MACHINE, PASTEL GREEN



ECF01BLUS

'50s RETRO, ESPRESSO COFFEE MACHINE, BLACK



ECF01PBUS

'50s RETRO, ESPRESSO COFFEE MACHINE, PASTEL BLUE



ECF01WHUS

'50s RETRO, ESPRESSO COFFEE MACHINE, WHITE



DCF02PGUS

'50s RETRO, DRIP COFFEE MACHINE, PASTEL GREEN



DCF02PBUS

'50s RETRO, DRIP COFFEE MACHINE, PASTEL BLUE



DCF02WHUS

'50s RETRO, DRIP COFFEE MACHINE, WHITE



Full-metal, painted housing and lid
10-cup capacity
Digital LED display and clock
User-friendly control panel
Reusable coffee filter with handle, easy to use and clean
6-cup water tank
Tank water level indicator
10-cup capacity glass carafe, with handle and lid
Anti-slip feet

On-off button
Aroma intensity function: Light or Intense
4-cup function
Auto-start mode: automatic start at a given time
Clock / Timer lever
Keep Warm function
Adjustable water hardness
Anti-drip system
Descaling alarm light indicator

Dimensions HxLxW:
17" x 13" x 11-1/2"
Net weight: 7.5 lbs
Cord length: 39"

Rating: 120V
Frequency: 60Hz
Power: 1,050 W

INCLUDED ACCESSORIES:

Measuring scoop for ground coffee

DCF02RDUS

'50s RETRO, DRIP COFFEE MACHINE, RED



DCF02CRUS

'50s RETRO, DRIP COFFEE MACHINE, CREAM



DCF02SSUS

'50s RETRO, DRIP COFFEE MACHINE, STAINLESS STEEL



DCF02BLUS

'50s RETRO, DRIP COFFEE MACHINE, BLACK



TSF01RDUS

'50s RETRO, 2X2 SLICE TOASTER, RED



Powder coated steel body
Polished chrome base
Stainless steel ball lever knob
Backlit chrome knob

2 extra-wide slots (1.4" each)
Self-centring racks
Automatic slice pop-up
Removable stainless steel crumb tray
Built-in cord wrap
Anti-slip feet

6 browning levels
3 pre-set programs: Reheat, Defrost, Bagel

Dimensions HxLxW:
10" x 15" x 9"
Net weight: 5.4 lbs
Cord length: 39"

Rating: 120V
Frequency: 60Hz
Power: 950 W

TSF01CRUS

'50s RETRO, 2X2 SLICE TOASTER, CREAM



TSF01PKUS

'50s RETRO, 2X2 SLICE TOASTER, PINK



TSF01PGUS

'50s RETRO, 2X2 SLICE TOASTER, PASTEL GREEN



TSF01WHUS

'50s RETRO, 2X2 SLICE TOASTER, WHITE



TSF01BLUS

'50s RETRO, 2X2 SLICE TOASTER, BLACK



TSF01SSUS

'50s RETRO, 2X2 SLICE TOASTER, CHROME



TSF01PBUS

'50s RETRO, 2X2 SLICE TOASTER, PASTEL BLUE



TSF01UJUS

'50s RETRO, 2X2 SLICE TOASTER, UNION JACK



TSF02PBUS

'50s RETRO, 4X2 SLICE TOASTER, PASTEL BLUE



TSF02PGUS

'50s RETRO, 4X2 SLICE TOASTER, PASTEL GREEN



TSF02SSUS

'50s RETRO, 4X2 SLICE TOASTER, CHROME



Powder-coated steel body
Polished chrome base
Stainless steel ball lever knob
Backlit chrome knob

2 extra-wide slots (36mm/1.4" each)
Self-centring racks
Automatic slice pop-up
Removable stainless steel crumb tray
Built-in cord wrap
Anti-slip feet

6 browning levels
3 pre-set programs: Reheat, Defrost, Bagel

Dimensions HxLxW:
11" x 18" x 10"
Net weight: 7.5 lbs
Cord length: 39"

Rating: 120V
Frequency: 60Hz
Power: 1,400 W

TSF02PKUS

'50s RETRO, 4X2 SLICE TOASTER, PINK



TSF02BLUS

'50s RETRO, 4X2 SLICE TOASTER, BLACK



TSF02CRUS

'50s RETRO, 4X2 SLICE TOASTER, CREAM



TSF02RDUS

'50s RETRO, 4X2 SLICE TOASTER, RED



TSF02WHUS

'50s RETRO, 4X2 SLICE TOASTER, WHITE



TSF03RDUS

'50s RETRO, 4X4 SLICE TOASTER, RED



Powder-coated steel body
Polished chrome base
Stainless steel ball lever knob
Backlit chrome knob

4 extra-wide slots (36mm/1.4" each)
2 independent control panels
Self-centring racks
Automatic slice pop-up
2 removable stainless steel crumb trays
Built-in cord wrap
Anti-slip feet

6 browning levels
3 pre-set programs: Reheat, Defrost, Bagel

Dimensions HxLxW:
14-1/2" x 14-1/2" x 10-1/2"
Net weight: 8 lbs
Cord length: 35.4"

Rating: 120V
Frequency: 60Hz
Power: 1,800 W

TSF03CRUS

'50s RETRO, 4X4 SLICE TOASTER, CREAM



TSF03PKUS

'50s RETRO, 4X4 SLICE TOASTER, PINK



TSF03WHUS

'50s RETRO, 4X4 SLICE TOASTER, WHITE



TSF03BLUS

'50s RETRO, 4X4 SLICE TOASTER, BLACK



TSF03PBUS

'50s RETRO, 4X4 SLICE TOASTER, PASTEL BLUE



TSF03PGUS

'50s RETRO, 4X4 SLICE TOASTER, PASTEL GREEN



CJF01PBUS

'50s RETRO, CITRUS JUICER, PASTEL BLUE



CJF01PGUS

'50s RETRO, CITRUS JUICER, PASTEL GREEN



CJF01BLUS

'50s RETRO, CITRUS JUICER, BLACK



Die-cast aluminum powder-coated body

Universal stainless steel strainer
Stainless steel reamer
Tritan™ lid
Anti-drip stainless steel spout
Tritan™ juicing bowl
Chrome-plated ring and inner bowl
Built-in cord wrap
Anti-slip feet
Automatic on/off

Dimensions HxLxW:
11" x 7" x 7"
Net weight: 5.64 lbs
Cord length: 39"

Rating: 120V
Frequency: 60Hz
Power: 80 W

CJF01PKUS

'50s RETRO, CITRUS JUICER, PINK



CJF01CRUS

'50s RETRO, CITRUS JUICER, CREAM



CJF01WHUS

'50s RETRO, CITRUS JUICER, WHITE



CJF01RDUS

'50s RETRO, CITRUS JUICER, RED



KLF03PBUS

'50s RETRO, KETTLE, PASTEL BLUE



KLF03PGUS

'50s RETRO, KETTLE, PASTEL GREEN



KLF03SSUS

'50s RETRO, KETTLE, CHROME



Stainless steel powder-coated body
Polished chrome base
Stainless steel ball lever knob
Stainless steel spout
Chrome handle

1.7 lt/ 7-Cup jug capacity
Soft-opening lid
Double water indication lt/Cup
Removable stainless steel limescale filter
Auto shut-off at 100°C/ 212°F
Auto shut-off when water not detected
360° swivel base
Concealed heating element
Built-in cord wrap
Anti-slip feet

Dimensions HxLxW:
10" x 11" x 9"
Net weight: 3.5 lbs
Cord length: 39"

Rating: 120V
Frequency: 60Hz
Power: 1,500 W

KLF03PKUS

'50s RETRO, KETTLE, PINK



KLF03BLUS

'50s RETRO, KETTLE, BLACK



KLF03WHUS

'50s RETRO, KETTLE, WHITE



KLF03CRUS

'50s RETRO, KETTLE, CREAM



KLF03RDUS

'50s RETRO, KETTLE, RED



KLF04RDUS

'50s RETRO, VARIABLE-TEMPERATURE KETTLE, RED



KLF04CRUS

'50s RETRO, VARIABLE-TEMPERATURE KETTLE, CREAM



KLF04BLUS

'50s RETRO, VARIABLE-TEMPERATURE KETTLE, BLACK



Stainless steel powder-coated body
Polished chrome base
Stainless steel ball lever knob
Stainless steel spout
Chrome handle

7 temperature levels (50 -100°C/106 -212°F)
Jug capacity 57 fl oz/7-cups
Soft Opening lid system
Double water indication lt/Cup
Removable st/steel limescale filter
Keep Warm function
Auto shut-off at 100°C/ 212°F
Auto shut-off when water not detected
360° swivel base
Concealed heating element
Built-in cord wrap
Anti-slip feet

Dimensions HxLxW:
10" x 11" x 9"
Net weight: 4 lbs
Cord length: 39"

Rating: 120V
Frequency: 60Hz
Power: 1,500 W

KLF04PKUS

'50s RETRO, VARIABLE-TEMPERATURE KETTLE, PINK



KLF04SSUS

'50s RETRO, VARIABLE-TEMPERATURE KETTLE, CHROME



KLF04WHUS

'50s RETRO, VARIABLE-TEMPERATURE KETTLE, WHITE



KLF04PGUS

'50s RETRO, VARIABLE-TEMPERATURE KETTLE, PASTEL GREEN



KLF04PBUS

'50s RETRO, VARIABLE-TEMPERATURE KETTLE, PASTEL BLUE



KETTLES

SMALL DOMESTIC APPLIANCES

SJF01RDUS

'50s RETRO, SLOW JUICER, RED



SJF01CRUS

'50s RETRO, SLOW JUICER, CREAM



SJF01BLUS

'50s RETRO, SLOW JUICER, BLACK



Plastic body and hopper
Stainless steel cycle activation/Reverse function ball lever

Slow Squeezing Technology (SSTTM)
Rotations: 43 rpm
Juice density regulation lever
500 ml/17 oz juice collector bowl in TRITAN™
Auger and strainer rotating brush in ULTEM™*
Strainer rotating brush with 4 brushes, 2 of those in silicon material for a pure juice
'Reverse' function
Anti-slip feet
*Ultem is a SABIC trademark

Dimensions HxLxW:
17" x 13" x 15"
Net weight: 16 lbs
Cord length: 39"

Rating: 120V
Frequency: 60Hz
Power: 150 W

INCLUDED ACCESSORIES:

2 strainers (fine and coarse)
1 pusher
1 juice container (1 L/32 Oz)
1 pulp container (1.6 L/54 Oz)
2 cleaning brushes
Recipe book containing 12 recipes and recommendations

SJF01PBUS

'50s RETRO, SLOW JUICER, PASTEL BLUE



BLF01RDUS

'50s RETRO, BLENDER, RED



BLF01CRUS

'50s RETRO, BLENDER, CREAM



BLF01BLUS

'50s RETRO, BLENDER, BLACK



Die-cast aluminum powder-coated body
Backlit chrome knob

1.5 lt/ 48 oz/ 6-Cup Tritan™ BPA-Free jug
Transparent lid with measuring cup
Stainless steel dual blades, detachable
Safety lock when removing blender jug
Overload motor protection
Motor with Smooth Start function
Built-in cord wrap
Anti-slip feet

4 speeds
3 preset programs: smoothie, ice crush, pulse

Dimensions HxLxW:
10" x 14" x 11"
Net weight: 8.8 lbs
Cord length: 39"

Rating: 120V
Frequency: 60Hz
Power: 600 W

BLF01PKUS

'50s RETRO, BLENDER, PINK



BLF01SVUS

'50s RETRO, BLENDER, SILVER



BLF01WHUS

'50s RETRO, BLENDER, WHITE



BLF01PGUS

'50s RETRO, BLENDER, PASTEL GREEN



BLF01PBUS

'50s RETRO, BLENDER, PASTEL BLUE



HBF02CRUS

'50s RETRO, HAND BLENDER, CREAM



Stainless steel blades
Variable speed knob
Turbo function
On/Off button
Ergonomic and anti-slip handle
Power: 350 W

Stainless steel blending arm

INCLUDED ACCESSORIES:

BEAKER

1.4 Lt/47oz BPA-free Tritan™ beaker with detachable BPA-free Tritan™ lid cover with gasket
Water level marking in liters-mm/oz-cups
Ergonomic handle for easy handling
Dishwasher-safe

CHOPPER

Main container in BPA-free Tritan™ 0.5 Lt/17oz capacity
Upper lid in the same color as the hand blender main body

Stainless steel S-shaped blade with different heights
Anti-slip grey bottom cover which can be used as container lid for storing ingredients
Container & blades dishwasher-safe (not cover)

POTATO MASHER

Plastic body and detachable gear box in the same color as the hand blender main unit
Plastic blades in grey color, which slowly operate to mash potatoes or other boiled vegetables
Blades are dishwasher-safe

WHISK

Stainless steel whisk
Plastic adaptor in the same color, as the hand blender main unit
Whisk is dishwasher-safe (not the adaptor).

HBF02PBUS

'50s RETRO, HAND BLENDER, PASTEL BLUE



HBF02BLUS

'50s RETRO, HAND BLENDER, BLACK



HBF02RDUS

'50s RETRO, HAND BLENDER, RED



HBF01RDUS

'50s RETRO, HAND BLENDER, RED



Stainless steel blades with system
Variable speed knob
Turbo function
On/Off button
Ergonomic and anti-slip handle
Power: 350 W

Stainless steel blending arm



HBF01BLUS Black
HBF01PBUS Pastel Blue
HBF01CRUS Cream

SMF01PBUS

'50s RETRO, STAND MIXER, PASTEL BLUE



SMF01PGUS

'50s RETRO, STAND MIXER, PASTEL GREEN



SMF01SVUS

'50s RETRO, STAND MIXER, SILVER



Die-cast aluminum body
Zinc-alloy base with stainless steel bowl lock
Stainless steel ball lever knob

Planetary action
Direct drive motor
Safety lock when the head is tilted up
Overload motor protection
10 variable speeds with Smooth Start function
Accessory port for optional attachments
4.8 lt/5 qt high-polished stainless steel bowl with ergonomic handle
Anti-slip feet

Capacities:
White eggs max: 12/ min 3
Cake dough max: 99 oz
Bread/pizza/pasta dough max: 46 oz
Whipped cream max: 32 oz

Dimensions HxLxW:
18" x 16" x 10"
Net weight: 21 lbs
Cord length: 39"

Rating: 120V
Frequency: 60Hz
Power: 600 W

INCLUDED ACCESSORIES:

- SMWW01 Stainless steel wire whisk
- SMFB01 Aluminium flat beater
- SMDH01 Aluminium dough hook
- SMB401 4.8 lt stainless steel bowl
- SMPS01 Pouring shield

SMF01PKUS

'50s RETRO, STAND MIXER, PINK



SMF01BLUS

'50s RETRO, STAND MIXER, BLACK



SMF01CRUS

'50s RETRO, STAND MIXER, CREAM



SMF01RDUS

'50s RETRO, STAND MIXER, RED



STAND MIXERS

SMALL DOMESTIC APPLIANCES

TSSR02 OPTIONAL ACCESSORY
SANDWICH RACK (4-SLICE TOASTER)



For TSF02 toaster.

TSBW02 OPTIONAL ACCESSORY
BUN WARMER (4-SLICE TOASTER)

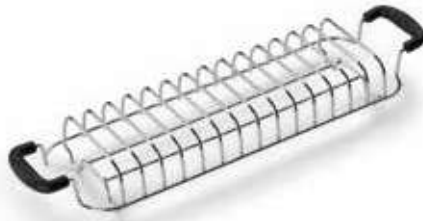

For TSF02 toaster.

TSSR01 OPTIONAL ACCESSORY
SANDWICH RACK (2-SLICE TOASTER)



For TSF01 and TSF03 toasters.

TSBW01 OPTIONAL ACCESSORY
BUN WARMER (2-SLICE TOASTER)



For TSF01 and TSF03 toasters.

HBHD01 OPTIONAL ACCESSORY
HAND BLENDER HOLDER



Hand blender holder for HBF01 and HBF02.

BGF01 OPTIONAL ACCESSORY
BOTTLE-TO-GO



600 ml/ 20 fl oz BPA-free Tritan™ bottle.
Tritan™ bottle cover with grey silicon seal for spout.
BPA-free Tritan™ cap with spout, and grey silicon seal.
Detachable stainless steel blade with safety lock.
Body, cover, cap dishwasher-safe.

SMDH01 OPTIONAL ACCESSORY
DOUGH HOOK



Aluminum dough hook to combine and mix leavened doughs, such as those for pasta and pizza, in the best possible way.

SMFB01 OPTIONAL ACCESSORY
FLAT BEATER



Aluminum flat beater to combine dense mixtures such as those for cakes, frosting, biscuits, and purées.

SMWW01 OPTIONAL ACCESSORY
WIRE WHISK



Stainless steel wire whisk to whip up egg whites, yolks, cream, and make custards and sauces.

SMB401 OPTIONAL ACCESSORY
STAINLESS STEEL BOWL



1 kg/35 oz polished stainless steel bowl with ergonomic handle. Dishwasher-safe.

SMPS01 OPTIONAL ACCESSORY
POURING SHIELD



The pouring shield prevents splashes coming out, and, at the same time, its spout simplifies the addition of ingredients during mixing.

SMMG01 OPTIONAL ACCESSORY
MULTI-FOOD GRINDER



3 discs for mincing (coarse, medium, fine) and a silicon disc for cleaning. Body in aluminum alloy. 3 discs in stainless steel for mincing/grinding: Coarse Ø 8 mm, Medium Ø 4.2 mm, Fine Ø 3 mm.

SMSG01 OPTIONAL ACCESSORY
SLICER & GRATER



4 drums for slicing and grating. Body in plastic, drums in stainless steel. The rotor design allows you to grate and slice directly into a serving bowl.

SMPC01 OPTIONAL ACCESSORY

PASTA ROLLER AND CUTTER SET



Pasta roller, tagliolini cutter, and fettuccine cutter. Chrome steel body. Chrome steel.

SMPRO1 OPTIONAL ACCESSORY

PASTA ROLLER



Thanks to the control knob, it is possible to select up to 10 different lengths in the rollers to stretch the dough into sheets 140 mm wide. Chrome steel.

SMRM01 OPTIONAL ACCESSORY

RAVIOLI MAKER



Thanks to its two rollers, it's even easier to prepare your own fresh ravioli in the comfort of your home. Chrome steel body.

SMFC01 OPTIONAL ACCESSORY

FETTUCCINE CUTTER



With this accessory it is possible to cut fettuccine 6mm wide. Chrome steel.

SMTCO1 OPTIONAL ACCESSORY

TAGLIOLINI CUTTER



A useful tool to easily create tagliolini 1.5 mm wide. Chrome steel.

SMSC01 OPTIONAL ACCESSORY

SPAGHETTI CUTTER



With the spaghetti attachment, it is possible to transform fresh sheets of pasta into spaghetti just 2 mm in diameter. Chrome steel.

TECHNICAL DRAWINGS

Thank you for specifying SMEG major appliances! In this section, and throughout this brochure, you will find overall appliance and build-in measurement data. This information is provided as a guideline as you contemplate form, fit, and function. As with any printed matter, we are unable to communicate updates therefore we strongly urge you to visit our website, www.smegusa.com, to download the most up-to-date specifications before cutting countertops or finalizing your kitchen designs to ensure you have the most current specification.

PRO RANGES

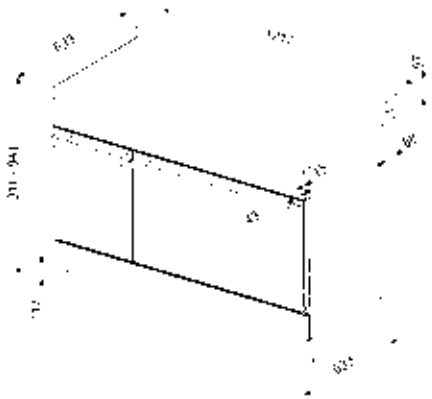

CPF48UGM

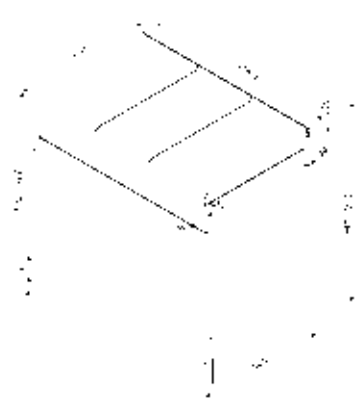

CPF36UGM/CPF36UGG

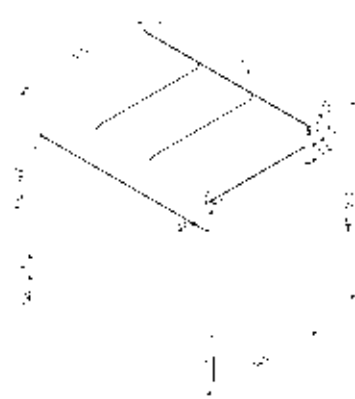

CPF30UGM/CPF30UGG



A3XU7



TRU36

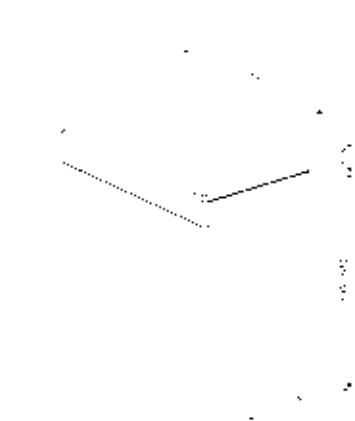

TRU90

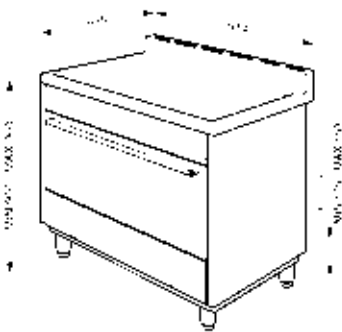

C36GGXU

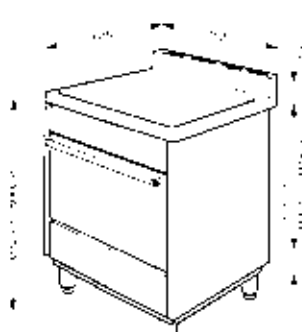

C30GGXU

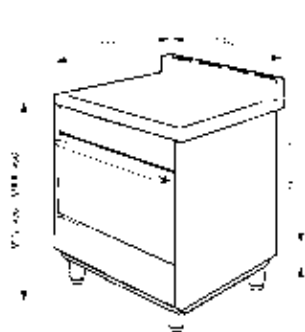

C24GGXU

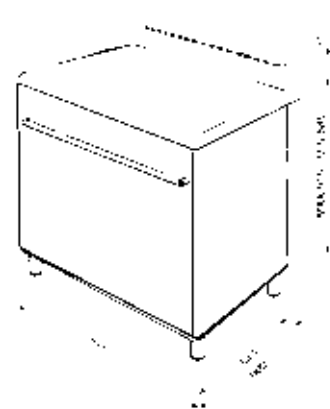

S9GMXU9

VENTILATION HOODS



KPF48



KPF36

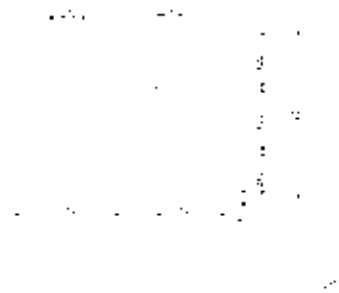

KPF30



KTU36

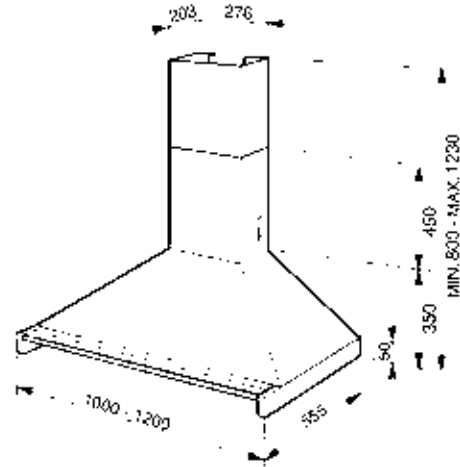

KD120XU

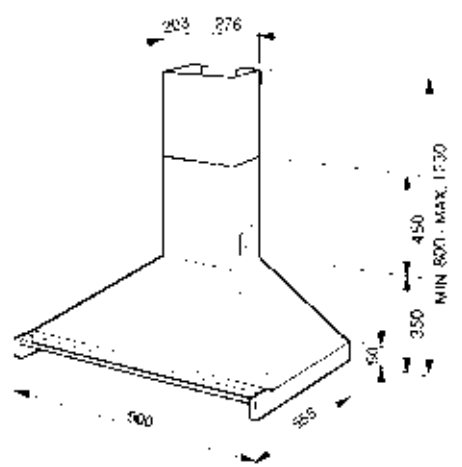

KD90XU



KDU30X

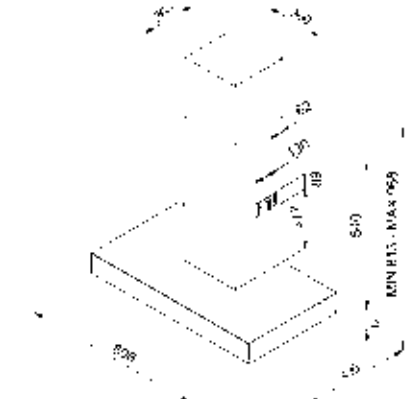

KSM36XU

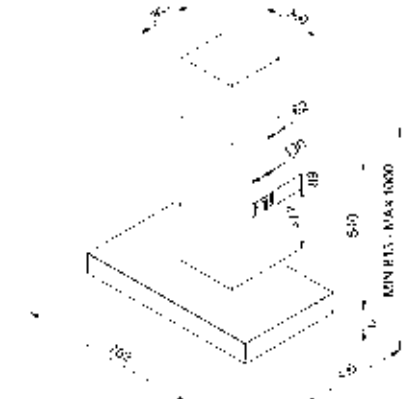

KSM30XU

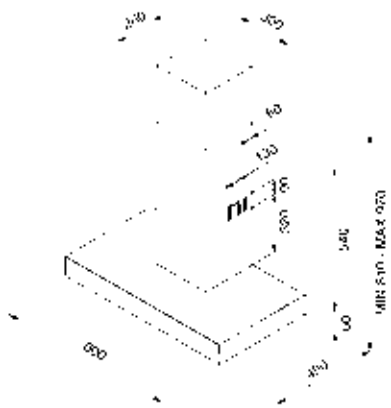

KSM24XU



KUC48X



KUC36X



KUC30X

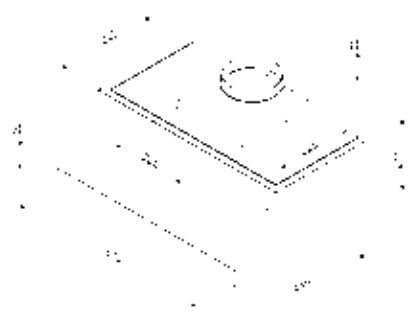

KUC24X

PIANO DESIGN LINE

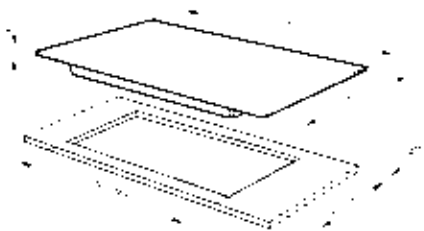

PU75ES

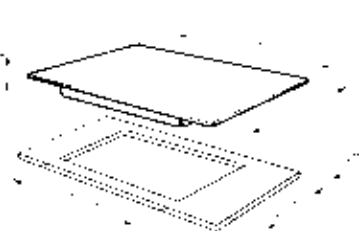

PU64ES

OVENS

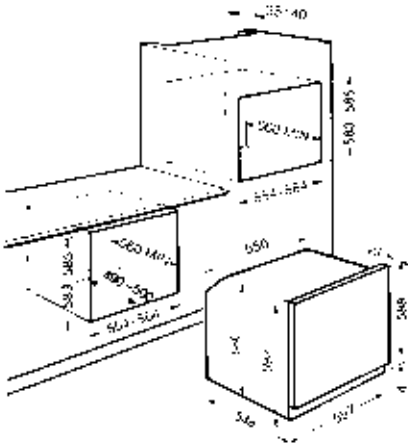

SFU6104TVS, SF112U, SFU6302TVX, SF399XU

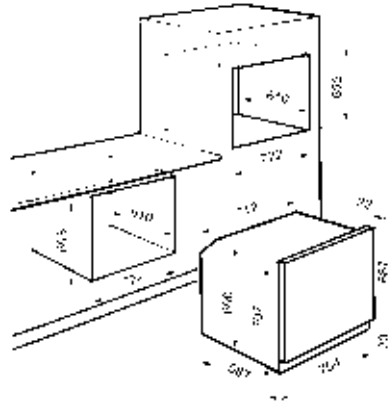

SOU130S1, SOU130S, SOU330X1

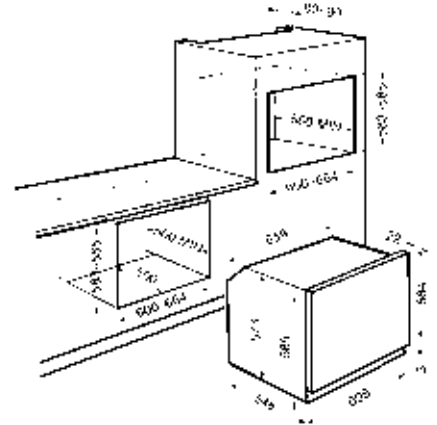

SC712U

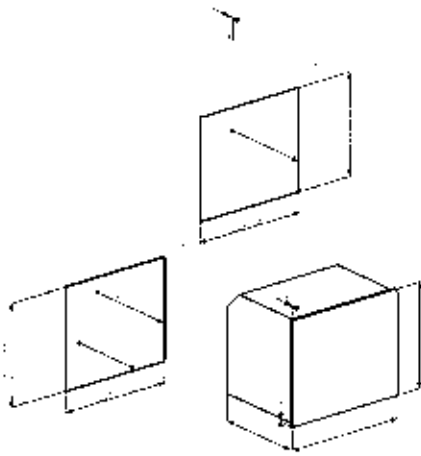

SFU7302TVX

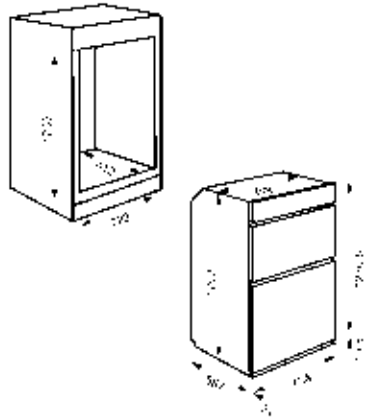

DOU330X1

COMPACT OVENS



SFU4104VCS, SF4104MCS, SF4302VCS, SFU4302MCX

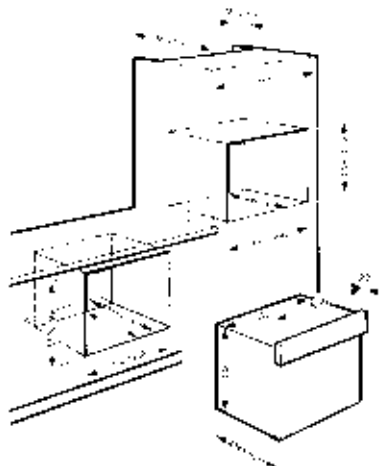

SCU45VCS1, SCU45MCS1, SU45MCX1, SU45VCX1

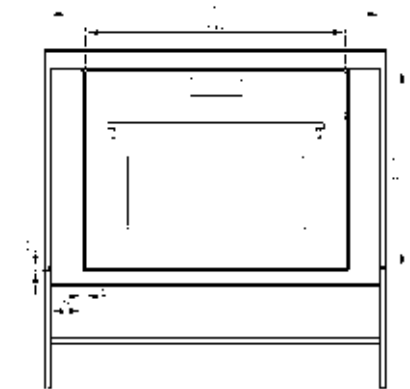

KIT130S/KIT330X

MICROWAVE OVENS

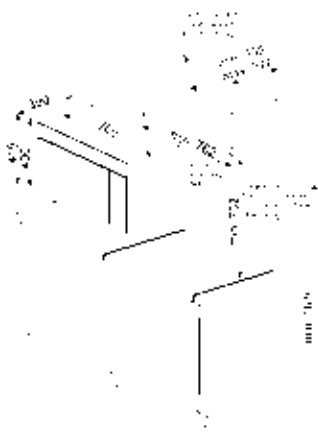

OTR111SU, OTR316XU



FMU020X

COFFEE MACHINES

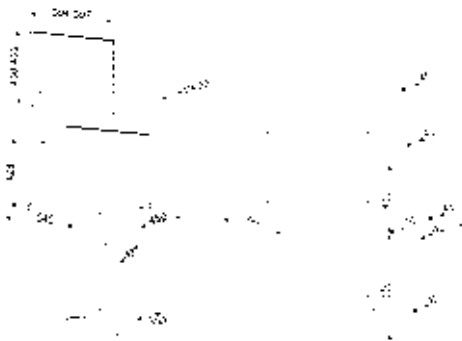

CMSU4104S, CMSU4303X

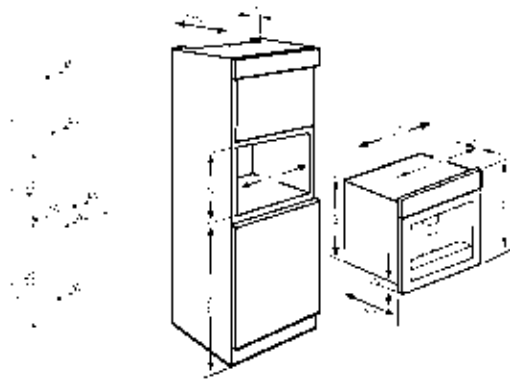

CMSCU451S, CMSU6451X

DRAWERS

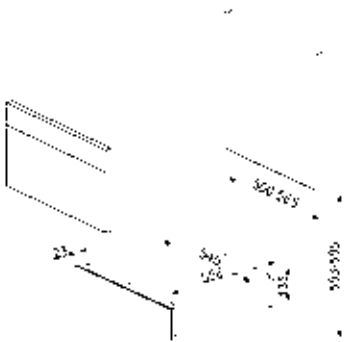

CPRU115S, CPRU315X

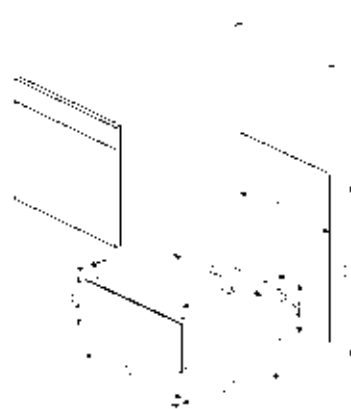

CPRU130S, CPRU330X

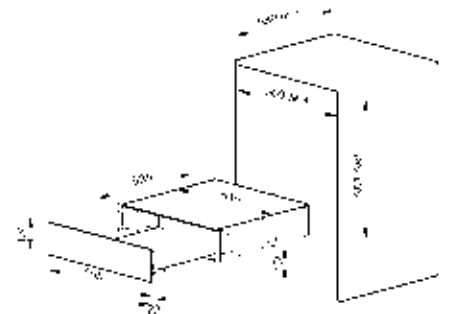

CTU15S, CTU15X

WINE COOLERS

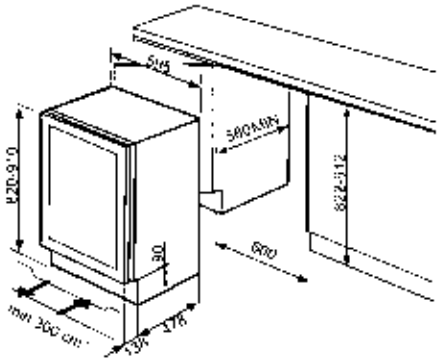

CVIU338RX



CVIU318RX

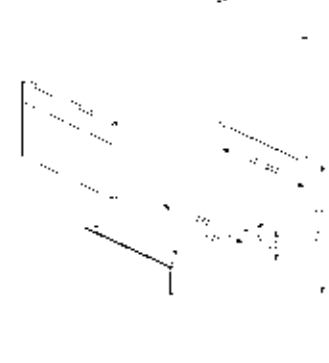

CPS315X, CP315X

COOKTOPS

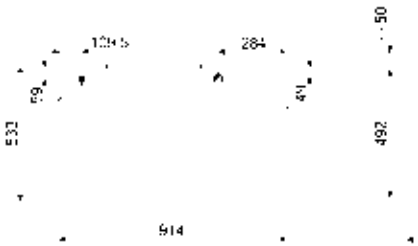

PGFU36X



PGFU30X

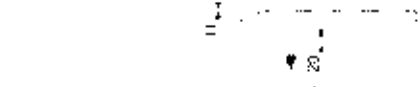

SR60GHU3

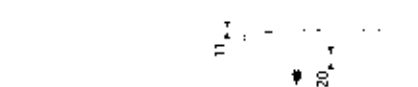

SIMU524B

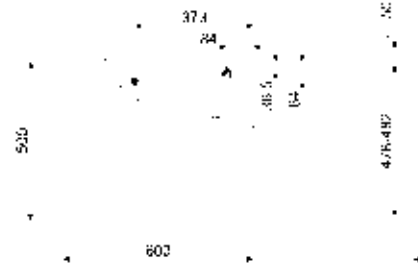

SR60GHU3



SIMU524B

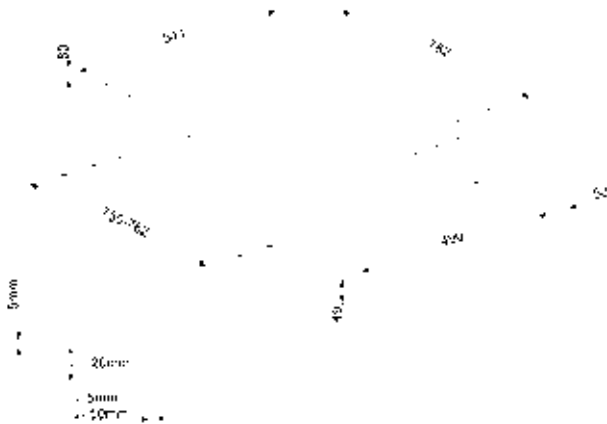

SIMU530B

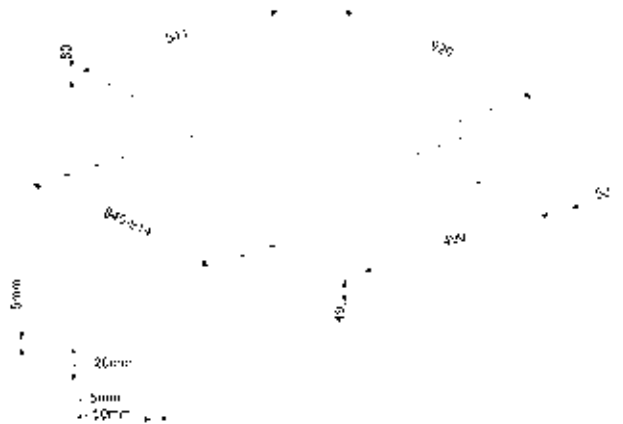

SIMU536B

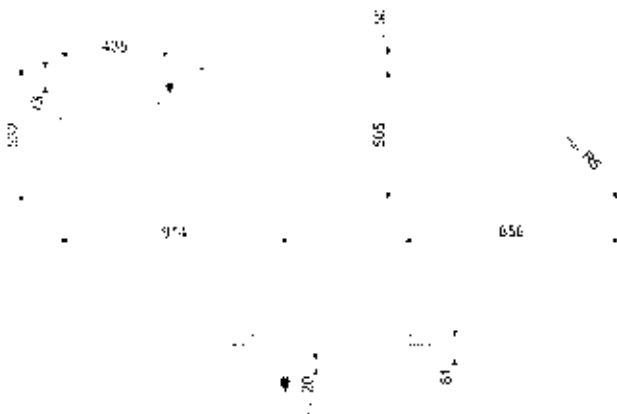

SEU365ETB

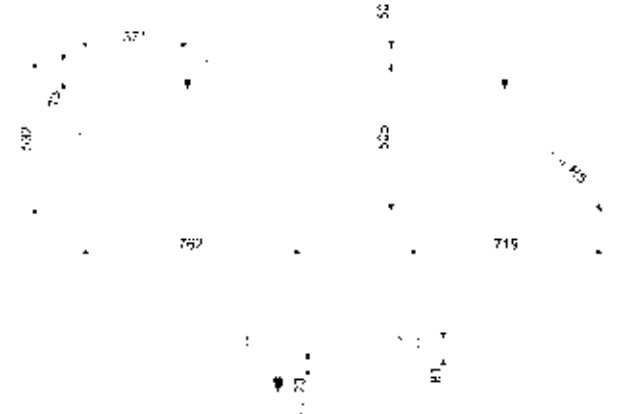

SEU304EMTB



SEU244ETB



SEU122B

DISHWASHERS

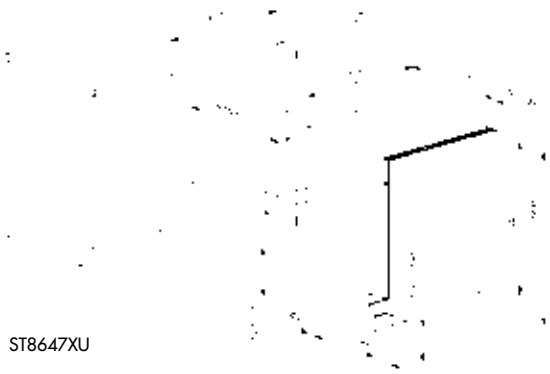

ST8647XU

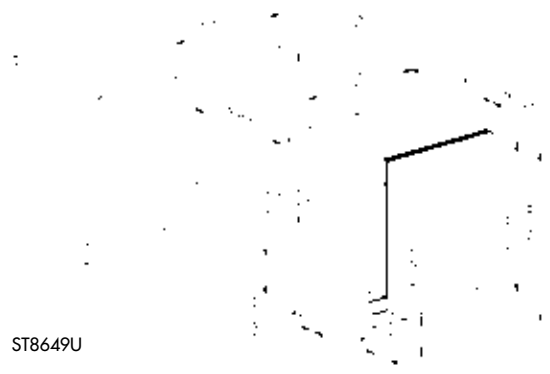

ST8649U

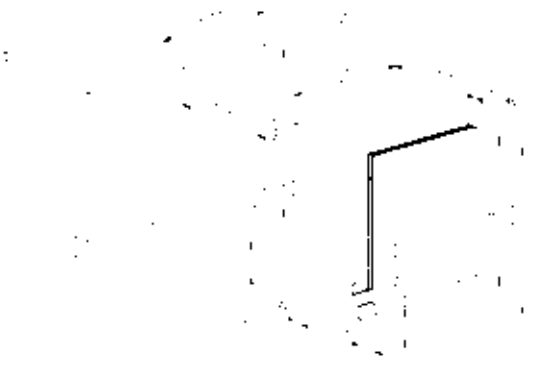

ST8642U



STU1846

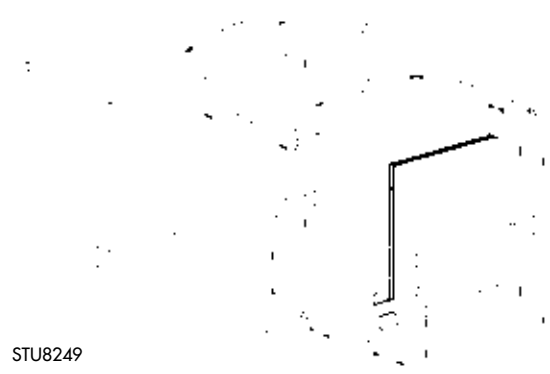

STU8249

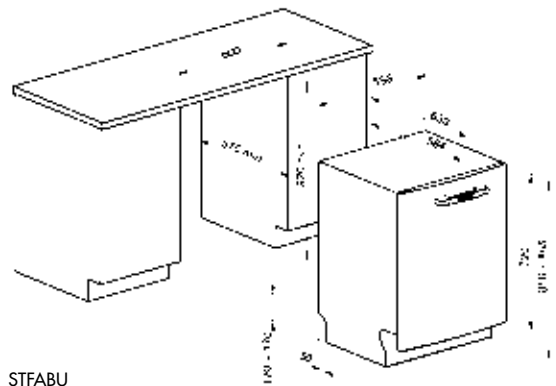

STFABU

Quality, Environmental, and Occupational Health & Safety Management Systems

All SMEG factories are ISO9001, ISO14001 and OHSAS 18001-certified, ensuring that the highest standards of quality are continually maintained, whilst actively responding to all environmental issues relating to manufacture. The materials and components used to produce SMEG products undergo strict quality control testing, and care is taken to source recyclable materials wherever possible. These management systems enable SMEG to provide complete assurance that all products meet superior standards while respecting the environment. The workforce is not forgotten – the occupational health and safety assessment scheme promotes a safe and healthy working environment, aids legislative compliance, and helps improve overall performance.



UNI EN ISO 9001



UNI EN ISO 14001



OHSAS 18001

Whereas every effort has been made to ensure that the information contained in our literature is correct at the time of going to print, this brochure should not be regarded as an infallible guide to current specification, nor does it constitute an offer for sale of any particular product.

Follow SMEG USA  

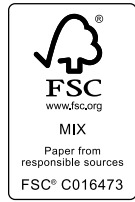

This catalogue is printed entirely on FSC® (Forest Stewardship Council)-certified paper that has been produced with cellulose sourced from forests that are managed responsibly, in accordance with rigorous environmental, social, economic, and cultural standards. <http://www.fsc.org/>



Smeg USA, Inc.

A & D Building

150 East 58th Street

7th Floor

New York, NY 10155

Ph. (212) 265 5378

www.smegusa.com

e-mail: info@smegusa.com