



*Echelon Series*

## Installation Guide



# **CO2175FF — Combo® Ice Maker/Refrigerator**

[www.U-LineService.com](http://www.U-LineService.com)

Phone (414) 354-0300 • FAX (414) 354-7905  
Service & Parts Tech Lines Phone (800) 779-2547 • FAX (414) 354-5696  
[OnlineService@U-Line.com](mailto:OnlineService@U-Line.com)

©2006 U-Line Corporation  
08/2006

**Contents**

Exterior Cleaning ..... 4  
 Cut-Out Dimensions ..... 4  
 Product Dimensions ..... 5  
 Door Swing/Clearances Information ..... 5  
 Reversing the Door..... 5  
 Other Site Requirements ..... 6  
 Side-By-Side Installation Instructions ..... 7  
 Custom 1/4" Door Panel Insert ..... 7  
 Full Overlay Door Panel ..... 8  
 Checking Door Alignment ..... 12  
 Adjusting Door Alignment ..... 12  
 Water Supply Connection ..... 13  
 Electrical Specifications ..... 14  
 Leveling Information ..... 14  
 Installation Tip ..... 14  
 Installation of the CO2175FF ..... 15  
 Relocating the Shelves ..... 15  
 Installation Troubleshooting ..... 15  
 Initial Start-Up ..... 16  
 Start-Up Troubleshooting ..... 16  
 Service Information ..... 17

**1 Follow Safety Precautions**

**IMPORTANT**

PLEASE READ all instructions completely before attempting to install or operate the unit.

- This unit requires connection to the water supply. Improper hook-up can result in substantial property damage! If you are unsure of your ability to safely connect the water supply to the unit, consult a licensed plumber for assistance.
- This unit requires connection to a grounded (three-prong), polarized receptacle that has been placed by a qualified electrician in accordance with applicable electrical codes.

**Safety Alert Definitions**

Safety items throughout this guide are labeled with a Danger, Warning or Caution based on the risk type:

**⚠ DANGER**

***Danger means that failure to follow this safety statement will result in severe personal injury or death.***

**⚠ WARNING**

***Warning means that failure to follow this safety statement could result in serious personal injury, or death.***

**⚠ CAUTION**

Caution means that failure to follow this safety statement may result in minor or moderate personal injury, property or equipment damage.

## General Precautions

Use this appliance for its intended purpose only and follow these general precautions along with those listed throughout this guide:

### WARNING

#### **SHOCK HAZARD — Electrical Grounding Required.**

- **Keep the unit unplugged throughout installation except during testing.**
- **Never remove the round grounding prong from the plug and never use a two-prong grounding adapter.**
- **Never use an extension cord to connect power to the unit.**
- **Always keep your working area dry.**

### CAUTION

- Use care when moving and handling the unit. Use gloves to prevent personal injury from sharp edges.
- Do not lift the unit by the door or door handle.
- Do not install the unit behind closed doors or in any way that would obstruct airflow to the front grille, which may cause the unit to malfunction.

## 2 Inspect and Plan

You have received a carton containing your CO2175FF Ice Maker/Refrigerator with a package inside containing a Use and Care Guide, a Product Registration Card and water connection parts. Complete and mail the Product Registration Card or register online at [www.U-LineService.com](http://www.U-LineService.com). Once your unit is installed, keep the Use and Care Guide and this Installation Guide in a safe place for future reference.

Your unit is Black, White or Stainless Steel. Black and White units have a reversible door with a slightly contoured handle across the top. They come with a flush mounted door panel that, when removed, will accept a custom 1/4-inch thick door panel or a 3/4-inch thick full overlay door panel. Stainless Steel units are covered with a protective coating and have been ordered left- or right-hand hinged. The Stainless doors are not reversible and do not accept custom panels. Please carefully follow the directions that apply to your unit and your intended design.

### **Tools/Materials Required**

- Screwdrivers — slotted and Phillips head
- 1/4-inch Outside Diameter copper tubing and shut-off valve for water supply line
- 1/4-inch thick door panel material and cutting tools (Black or White units) (If installing a 1/4" Panel)
- Full Overlay Door Panel Kit (part number U-OL2175B — Black or part number U-OL2175W — White), 3/4-inch door panel overlay, cutting tools, drill and bits (Black or White units) (If installing a 3/4" Full Overlay)

### **Inspection**

Unwrap and inspect the unit on a flat, level surface capable of supporting its entire weight.

### **Removing Protective Coating**

(Stainless Steel Units Only)

When inspecting/installing a Stainless Steel unit, the protective coating covering the unit must be removed first. Start at a corner of the unit/door and pull back the protective coating to remove it from the unit/door.

After all the protective coating has been removed from the unit/door, clean all Stainless Steel surfaces with Claire Stainless Steel Polish and Cleaner or comparable product or a mild detergent and warm water solution and soft cloth. Do NOT use abrasive cleaning agents.

*Note:* If cleaning with mild detergent and warm water solution and soft cloth, the unit MUST be treated with Claire Stainless Steel Polish and Cleaner or comparable product to prevent discoloration.

## Exterior Cleaning

(As Required)

### Black and White Models:

- The door, grille and cabinet may be cleaned with a mild detergent and warm water solution. Do not use solvent-based or abrasive cleaners. Use a soft sponge and rinse with clean water. Wipe with a soft, clean towel to prevent water spotting.

### Stainless Steel Models:

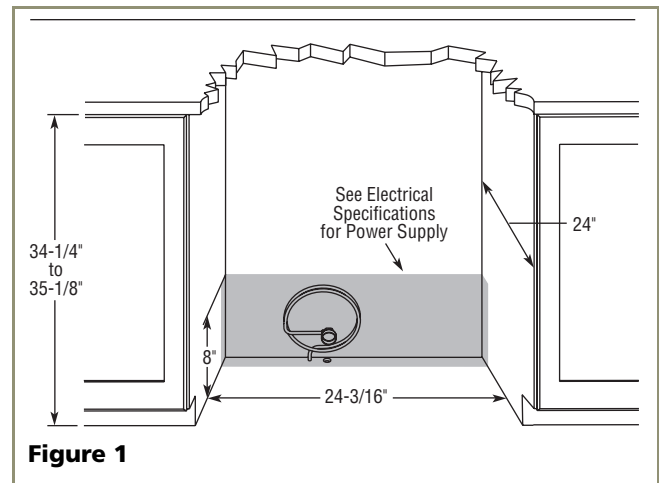
- Stainless steel models can discolor when exposed to chlorine gas, pool chemicals, salt water or cleaners with bleach.
- Keep your stainless steel unit looking new by cleaning with a good quality all-in-one stainless steel cleaner/polish on a monthly basis. For best results use Claire Stainless Steel Polish and Cleaner, which can be purchased from U-Line Corporation. (The part number is 173348.) Comparable products are acceptable. Frequent cleaning will remove surface contamination that could lead to rust. Some installations may require cleaning on a weekly basis.
- **Do not clean with steel wool pads.**
- **Do not use cleaners that are not specifically intended for stainless steel (this includes glass, tile and counter cleaners).**
- If any surface discolors or rusting appears, clean it quickly with Bon-Ami or Barkeepers Friend Cleanser and a non-abrasive cloth. Always clean in the direction of the grain. Always finish this process with Claire Stainless Steel Polish and Cleaner or comparable product to prevent further problems.
- **Use of abrasive pads such as Scotchbrite will cause the graining in the stainless to become blurred.**
- Rust that is allowed to linger can penetrate into the surface of the stainless steel and complete removal of the rust may not be possible.

## 3 Prepare Site

Your U-Line product has been designed for either free-standing or built-in installation. When built-in, your unit does not require additional air space for top, sides or rear. However, the front grille must NOT be obstructed and clearance is required for water, drain and electrical connections in the rear.

*Note:* Unit can NOT be installed behind a closed cabinet door.

## Cut-Out Dimensions



**Figure 1**

Follow the cut-out drawing in **Figure 1**. The 24-3/16" width allows 1/4" for ease in installation and removal of the unit. 24" is the cabinet depth in most installations. The unit is 23-11/16" deep including the handle on Black and White models and 23-11/16" deep including the door and *not* the handle on Stainless Steel models (see **Figure 2**).

## Product Dimensions

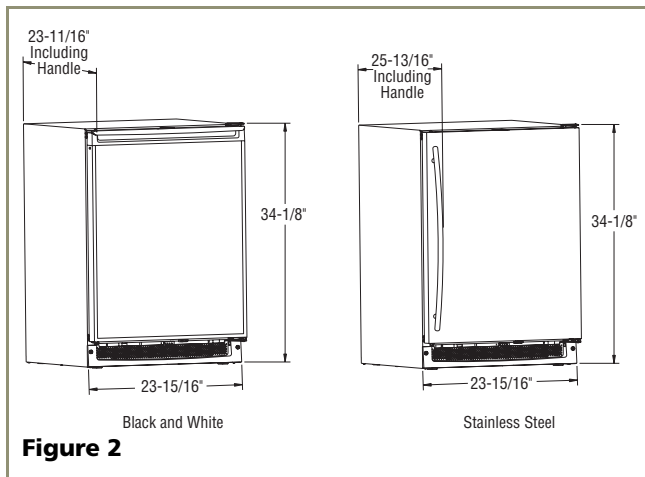


Figure 2

Please note that the unit has adjustable feet that can add one additional inch to height during leveling or to match adjacent cabinets (see **Figure 37** on **Page 14**).

## Door Swing/Clearances Information

Black and White units have a zero clearance for the door to open 90° (see **Figure 3**). Stainless Steel models require a minimum of 2-1/8\"

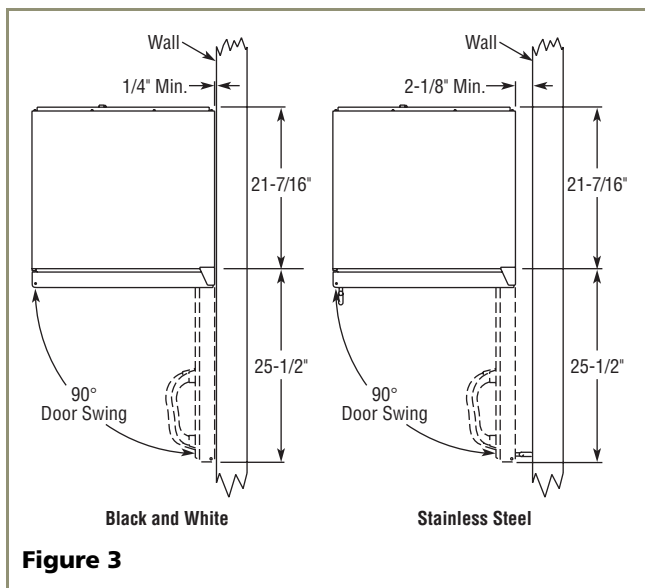


Figure 3

## Reversing the Door

(Black and White Units Only)

All U-Line units (except Stainless Steel models) may be left- or right-hand opening. The door opening is easily reversed by moving the hinge hardware to the opposite side. The top hinge hardware will be used on the bottom of the other side and the bottom hinge hardware will be used on the top of the other side (see **Figure 4**).

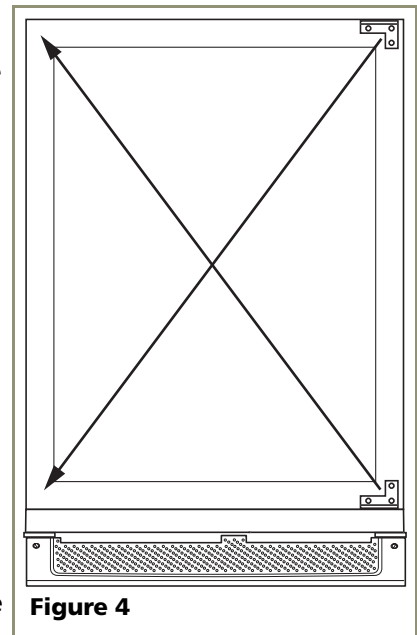


Figure 4

To reverse the door:

1. Remove top hinge screw pin from door (Phillips screwdriver) (see **Figure 5**). Remove door by tilting forward and lifting off bottom hinge pin.
2. Remove plastic screw plugs (3 each, top and bottom) from new hinge location. Do not discard (see **Figure 6**).

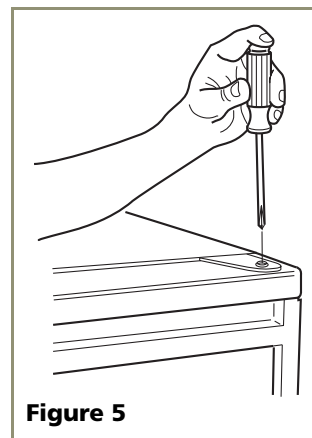


Figure 5

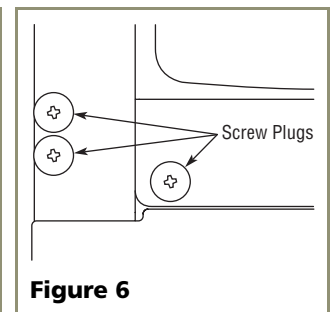
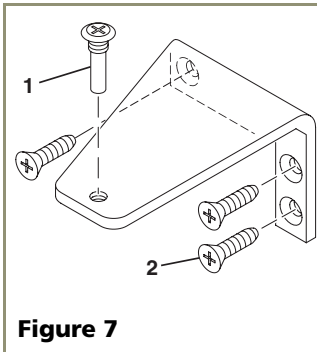


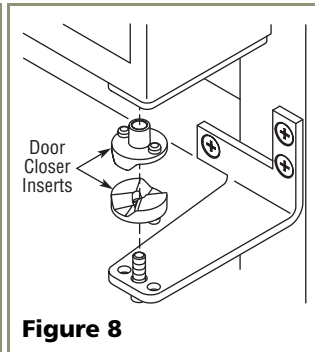
Figure 6

3. Remove top hinge (3 screws), reinstall hinge screw pin, and remount on opposite side BOTTOM (see **Figure 7**).

- Remove the two door closer inserts from the existing bottom hinge and install as shown on the new bottom hinge (see **Figure 8**).

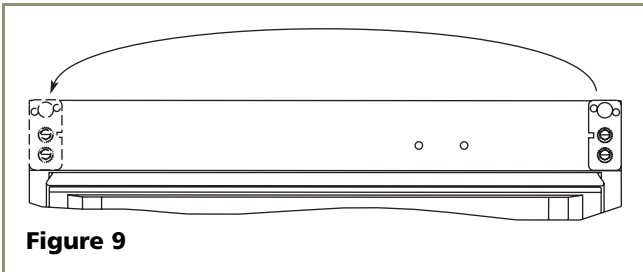


**Figure 7**



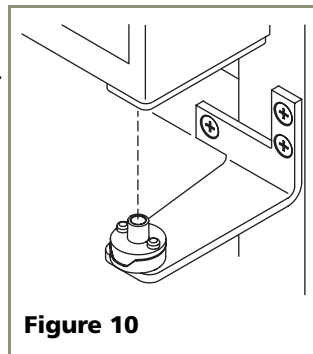
**Figure 8**

- Remove existing bottom hinge (3 screws) and remount on opposite side TOP. Remove hinge screw pin.
- Remove the plastic hole plug from the top of the door to allow the pivot pin to be inserted in the new location. Install the plug into the vacated hole on the opposite side.
- With bottom of door facing up, remove pivot plate (2 screws), flip over, and remount on opposite side of door (see **Figure 9**). Be sure notch in plate faces center.



**Figure 9**

- Holding door upright with top of door tilted forward, place hole of door pivot plate on bottom hinge screw pin (see **Figure 10**).
- Tilt top of door into position in top hinge and install top hinge screw pin.
- Install plastic screw plugs removed in Step 2 in old hinge holes (3 each, top and bottom).



**Figure 10**

## Other Site Requirements

### Power Supply

The unit requires a grounded and polarized 115 VAC, 60 Hz, 15A circuit (normal household current). See *Electrical Specifications* on **Page 14**.

### Water Supply

The unit requires a 1/4-inch Outside Diameter water supply line and a shut-off valve. For more information see **Page 13**.

### Environmental Requirements

Many U-Line models are designed to operate in harsh outdoor/marine environments. Special considerations include the following:

- The units are designed to operate between 50°F (10°C) and 110°F (40°C). High ambient temperatures (110°F [40°C] or higher) may reduce the unit's ability to reach low temperatures and may also reduce the ice production rate for those models with icemakers.
- If the ambient temperature is expected to drop below 45°F (7°C), drain all water from the unit to prevent freezing damage not covered by the warranty.
- For best performance, keep the unit out of direct sunlight and away from heat generating equipment.
- For best performance and life outdoors, place under a counter or provide shelter of some kind.
- In climates where high humidity and dew points are present, condensation may appear on outside surfaces. This is considered normal. The condensation will disappear when the humidity drops.

## Side-By-Side Installation Instructions

For a complete refreshment center, install your CO2175FF Ice Maker/Refrigerator beside a U-Line Drawer or Wine Captain Model (see **Figure 11** for typical cut-out). Note that each Side-By-Side Installation will be different.

- Cut-out width for a side-by-side installation is the total of the widths listed under *Cut-Out Dimensions* in each unit's Installation Guide.

For example:

Placing a CO2175FF Ice Maker/Refrigerator next to a 2115 series unit would require a cut-out width of:  
 $24\text{-}3/16" + 15\text{-}3/16" = 39\text{-}3/8"$

Placing a CO2175FF Ice Maker/Refrigerator next to a 2175 series unit would require a cut-out width of:  
 $24\text{-}3/16" + 24\text{-}3/16" = 48\text{-}3/8"$

- No trim kit is required. However, 1/4-inch space needs to be maintained between the units to ensure unobstructed door swing.
- Units must operate from separate, properly grounded electrical receptacles placed according to each unit's *Electrical Specifications*.

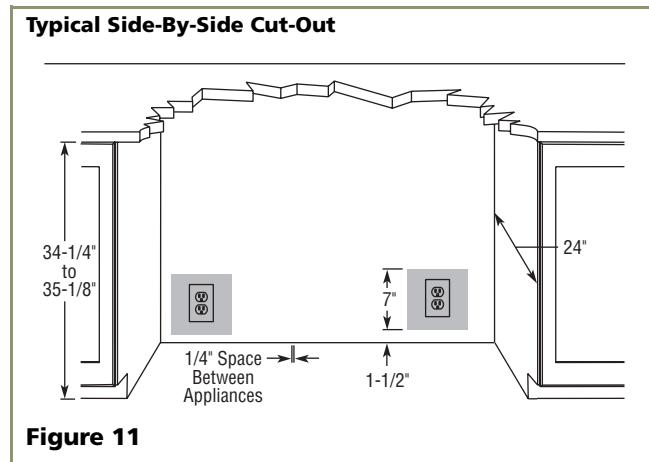


Figure 11

## 4 Prepare and Install Door Panel

(Black and White Units Only)

Two types of custom door panels can be installed on your Black or White unit to harmonize with or accent the surrounding décor: a Custom 1/4" Insert or a Full Overlay. If no custom door panel is used, go on to **5 Adjust Door**.

### Custom 1/4" Door Panel Insert

#### Door Panel Preparation

A custom door panel can be inserted into the doorframe. Custom door panels can be flat or raised, as long as the maximum panel thickness where inserted into the door reveal (channel) is 1/4" -thick. For raised panels, the depth of the reveal is 1/4" on all four sides.

#### IMPORTANT

Raised panels will reduce the door's 90° swing/zero clearance if the unit is installed next to a wall or similar type of structure.

For **2175 models** cut the panel insert to the following dimensions.

Custom 1/4" Dimensions:

Width: 23-1/32"  
 Height: 27-11/16"

For **2115 & CLR2160 models** cut the panel insert to the following dimensions.

Custom 1/4" Dimensions:

Width: 14-1/32"  
 Height: 27-11/16"

The door panel must not weigh more than 20 lbs.

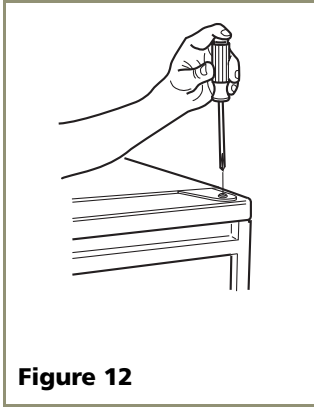
#### Door Panel Installation

Install the insert as follows:

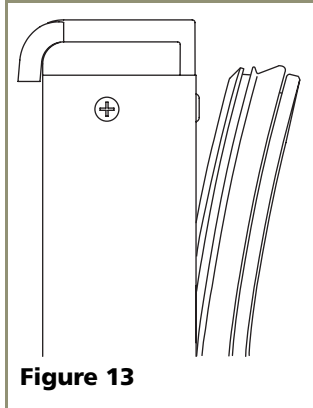
#### CAUTION

Use care when handling the insert. Insert edges may be sharp.

1. Remove top hinge screw pin (using a Phillips screwdriver, see **Figure 12**). Remove door by tilting forward and lifting off bottom hinge pin.

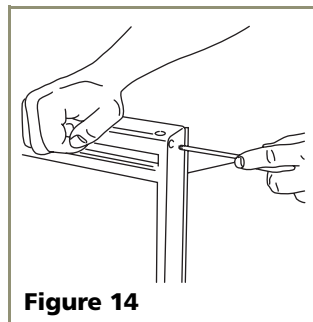


**Figure 12**



**Figure 13**

2. Pull door gasket out of groove (top edge of door only). Start in the middle and pull outward, moving toward the edge (see **Figure 13**). This may take some force.
3. Remove two outside screws holding door handle. Slightly separate door handle from door (see **Figure 14**).
4. Pull handle up and off.
5. Remove and discard existing panel and cardboard spacer.
6. Slide custom door panel insert into 1/4-inch channel in door front.
7. Holding door gasket out of the way, replace handle on door, making sure it is seated properly on insert and that screw holes line up.
8. Install two small screws removed in Step 3.
9. Starting at the corners and working inward, push door gasket into place on door.
10. Place door on bottom hinge pin and install upper hinge screw.



**Figure 14**

## Full Overlay Door Panel

### Door Panel Preparation

A full overlay door panel completely covers the doorframe and handle to give a built-in appearance. See your U-Line dealer for the optional Full Overlay Door Panel Kit.

#### 2175 Models:

P/N U-OL2175B -- Black  
P/N U-OL2175W -- White

#### 2115 & CLR2160 Models:

P/N U-OL2115B -- Black  
P/N U-OL2115W --White

Appropriate hardware, Modified Handle, Replacement Hinges and a copy of these instructions will be included in the kit.

1. Cut the overlay to the following dimensions (see **Figure 15**).

Full Overlay Dimensions:

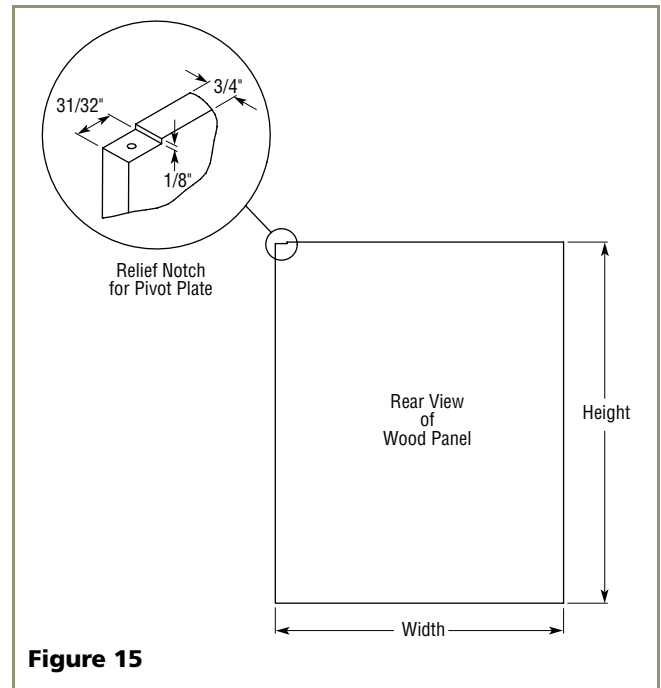
#### 2175 Models:

Width: 23-3/4"  
Height: 29-3/4"

#### 2115 & CLR2160 Models:

Width: 14-3/4"  
Height: 29-3/4"

The door panel must not weigh more than 20 lbs.

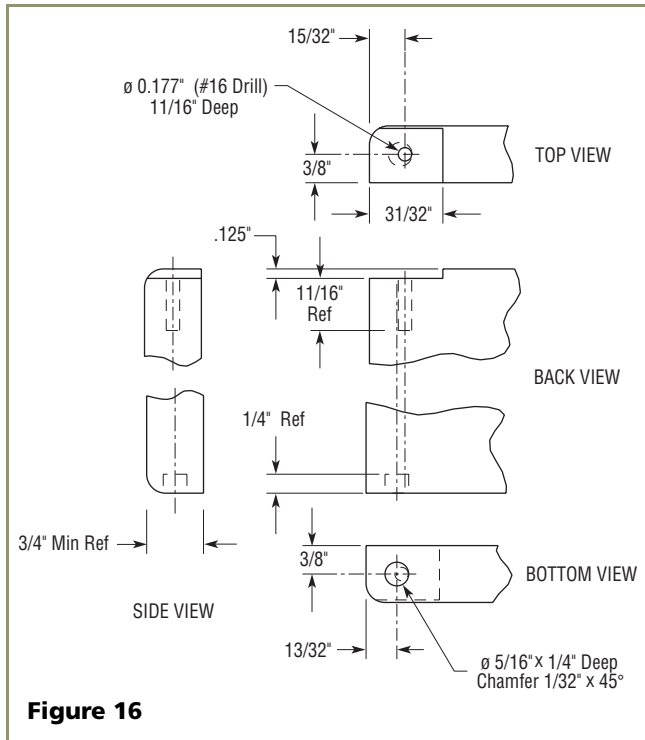


**Figure 15**

### IMPORTANT

Rear View of wood panel for right-hand hinge shown. Use mirror image for left-hand hinges.

2. Create a relief (**Figure 15**) for pivot plate by cutting notch in top corner of overlay panel. Refer to **Figure 16** for exact specifications.



**Figure 16**

Route notch in top corner of overlay panel as shown (see Top and Side Views). Top of notch is entire depth of panel, front to back.

Width: 31/32"

Depth: 1/8"

**CAUTION**

Be careful not to drill too deep! Drilling holes too deep may destroy your door panel.

3. Drill hole for upper door hinge (top of panel) (see **Figure 16**, Top View).  
0.177" diameter  
(#16 drill) x 11/16" deep
4. Drill hole for lower door hinge (see **Figure 16**, Bottom View).  
5/16" diameter x 1/4" deep

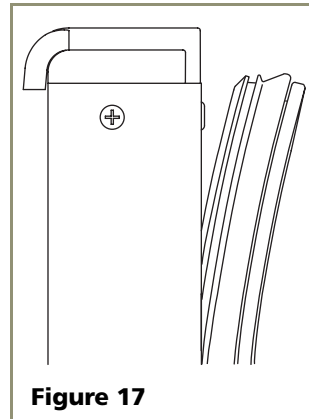
**CAUTION**

It is important to ensure that all drilled holes are drilled to the correct depth in order to avoid splits in the wood when hardware is installed.

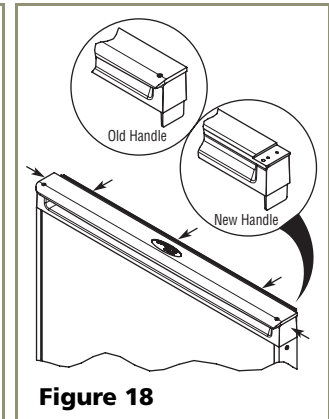
**Installation Instructions**

**Removing Existing Door**

1. Remove the door shelves by first pulling shelves up at a 45° angle, then straight out.
2. Remove top hinge screw pin (Phillips screwdriver). Remove the door by tilting forward and lifting off the bottom hinge pin.
3. Pull door gasket out of the groove (top edge of door only). Start in the middle and pull outward, moving toward the edge (see **Figure 17**). This may take some force.



**Figure 17**

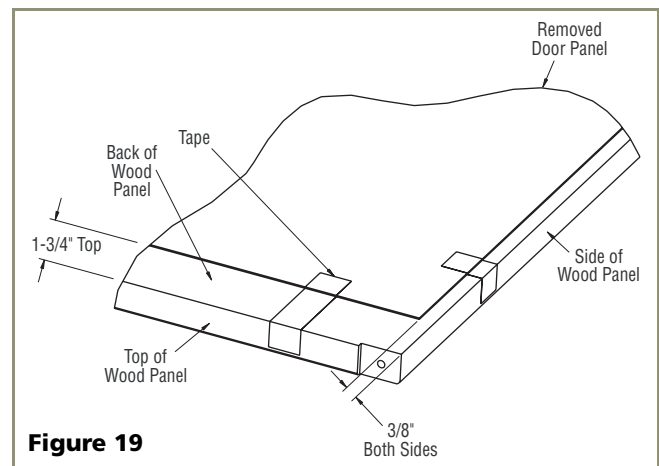


**Figure 18**

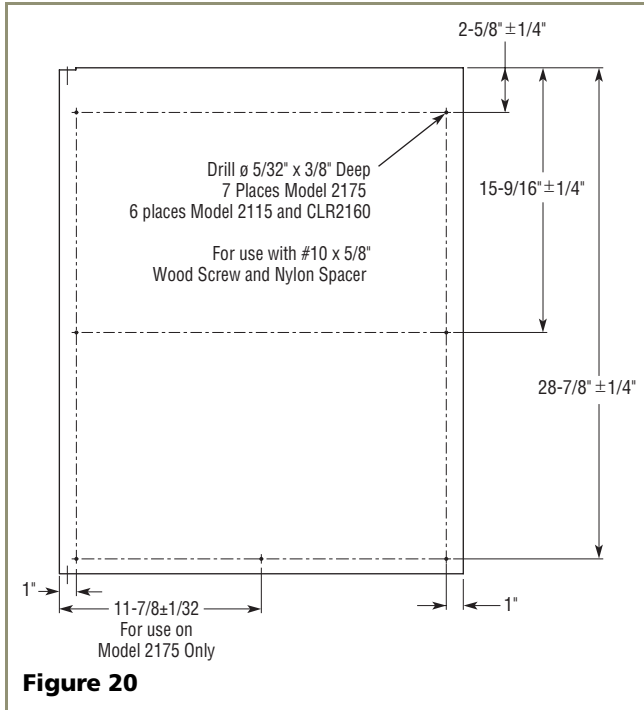
4. Remove the two screws located on both sides of the handle.
5. Remove the handle and discard. (This handle will be replaced with the Overlay Handle included in the Full Overlay Door Panel Kit.)
6. Slide the existing door panel out of the doorframe.

**Attaching the Full Overlay Panel**

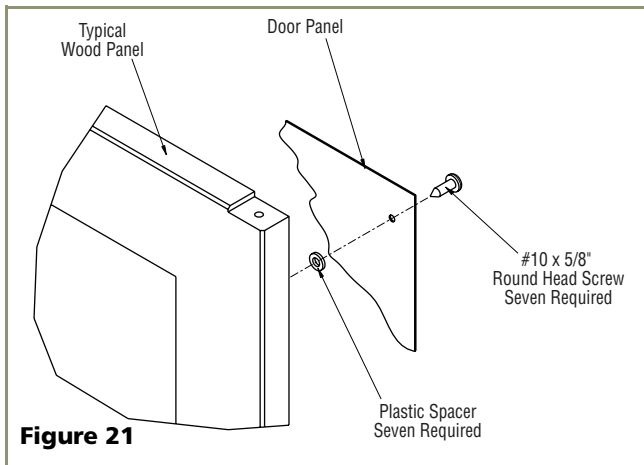
1. Place and tape the existing door panel on the back of the overlay panel (see **Figure 19**) and drill holes through both panels according to **Figure 20**. Remove tape adjoining the panels and enlarge the six holes in the steel (black/white vinyl color) panel using a 0.201" (#7) drill.
2. If a user-supplied cabinet handle will be used, attach its hardware to the overlay panel at this time.



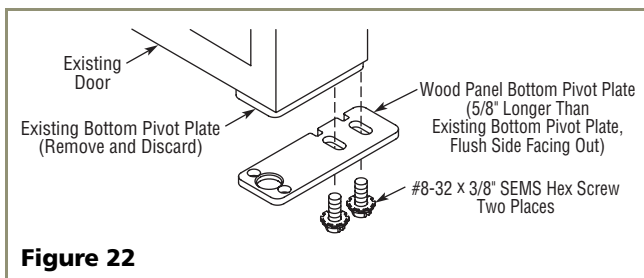
**Figure 19**



Attach the door panel to the overlay panel using #10 x 5/8" wood screws and nylon spacers. The nylon spacers fit between the overlay panel and the door panel as shown in **Figure 21**. The spacers allow the original door panel to slide back into the 1/4"-thick door reveal (channel).



3. Remove the existing bottom pivot plate and replace with the Full Overlay pivot plate (see **Figure 22**).

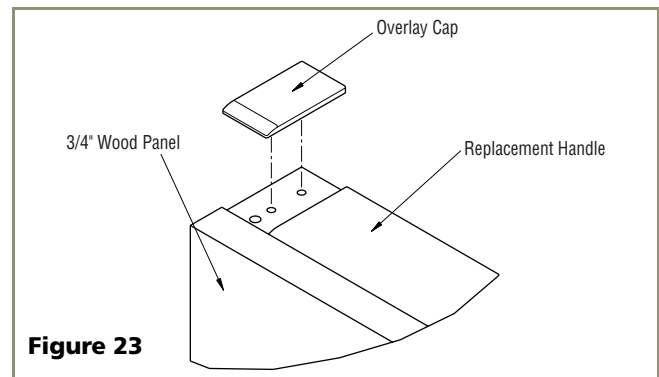


**IMPORTANT**

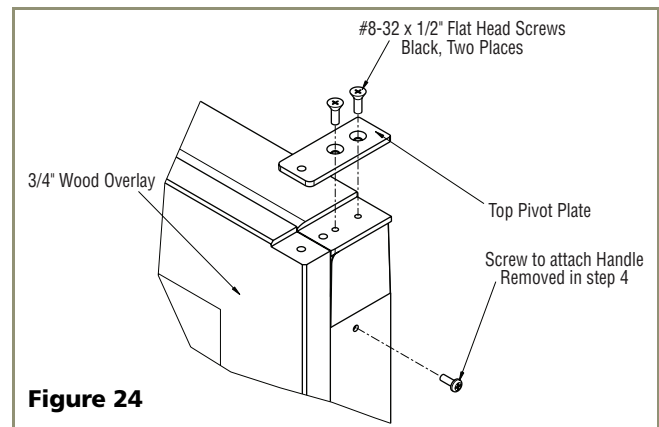
Door panel and overlay panel must be aligned properly or the door will not operate correctly.

**Assembling the Door**

1. Install the assembled panel by sliding the original door panel back into the doorframe.
2. Replace the Overlay Handle and secure with the two screws removed in Step 4 under *Removing Existing Door*.
3. Attach Overlay cap to door, opposite side of where hinges will be (see **Figure 23**).



4. Attach Top Pivot Plate to door handle, on side where hinges will be. Use the two #8-32 x 1/2" Flat Head Phillips screws (Black) supplied with kit (see **Figure 24**).



5. Starting at the corners and working toward the center, push the door gasket back into place.

**Installing the Door**

1. Remove the existing hinges from the unit, saving the door closure assembly.
2. Install the new Replacement Top Hinge onto the unit (see **Figure 25**).

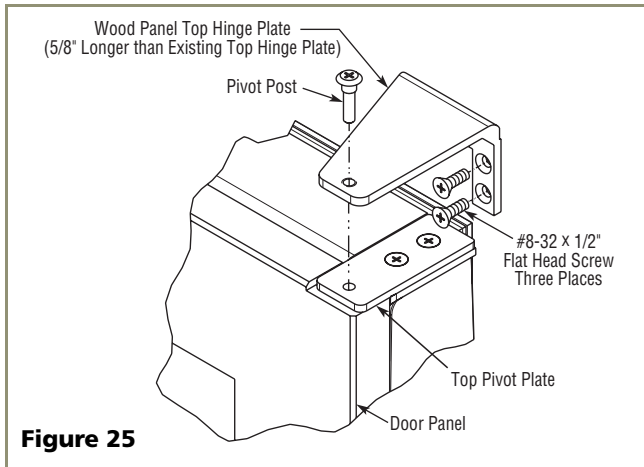


Figure 25

3. Install the pivot post into the new Replacement Bottom Hinge (using the Phillips screwdriver) and install the hinge onto the unit.
4. Replace the door closure assembly onto the bottom pivot post (see **Figure 26**). Be sure that bosses on closers align with holes in hinge and hinge plate.

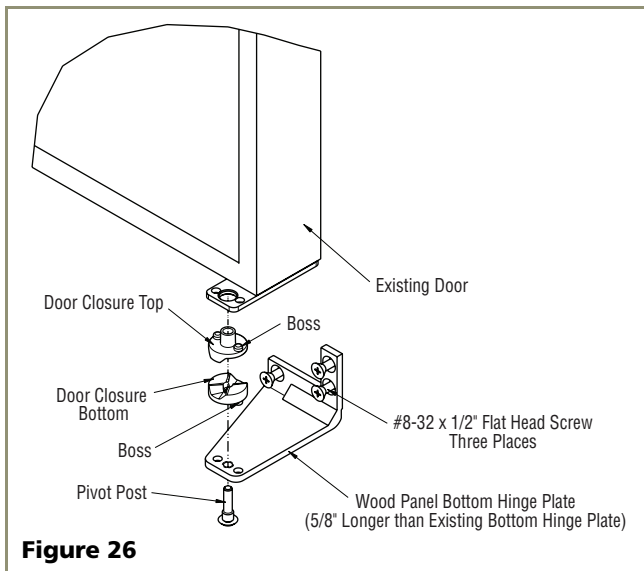


Figure 26

**IMPORTANT**

Pivot posts must be cleaned. Closers must also be clean and greased to ensure proper operation.

5. Place the modified door onto the pivot post.
6. Position door and install the pivot post into the top hinge (using the Phillips screwdriver).
7. Adjust door as needed for proper closure.
8. Check to see that light goes off when the door closes.
9. Reinstall the door shelves by lining up the bosses and first pushing straight in, then down at a 45° angle.

**Checking Door Alignment**

The unit's door is aligned at the factory before shipment. However, its alignment could have been disturbed during shipment or during door panel installation.

**IMPORTANT**

Properly aligned, the door should be 1/8" below the top of the unit's cabinet, NOT flush with the top (see **Figure 28**).

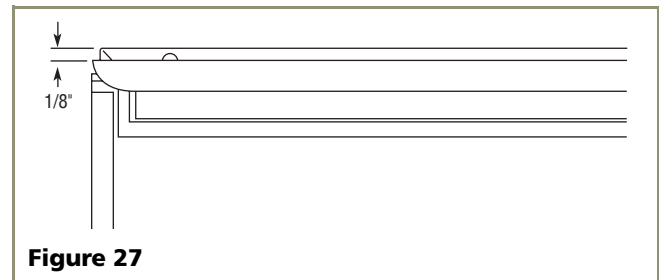


Figure 27

1. Compare the top edge of the door to the top edge of the cabinet.
2. If the door edge is 1/8" below and parallel to the top of the cabinet, the door is aligned. If it is not, note whether the side opposite the hinge needs to be moved UP or DOWN, and use the following procedure.
3. If door is adjusted correctly, but panel is not square with the adjacent cabinets, slight adjustments can be made by drilling the holes in the vinyl coated steel panel slightly oversized. See **Figure 20** on **Page 10**.

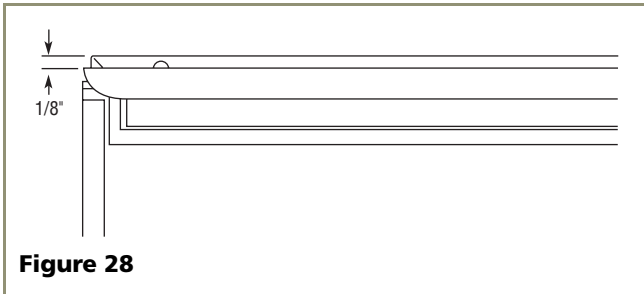
## 5 Adjust Door

### Checking Door Alignment

The unit's door is aligned at the factory before shipment. However, its alignment could have been disturbed during shipment or during door panel installation.

#### IMPORTANT

Properly aligned, the door should be 1/8" below the top of the unit's cabinet, NOT flush with the top (see **Figure 28**).



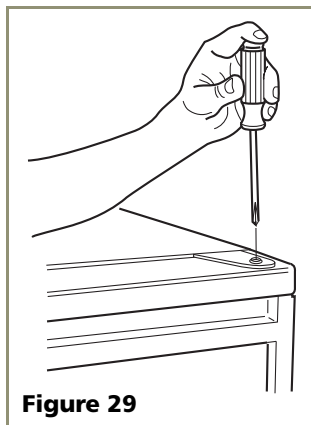
**Figure 28**

1. Compare the top edge of the door to the top edge of the cabinet.
2. If the door edge is 1/8" below and parallel to the top of the cabinet, go on to **6 Prepare Plumbing**. If it is not, note whether the side opposite the hinge needs to be moved UP or DOWN, and use the following procedure.

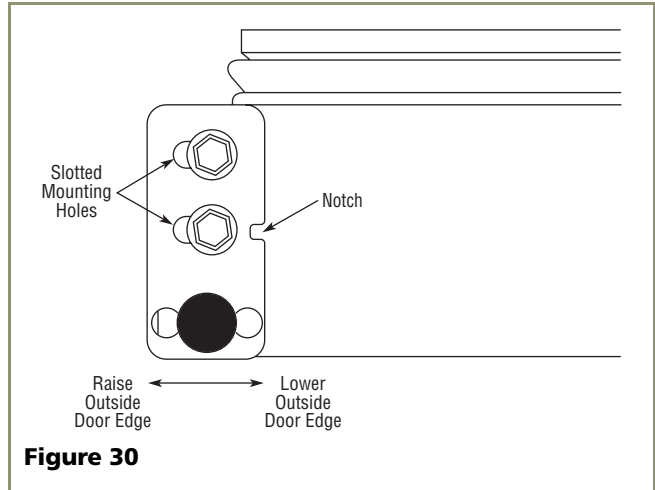
*Note:* If door is adjusted correctly, but panel is not square with the adjacent cabinets, slight adjustments can be made by drilling the holes in the vinyl coated steel panel slightly oversized. See **Figure 21** on **Page 10**.

### Adjusting Door Alignment

1. Remove top hinge screw pin (Phillips screwdriver, see **Figure 29**). Remove door by tilting forward and lifting off bottom hinge pin.
2. With door upside-down, loosen but do not remove the two screws on the door's bottom hinge plate.

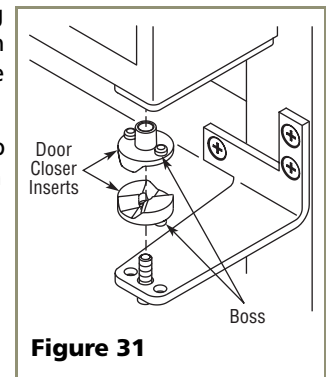


**Figure 29**



**Figure 30**

3. See **Figure 30**. If the top far edge of the door needs to move UP, move the hinge plate toward the outside of the door and retighten screws. If the top far edge of the door needs to move DOWN, move the hinge plate toward the inside of the door and retighten screws.
4. Mount the door to recheck alignment and repeat Steps 2 and 3 if further adjustment is necessary.
5. When top edge of door is parallel to top edge of cabinet, remove the door and ensure the two screws are secure.
6. Remove the door closers from the bottom hinge, clean thoroughly and lubricate the mating surfaces with petroleum jelly.
7. Reinstall the closers, lining up the bosses with holes in hinge and hinge plate (see **Figure 31**).
8. Mount the door, install top hinge pivot pin and go on to **6 Prepare Plumbing**.



**Figure 31**

## 6 Prepare Plumbing

### ⚠ CAUTION

Plumbing installation must observe all state and local codes. All water connections **MUST BE** made by a licensed/qualified plumbing contractor. Failure to follow recommendations and instructions may result in damage and/or harm.

### ⚠ WARNING

**To prevent accidental electrocution, make certain that the floor surfaces surrounding the unit are dry whenever power is removed from, or applied to, the unit.**

### Water Supply Connection

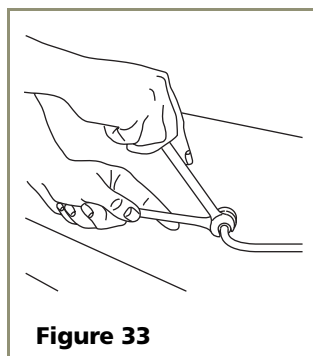
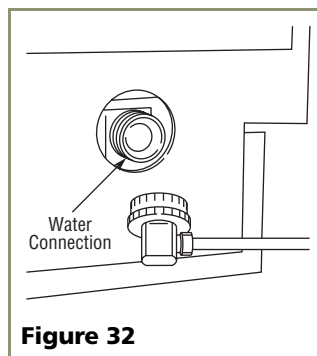
When connecting the water supply, follow these guidelines:

- Review the local plumbing codes before you install the unit.
- Connect to the cold water supply.
- The water pressure should be between 20 and 120 psi.
- Install a shut-off valve in the 1/4 inch Outside Diameter water supply line.
- Connect sufficient tubing to the unit so that tubing may be looped, allowing the unit to be removed for cleaning and servicing (see **Figure 34**). However, make certain that the tubing is not pinched or damaged during installation.

**Note: U-Line recommends the use of copper tubing for installation.** The use of other types of tubing is not recommended due to potential aftertaste & deterioration over time.

To connect to water supply:

1. Install the 1/4 inch OD copper water line from the main water source (see **Figure 32**).



2. Locate the compression fitting and ferrule packed with the unit. Slide the compression fitting and ferrule over the 1/4-inch OD water supply line. Do not use thread sealing compound or tape. Using two wrenches, tighten the compression fitting on the supply line (see **Figure 33**).
3. Carefully bend the water supply line into position and connect the line to the solenoid valve (see **Figure 34**). Avoid kinking the water supply line.

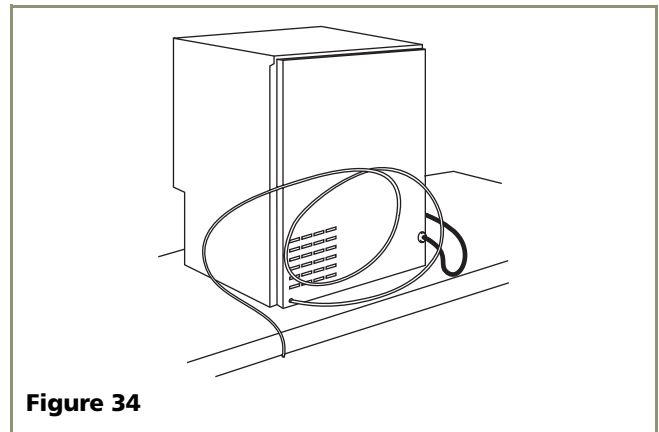


Figure 34

### IMPORTANT

Normal operation creates some vibration. A water supply line contacting cabinet wall may cause excessive noise during operation or damage to the line.

4. For recessed installations, allow extra water supply line length to provide slack for easy removal from the recessed area (see **Figure 34**). This will also safeguard against kinking the line.
5. Go on to **7 Prepare Power Supply**.

**7 Prepare Power Supply**

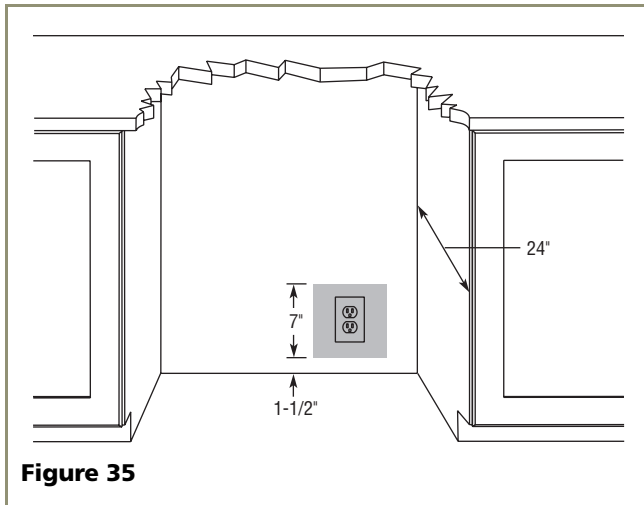
**Electrical Specifications**

**CAUTION**

Electrical installation must observe all state and local codes. This unit requires connection to a grounded (three-prong), polarized receptacle that has been placed by a qualified electrician.

The unit requires a grounded and polarized 115 VAC, 60 Hz, 15A power supply (normal household current). An individual, properly grounded branch circuit or circuit breaker is recommended. GFCI (ground fault circuit interrupter) is usually not required for fixed location appliances and is not recommended for your unit because a GFCI could be prone to nuisance tripping. However, be sure to consult your local codes.

See **Figure 35** for recommended receptacle location.



**Figure 35**

**WARNING**

**SHOCK HAZARD — Electrical Grounding Required.**

- Never remove the round grounding prong from the plug and never use a two-prong grounding adapter.
- Never use an extension cord to connect power to the unit.

Go on to **8 Level the Unit**.

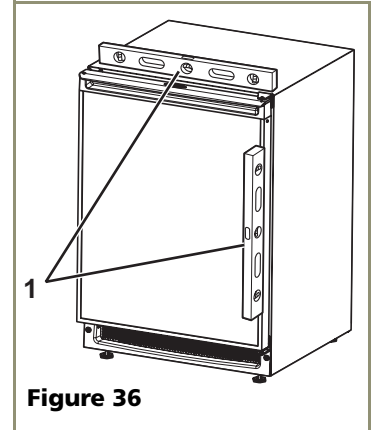
**8 Level the Unit**

**Leveling Information**

**IMPORTANT**

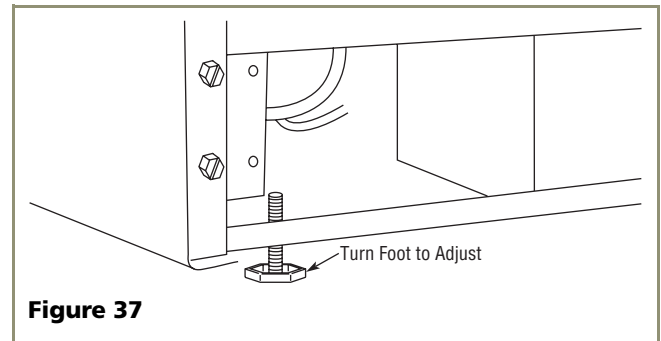
It is extremely important that the unit is level. If it is not level, the ice mold will not fill evenly.

1. Use a level to check the levelness of the ice maker from front to back and from side to side. Level should be placed along top edge and side edge as shown (see **Figure 36**).



**Figure 36**

2. If the ice maker is not level, adjust the feet on the corners of the unit as necessary (see **Figure 37**).



**Figure 37**

3. Check the levelness after each adjustment and repeat the previous steps until the unit is level. Go on to **9 Install the Unit**.

**Installation Tip**

If the room floor is higher than the floor in the cut-out opening, adjust the rear feet to achieve a total unit rear height of 1/8" less than the opening's rear height. Shorten the unit height in the front by adjusting the front feet. This allows the unit to be gently tipped into the opening. Readjust the front feet to level the unit after it is correctly positioned in the opening.

## 9 Install the Unit

### Installation of the CO2175FF

1. Open the water supply valve in the main water source.
2. Plug in the powercord.
3. Open the door and press the **POWER** icon (see **Figure 40,1**), to turn the unit **OFF**.

*Note:* If the unit is NOT turned **OFF**, water will immediately start flowing into the unit when it is first plugged into the electrical outlet.

4. Gently push the unit into position. Be careful not to kink the water supply line or entangle the electrical cord.
5. Re-check the leveling, from front to back and side to side. Make any necessary adjustments. The unit's top surface should be approximately 1/8" below the countertop.
6. Remove the tape from the glass shelves and wipe out the inside of the unit with a clean, water-dampened cloth.

### Relocating the Shelves

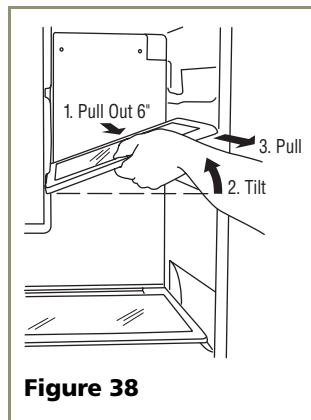
Both the glass shelves in the refrigerator and the inner door shelves can be moved to accommodate your bottles, cans and containers.

#### Glass Shelves on Right-Hand Hinge Units

1. Open door fully, grasp shelf firmly, lift front edge slightly, and pull straight out.
2. Choose new location and slide shelf onto the appropriate rib.

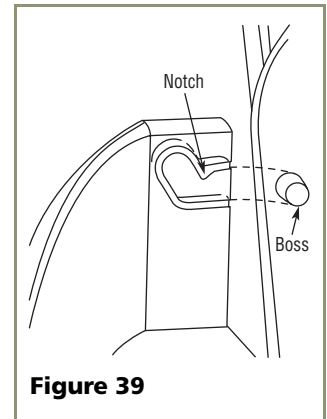
#### Glass Shelves on Left-Hand Hinge Units

1. See **Figure 38**. Pull shelf out about 6" to clear the wall's molded protrusion.
2. Tilt right-hand edge of shelf up.
3. Keeping at this angle and hugging the right wall, pull the shelf out.
4. Choose new location and insert over ribs, tilting right-hand edge up. Push in, then lower shelf onto ribs.



### Door Shelves

1. First pull shelf up at a 45° angle, then straight out (see **Figure 39**).
2. Choose new location and line up on bosses. First push straight in, then down at a 45° angle.



### Installation Troubleshooting

#### **Q:** Problem

Water is leaking under the unit.

#### **A:** Solution

A water leak under the unit is most likely caused by a bad connection in the water supply line. Make sure the water line's brass fitting is screwed tight to its valve and threaded correctly.

#### **Q:** Problem

The door remains open unless it is pushed closed.

#### **A:** Solution

The hinges should be self-closing when the door is open approximately 8". If this is not the case, make sure the closers (at the bottom of the hinge pin) are clean, greased and installed correctly. Also, re-check leveling from front to back of the unit and readjust if necessary. Make sure that pivot plate is installed correctly.

#### **Q:** Problem

The custom overlay door was designed to align with the rest of the cabinet doors, but the unit has crept forward.

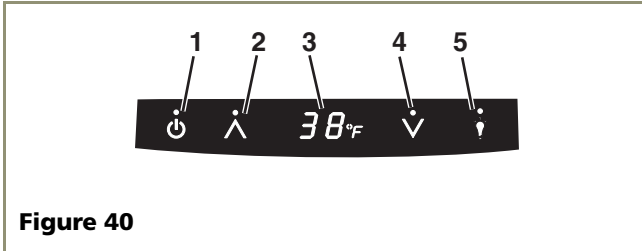
#### **A:** Solution

Make sure that the electrical cord and water supply line are not obstructing the installation.

## 10 Start-Up for the First Time

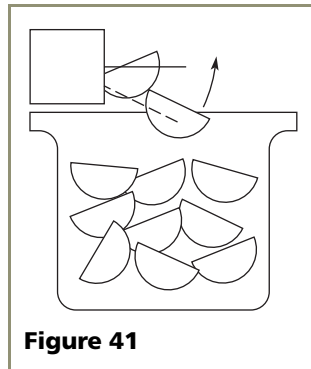
### Initial Start-Up

Once installation and leveling is complete, the unit is ready for initial start-up and operation. The **POWER** icon is located inside the unit. (see **Figure 40, 1**).



**Figure 40**

1. The unit should already be plugged into the electrical outlet. Make sure the water supply is turned on.
2. Open the door and press the **POWER** icon on the display to turn the unit on (see **Figure 40, 1**).
3. As soon as the ice maker mold reaches the proper temperature, the ice maker mechanism will fill the mold with water.



**Figure 41**

*Note:* The first cubes may be small because of air in the water line. After two hours, cubes will be standard size.

4. The ice maker will continue to produce until the bin is full. You may interrupt production by raising the bin arm into an upright and locked position (see **Figure 41**). While the bin arm is locked, the unit will maintain temperature for ice storage.

#### IMPORTANT

It is possible that dirt or scale will dislodge in the water line. Always throw away all ice cubes made during the first twenty-four (24) hours of operation.

#### ⚠ CAUTION

- The ice bucket **MUST** be fully inserted to avoid freezing products in the refrigerator section. The ice bin door must be fully closed with the door lip inside the ice bucket.
- Do not place cans or bottles so they are touching the back wall of the refrigerator section, as they may freeze.
- Do not place any objects over air inlet or outlet in the freezer section.

### About Settings

No adjustments should be necessary at this time. For information about Adjusting the Temperature Control and Adjusting the Cube Size, see the Use and Care Guide.

### Start-Up Troubleshooting

#### **Q:** Problem

Unit does not appear to turn on when **POWER** icon is pressed.

#### **A:** Solution

Make sure unit is plugged in and outlet has power (circuit breaker has not tripped). Remember that the ice maker mechanism will not fill the mold with water until the mold reaches the proper temperature.

#### **Q:** Problem

Water does not appear to be flowing into unit.

#### **A:** Solution

Check that the water is connected and turned on and the line is not obstructed.

#### **Q:** Problem

The cubes produced during the first two to three hours of operation have been discarded. New cubes still appear cloudy.

#### **A:** Solution

This is normal and is caused by air being trapped in the cube during fast freezing.

#### IMPORTANT

See the Use and Care Guide's *Troubleshooting Guide* for more solutions.

## Who to Call

### Service Information

If the need for service arises, call the U-Line Customer Care Center directly @ **800-779-2547**. To ensure accurate assistance, please have your Model Number and Serial Number and an explanation of the problem. The Model and Serial Number plate is located inside unit at upper right hand corner.

If you need to locate a service company, you can go online at **www.U-LineService.com** and search for a service company by zip code.

**For more than four decades, U-Line has distinguished itself as the leader in built-in undercounter ice making, refrigeration and wine storage appliances.**

U-Line Corporation, located in Milwaukee, WI, is a family operated manufacturer of built-in undercounter icemakers, Combo® icemaker/refrigerators, Wine Captain® wine storage units, refrigerators, refrigerated drawers and refrigerator/freezers.



*Echelon Series*

**Full Overlay Door Panel  
Preparation and Installation  
Instructions for  
2175, 2115, CLR2160 Models**

---

**[www.U-LineService.com](http://www.U-LineService.com)**

**Phone (414) 354-0300 • FAX (414) 354-7905  
Service & Parts Tech Lines Phone (800) 779-2547 • FAX (414) 354-5696  
[OnlineService@U-Line.com](mailto:OnlineService@U-Line.com)**

## Full Overlay Door Panel

### Door Panel Preparation

A full overlay door panel completely covers the doorframe and handle to give a built-in appearance. See your U-Line dealer for the optional Full Overlay Door Panel Kit.

2175 Models:

P/N U-OL2175B -- Black

P/N U-OL2175W -- White

2115 & CLR2160 Models:

P/N U-OL2115B -- Black

P/N U-OL2115W --White

Appropriate hardware, Modified Handle, Replacement Hinges and a copy of these instructions will be included in the kit.

1. Cut the overlay to the following dimensions (see **Figure 1**).

Full Overlay Dimensions:

2175 Models:

Width: 23-3/4"

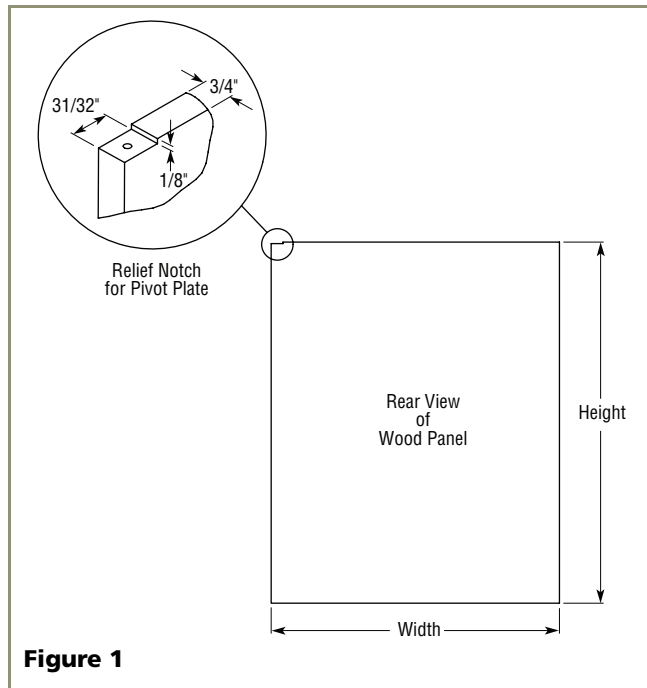
Height: 29-3/4"

2115 & CLR2160 Models:

Width: 14-3/4"

Height: 29-3/4"

The door panel must not weigh more than 20 lbs.

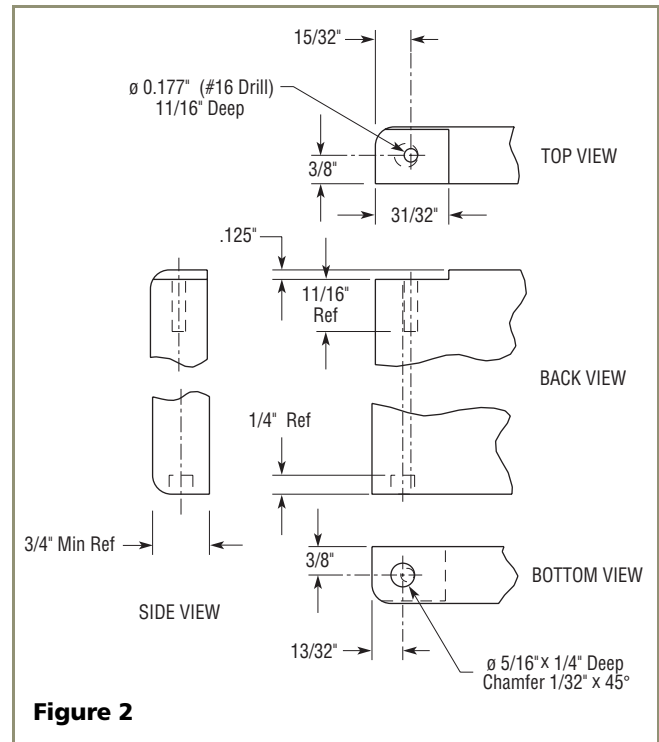


**Figure 1**

### IMPORTANT

Rear View of wood panel for right-hand hinge shown. Use mirror image for left-hand hinges.

2. Create a relief (**Figure 1**) for pivot plate by cutting notch in top corner of overlay panel. Refer to **Figure 2** for exact specifications.



**Figure 2**

Route notch in top corner of overlay panel as shown (see Top and Side Views). Top of notch is entire depth of panel, front to back.

Width: 31/32"

Depth: 1/8"

### CAUTION

Be careful not to drill too deep! Drilling holes too deep may destroy your door panel.

3. Drill hole for upper door hinge (top of panel) (see **Figure 2**, Top View).  
0.177" diameter  
(#16 drill) x 11/16" deep
4. Drill hole for lower door hinge (see **Figure 2**, Bottom View).  
5/16" diameter x 1/4" deep

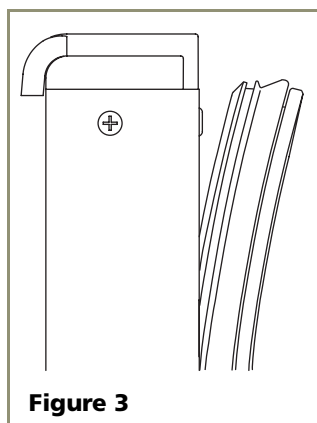
### CAUTION

It is important to ensure that all drilled holes are drilled to the correct depth in order to avoid splits in the wood when hardware is installed.

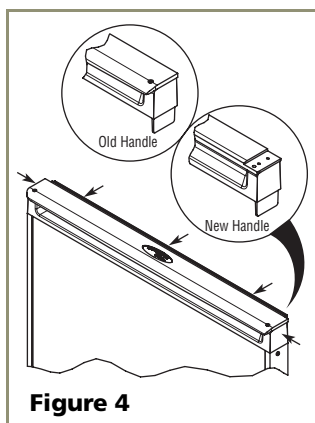
## Installation Instructions

### Removing Existing Door

1. Remove the door shelves by first pulling shelves up at a 45° angle, then straight out.
2. Remove top hinge screw pin (Phillips screwdriver). Remove the door by tilting forward and lifting off the bottom hinge pin.
3. Pull door gasket out of the groove (top edge of door only). Start in the middle and pull outward, moving toward the edge (see **Figure 3**). This may take some force.



**Figure 3**

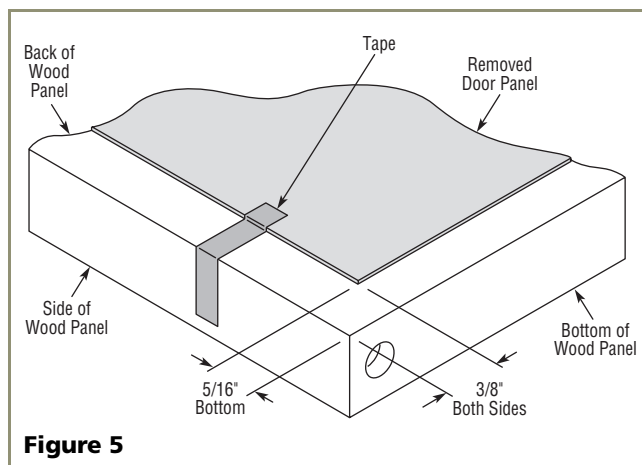


**Figure 4**

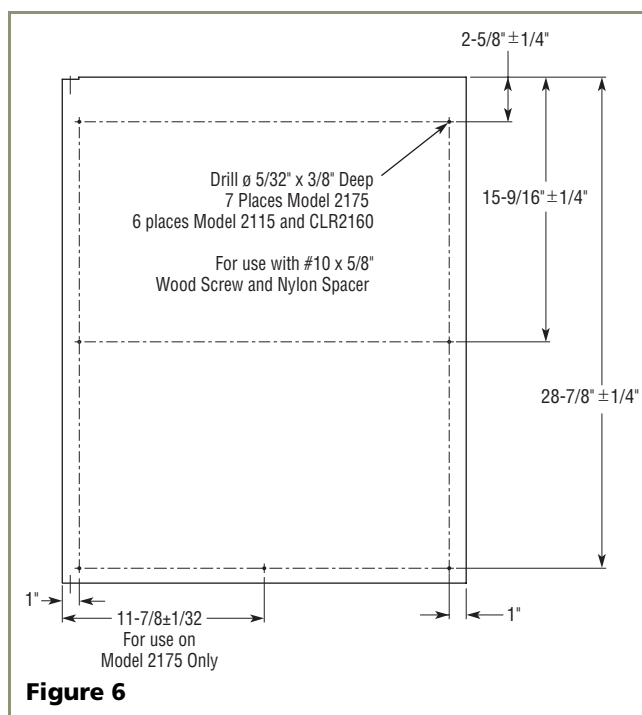
4. Remove the two screws located on both sides of the handle.
5. Remove the handle and discard. (This handle will be replaced with the Overlay Handle included in the Full Overlay Door Panel Kit.)
6. Slide the existing door panel out of the doorframe.

### Attaching the Full Overlay Panel

1. Place and tape the existing door panel on the back of the overlay panel (see **Figure 5**) and drill holes through both panels according to **Figure 6**. Remove tape adjoining the panels and enlarge the six holes in the overlay panel using a 0.201" (#7) drill.
2. If a user-supplied cabinet handle will be used, attach its hardware to the overlay panel at this time.

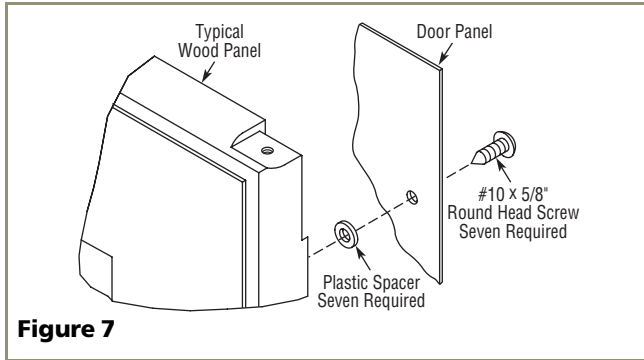


**Figure 5**



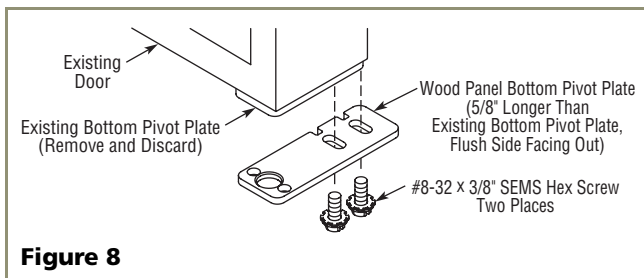
**Figure 6**

3. Attach the door panel to the overlay panel using #10 x 5/8" wood screws and nylon spacers. The nylon spacers fit between the overlay panel and the door panel as shown in **Figure 7**. The spacers allow the original door panel to slide back into the 1/4"-thick door reveal (channel).



**Figure 7**

4. Remove the existing bottom pivot plate and replace with the Full Overlay pivot plate (see **Figure 8**).



**Figure 8**

**IMPORTANT**

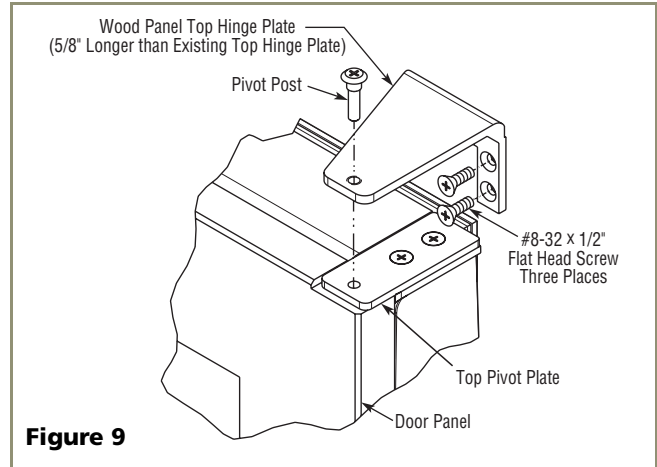
Door panel and overlay panel must be aligned properly or the door will not operate correctly.

**Assembling the Door**

1. Install the assembled panel by sliding the original door panel back into the doorframe.
2. Replace the Overlay Handle and secure with the two screws removed in Step 4 under *Removing Existing Door*.
3. Starting at the corners and working toward the center, push the door gasket back into place.

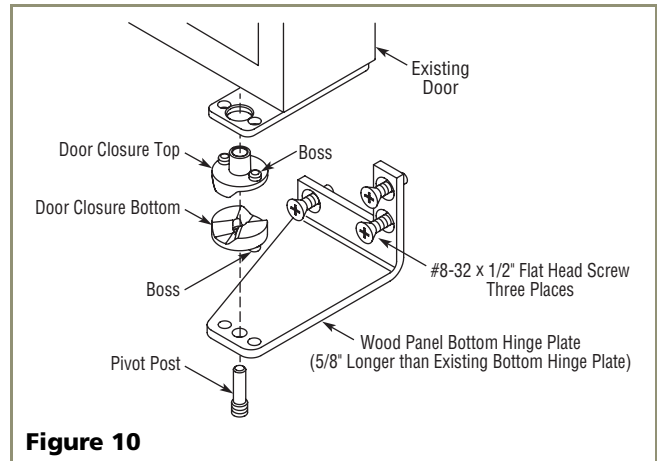
**Installing the Door**

1. Remove the existing hinges from the unit, saving the door closure assembly.
2. Install the new Replacement Top Hinge onto the unit (see **Figure 9**).



**Figure 9**

3. Install the pivot post into the new Replacement Bottom Hinge (using the Phillips screwdriver) and install the hinge onto the unit.
4. Replace the door closure assembly onto the bottom pivot post (see **Figure 10**). Be sure that bosses on closers align with holes in hinge and hinge plate.



**Figure 10**

**IMPORTANT**

Pivot posts must be cleaned. Closers must also be clean and greased to ensure proper operation.

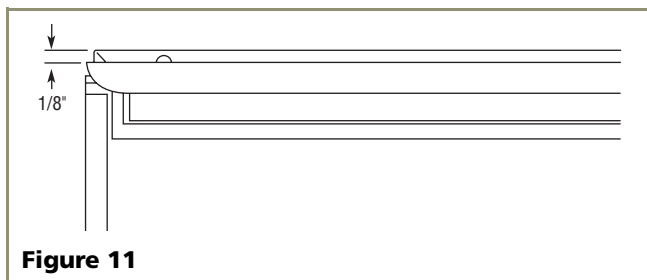
5. Place the modified door onto the pivot post.
6. Position door and install the pivot post into the top hinge (using the Phillips screwdriver).
7. Adjust door as needed for proper closure.
8. Check to see that light goes off when the door closes.
9. Reinstall the door shelves by lining up the bosses and first pushing straight in, then down at a 45° angle.

## Checking Door Alignment

The unit's door is aligned at the factory before shipment. However, its alignment could have been disturbed during shipment or during door panel installation.

### IMPORTANT

Properly aligned, the door should be 1/8" below the top of the unit's cabinet, NOT flush with the top (see **Figure 11**).



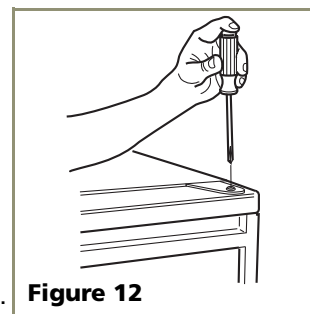
**Figure 11**

1. Compare the top edge of the door to the top edge of the cabinet.
2. If the door edge is 1/8" below and parallel to the top of the cabinet, the door is aligned. If it is not, note whether the side opposite the hinge needs to be moved UP or DOWN, and use the following procedure.

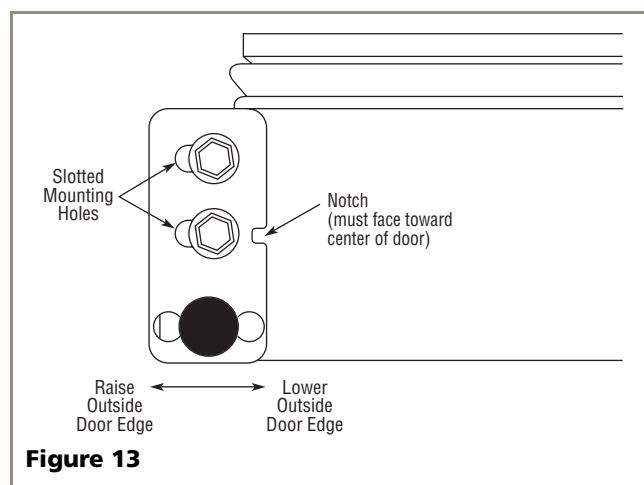
*Note:* If door is adjusted correctly, but panel is not square with the adjacent cabinets, slight adjustments can be made by drilling the holes in the vinyl coated steel panel slightly oversized. See **Figure 6** on **Page 3**.

## Adjusting Door Alignment

1. Remove top hinge screw pin (Phillips screwdriver, see **Figure 12**). Remove door by tilting forward and lifting off bottom hinge pin.
2. With door upside-down, loosen but do not remove the two screws on the door's bottom hinge plate.

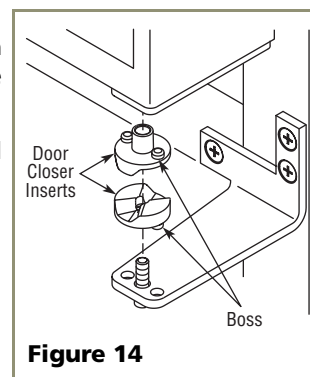


**Figure 12**



**Figure 13**

3. See **Figure 13**. If the top far edge of the door needs to move UP, move the hinge plate toward the outside of the door and retighten screws. If the top far edge of the door needs to move DOWN, move the hinge plate toward the inside of the door and retighten screws.
4. Mount the door to recheck alignment and repeat Steps 2 and 3 if further adjustment is necessary.
5. When top edge of door is parallel to top edge of cabinet, remove the door and ensure the two screws are secure.
6. Remove the door closers from the bottom hinge, clean thoroughly and lubricate the mating surfaces with petroleum jelly.
7. Reinstall the closers, lining up the bosses with holes in hinge and hinge plate (see **Figure 14**).
8. Mount the door and install top hinge pivot pin.



**Figure 14**

## *Echelon Series*

### Who to Call

#### Service Information

If the need for service arises, contact the dealer from whom the unit was purchased. State the Model Number and Serial Number and explain the problem. The Model and Serial Number plate is located inside unit at upper right hand corner.

If you need to locate a service company, you can go online at **[www.U-LineService.com](http://www.U-LineService.com)** and search for a service company by zip code.

**For more than four decades, U-Line has distinguished itself as the leader in built-in undercounter ice making, refrigeration and wine storage appliances.**

*Echelon*<sup>™</sup> SERIES / *Origins* SERIES

U-Line Corporation, located in Milwaukee, WI, is a family operated manufacturer of built-in undercounter icemakers, Combo<sup>®</sup> icemaker/refrigerators, Wine Captain<sup>®</sup> wine storage units, refrigerators, refrigerated drawers and refrigerator/freezers.



*Échelon™ Series*

**Custom 1/4" Door Panel  
Preparation and Installation  
Instructions for  
Models 2175, 2115 and CLR2160**

---

**[www.U-LineService.com](http://www.U-LineService.com)**

**Phone (414) 354-0300 • FAX (414) 354-7905  
Service & Parts Tech Lines Phone (800) 779-2547 • FAX (414) 354-5696  
[OnlineService@U-Line.com](mailto:OnlineService@U-Line.com)**

## Custom 1/4" Door Panel Insert

### Door Panel Preparation

A custom door panel can be inserted into the doorframe. Custom door panels can be flat or raised, as long as the maximum panel thickness where inserted into the door reveal (channel) is 1/4"-thick. For raised panels, the depth of the reveal is 1/4" on all four sides.

#### IMPORTANT

Raised panels will reduce the door's 90° swing/zero clearance if the unit is installed next to a wall or similar type of structure.

For **2175 models** cut the panel insert to the following dimensions.

Custom 1/4" Dimensions:

Width: 23-1/32"  
Height: 27-11/16"

For **2115 & CLR2160 models** cut the panel insert to the following dimensions.

Custom 1/4" Dimensions:

Width: 14-1/32"  
Height: 27-11/16"

The door panel must not weigh more than 20 lbs.

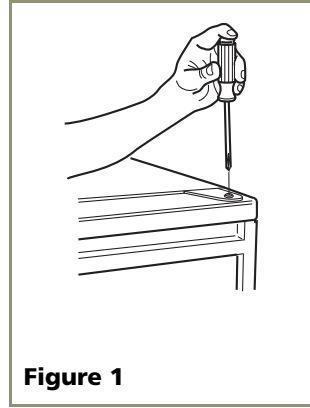
### Door Panel Installation

Install the insert as follows:

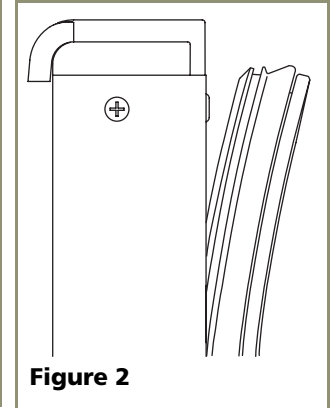
#### CAUTION

Use care when handling the insert. Insert edges may be sharp.

1. Remove top hinge screw pin (using a Phillips screwdriver, see **Figure 1**). Remove door by tilting forward and lifting off bottom hinge pin.

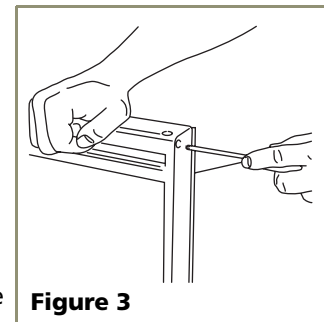


**Figure 1**



**Figure 2**

2. Pull door gasket out of groove (top edge of door only). Start in the middle and pull outward, moving toward the edge (see **Figure 2**). This may take some force.
3. Remove two outside screws holding door handle. Slightly separate door handle from door (see **Figure 3**).
4. Pull handle up and off.
5. Remove and discard existing panel and cardboard spacer.
6. Slide custom door panel insert into 1/4-inch channel in door front.
7. Holding door gasket out of the way, replace handle on door, making sure it is seated properly on insert and that screw holes line up.
8. Install two small screws removed in Step 3.
9. Starting at the corners and working inward, push door gasket into place on door.
10. Place door on bottom hinge pin and install upper hinge screw.



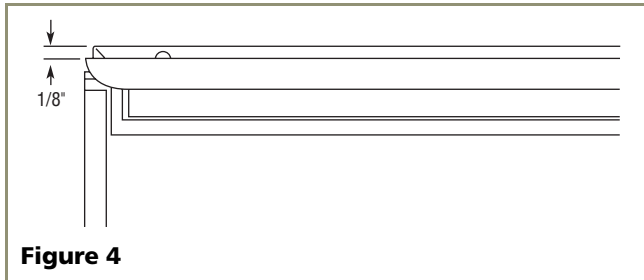
**Figure 3**

## Checking Door Alignment

The unit's door is aligned at the factory before shipment. However, its alignment could have been disturbed during shipment or during door panel installation.

### IMPORTANT

Properly aligned, the door should be 1/8" below the top of the unit's cabinet, NOT flush with the top (see **Figure 4**).

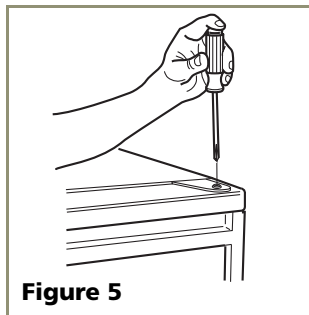


**Figure 4**

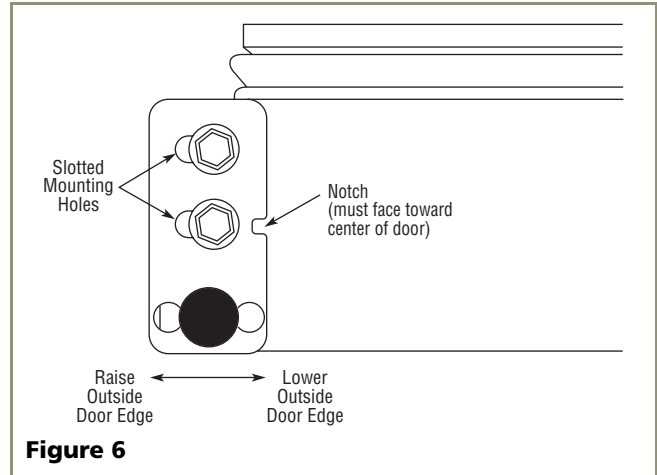
1. Compare the top edge of the door to the top edge of the cabinet.
2. If the door edge is 1/8" below and parallel to the top of the cabinet, the door is aligned. If it is not, note whether the side opposite the hinge needs to be moved UP or DOWN, and use the following procedure.

## Adjusting Door Alignment

1. Remove top hinge screw pin (using a Phillips screwdriver, see **Figure 5**). Remove door by tilting forward and lifting off bottom hinge pin.
2. With door upside-down, loosen but do not remove the two screws on the door's bottom hinge plate.

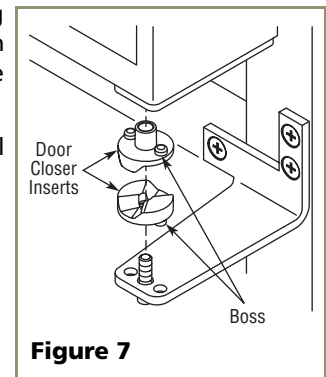


**Figure 5**



**Figure 6**

3. See **Figure 6**. If the top far edge of the door needs to move UP, move the hinge plate toward the outside of the door and retighten screws. If the top far edge of the door needs to move DOWN, move the hinge plate toward the inside of the door and retighten screws.
4. Mount the door to recheck alignment and repeat Steps 2 and 3 if further adjustment is necessary.
5. When top edge of door is parallel to top edge of cabinet, remove the door and ensure the two screws are secure.
6. Remove the door closers from the bottom hinge, clean thoroughly and lubricate the mating surfaces with petroleum jelly.
7. Reinstall the closers, lining up the bosses with holes in hinge and hinge plate (see **Figure 7**).
8. Mount the door and install top hinge pivot pin.



**Figure 7**

## *Échelon™ Series*

---

### Who to Call

#### Service Information

If the need for service arises, contact the dealer from whom the unit was purchased. State the Model Number and Serial Number and explain the problem. The Model and Serial Number plate is located inside unit at upper right hand corner.

If you need to locate a service company, you can go online at **[www.U-LineService.com](http://www.U-LineService.com)** and search for a service company by zip code.

**For more than four decades, U-Line has distinguished itself as the leader in built-in undercounter ice making, refrigeration and wine storage appliances.**

*Échelon™ SERIES / Origin® SERIES*

U-Line Corporation, located in Milwaukee, WI, is a family operated manufacturer of built-in undercounter icemakers, Combo® icemaker/refrigerators, Wine Captain® wine storage units, refrigerators, refrigerated drawers and refrigerator/freezers.