

# CM24P-1, CM24T-1

**dacor**  
The Life of the Kitchen.®

062807

**24" WIDE, COFFEE SYSTEM**

1/2

**PLANNING  
GUIDE**

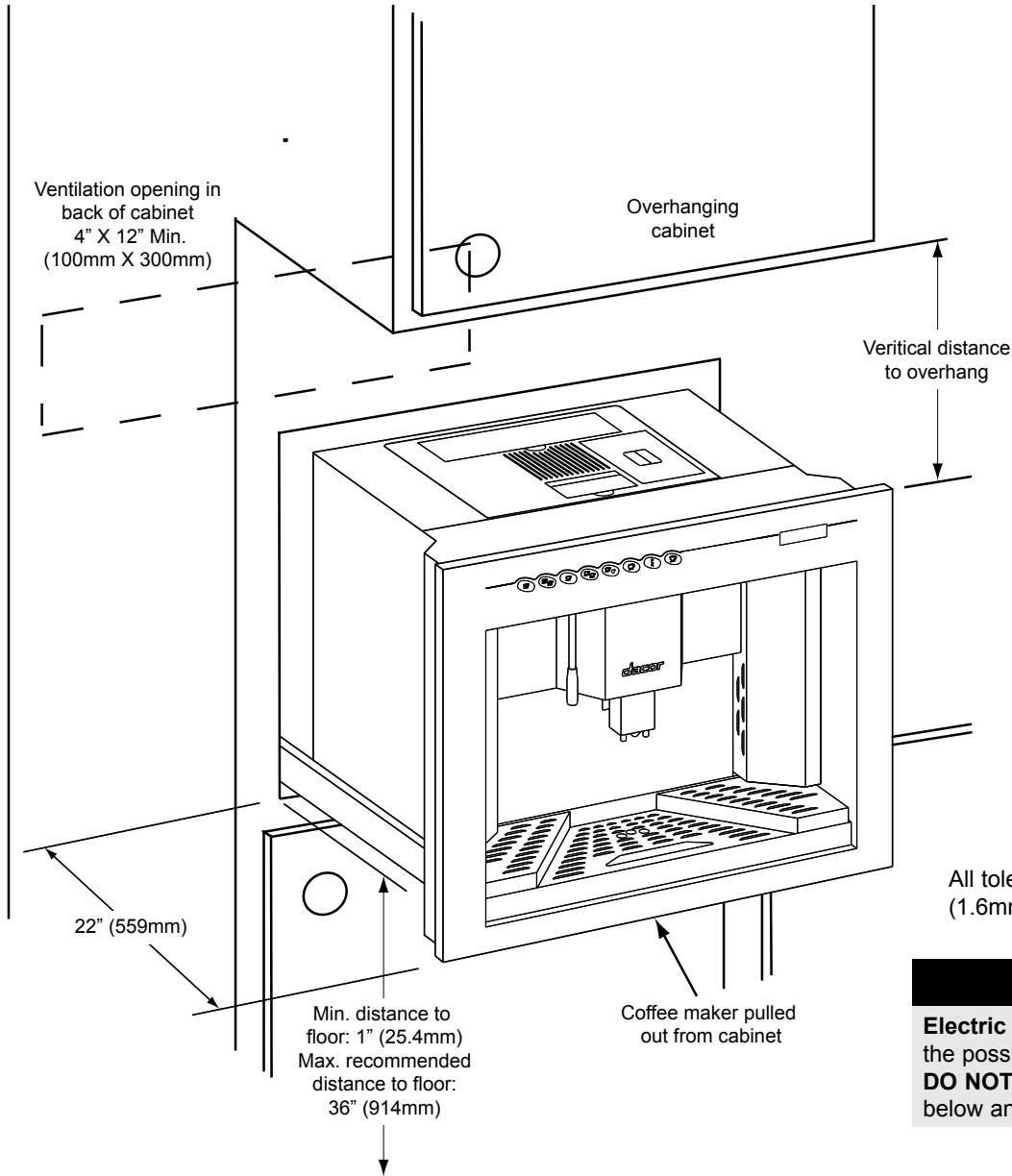

CM24T-1	CM24P-1
14" (356mm) Min.	6" (152mm) Min. 12" (305mm) Recommended

All tolerances: +1/16", -0"  
(1.6mm. -0) unless otherwise stated.

**⚠ WARNING**

**Electric Shock Hazard;** Due to steam and the possibility of spillage during normal use, **DO NOT** install this appliance above or below any other appliance.

**LOCATION SPECIFICATIONS**

Dedicated Circuit Required	Total Connected Load	Approximate Shipping Weight	Fresh Water Capacity
120V, 60Hz, 20A (Breaker)	1.8kW	139 lbs.	1.3 Gal./5 L.

**NOTES:**

1. Electrical box and water shut off should be located in an adjacent cabinet.
2. Electrical cord is located in the lower right rear corner.
3. Water inlet (CM24P-1 only) is located in the lower left rear corner.

4. The coffee system must be installed away from other sources of heat, like other appliances for proper operation.
5. For ventilation purposes, there must be ventilation out of the back of the cabinet. Minimum dimension for ventilation slot in back: 4" X 12" (100mm X 300mm).
6. During normal operation, the user must have access to the top of the unit to fill the coffee bins on top and, on model CM24T-1, be able to remove the water tank. Install the coffee maker low enough so that the user can reach the top of the unit easily when it is slid out of the cabinet.

# CM24P-1, CM24T-1

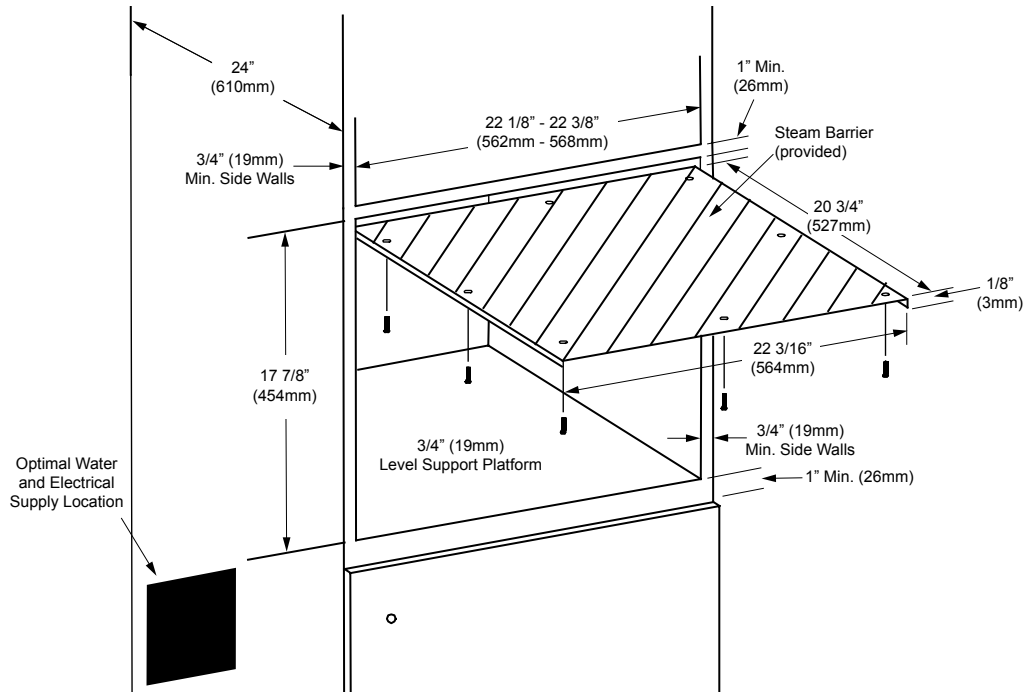

**CUTOUT DIMENSIONS**

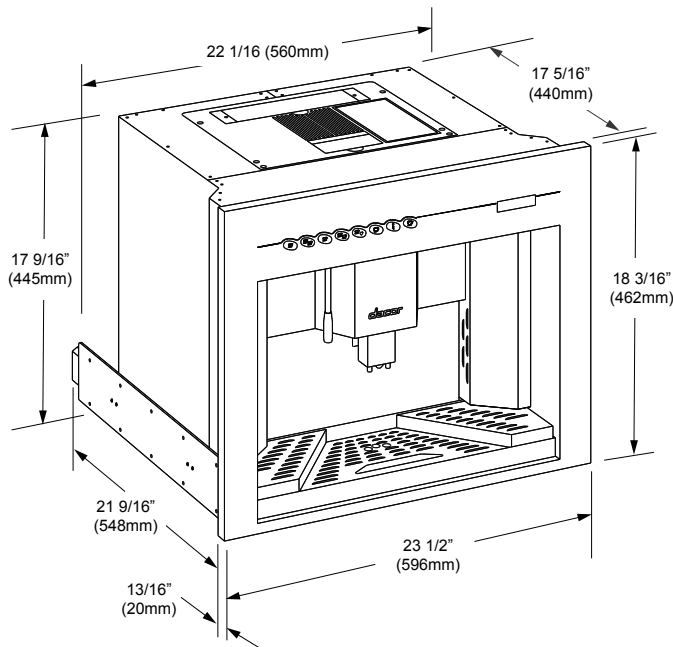

**OVERALL DIMENSIONS**