

CM24P, CM24T

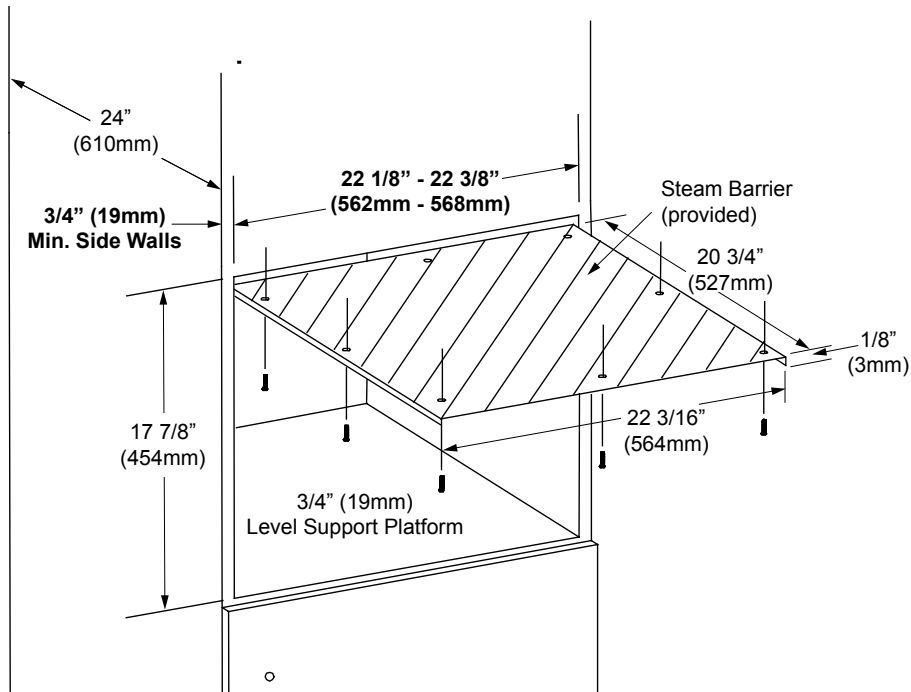

CUTOUT DIMENSIONS

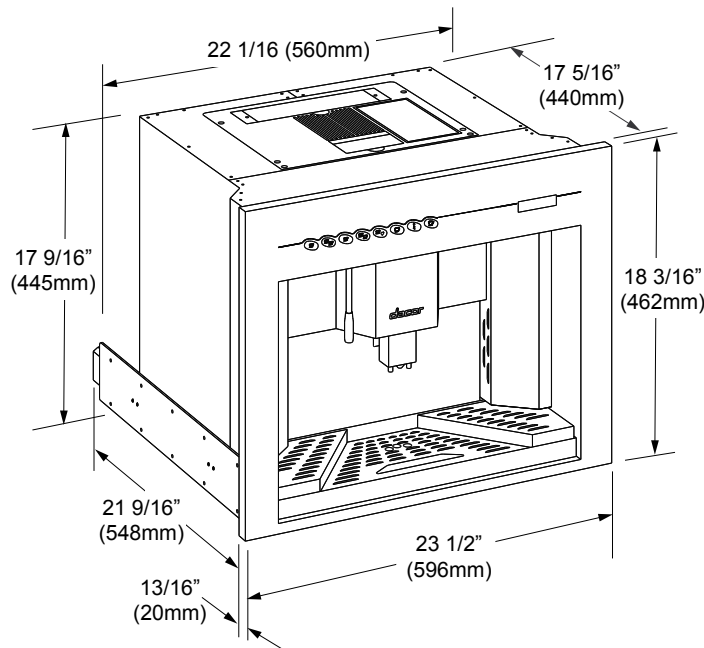

OVERALL DIMENSIONS

Dedicated Circuit Required	Total Connected Load	Approximate Shipping Weight	Fresh Water Capacity
120V, 60Hz, 20A (Breaker)	1.8kW	139 lbs.	1.3 Gal./5 L.



NOTES:

1. Electrical box and water shut off should be located in an adjacent cabinet.
2. Electrical cord is located in the lower right rear corner.
2. Water inlet (CM24P only) is located in the lower left rear corner.