



**U-LINE**  
CORPORATION

# CLEAR ICE MAKER/REFRIGERATOR MODEL CLRC02175

Capacity: 2.5 cubic feet of refrigeration; 40 lbs daily ice production;  
15 lbs ice storage

Defrost Type: Automatic Defrost  
Colors: Stainless Steel, Black, White

*Echelon Series*

## Features & Benefits



Feature	Benefit
High daily ice production and storage	Produces up to 40 lbs of ice per day and stores up to 15 lbs
Clear ice production capability plus refrigeration all in one unit	Both clear ice making capability and refrigeration all in one 24" wide footprint
Electronic control module	Automatically adjusts for changes in room and water temperatures to maximize ice production and provide consistently sized ice cubes
Touch Control Digital Technology	<ul style="list-style-type: none"> <li>Provides ability to set and see the temperature in the refrigerator</li> <li>Enables the user to:               <ul style="list-style-type: none"> <li>- initiate the Automatic Self-Cleaning process</li> <li>- adjust the size of the ice cube</li> <li>- turn off the ice maker while maintaining the refrigerator's functions</li> <li>- turn entire unit on/off</li> </ul> </li> </ul>
Easy, self-cleaning process	<ul style="list-style-type: none"> <li>Simple and easy to use. Within one hour, the internal ice making components are thoroughly cleaned and rinsed.</li> <li>Ensures high quality ice, plus helps to maintain proper operation</li> </ul>
Optional 3/4" full overlay door panel	<ul style="list-style-type: none"> <li>Provides a fully integrated appearance with surrounding décor while maintaining zero clearance</li> <li>Easy to install. Black and white models only</li> <li>Must order kit number U-OL2175</li> </ul>
Standard door will accept a 1/4" panel	<ul style="list-style-type: none"> <li>Ability to match surrounding décor and cabinets</li> <li>Black and white models only</li> </ul>
Flexible water drain options	Water may be drained using either a gravity feed drain or a U-Line supplied P60 drain pump. See back page for more information.
Built-in or freestanding	<ul style="list-style-type: none"> <li>Provides custom look</li> <li>No additional clearance around sides, top or rear of unit for ventilation. <b>Do not obstruct front grille.</b></li> </ul>
Stainless steel model	<ul style="list-style-type: none"> <li>Offers a full wrap stainless door and cabinet, along with a curved, sculpted stainless door handle and a stainless-like grille</li> <li>Must be ordered right- or left-hand hinged</li> <li>Optional bold commercial-style stainless handle available for purchase</li> </ul>
Three fully encapsulated curved glass shelves	<ul style="list-style-type: none"> <li>Contains spills while providing an upscale appearance</li> <li>Easy to clean</li> </ul>
Two contoured, adjustable in-door storage shelves	Provide easy access, flexible storage
Crisper drawer	Optimizes product storage
Self-closing door	<ul style="list-style-type: none"> <li>Engages when the door is open 8-10"</li> <li>Ensures a positive door seal and prevents door bounce-back</li> </ul>
Field-reversible doors	<ul style="list-style-type: none"> <li>Flexible installation options</li> <li>Black and white models only</li> </ul>
Integrated handle	<ul style="list-style-type: none"> <li>Sleek designer look that does not add depth to the cabinet</li> <li>Black and white models only</li> </ul>
Vinyl-clad cabinets	<ul style="list-style-type: none"> <li>Textured, rich look. More resistant to scratching, peeling and flaking</li> <li>Cabinet extends to the floor</li> <li>Black and white models only</li> </ul>
Recessed interior light	Located in the refrigerator. Automatically illuminates when the door is opened.
Leveling legs	More precise undercounter fit - durable - factory installed
Sabbath or "Black Out" mode	<ul style="list-style-type: none"> <li>Easily turns off all lights and control displays</li> <li>Automatically resets after 36 hours</li> </ul>
Contemporary grille design	Integrates seamlessly with surrounding cabinets

# Dimensions & Specifications

*Echelon Series*

**CLRCO2175**

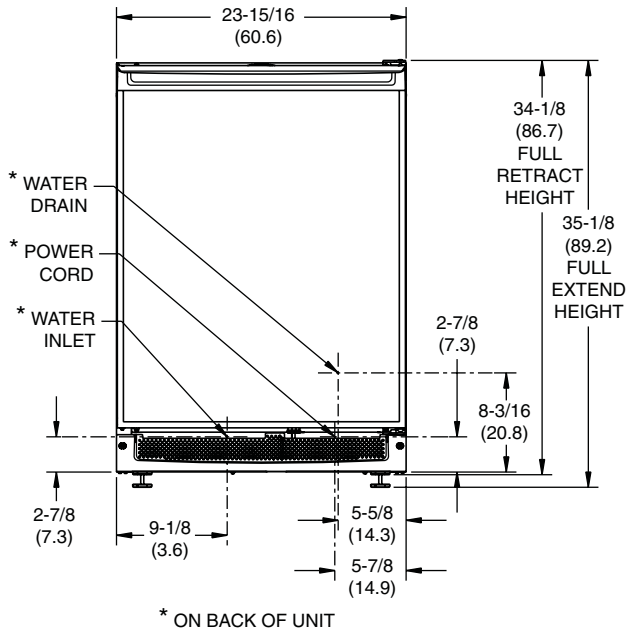

**CLRCO2175 (Stainless Steel)**

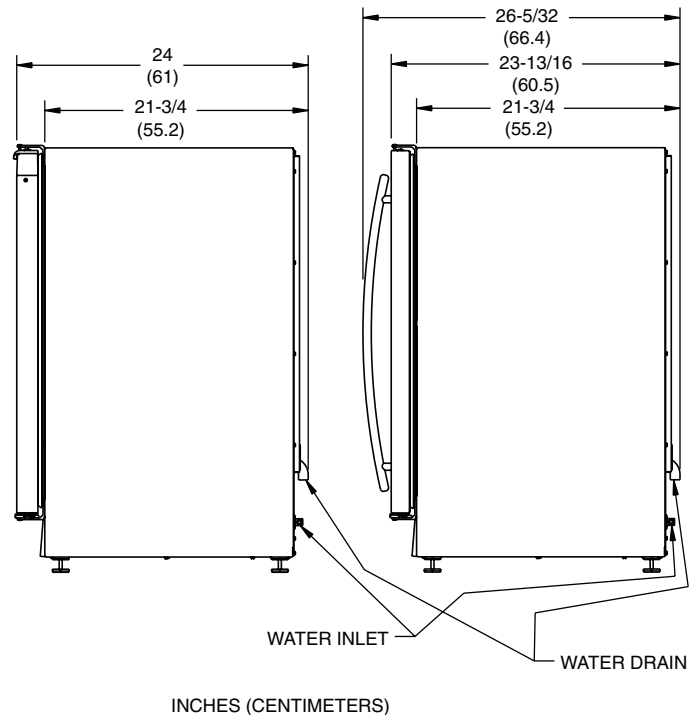

## Clear Ice Maker/Refrigerator Model CLRCO2175

### Specifications

Shipping Weight:	
Black and White Models	141 lbs (64 kg)
Stainless Steel Models	144 lbs (65 kg)
(1) Running Amps	4.0
(1) Maximum Start-up Amps	26.5

### Capacities

Refrigerator volume	2.5 cubic feet
Freezer volume	N/A
Approximate daily ice production	Up to 40 lbs
Ice storage	Up to 15 lbs

(1) Amps pertain to a 110/115 volt, 60 Hz electrical environment.

Stainless steel models must be ordered right- or left-hand hinged.

Stainless steel models: Allow 2-1/2" clearance on hinge side for 90° door opening when installed against a wall.

Water drain options:

Depending on the model, the CLRCO2175 may either be installed using a gravity feed drain or may come equipped with a P60 drain pump. The P60 drain pump can also be installed in the field.

- Gravity Drain:
- A 7" height from the back of the unit
  - Must have a 1/4" drop per foot of drain line
  - NO upward slopes of the drain line should occur with a gravity drain model.

- P60 Drain Pump:
- Fully sealed and required if pumping water UPWARD or if draining water a long distance.

*Please visit [www.U-Line.com](http://www.U-Line.com) for Installation Guide.  
All specifications subject to change without notice.*



8900 North 55th Street • Milwaukee, Wisconsin 53223  
Phone: 414-354-0300 • Fax: 414-354-7905 • [www.u-line.com](http://www.u-line.com)