

CL2R248

34.0" x 23.63" x 23.63" (H x W x D)

Built-in undercounter two-drawer all-refrigerator in complete stainless steel with panel-ready drawer fronts

Highlights:

Create the perfect look with panel-ready drawer fronts that can accept custom overlay panels

Flexible design allows built-in or freestanding use in 24" wide spaces

Complete stainless steel construction for luxury built to last

Digital controls offer easy and intuitive temperature management



AjMadison
Your Appliance Authority
800-570-3355

Built-in capable	Front-breathing design lets you make the best use of space by installing your appliance under the counter
Stainless steel exterior	Complete stainless steel construction ensures lasting durability and style
Two stainless steel drawers	Slide-out drawers offer 3.4 cu.ft. of interior storage
Panel-ready drawer fronts	Drawers accept overlay panels (size: 25.15" x 14.92" at 3/4" thick) to let you seamlessly blend the refrigerator into cabinetry design
Digital thermostat	Electronic controls ensure easy temperature management, with an external readout in Celsius or Fahrenheit
Automatic defrost	Reduced maintenance with auto defrost system
Stainless steel kickplate	Completes the professional look down to the toe kick
Open drawer alarm	Audible alarm will sound if the drawers are left ajar for over a minute
Temperature alarm	High temperature alarm sounds if the unit's interior goes out of the recommended range
LED lighting	Elegant and efficient lighting offers a gentle illumination for the drawer interiors

CL2R248 Specifications:

Height	34.0"
Width	23.63"
Depth	23.63"
Capacity	3.4 cu.ft.
Ext Depth with Handle	25.0"
Interior Height 1	9.25"
Interior Width 1	17.25"
Interior Depth 1	15.5"
Interior Height 2	10.0"
Interior Width 2	17.25"
Interior Depth 2	15.5"
Comp Step Height	3.5"
Comp Step Width	17.25"
Comp Step Depth	4.0"
Shipping Weight	130.0 lbs.
Weight	106.0 lbs.
Voltage/Frequency	115 V AC/60 Hz
Amps	0.8
Canadian Electrical Safety	ETL-C
US Electrical Safety	ETL
Energy Usage/Year	275.0 kWh/year
Drawers	true
Drawer Quantity	2
Defrost Type	Automatic
Depth with door at 90°	39.38"
Fan Type	Interior and Exterior
Thermostat Type	Digital
Light	true
Level Legs Quantity	2
High Side PSI	270.0
Low Side PSI	105.0
Refrigerant Type	R600a
Freon Oz	0.99
Parts/Labor Warranty	1 Year
Compressor Warranty	5 Years

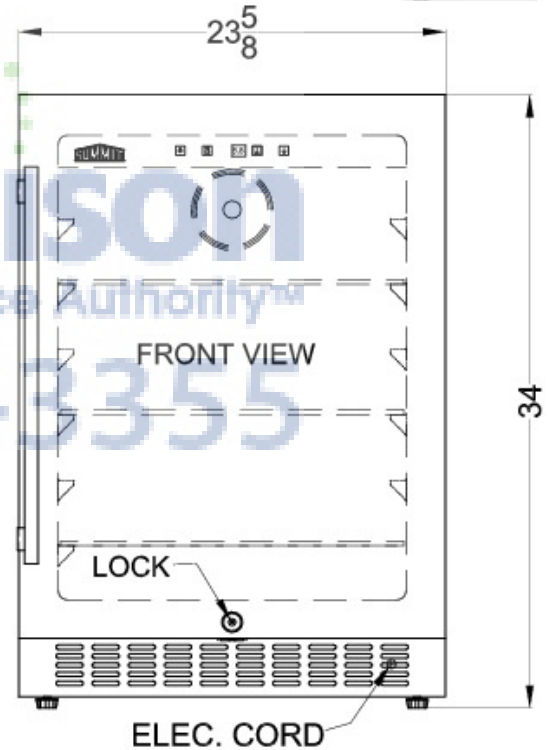
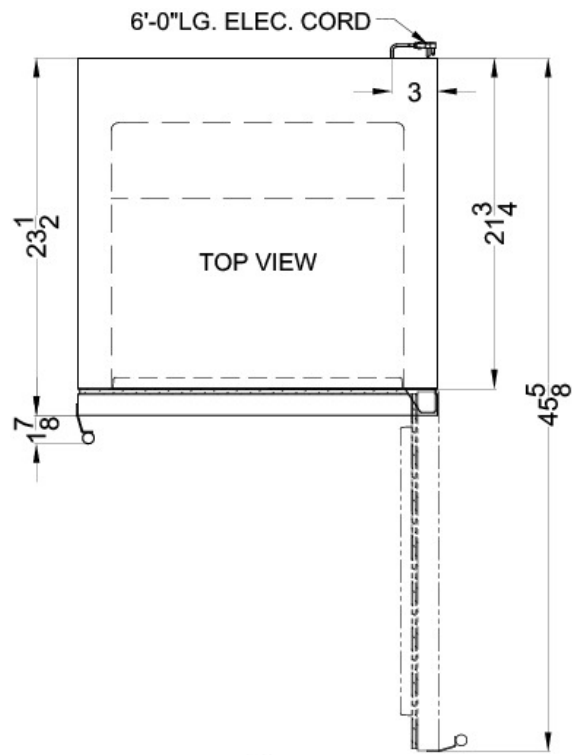

AjMadison
Your Appliance Authority™
800-570-8355

Summit Appliance Division, Felix Storch, Inc.
770 Garrison Ave • Bronx, NY 10474
Phone: 718-893-3900 • Fax: 718-842-3093
Email: info@summitappliance.com