

# NON-METERED COMMERCIAL WASHER



## Featuring Mechanical Controls



2013 Department of Energy Compliant  
Modified Energy Factor: 1.85

Water Factor: 6.85

On average, uses 20 gallons per cycle—the  
lowest water consumption for Whirlpool®  
Commercial top-load washers.

### FOR YOUR CUSTOMERS

- Large Capacity Wash Basket is Ideal for Family-Size Loads
- Proven Cleaning Performance
- Extra-Large Lid and Tub Opening
- 5 Cycle Options: Heavy Duty, Normal, Delicates, Drain & Spin, Rinse & Spin
- Separate Temperature Controls
- Ergonomic Control Knobs
- Gentle Agitation

### AUTOMATIC LOAD SENSING

Adjusts water fill level based on load size, reducing water usage by up to 18 gallons per wash cycle.

### BALANCE RING ADAPTER—CLOTHES GUARD

Discourages overloading and keeps small items out of the pump.

### SECURE LID SYSTEM WITH SAFE RELEASE

To help ensure safe operation, the lid locks at start of cycle. Prevents damage when forced open.



### INDUSTRIAL STRENGTH WATER INLET HOSES

- Tested to 1100 PSI
- Extra-Long 6' Hoses

## CAE2793BQ—27" Non-Metered Commercial Washer

- 2.9-Cu.-Ft. Wash Basket
- Low Water Factor
- 5 Cycles: Heavy Duty, Normal, Delicates, Drain & Spin, Rinse & Spin
- Cycle Indicator LEDs
- Powdered Paint Top and Lid, Rustproof Stainless Steel Torx® Control Panel Screws
- Galvanized, Heavy-Gauge Cabinet Back, Side and Front Panel
- High-Speed Spin—700 RPM (maximum)
- 1/3 HP Motor
- **90-Day Labor/2-Year Limited Parts Only Warranty\***

\*Call 1-800-662-3587 for warranty details.

# NON-METERED COMMERCIAL WASHER



## Featuring Mechanical Controls

### Whirlpool® Non-Metered Commercial Washer Mechanical Controls

WASHER SPECIFICATIONS	
<b>MODEL</b>	CAE2793BQ
<b>GENERAL INFORMATION</b>	
Modern design and look with all metal console and ergonomic control knobs. Automatic lid lock feature.	Large Capacity 2.9-Cu.-Ft. Basket
<b>BASKET VOLUME</b>	2.9 Cu. Ft.
<b>MOTOR</b>	
120 Volt, 1/3 HP, 1/4 kw, with thermal overload protection	Single-speed, permanent split capacitor, reversible motor
Spin RPM—Maximum	700
<b>MAXIMUM RATED CURRENT—AMPS (VOLT)</b>	8 (120)
<b>ELECTRICAL REQUIREMENTS</b>	120V, 60 Hz
<b>SHIPPING WEIGHT (EST.)</b>	137 Lbs. Crated, 122 Lbs. Uncrated
<b>DIMENSIONS</b>	
Cabinet Width—in. (mm)	27 (686)
Cabinet Depth—in. (mm)	25.5 (648)
Cabinet Height—in. (mm)	40.8 (1036)

Dimensions are for planning purposes only. For complete information, see installation instructions packed with product.

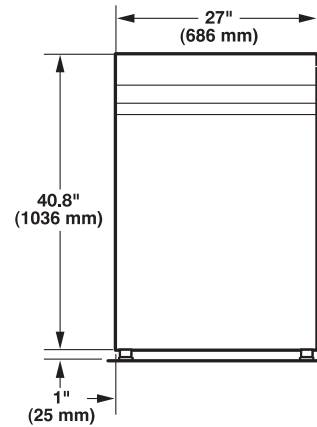

WASHER FRONT VIEW

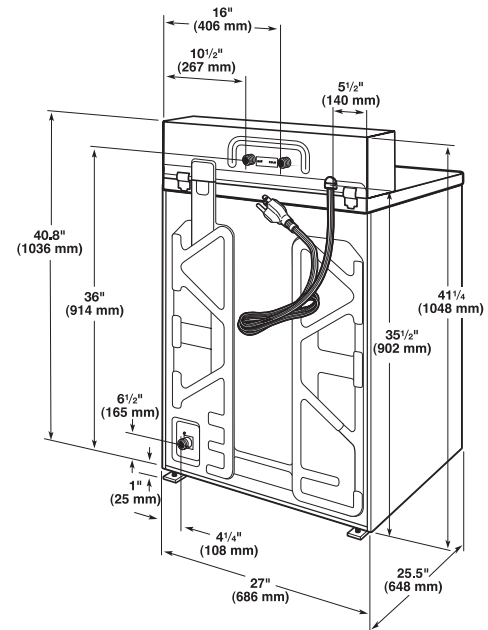

WASHER BACK VIEW



To Locate a Distributor Near You, Please Visit [www.whirlpoolcommerciallaundry.com/distributor](http://www.whirlpoolcommerciallaundry.com/distributor), or call 1-800-662-3587.