



C30GGXU

Classic

Free-Standing Gas Range, 30"

AISI 304 Stainless steel

Oven door in Stopsol® glass and stainless steel

Ergonomic control knobs

DIMENSION

(w X d X h): 30" X 25" X from 35 5/8" to 37 6/8"

GAS OVEN

3 Cooking modes (gas, gas with fan, broil)

Fan option for static gas

Gross Oven Capacity: 3,55 Cu. Ft.

Usable (net) Oven Capacity: 3,2 Cu. Ft.

"Ever-clean" enamelled oven interior

Timer with alarm (60min)

Adjustable thermostat 300° - 530°F

Air cooled triple glazed removable door

Bake element power 16500 BTU

Broiler power 12500 BTU

GAS RANGETOP

Heavy duty cast iron grates and matt black burner caps

Sealed burners

Electronic automatic ignition incorporated in the knobs

LP Gas conversion kit included

3 15/16" Polished stainless steel backsplash

Deep range-top base to contain spillage

5 Gas burners:

4 Burners Min-Max with Simmer feature

Central High Output: inner 1100 BT; inner + outer 17.000 BTU burner

Front right: simmer 1650; BTU10,100 BTU burner

Back right: simmer 1650; BTU10,100 BTU burner

Back left: simmer 1650; BTU10,100 BTU burner

Front left: simmer 1650; BTU10,100 BTU burner

SAFETY

Automatic reignition when flame is accidentally extinguished

Valved gas oven

Ventilated door with cooling system to prevent overheating

Anti-tilting norms satisfied

Suitable for building-in

ELECTRIC CONNECTION

Connected load (nominal power): 1.2 Amp

Voltage 120V 1N ~; Frequency 60Hz.

ACCESSORIES INCLUDED

1 Baking tray, 1 Broil pan, 1 Broiler rack, 1 Wire rack, 1 Wok ring

OPTIONAL ACCESSORIES

Island trim, Side trim, Backsplash, 30" hood

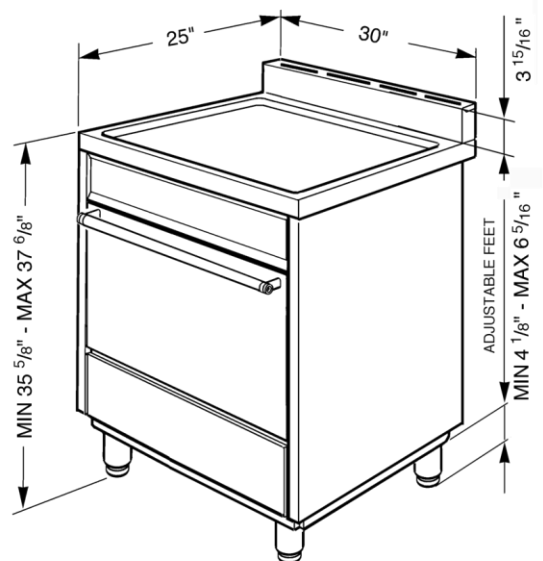

Product available from June 1st, 2011

FUNCTIONS



Bottom heat:

This function is ideal for foods that require extra base temperature without browning, e.g. pastry dishes, pizza. Also suitable for slow cooking of stews and casseroles.



Convection with bottom heat:

This combination quickly completes the cooking of foods that are ready on the surface, but require more cooking inside, without further browning. Suitable for any type of food.



Intensive broil:

This allows rapid cooking and browning of foods. Best results can be obtained from using the top rack for small items, the lower racks for larger items, such as chops or sausages. Cooking using this method should be carried out with the door closed, unless instructed to do otherwise.



Convection broil:

Please note: cooking in this mode is conducted with the door closed. The fan reduces the fierce heat from the broiler, providing an excellent method for broiling a range of foods; chops, steaks, sausages etc without having to turn the food during cooking. This gives good results, reduces drying out of foods and gives even browning and heat distribution, the top two racks being recommended for use. The lower area of the cavity can also be used to keep other items warm at the same time.



Defrost:

The circulation of air at room temperature enables quicker thawing of frozen food, (without the use of any heat). Ideal for use prior to cooking of readymade dishes, or cream filled products etc.