



## BUILT-IN OUTDOOR GAS GRILLS 24, 30, & 36 "T" Series

### INSTALLATION INSTRUCTIONS AND OWNER'S MANUAL

**INSTALLER:** Leave these instructions with consumer.  
**CONSUMER:** Retain for future reference.



**IMPORTANT:** READ THESE INSTRUCTIONS CAREFULLY BEFORE STARTING INSTALLATION OR USE.

### WARNINGS AND SAFETY CODES

#### **⚠ DANGER:**

##### **IF YOU SMELL GAS:**

1. Shut off the gas to the appliance.
2. Extinguish any open flame.
3. Open lid.
4. If odor continues, keep away from the appliance and **immediately** call your gas supplier or the fire department.

**CODE AND SUPPLY REQUIREMENTS:** This grill must be installed in accordance with local codes and ordinances, or, in the absence of local codes, with the latest National Fuel Gas Code (ANSI Z223.1/NFPA 54), or Natural Gas and Propane Storage and Handling Installation Code (CSA-B149.1).

This appliance and its dedicated manual shutoff valve must be disconnected from the gas-supply piping system when testing the system at pressures in excess of ½ psig (3.5 kPa).

This appliance must be isolated from the gas-supply piping system by closing its dedicated manual shutoff valve during any pressure testing of the gas-supply system at pressures up to and including ½ psig (3.5 kPa).

**Proper operation of your grill requires prompt and periodic maintenance. See the CARE & CLEANING section for details.**

#### **⚠ WARNING:**

1. Do not store or use gasoline or other flammable vapors and liquids in the vicinity of this or any other appliance.
2. An LP cylinder not connected for use shall not be stored in the vicinity of this or any other appliance.

#### **⚠ WARNING:**

Improper installation, adjustment, alteration, service, or maintenance can cause injury or property damage. For proper installation, refer to the installation instructions. For assistance or additional information, consult a qualified professional installer, service agency, or the gas supplier.

All electrical outlets in the vicinity of the grill must be properly grounded in accordance with local codes, or, in the absence of local codes, with the *National Electrical Code, ANSI/NFPA 70*, or the *Canadian Electrical Code, CSA C22.1*, whichever is applicable.

Keep all electrical-supply cords and fuel-supply hoses away from any heated surface.



Certified to: ANSI Z21.58b-2012  
CSA 1.6b-2012

## GRIL EXTÉRIEUR DE GAZ DU BUILT-IN

**IMPORTANT:** LISEZ CES INSTRUCTIONS SOIGNEUSEMENT AVANT DE COMMENCER L'INSTALLATION OU L'UTILISATION

### SÛRETÉ ET CODES D'AVERTISSEMENT

#### **⚠ DANGER:**

##### **SI VOUS SENTEZ LE GAZ :**

1. Coupez le gaz à l'appareil.
2. Éteignez-vous n'importe quelle flamme nue.
3. Ouvrez le couvercle.
4. Si l'odeur continue, gardez loin de l'appareil et appelez immédiatement votre département de fournisseur ou de feu de gaz.

#### **CONDITIONS DE CODE ET D'APPROVISIONNEMENT:**

Ce gril doit être installé selon des codes et des ordonnances locaux, ou, en l'absence des codes locaux, avec l'un ou l'autre le plus défunt *Code national de gaz de carburant* (norme ANSI Z223.1/NFPA 54), et *Stockage de gaz naturel et de propane et manipulation du code d'installation* (CSA-B149.1).

Cet appareil et ses différents robinets d'isolement doivent être démontés du gaz-fournissent le système sifflant en examinant le système aux pressions au-dessus du ½ psig (kPa 3.5).

Cet appareil doit être isolé dans gaz-fournissent le système sifflant par fermeture que ses différents robinets d'isolement manuels pendant tous les essais sous pression du gaz-fournissent le système aux pressions jusques et y compris le ½ psig (kPa 3.5).

- Ce gril est pour utilisation à l'extérieur seulement. Si l'appareil est entreposé à l'intérieur, enlever les bouteilles et les laisser à l'extérieur.
- Ne pas ranger le gril immédiatement après l'avoir utilisé. le laisser refroidir avant de le déplacer ou de la ranger. Le non respect de cette mesure de sécurité pourrait entraîner un incendie causant des dommages à la propriété, des blessures ou la mort.
- Ne pas utiliser cet appareil sous une surface combustible.
- Ne pas utiliser cet appareil sous un auvent. Le non respect de cette mesure de sécurité pourrait entraîner un incendie ou des blessures.
- Dégagement minimal entre les parois latérales et l'arrière de l'appareil et la construction combustible (45.7 cm à partir des parois latérales et 45.7cm à partir de l'arrière).
- Le régulateur de pression de gaz prévu avec cet appareil de cuisson à gaz pour l'extérieur doit être utilisé. Ce régulateur est réglé pour une pression de sortie de 5 pouces de colonne de l'eau pour le gaz naturel, et 10 pouces pour le propane.
- LE RÉGULATEUR INCLUS D'APPAREILS EST ÉVALUÉ POUR LE MAXIMUM DE 1/2 (LIVRES PAR POUCE CARRÉ). SI VOTRE OFFRE DE GAZ EST 1/2 PLUS GRAND QUE (LIVRES PAR POUCE CARRÉ), UN RÉGULATEUR ADDITIONNEL DOIT ÊTRE INSTALLÉ AVANT LE GRIL. VOIR LA SECTION DE CONDITIONS

#### **⚠ AVERTISSEMENT:**

1. Ne stockez pas ou n'employez pas l'essence ou d'autres vapeurs et liquides inflammables à proximité de ceci ou d'aucun autre appareil.
2. Un cylindre de propane non relié pour l'usage ne sera pas stocké à proximité de ceci ou d'aucun autre appareil.

#### **⚠ AVERTISSEMENT:**

L'installation inexacte, l'ajustement, le changement, le service, ou l'entretien peuvent causer des dommages ou des dégâts matériels. Référez-vous à ce manuel. Pour l'aide ou l'information additionnelle, consultez un installateur professionnel qualifié, l'agence de service, ou le fournisseur de gaz.

Toutes les sorties électriques à proximité du gril doivent être correctement fondues selon des codes locaux, ou en l'absence de local code, avec le code électrique national, ANSI/NFPA 70, ou le code électrique canadien, CSA C22.1, celui qui est applicable.

Maintenez tout électrique-fournissent des cordes et carburant-fournissent des tuyaux partis de n'importe quelle surface de chauffage.

#### **D'OFFRE DE GAZ POUR LA PRESSON APPROPRIÉE D'OFFRE DE GAZ.**

- Ne couvrez jamais la surface entière de cuisine ou de gril de gauffreuses ou de casseroles. La surchauffe se produira et les brûleurs ne seront pas très performants quand la chaleur de combustion est emprisonnée au-dessous de la surface à cuire.
- Ne pulvérisez jamais l'eau sur une unité chaude de gaz, comme ceci peut endommager des composants de porcelaine ou de fer de fonte.
- Une fuite de GPL peut causer un incendie ou une explosion si enflammée entraînant des blessures corporelles graves ou la mort.
- Communiquez avec le fournisseur de GPL pour les réparations ou pour disposer de qules bouteille ou du GPL non utilisé.

**Certifié à la norme: ANSI Z21.58b-2012 / CSA 1.6b-2012**

**INSTALLATEUR :** Laissez ces instructions avec le consommateur.  
**CONSOMMATEUR :** Maintenez pour la future référence.

# TABLE OF CONTENTS

1	WARNINGS AND SAFETY CODES
4	PARTS LIST
7	MODEL SPECIFICATIONS
7	COUNTERTOP OVERHANG
8	SUBSTRATE
8	BUILT-IN GRILL DIMENSIONS TABLE
9	GRILL MAINTENANCE AND SAFETY INFORMATION
10	INSTALLATION REQUIREMENTS
11	ENSURE PROPER COMBUSTION AIR AND COOLING AIRFLOW
11	EXHAUST REMOVAL
11	GAS-SUPPLY PLUMBING REQUIREMENTS
12	ENCLOSURE REQUIREMENTS
12	NATURAL GAS INSTALLS
12	PROPANE GAS INSTALLS (HOUSEHOLD & CYLINDER)
12	WHEN A PROPANE CYLINDER IS USED
13	INSTALLATION
13	COUNTER PREPARATION
13	CONNECT THE GAS SUPPLY
15	SAFE USE & MAINTENANCE OF PROPANE GAS CYLINDERS
17	IDENTIFICATION OF GRILL CONTROLS
19	LIGHTING (IGNITION) INSTRUCTIONS
19	SHUTTING OFF THE UNIT
20	ROTISSERIE INSTRUCTIONS (IF EQUIPPED)
21	ACCESSORIES
21	THE VAPORIZER PANEL(S)
22	DRIP TRAY
23	CARE & CLEANING
24	CHECKING AND CONVERTING GAS TYPE
28	CONTROL PANEL REMOVAL
29	VALVE "LOW" SETTING ADJUSTMENT
30	NOTES PAGE
31	TROUBLESHOOTING
32	WARRANTY

# PARTS LIST

## **IMPORTANT**

This AOG oven and backburner (if equipped) are fully pre-assembled and tested at the factory.

**DO NOT attempt to remove the oven and backburner from the barbecue prior to or during installation or damage to the connecting gas line and ignitor wiring may occur.**

The plastic straps that secure the oven to the barbecue unit must be removed and discarded prior to lighting the barbecue.

This note applies for all 3 size (24", 30", 36") models.

24" Model shown

Replacement parts can be ordered from your local AOG dealer.

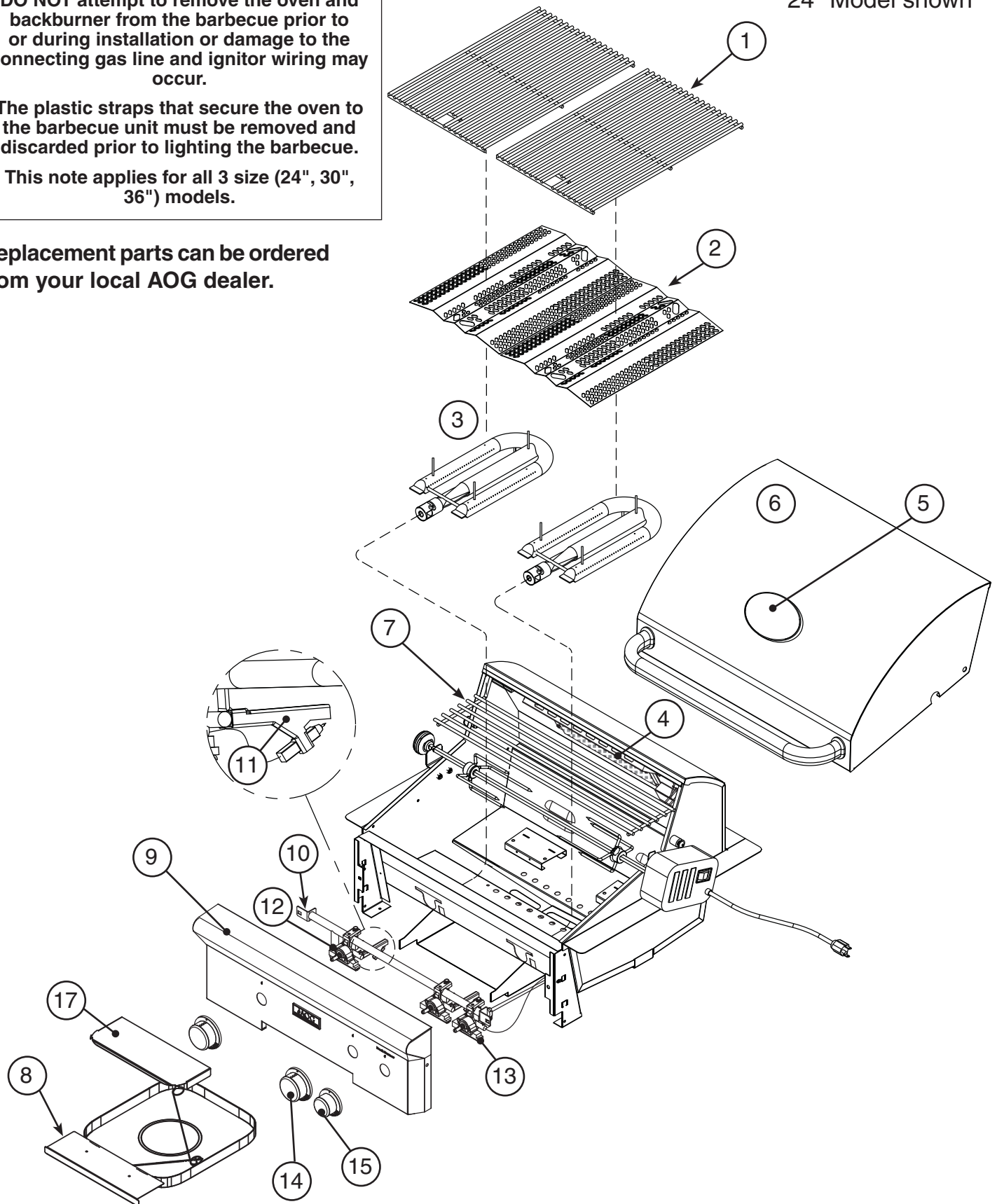

## PARTS LIST (Cont.)

Item	Description	24"		30"		36"	
		Part No.	Qty.	Part No.	Qty.	Part No.	Qty.
1.	Stainless cooking grid (set of 2 or 3)	24-B-11	1	30-B-11	1	36-B-11	1
2.	Vaporizer panel	24-B-05	2	30-B-05	3	36-B-05	3
3.	Main burner	24-B-06	2	24-B-06	3	24-B-06	3
4.	Backburner*	24-B-17T	1	24-B-17T	1	36-B-17T	1
5.	Thermometer	24-B-10	1	24-B-10	1	24-B-10	1
6.	Oven lid	24-B-25	1	30-B-25	1	36-B-25	1
7.	Warming rack	24-B-02	1	30-B-02	1	36-B-02	1
8.	Drip tray with match holder	3083	1	3083	1	3083	1
9.	Control panel w/ backburner	24-B-26T	1	30-B-26T	1	36-B-26T	1
or	Control panel w/o backburner ‡	24-B-27T	1	30-B-27T	1	36-B-27T	1
10.	Valve manifold w/ backburner	24-B-08T	1	30-B-08T	1	36-B-08T	1
or	Valve manifold w/o backburner ‡	24-B-34T	1	30-B-34T	1	36-B-34T	1
11.	Main burner ignitor assy only	24-B-04T	2	24-B-04T	3	24-B-04T	3
12.	Main burner valve w/ ignitor assy	24-B-51T	2	24-B-51T	3	24-B-51T	3
13.	Backburner valve w/ ignitor assy*	24-B-50T	1	24-B-50T	1	24-B-50T	1
14.	Large knob	24-B-37T	2	24-B-37T	3	24-B-37T	3
15.	Small knob*	24-B-38T	1	24-B-38T	1	24-B-38T	1
16.	Convertible regulator ‡	PR-4	1	PR-4	1	PR-4	1
17.	Drip tray heat shield	24-B-44	1	24-B-44	1	24-B-44	1
18.	Flex connector w/ fittings ‡	3035	1	3035	1	3035	1

\* If equipped

‡ Not shown

ROTISSERIE KIT (if equipped)

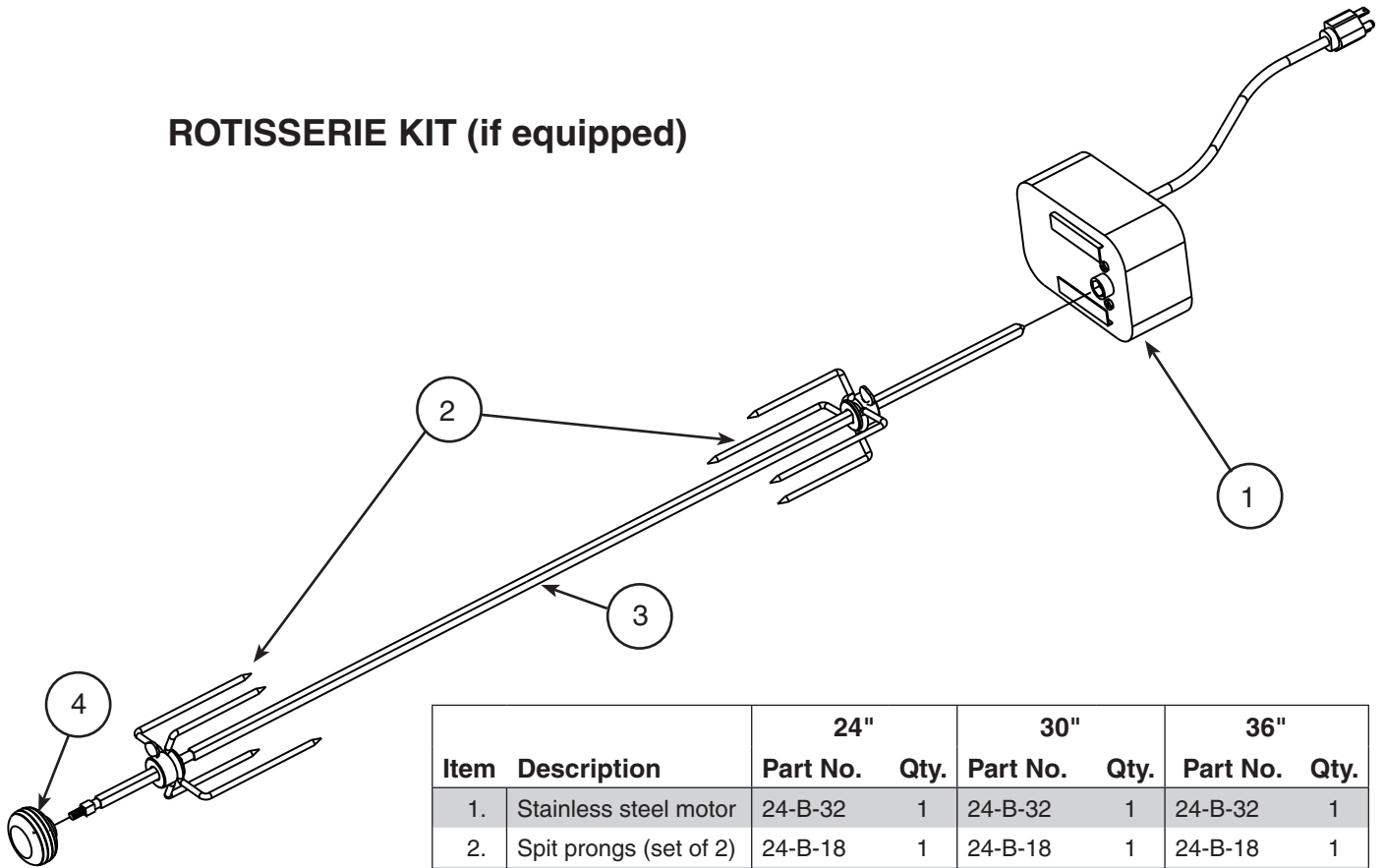

Item	Description	24"		30"		36"	
		Part No.	Qty.	Part No.	Qty.	Part No.	Qty.
1.	Stainless steel motor	24-B-32	1	24-B-32	1	24-B-32	1
2.	Spit prongs (set of 2)	24-B-18	1	24-B-18	1	24-B-18	1
3.	Spit rod $\frac{5}{8}$ " hex	24-B-33	1	30-B-33	1	36-B-33	1
4.	Handle knob	24-B-09	1	24-B-09	1	24-B-09	1

# MODEL SPECIFICATIONS

## MODEL SPECIFICATIONS TABLE

Table 1	24"	30"	36"
Main burner Quantity	2	3	3
N/P orifice drill size	1.82mm / 1.16mm	#50 / 1.16mm	#49 / #56
Backburner <sup>▲</sup> N/P orifice drill size	#53 / #64	#53 / #64	#52 / #62
Insulating liner model # (not included)*	24-IL-B	30-IL-B	36-IL-B
<b>A</b> Countertop to unit bottom <b>cut-out*</b>	8 1/2"	8 1/2"	8 1/2"
<b>B</b> Side to side non-combustible <b>cut-out*</b>	24 1/2"	30 5/8"	36 7/8"
<b>C</b> Front to back non-combustible <b>cut-out*†</b>	19 1/2"	19 1/2"	19 1/2"
<b>D</b> Control panel width non-combustible <b>cut-out‡</b>	25 1/2"	31 5/8"	37 7/8"

▲ If equipped

\* **Note:** If installing this grill in a combustible enclosure, the correct AOG insulating liner must be used. Consult liner instructions for counter cut-out dimensions and installation.

† Includes any substrate at front wall of enclosure (in the area the rear of the control panel is to sit flush against). See SUBSTRATE section on next page.

‡ Only applicable for non-combustible enclosures that have countertops with an overhang (see illustration and section below).

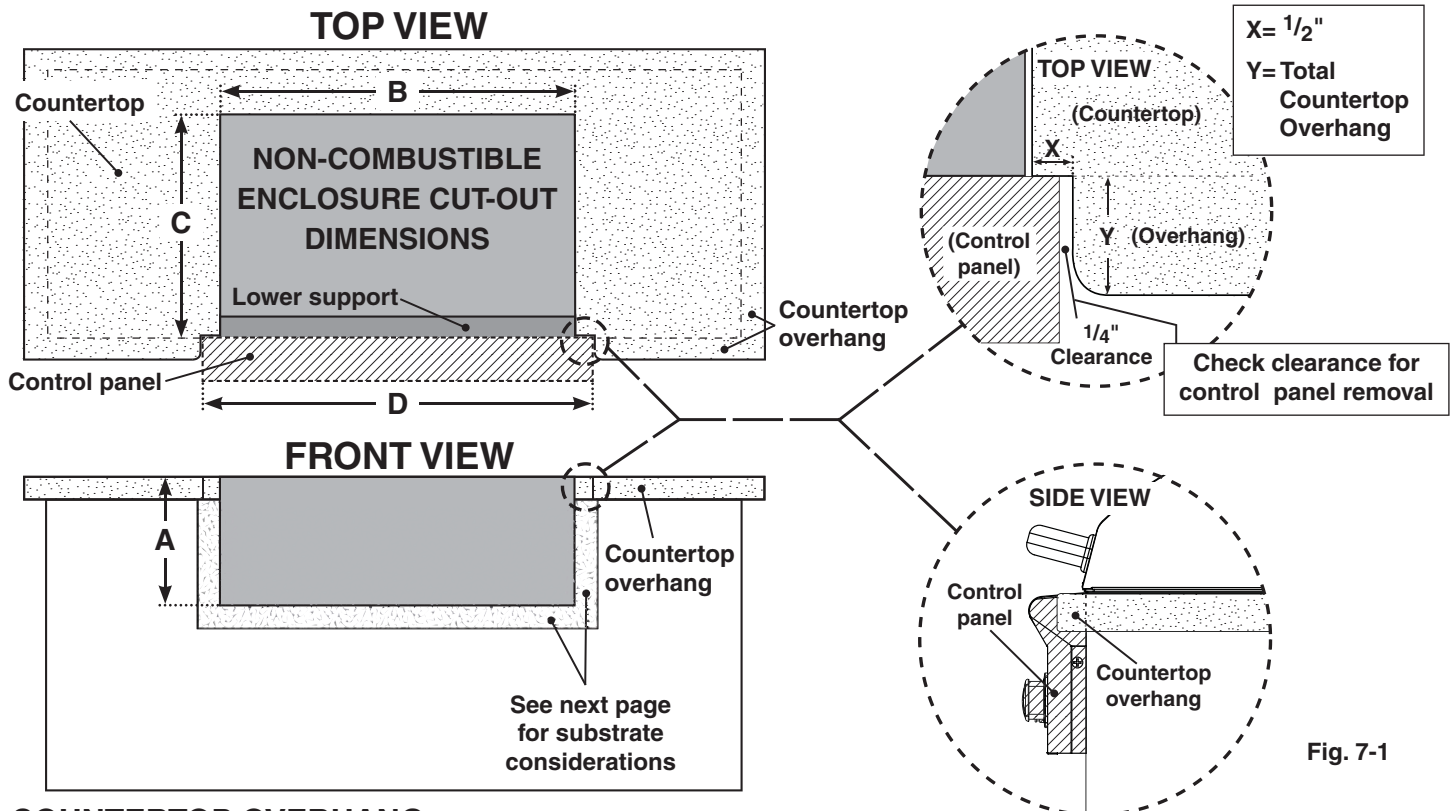

### COUNTERTOP OVERHANG

The control panel is designed to sit flush against the enclosure front wall. If the **non-combustible enclosure** countertop extends beyond the front wall, creating a countertop overhang, it must be cut flush with the front wall for the width of the control panel or a gap will be created exposing the forward portions of the left and right side grill fire walls. See illustrations above.

**Important:** FOR YOUR SAFETY, you must provide openings in the island enclosure for drainage, replacement air, and cross-ventilation of any storage area exposed to possible leakage from gas connections, the unit, or propane bottles. See the ENCLOSURE REQUIREMENTS section for details.

**SUBSTRATE**

When adding any substrate to the enclosure front wall (including tiles, stone, etc.), consider the following:

**Substrate Behind Control Panel**

Substrate + countertop "front to back" cutout must equate to **Dim. C** (see previous page) when the substrate sits flush behind the control panel.

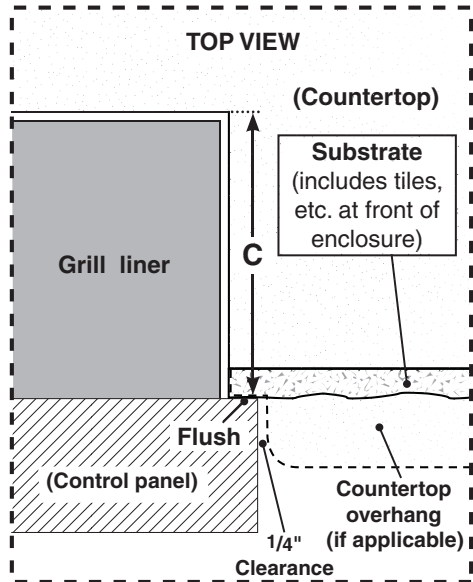

Fig. 8-1

**Substrate Alongside Control Panel**

Any additional substrate alongside the control panel does not need to be considered in **Dim. C** (see previous page), however a 1/4" clearance on each side (same as overhang) and below is required.

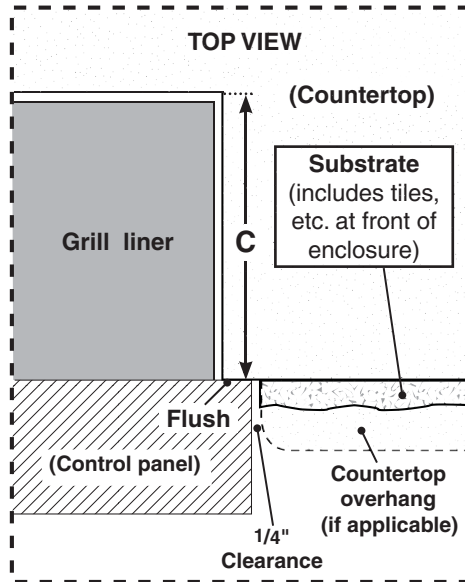

Fig. 8-2

**BUILT-IN GRILL DIMENSIONS TABLE**

Model	Height		Width		Depth
	(Top to bottom)		(Left to right)		(Front to back)
	Upper hanger to top (with oven)		Hanger to hanger (G)	Control panel width (H)	Maximum depth (I)
	Open (E)	Closed (F)			
24"	22"	11 1/2"	28"	25"	26 1/4"
30"	22"	11 1/2"	34"	31"	26 1/4"
36"	22"	11 1/2"	40 1/4"	37 1/4"	26 1/4"

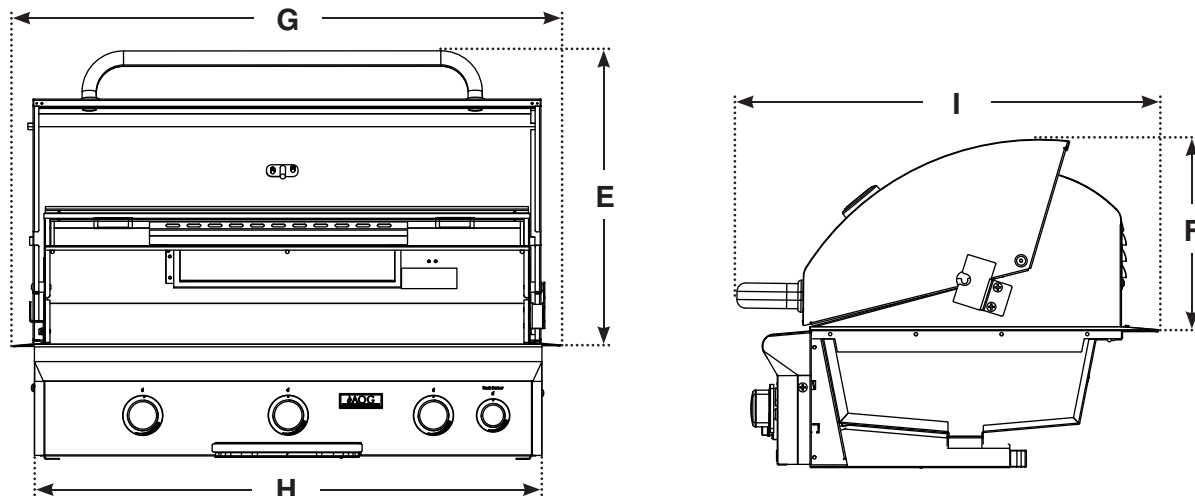

Fig. 8-3

## GRILL MAINTENANCE AND SAFETY INFORMATION

1. The outdoor grill and surrounding area **MUST** remain clear of flammable substances such as gasoline, yard debris, wood, etc.
2. The airflow through the vent space located below the control panel must remain unobstructed.
3. When using propane gas:
  - a. **The required ventilation openings in the enclosure must be clear of debris.**
  - b. **If connected to a propane cylinder, the rubber hose attached to the regulator should be carefully inspected before each use.**
  - c. **The propane cylinder, regulator, and rubber hose must be in a location not subject to temperature above 125° F (51° C).**
4. The flames on each burner burn evenly along the entire burner with a steady flame (mostly blue). If burner flames are not normal, check and clean the orifice and burner/venturi tubes for insects and insect nests. A clogged tube can lead to a fire beneath the grill. A proper flame pattern will ensure safe operation and optimal performance. Adjust the air shutter as needed (see AIR SHUTTER ADJUSTMENT).
5. The in-line gas valve or gas cylinder valve must always be shut OFF when the grill is not in use.
6. The drip collector holes must be clear and unobstructed. Excessive grease deposits can result in a grease fire.
7. The backburner cover (if equipped) must be removed before using the burner.

**WARNING: NEVER cover the *entire* cooking or grill surface with griddles or pans. Overheating will occur, and burners will not perform properly when combustion heat is trapped below the cooking surface.**

**CAUTION: NEVER spray water on a hot gas unit.**

**The grill serial identification number is located on the underside of the drip tray handle. It is recommended that the drip tray first be removed and cleaned / emptied of its contents, then turned over to view. The unit rating label is located inside the control panel.**

# INSTALLATION REQUIREMENTS

Installation must be performed by a qualified professional service technician.

This grill is designed for outdoor use only. **DO NOT** use this grill inside a building, garage, enclosed area, or under an unprotected overhead combustible construction.

See below and the **EXHAUST REMOVAL** section on the following page for details on installing under overhead construction.

**DO NOT** use this grill in or on a recreational vehicle or boat.

**Important:** If installing this grill in a combustible surround, the correct AOG insulating liner must be used.

**Important:** Refer to the information below to ensure all required clearances are met.

**The grill must have a minimum clearance of 18" from combustible materials/items AT ALL TIMES.**

## Overhead Construction Requirements (if applicable)

Non-combustible overhead construction: A 6 foot clearance is required between the countertop and the construction above (Fig. 10-1).

Combustible overhead construction: A 6 foot clearance is required between the countertop and the construction above. A vent hood (see EXHAUST REMOVAL section) or an AOG combustible overhead protection kit is required directly above the grill. See Fig. 10-1. **Vent hoods and protection kits are available, contact your local dealer.**

## Side and Rear Wall Clearances

For the minimum clearances between the grill and any side or rear walls, your setup must fall within one (or more) of the following:

### A. Clearance between grill and strictly non-combustible wall (i.e. brick wall, see Fig. 10-2)

- The grill must have a minimum of 4" right, left, and rear clearance from any non-combustible wall. (To allow for proper ventilation and prevent dangerous overheating.)

### B. Clearance between grill and a protected combustible wall (i.e. a non-combustible wall in front of a combustible wall to serve as a barrier. This can be accomplished by brick, or a metal stud finished with non-combustible substrate, see Fig. 10-3)

- The grill must have a minimum of 14" right, left, and rear clearance from the protected combustible wall. (The 4" non-combustible material plus an additional 10" clearance between the grill and protected wall.)

### C. Clearance between grill and combustible wall

- The grill must have a minimum of 18" right, left, and rear clearance from any combustible wall (see Fig. 10-4).

## Backsplash Clearance (if applicable)

If a non-combustible backsplash exists, it must have a minimum of a 4" clearance from the rear of the grill (to allow for proper ventilation and prevent dangerous overheating). See Fig. 10-5.

**Important:** This 4" backsplash clearance must first be met prior to any non-combustible walls beginning behind it.

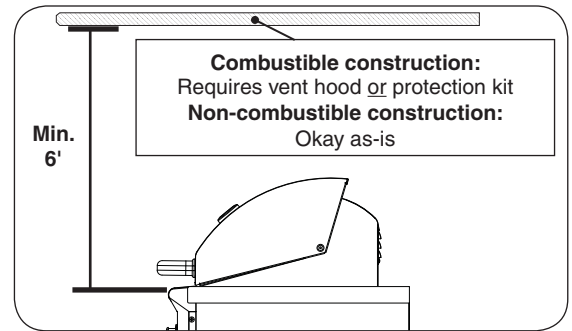

Fig. 10-1 Overhead requirements

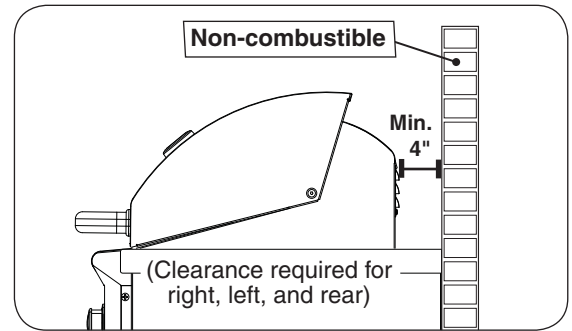

Fig. 10-2 Clearance 'A' Diagram

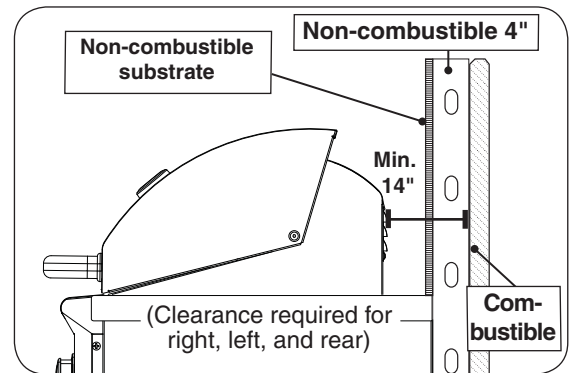

Fig. 10-3 Clearance 'B' Diagram

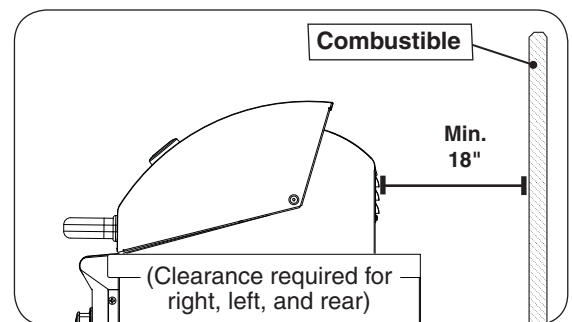

Fig. 10-4 Clearance 'C' Diagram

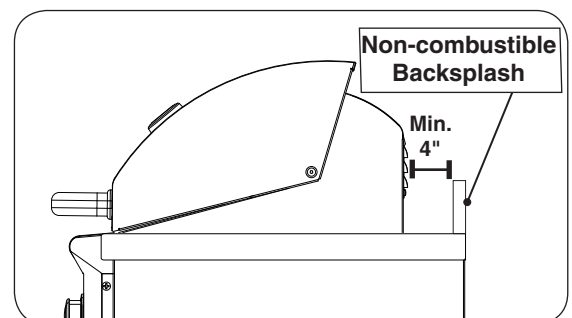

Fig. 10-5 Backsplash clearance

## INSTALLATION REQUIREMENTS (Cont.)

The control panel **MUST** remain removable for servicing (see PARTS LIST).

### ENSURE PROPER COMBUSTION AIR AND COOLING AIRFLOW

Proper airflow (Fig. 11-1) **MUST** be maintained for the grill to perform as it was designed. If airflow is blocked, overheating and poor combustion will result. Do not block the 1" (2.5 cm) front air inlet along the bottom of the control panel or more than 75% of the cooking grid surface with pans or griddles.

**Note:** The 1" (2.5 cm) front air space also allows access to the drip tray.



Fig. 11-1  
Ventilation Diagram

### EXHAUST REMOVAL

If the grill is installed under an overhead structure that is constructed of non-combustible material: an exhaust hood is recommended. See below.

If the grill is installed under an overhead structure that is constructed of combustible material: an exhaust hood is required. See below.

**Note:** An alternative to an exhaust removing vent hood is an AOG combustible overhead protection kit. See previous page.

### When using an exhaust hood:

The cooking grid area must be covered by an exhaust hood (with a vent) larger than the cooking surface. Refer to manufacturer specifications. An exhaust fan with a rating of 1,000 CFM (cubic feet per minute) (472 liters per second) or more may be necessary to effectively remove smoke and other cooking by-products from the area under the hood. **RHP Vent Hoods are available, contact your local dealer.**

**THIS UNIT MUST NOT BE LOCATED IN A FULLY ENCLOSED AREA OF ANY KIND.**

### GAS-SUPPLY PLUMBING REQUIREMENTS

For natural gas or a household propane system, rigid 1/2" (1.3 cm) or 3/4" (1.9 cm) black steel pipe or local code-approved pipe is required to conduct the gas supply to the unit. Contact your local gas supplier. Connect this pipe to the required C.S.A.-approved stainless-steel flex connector (attached). An NPT adapter has been provided for 1/2" pipe. **DO NOT use a rubber hose within the grill enclosure.** Apply only joint compounds that are resistant to all gasses to all male pipe fittings except flare fittings. Make sure to tighten every joint securely.

**Note:** If 1/2" (1.3 cm) pipe is used with **natural gas**, it should be no longer than 20' (6.1 meters).

**Important:** An external valve (with a removable key) in the gas line is necessary for safety when the grill is not in use. It also provides for convenient maintenance.

**CAUTION:** Wind blowing into or across the rear oven lid vent (Fig. 11-2) can cause poor performance and/or dangerous overheating. Orient the grill so that the prevailing wind blows toward the front of the grill (Fig. 11-3).

### GAS SUPPLY AND MANIFOLD PRESSURES:

For **natural gas** - normal 7" (17.78 cm) water column (w.c.), minimum 5" (12.7 cm), maximum 10 1/2" (26.7 cm). For **propane gas** - normal 11" w.c., minimum 10" (25.4 cm), maximum 13" (33 cm).

### INCORRECT

Rear oven lid vent



YOU MUST PROTECT REAR OVEN VENT FROM PREVAILING WIND

Fig. 11-2

### CORRECT



PLACE GRILL SO PREVAILING WIND BLOWS TOWARD FRONT OF GRILL

Fig. 11-3

# ENCLOSURE REQUIREMENTS

FOR YOUR SAFETY, you must provide the openings listed below for drainage, replacement air, and cross-ventilation of any storage area exposed to possible leakage from gas connections, the unit, or propane cylinders.

One side of the enclosure can be left completely open to the outside, OR 4 ventilation openings must be created:

## NATURAL GAS INSTALLS

Two of the openings are to be at the top level (approx. 4" below the countertop) and on opposite walls of the enclosure. 2 more openings must be at the floor level (no more than 5" above the floor) and on opposite sides of the enclosure. Each opening must have a minimum of 10 sq. in. of free area. To achieve the proper ventilation, you may drill a series of holes, omit the grout from masonry joints, or replace a brick with a hardware cloth screen. If the floor in the cabinet is raised and the space beneath the cabinet is open to the outside, the lower ventilation openings may be in the floor. Reference Fig. 12-1.

## PROPANE GAS INSTALLS (HOUSEHOLD & CYLINDER)

Two of the openings are to be at the cylinder valve level (approx. 16" above the floor) and on opposite walls of the enclosure. 2 more openings must be at the floor level (no more than 5" above the floor) and on opposite sides of the enclosure. Each opening must have a minimum of 10 sq. in. of free area. To achieve the proper ventilation, you may drill a series of holes, omit the grout from masonry joints, or replace a brick with a hardware cloth screen. If the floor in the cabinet is raised and the space beneath the cabinet is open to the outside, the lower ventilation openings may be in the floor. Reference Fig. 12-1.

## WHEN A PROPANE CYLINDER IS USED

When a propane cylinder is installed inside of the enclosure, the guidelines below **MUST** be followed. **FAILURE TO DO SO MAY CAUSE DAMAGE TO YOUR UNIT AND/OR PERSONAL INJURY.** Reference Fig. 12-2 for an example.

- Only a C.S.A. 1/2" listed stainless steel connector can be connected to the grill.
- The supplied regulator is not required when using a propane cylinder.
- The regulator/hose assembly coming from the propane cylinder can only be connected to the above mentioned grill flex connector. **DO NOT connect the regulator/hose assembly directly to the grill.** An adapter will be required.
- A heatshield must be installed to protect the regulator/hose assembly and propane cylinder valve.
- **AOG offers a propane cylinder door with tank tray to meet the cylinder install requirements. See Fig. 12-3.**

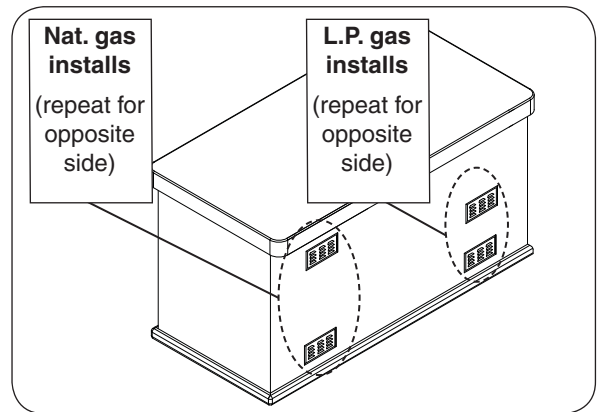

Fig. 12-1 Ventilation detail

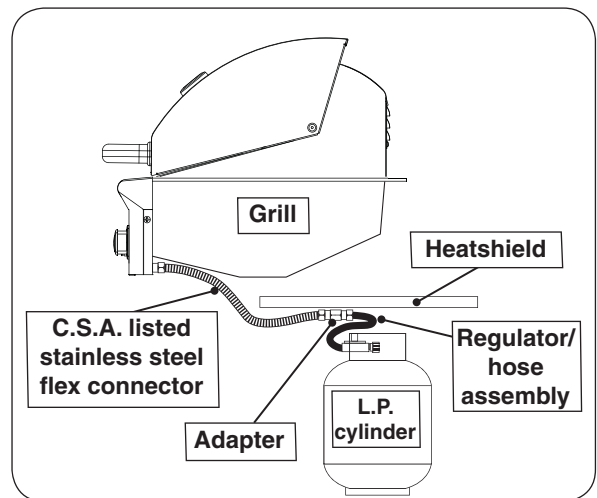

Fig. 12-2 Propane cylinder orientation

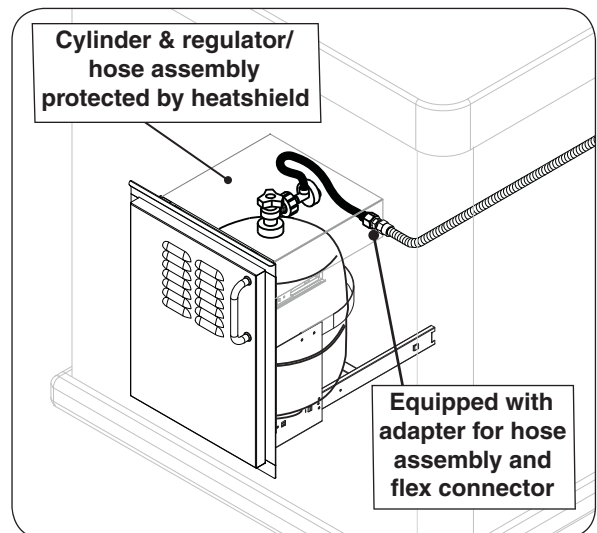

Fig. 12-3 Optional AOG door w/tank tray

## COUNTER PREPARATION

Consult Table 1 for non-combustible enclosure cut-out dimensions. An AOG insulating liner must be used if any supporting construction is combustible. Consult the instructions that come with the liner for dimensions and additional installation information before beginning the installation.

This outdoor built-in grill must be supported by the stainless-steel hanger extending from the upper portion of the grill. The hanger rests on the left, right, and back of the countertop.

The control panel is designed to sit flush against the enclosure front wall (see Fig. 13-2). If the non-combustible countertop extends beyond the front wall, creating a countertop overhang (see Fig. 13-1), it must be cut flush with the front wall for the width of the control panel or a gap will be created exposing the forward portions of the left and right side grill fire walls. See the MODEL SPECIFICATIONS section.

**Note:** It is not necessary to remove the control panel or knobs to install this unit.

## CONNECT THE GAS SUPPLY

**Always ensure the orifices and regulator are set for the gas type your unit is to be installed to.**

**For propane cylinders:**

For connecting a propane unit to a portable propane tank, read the safety warnings and follow the instructions in the section SAFE USE AND MAINTENANCE OF PROPANE GAS CYLINDERS.

**Note:** When a propane cylinder is installed inside of the enclosure, the guidelines found in the ENCLOSURE REQUIREMENTS section MUST be followed.

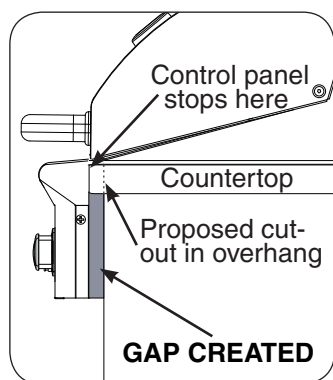

Fig. 13-1

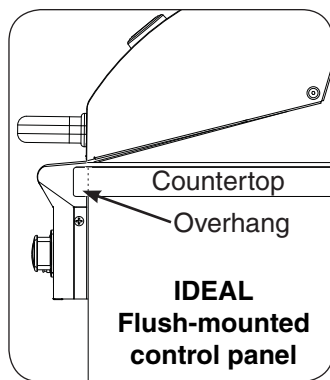

Fig. 13-2

**For household propane or natural gas units:**

THE ATTACHED FLEX LINE AND REGULATOR MUST BE PROPERLY ATTACHED TO A RIGID GAS SUPPLY PIPE. See fig. 13-3.

**CAUTION:** Use only C.S.A. listed stainless-steel flex connectors within the enclosure.

### WARNING

**A rubber or plastic connector will rupture or leak, resulting in an explosion or serious injury if used inside the appliance enclosure.**

1. Route the attached flex connector with regulator (located underneath the grill) to the gas-supply stub. (An adapter is required if the gas-supply stub is other than 1/2" in diameter.)
2. **Turn OFF the gas supply at the source.** Then connect the regulator to the gas-supply stub. Use pipe joint compound that is resistant to all gasses on the male pipe fitting and tighten securely. **DO NOT use pipe joint compound to connect flare fittings.**

**Note:** The regulator may need to be disconnected from the flex connector to make the proper connections. Reconnect the flex to the regulator if removed.

3. Turn all burner control knobs to the **OFF** position. Turn the gas supply on. Then carefully check all gas connections for leaks with a brush and half-soap/half-water solution before lighting. **Never use a match or open flame to test for leaks.**
4. Close the dedicated gas-supply shut-off valve, then slide the grill into place. Do not to pinch, kink, or damage the gas connector line.

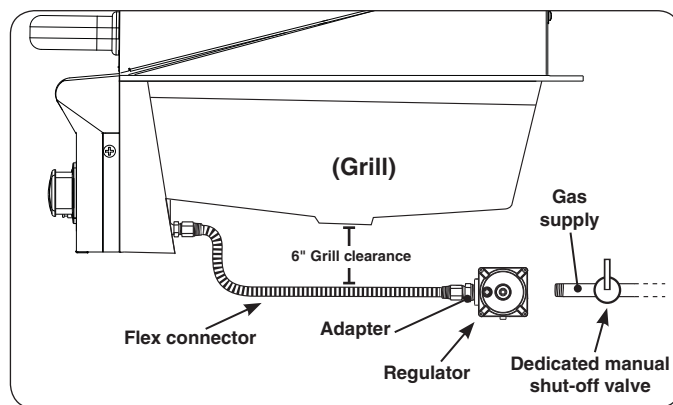
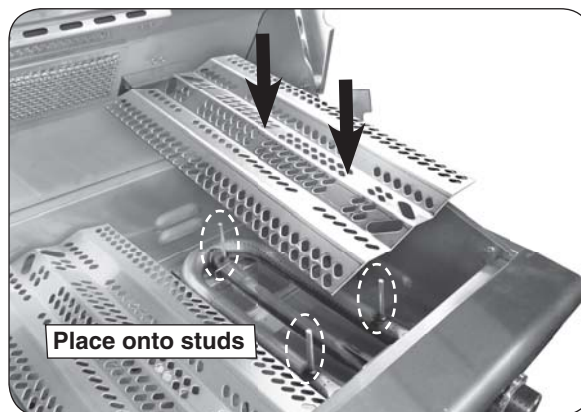

Fig. 13-3

## INSTALL THE VAPORIZER PANELS

Place the vaporizer panels directly onto the studs on the burners. The panels allow heat from the burners to be evenly distributed throughout the cooking area. The panels are stainless steel and will heat and cool quickly, making your barbecue very responsive to the changes you specify in grill temperature. They are rust resistant and may be cleaned with standard oven cleaners. Some discoloring will be seen with use. This is normal for stainless steel and does not affect the function.



**Fig. 14-1** Install vaporizer panels

# SAFE USE & MAINTENANCE OF PROPANE GAS CYLINDERS

## IMPORTANT FOR YOUR SAFETY

### READ AND FOLLOW ALL WARNINGS PROVIDED WITH THE PROPANE-GAS CYLINDER.

When operating this appliance with a propane-gas cylinder, these instructions and warnings **MUST** be observed.

**FAILURE TO DO SO MAY RESULT IN A SERIOUS FIRE OR EXPLOSION.**

## CYLINDER/CONNECTOR REQUIREMENTS

- a. Propane-gas cylinders, valves, and hoses must be maintained in good condition and must be replaced if there is visible damage to either the cylinder or valve. If the hose is cut or shows excessive abrasion or wear, it must be replaced before using the gas appliance (see e.).
- b. This unit, when used with a cylinder, should be connected to a standard 5-gallon (20 lb.) propane-gas cylinder equipped with an OPD (Overfill Prevention Device). The OPD has been required on all cylinders sold since October 1, 1998, to prevent overfilling.
- c. Cylinder dimensions should be approximately 12" (30.5 cm) in diameter and 18" (45.7 cm) high. Cylinders must be constructed and marked in accordance with the *Specifications for Propane Gas Cylinders of the U.S. Department of Transportation (D.O.T.)* or the National Standard of Canada, *CAN/CSA-B339, Cylinders, Spheres, and Tubes for Transportation of Dangerous Goods*.
- d. The cylinder used must include a collar to protect the cylinder valve, and the cylinder supply system must be arranged for vapor withdrawal.
- e. The pressure regulator and hose assembly used must match the specification for Type I by *ANSI Z 21.58-2005/CGA 1.6-2005* (see Fig. 15-1).
- f. The propane-gas cylinder valve must be equipped with a cylinder connection coupling device, described as Type I in the standard defined in paragraph e. above. This device is commonly described as an Acme thread quick coupler.
- g. If the propane-gas cylinder comes with a dust plug, place the dust cap on the cylinder valve outlet whenever the cylinder is not in use.

## QUICK COUPLER OPERATION

**To connect the regulator/hose assembly to the propane-gas cylinder valve fitting:** Press the hand nut on the regulator over the Acme thread fitting on the cylinder valve. Turn the hand nut clockwise to engage the threads and tighten until snug.

The use of pliers or a wrench should not be necessary. Only cylinders marked "propane" may be used.

**To disconnect:** Turn the hand nut counterclockwise until detached (Fig. 15-1).

**Important:** Before using the unit, and after each time the cylinder is removed and reattached, check the hose for wear (see a.) and check all connections for leaks. Turn off the unit valves and open the main cylinder valve, then check connections with soapy water. Repair any leaks before lighting the unit.

**CAUTION:** Always turn the propane cylinder main valve off after each use, and before moving the unit and cylinder or disconnecting the coupling. This valve must remain closed and the cylinder disconnected while the appliance is not in use, even though the gas flow is stopped by a safety feature when the coupler is disconnected.

**Carefully** inspect the hose assembly each time before the gas is turned on. A cracked or frayed hose must be replaced immediately.

If the appliance is stored indoors, the cylinder must be disconnected and removed. Disconnected cylinders must be stored outdoors, out of the reach of children, with threaded valve plugs tightly installed, and must not be stored in a building, garage, or any other enclosed area.

## FOR YOUR SAFETY

- a. DO NOT store a spare propane-gas cylinder under or near this appliance.
- b. NEVER fill the cylinder beyond 80-percent full.
- c. IF THE INFORMATION IN a. AND b. IS NOT FOLLOWED EXACTLY, A FIRE CAUSING DEATH OR SERIOUS INJURY MAY OCCUR.

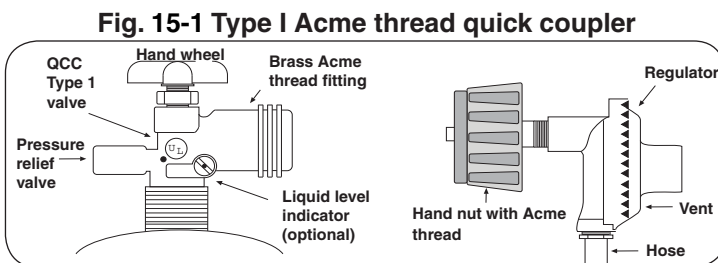

**For propane ventilation requirements, see the ENCLOSURE REQUIREMENTS section.**

# UTILISATION SÛRE ET ENTRETIEN DES CYLINDRES DE GAZ DE PROPANE

## IMPORTANT POUR VOTRE SÛRETÉ

LISEZ ET SUIVEZ TOUS LES AVERTISSEMENTS ÉQUIPÉS DE VOTRE CYLINDRE DE GAZ DE PROPANE.

En actionnant cet appareil avec un cylindre de gaz de propane ON DOIT observer ces instructions et avertissements.

**LE MANQUE DE FAIRE AINSI PEUT AVOIR COMME CONSÉQUENCE UNE INCENDIE OU UNE EXPLOSION SÉRIEUSE.**

### CYLINDRE ET CONDITIONS ET CARACTÉRISTIQUES DE CONNECTEUR

- Des cylindres et les valves de gaz de propane doivent être maintenus en bon état et doivent être remplacés s'il y a des dommages évidents au cylindre ou à la valve.
- Ce gril, une fois utilisé avec un cylindre, devrait être relié à un gallon de la norme 5 (20lb.) cylindre de gaz de propane équipé d'un OPD (remplissez au-dessus du niveau le dispositif d'empêchement). L'OPD a été exigé sur tous les cylindres vendus depuis octobre 1.1998 pour empêcher le remplissage excessif.
- Les dimensions de cylindre devraient être approximativement 12"(30.5cm) de diamètre et 18" (45.7cm) hauts. Des cylindres doivent être construits et marqués selon les caractéristiques pour des cylindres de gaz de propane du département des ETATS-UNIS du transport (D.O.T.) ou le niveau national du Canada, du CAN/CSA-B339, des cylindres, des sphères et des tubes pour le transport des marchandises dangereuses.
- Le cylindre doit inclure un collier pour protéger la valve de cylindre et le circuit d'alimentation de cylindre doit être assuré le retrait de vapeur.
- Le régulateur de pression et l'ensemble de tuyau utilisé doivent assortir les spécifications pour le type I par ANSI Z 21.58-2005/CGA 1.6-2005 (voir la fig. 16-1).
- La valve de cylindre de gaz de propane doit être équipée d'un dispositif d'accouplement de raccordement de cylindre, décrit comme type I dans la norme définie dans le e. de paragraphe ci-dessus. Ce dispositif est généralement décrit comme coupleur rapide de fil de point culminant.
- Si votre cylindre de gaz de propane vient avec une prise de la poussière, placez le bouchon anti-poussière sur la sortie de valve de cylindre toutes les fois que le cylindre n'est pas en service.

### OPÉRATION DE COUPLEUR RAPIDE

**Pour relier le régulateur/hose à l'ajustage de précision de valve de cylindre de gaz de propane:** Serrez l'écrou de main sur le régulateur au-dessus de l'ajustage de précision de fil de point culminant sur la valve de cylindre. Tournez l'écrou de

main dans le sens des aiguilles d'une montre pour engager les fils et pour serrer jusqu'à ce que douillettement. L'utilisation des pinces ou de la clé ne devrait pas être nécessaire. Seulement le propane marqué par cylindres doit être employé.

**Pour débrancher:** Tournez l'écrou de main dans le sens contraire des aiguilles d'une montre jusqu'à isolé (fig. 16-1).

**Important:** Avant d'employer le gril, et ensuite chaque fois que le cylindre est enlevé et rattaché, examinez tous les raccordements pour déceler les fuites. Arrêtez les valves de gril et ouvrez la valve principale de cylindre, puis vérifiez les raccordements avec de l'eau savonneux. Réparez toutes les fuites avant d'allumer le gril.

**ATTENTION:** Tournez toujours la valve principale de cylindre de propane au loin après chaque utilisation, et avant de déplacer le gril et le cylindre, ou débrancher l'accouplement. Cette valve doit rester fermée et le cylindre a débranché alors que l'appareil n'est pas en service, quoique l'écoulement de gaz soit arrêté par un dispositif de sûreté quand le coupleur est débranché.

**Inspectez soigneusement** l'ensemble de tuyau chaque fois avant que le gaz soit allumé. Un tuyau fissuré ou effiloché doit être immédiatement remplacé.

Si l'appareil est stocké à l'intérieur, le cylindre doit être disconnected et a enlevé. Des cylindres Disconnected doivent être stockés dehors, hors de la portée des enfants, avec les prises de valve filettées étroitement installées, et ne doivent pas être stockés dans un bâtiment, le garage, ou n'importe quel autre secteur inclus.

### POUR VOTRE SÛRETÉ

- Ne stockez pas un cylindre de gaz disponible de propane dessous ou ne vous approchez pas de cet appareil.
- Ne remplissez jamais cylindre au delà de 80 pour cent de plein.
- SI L'INFORMATION DANS "A" ET "B" N'EST PAS SUIVIE EXACTEMENT, UN FEU CAUSANT LA MORT OU DES DOMMAGES SÉRIEUX PEUT SE PRODUIRE.

**Fig. 16-1 type coupleur rapide de fil de point culminant d'I**

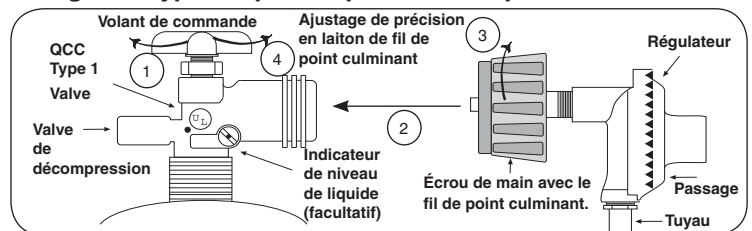

**Pour la ventilation de propane, voir la section sur les exigences de boîtier.**

# IDENTIFICATION OF GRILL CONTROLS

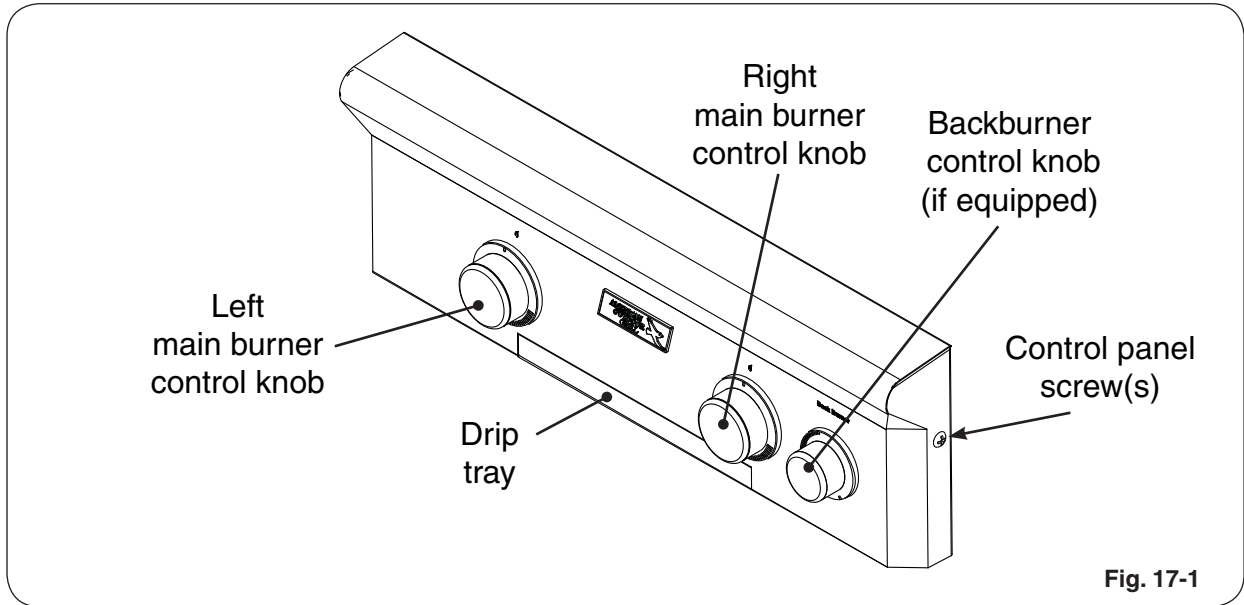

24" model controls

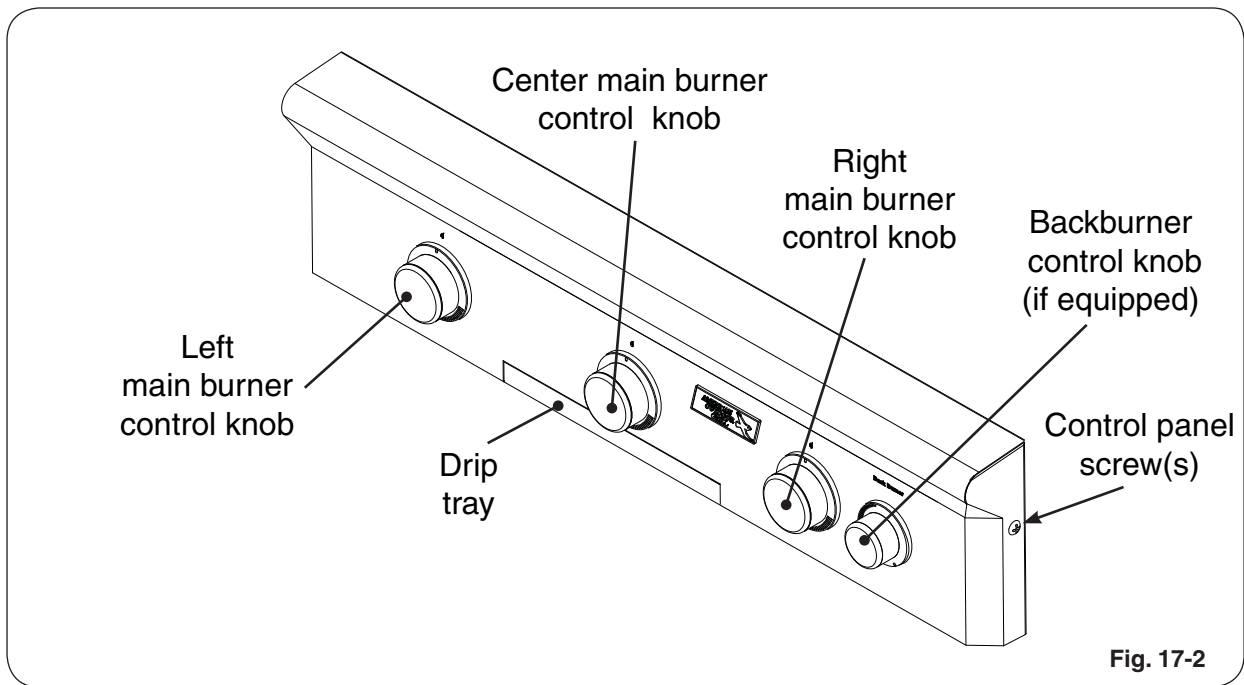

30" and 36" model controls

# ALLUMAGE DES INSTRUCTIONS (D'ALLUMAGE)

Lisez toutes les instructions avant l'allumage, et suivez ces instructions chaque fois vous lumière le unité.

## ALLUMAGE COMMANDE ECLAIRAGE

**Note:** N'ouvrez pas plus d'une valve à la fois pour l'éclairage électronique ou manuel.

1. Ouvrez les couvercles ou enlevez les couvertures des brûleurs pour être Lit.
2. Tournez tous les boutons de commande de gaz à leurs positions de repos.
3. Allumez le gaz à sa source.

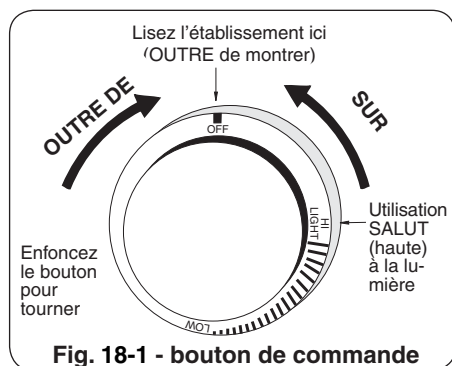

4. Appuyez sur le bouton de commande désiré, puis tout en appuyant son tour dans le sens antihoraire à la position HI LIGHT. Une fois que le brûleur s'allume, relâchez le bouton.

**Note:** En tournant le bouton créera un "clic" sonore. Le pilote de s'enflammer à ce point, l'allumage du brûleur.

**ATTENTION :** Si un brûleur ne s'allume pas dans deux ou trois (2-3) secondes suivant la mise sur le bouton de commande, appuyez sur le bouton et le tourner vers la position OFF. ATTENDEZ CINQ (5) MINUTES avant de répéter l'étape 4. Si vous sentez le gaz, suivez les instructions sur la couverture de ce manuel. Si les brûleurs ne s'allument toujours pas après que plusieurs tentatives, se rapportent aux instructions pour l'éclairage manuel.

5. Répétez l'étape 4 pour que chaque brûleur additionnel soit Lit.

### EN EMPLOYANT UN RÉSERVOIR DE PROPANE PORTATIF

Des réservoirs de propane sont équipés d'un dispositif d'arrêt de sûreté qui peut ne pas causer le bas ou aucunes pression de gaz/flamme aux brûleurs si le fonctionnement et l'allumage des instructions ne sont pas suivis exactement (voir la note importante dans la section de dépannage pour plus de détails.)

## ÉCLAIRAGE MANUEL

**ATTENTION:** Attendez toujours cinq (5) minutes le gaz pour se dégager après que n'importe quelle tentative non réussie d'éclairage.

1. Suivez les étapes 1 à 3 (à gauche).
2. Insérez soit un brûlant long baril briquet au butane, un match à longue tige de brûlure, ou une allumette en feu détenues par un titulaire d'extension de fil (Fig. 18-2) À travers les grilles de cuisson du brûleur (Fig. 18-3). Pour backburners, maintenez la flamme contre le matériau perforé de la veilleuse.
3. Tout en maintenant le match ou flamme d'un briquet à proximité du brûleur, appuyez sur le bouton de contrôle approprié et en appuyant son tour dans le sens antihoraire à la position **LIGHT HI**. Retirez le briquet ou des allumettes quand le brûleur s'allume, puis relâchez le bouton de commande.
4. Si le brûleur ne s'allume pas, **appuyez immédiatement sur le bouton et tournez la valve sur OFF**. Attendez cinq (5) minutes avant de répéter les étapes 2 à 4 des instructions du manuel d'éclairage.



**Fig. 18-2 - Titulaire de match**

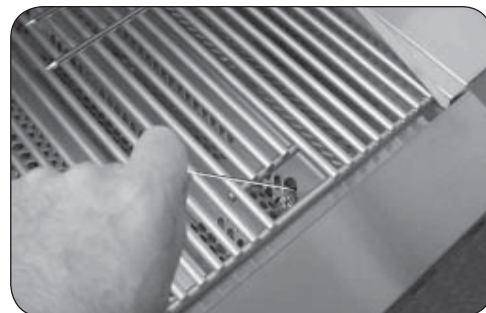

**Fig. 18-3 - MAllumage manuel**

## ARRÊT DU UNITÉ

Pour couper le unité, diminuez chaque bouton de commande de valve et tout en pressant tour il dans le sens des aiguilles d'une montre à la position de repos.

Fermez toujours la valve de la fourniture de gaz après chaque utilisation du unité.

# LIGHTING (IGNITION) INSTRUCTIONS

Read all instructions before lighting, and follow these instructions each time you light the unit.

## SPARK IGNITION LIGHTING

**Note:** DO NOT turn on more than one valve at a time for either electronic or manual lighting.

1. Open lid(s) or remove cover(s) from burner(s) to be lit.
2. Turn all gas control knob(s) to their **OFF** position(s).
3. Turn on the gas at its source.

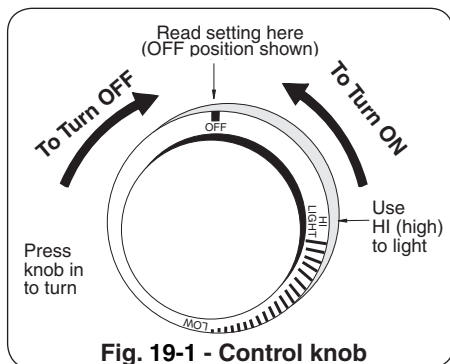

Fig. 19-1 - Control knob

4. Depress the desired control knob, then while pressing turn it counterclockwise to the **HI LIGHT** position. Once the burner lights, release the knob.

**Note:** Turning the knob will create a “click” sound. The pilot will ignite at this point, lighting the burner.

**CAUTION:** If a burner does not light within two to three (2-3) *seconds* of turning on the control knob, depress the knob and turn it to the **OFF** position. **WAIT FIVE (5) MINUTES** before repeating step 4. If you smell gas, follow the instructions on the cover of this manual. If the burners still do not light after several attempts, refer to the instructions for manual lighting.

5. Repeat step 4 for each additional burner to be lit.

## WHEN USING A PORTABLE PROPANE TANK

Propane tanks are equipped with a safety shutdown device that may cause low or no gas pressure/flame at the burners if operating and lighting instructions are not followed exactly (See important note in the TROUBLESHOOTING section for more details.)

## MANUAL LIGHTING

**CAUTION:** Always wait five (5) minutes for gas to clear after any unsuccessful lighting attempt.

1. Follow steps 1 through 3 (left).
2. Insert either a burning long-barrel butane lighter, a burning long-stem match, or a burning match held by a wire extension holder (Fig. 19-2) through the cooking grids to the burner (Fig. 19-3). For backburners, hold the flame against the perforated material of the backburner.
3. While holding the match or lighter flame next to the burner, depress the appropriate control knob and while pressing turn it counterclockwise to the **HI LIGHT** position. Remove the lighter or match when the burner lights, and release the control knob.
4. If the burner does not light, **immediately depress the knob and turn the valve to OFF**. **WAIT FIVE (5) MINUTES** before repeating steps 2 through 4 of the MANUAL LIGHTING instructions.



Fig. 19-2 - Match holder

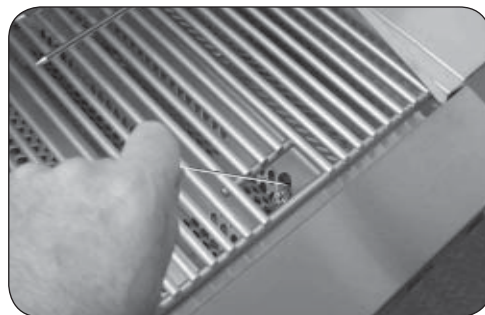

Fig. 19-3 - Manual lighting

## SHUTTING OFF THE UNIT

To shut off the unit, depress each valve control knob and while pressing turn it clockwise to the **OFF** position.

Always close the valve from the gas supply after each use of the unit.

## ROTISSERIE INSTRUCTIONS (IF EQUIPPED)

**CAUTION: WHEN USING THE BACKBURNER; KEEP THE OVEN LID CLOSED TO PREVENT HEAT LOSS, PROVIDE PROPER CONVECTION, AND PROVIDE PROPER VENTING. THIS WILL ENSURE EVEN COOKING TEMPERATURES.**

**DO NOT KEEP YOUR OVEN LID OPEN DURING ROTISSING, AS THIS MAY CAUSE PERSONAL INJURY, OR IN SOME CASES, IN WINDY CONDITIONS, DAMAGE TO THE GRILL.**

**DO NOT USE THE ROTISSERIE MOTOR IN THE RAIN. DO NOT LEAVE THE MOTOR ON THE GRILL WHEN NOT IN USE.**

1. Remove the warming rack and cooking grids from the barbecue. The vaporizer panels may also be removed if required.

**Tip:** Aluminum foil or a baking pan is recommended and may be placed over the main burners / vaporizer panels, a little forward of center, to catch excess drippings from the meat.

2. Attach the rotisserie motor to the rotisserie mounting on the right side of your barbecue by sliding the bracket attached to the motor onto the tab on the right of the barbecue. The motor should be installed so that the spit rod will fit into the motor drive socket from the left.

3. Slide the left spit prong onto the rod (and tighten), the meat onto the rod and into the prong, followed by the right spit prong onto the rod and into the meat. Tighten the right spit prong. Be sure the meat is centered and balanced as well as possible.
4. Insert the pointed end of the rod into the motor drive socket and the groove next to the handle into the left support bracket.
5. Plug in (if necessary) and turn on the rotisserie motor.
6. Light backburner per lighting instructions in this manual (or on drip tray handle) and close oven lid.
7. Allow the backburner to preheat for approximately 10 minutes on **HI LIGHT** setting.

**Note:** When burning properly, the backburner grating will glow red. The first time it is used the backburner may smoke a little.

**Important:** Turn the backburner to low or off when stopping the rotisserie to prevent overcooking.

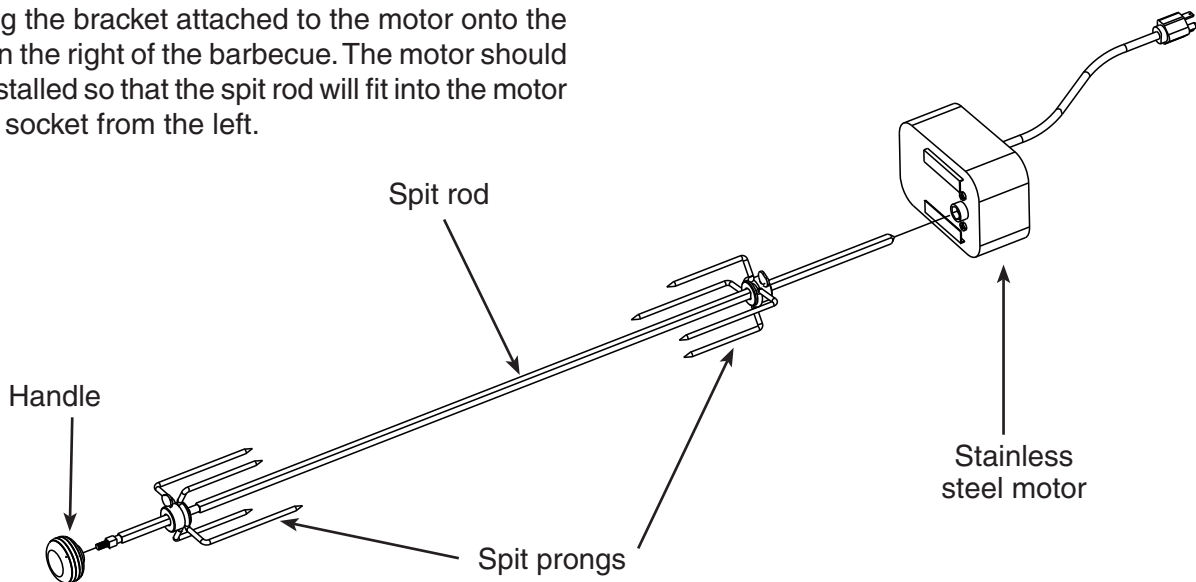

## ACCESSORIES

### THE VAPORIZER PANEL(S)

Place each vaporizer panel directly on a burner or burner pair. Center each panel over the burner, oriented as shown in Fig. 21-1.

**Note:** This allows heat from the burners to be evenly distributed throughout the cooking area. The vaporizer panels heat and cool quickly, making the grill very responsive to the changes in heat from the burners.



Fig. 21-1

### WARMING RACK (if equipped)

The warming rack (Fig. 21-2) is packed separately.

To install the warming rack, lift the front of the rack slightly and insert the rack hangers into the two holes in the back of the inner oven hood. Then lower the front of the rack into a level position to lock the rack in place.

To remove the warming rack, lift up on the front of the rack until the rack hangers pull free from their supporting holes.

**Note:** Removing the warming rack before using the rotisserie will leave more clearance for the meat being cooked. (if applicable)



Fig. 21-2 Warming rack in place inside oven

### THE DRIP TRAY

The drip collection system allows you to brush or scrape excess dried residue from the grilling area directly into the drip tray (see the DRIP TRAY section for more information).

# DRIP TRAY

The drip collection system in this barbecue is part of the unit's main frame and is located below the burners. The drip collector has slots that will allow excess drippings to fall through during cooking, while separating the firebox from the drip tray. Clean the drip tray after each use.

The drip collector allows you to brush or scrape residue from the barbecue's inner liner into the drip tray. Following the manufacturers instructions and regular cleaning of the barbecue's interior with oven cleaner, will help to prevent grease fires.

**Note:** When cleaning the drip tray, the drip tray heat shield will first need to be removed to properly clean/empty the tray of its contents. See section below.

**Note:** There are easy to follow lighting instructions etched onto the top of the drip tray handle.

## DRIP TRAY HEAT SHIELD

The drip tray heat shield provides protection to the grill controls from high heat. When cleaning the drip tray, the heat shield must be removed. To re-install, slide the front lip of the heat shield into the front portion of the drip tray, then orient the front and side tabs as shown in Fig. 22-2 to properly drop in place.

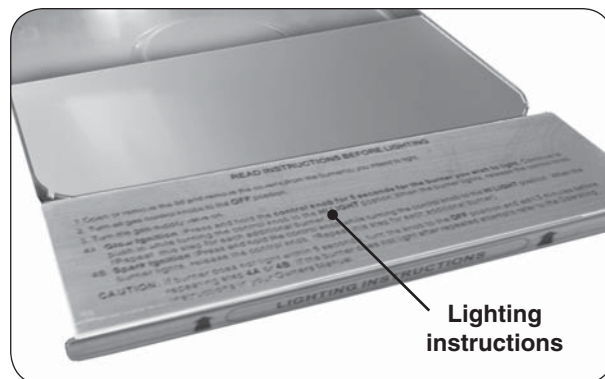

**Fig. 22-1** Lighting instruction plate

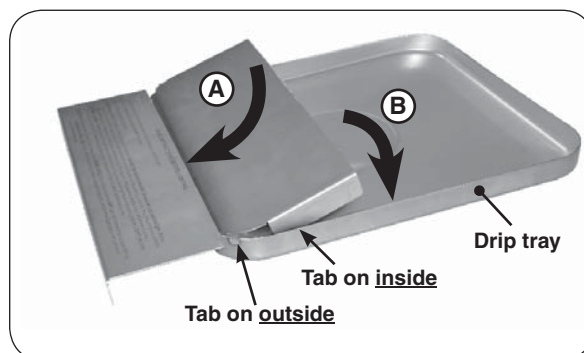

**Fig. 22-2** Install drip tray heat shield

## CARE & CLEANING

APPLIANCE MUST BE COMPLETELY COOL WHEN CLEANING. DO NOT SPRAY ANY CLEANER OR LIQUIDS ON THE APPLIANCE WHEN HOT.

The appliance *must* be cleaned as often as once a month (depending on use) to prevent grease build-up and other food deposits.

### INTERIOR

THE **BURNER PORTS** AND **CARRY-OVER PORTS/SLOTS** MUST BE KEPT CLEAN TO ENSURE PROPER IGNITION AND OPERATION.

Remove the burner (see orifice changing instructions) and clean the ports and slots as required. Also inspect and clean the burner inlet for insects and nests. A clogged burner can lead to a fire in the bottom of the appliance.

The inside of the appliance may be cleaned periodically with oven cleaner if desired. Follow the oven cleaner instructions for proper use.

Be careful not to get oven cleaner on the outside surface of the appliance as it can permanently damage the finish.

### EXTERIOR

Stainless steel surfaces when exposed to temperatures produced by the grilling process will change color. The stainless steel will change color from silver to brown and blue. This can be removed by using stainless steel cleaner.

Clean your appliance by first using grill cleaner to remove grease and dirt. Always wipe with the grain (See Fig. 23-1). Next, use stainless steel cleaner to restore the stainless steel color (*Note: not for mirror finish*). Finish by wiping your appliance down using polish wipes. **To clean any mirror finish (if applicable), use a quality brand glass cleaner only, not any of the cleaners mentioned above.**

If your appliance is installed in a seaside (salt air) or poolside (chlorine) location, it will be more susceptible to corrosion and must be maintained/cleaned more frequently. Do not store chemicals (such as chlorine or fertilizer) near your stainless steel appliance.

Due to the nature of stainless steel, surface iron oxide deposits may appear. Do not be alarmed – these deposits are removable with stainless steel cleaner through prompt and periodic maintenance. If not attended to promptly, permanent pitting may occur.

By following these recommendations, you will enjoy the beauty and convenience of your appliance for many years to come.



Fig. 23-1 - Wipe with grain

### PROTECTING YOUR APPLIANCE FROM THE WEATHER

An optional cover will protect your appliance when not in use. (Allow to cool before covering.)

Please specify the model number and serial number of your appliance when ordering a cover.

### IMPORTANT

**IN THE EVENT OF A GREASE FIRE, IMMEDIATELY SHUT OFF THE MAIN GAS VALVE TO THE UNIT. KEEP THE LID OPEN AND ALLOW THE FIRE TO EXTINGUISH ITSELF. A THOROUGH INSPECTION BY A TRAINED SERVICE TECHNICIAN SHOULD BE CONDUCTED BEFORE FUTURE USE OF YOUR UNIT. THE SERVICE TECHNICIAN WILL CHECK THE SYSTEM FOR GAS LEAKS AND WILL CHECK ALL ELECTRICAL WIRING FOR DAMAGE. ALL GAS LEAKS AND WIRING MUST BE REPAIRED PRIOR TO FUTURE USE.**

## CHECKING AND CONVERTING GAS TYPE

This unit comes from the factory configured for one type of gas, as marked on the label located behind the control panel, or on the interior of the unit's enclosure.

**A certified kit is available from the manufacturer to convert your appliance from natural gas to L.P. or vice versa. Contact your dealer for ordering information. The professional installer must reference the steps below for conversion information. If the conversion kit ordered includes instructions, follow those instructions.**

1. Change brass gas orifices (included at original shipping) on each burner to match the new gas type (see MODEL SPECIFICATIONS TABLE, Table 1).
2. If applicable, switch the convertible gas regulator to match the new gas type (see section below).

**Note:** Models to be connected to household propane or natural gas lines require the regulator. For models to be connected to L.P. Cylinders, the regulator is optional.

3. Plumb the unit as appropriate for the new gas supply.
4. Apply the label for the new gas (included at original shipping) over the old gas information found on your unit.

### WARNING

**HAZARDOUS OVERHEATING WILL OCCUR IF A NATURAL-GAS ORIFICE IS USED WITH PROPANE GAS. IF YOU ARE NOT SURE IF THE CORRECT ORIFICES ARE INSTALLED, OR IF AN ORIFICE CHANGE IS NECESSARY, REFER TO THE FOLLOWING INSTRUCTIONS.**

**CAUTION:** Make sure the unit is at a safe temperature and isolated from gas and electrical supplies before beginning the tasks outlined below.

**Note:** The cooler the unit, the greater the tolerances between the stainless-steel parts, and therefore the easier to disassemble and reassemble parts of the unit.

**CAUTION:** For your safety, exercise caution and use adequate hand protection (such as gloves) when handling potentially sharp sheet-metal parts.

## CHECKING AND CONVERTING THE REGULATOR (if applicable)

Regulator: note cap on top

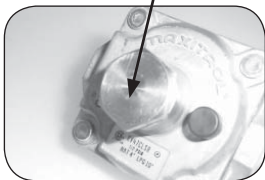

**Note:** Each end of the plastic converter is engraved with either the letters "NAT" or "L.P." (propane) for the respective gasses. When the converter is in the cap and the cap is held uppermost, the letters seen indicate the gas that the regulator is set up for.

To convert the regulator from one gas to another, follow steps 1-4.

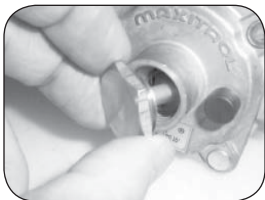

**STEP 1:** Unscrew and remove the cap from the regulator, extracting the converter.



**STEP 3:** Turn the converter around and replace it carefully, into the center of the cap (it will snap into place). Check that you can read the type of gas the unit is set for.



**STEP 2:** Remove the converter (the plastic stalk) by carefully pulling it away from the center of the cap (it will snap out of its seating).

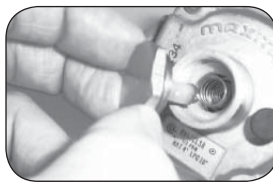

**STEP 4:** Replace the unit into the regulator and screw down until snug.

### WARNING

THIS APPLIANCE REGULATOR IS RATED FOR 1/2 PSI MAXIMUM. IF YOUR GAS SUPPLY IS GREATER THAN 1/2 PSI, AN ADDITIONAL REGULATOR MUST BE INSTALLED TO REDUCE THE INPUT PRESSURE TO THE UNIT TO 1/2 PSI OR LESS. SEE GAS-SUPPLY REQUIREMENTS SECTION FOR PROPER GAS-SUPPLY PRESSURE.

# CHECKING/CONVERTING THE BURNER ORIFICES

## MAIN BURNER ORIFICE SIZE CHECKING/ CONVERSION

Before beginning, make sure you have the proper tools for the task.

This task requires:

- a #2 Phillips-head screwdriver
- a 1/4" nut driver

**Note:** It may be necessary to remove the rotisserie rod before beginning this procedure.

1. Remove cooking grids & vaporizer panels from the barbecue.
2. Locate the burner. Slightly pinch and remove the burner clip (located over the rear center of the burner) from the burner support and set aside. Then carefully lift the burner from the burner support and out from the hole in the forward fire wall (see Fig. 25-1).

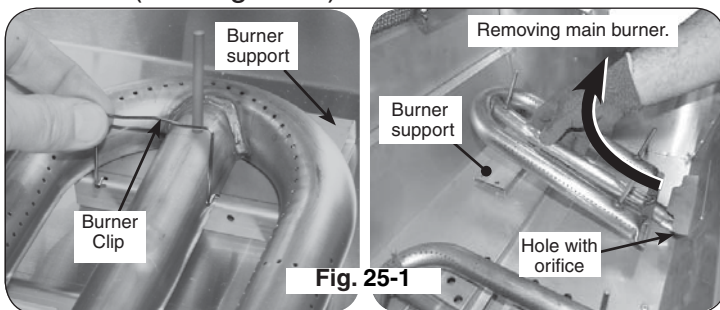

3. Using a 1/2" deep socket nut driver, remove the orifice from the valve. Access this through the hole in the forward firebox plate inside the grill (see PARTS LIST and Fig. 25-1).

Alternatively, the orifice can be accessed through the inside of the control panel. This allows a 1/4" open-end wrench to be used instead of a 1/4" nut driver. To open the control panel, see the CONTROL PANEL REMOVAL section.

4. Check the number stamped on the face of the orifice (see Table 1). Repeat for each burner as necessary.
5. If the barbecue does not have the proper orifices

installed for the gas supply you intend to use, replace them with the correct orifices. Some orifices were supplied with the barbecue. They may also be obtained from the conversion kit or supplied by your local dealer.

**Note: A regulator hose will need to be connected for conversion to propane gas.**

6. After checking the orifice drill size or replacing the orifice, replace the burner over the orifice fitting, sliding it forward, from behind the forward fire wall, so the orifice is centered inside the burner gas inlet, and set it gently onto the burner support. The studs on the bottom back of the burner must each fit through their respective holes in the burner support. This is critical to the safe function of the barbecue. Finally, re-install the burner clip (from step 2) around the burner and into the corresponding holes in the burner support (see Fig. 25-1).
7. Replace the vaporizer panels and the cooking grids. If applicable, reinstall the control panel.

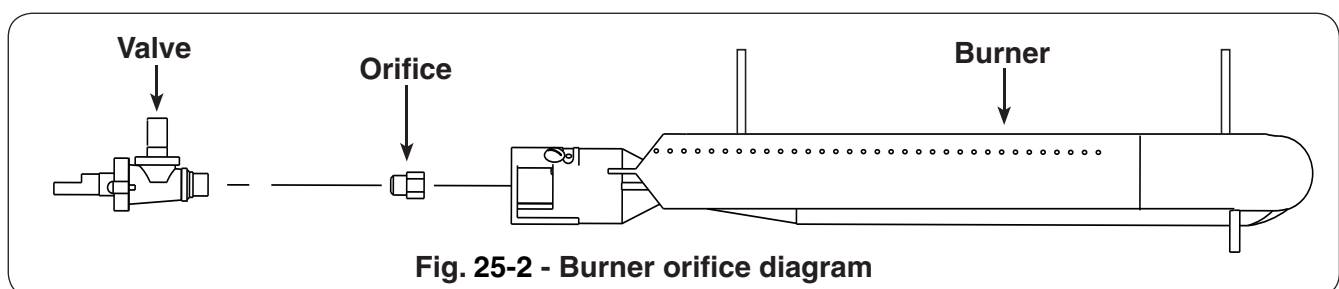

## ADJUSTING YOUR BARBECUE

**Important:** This appliance may not light or heat evenly or cook properly unless the air shutters are adjusted following installation (see AIR SHUTTER ADJUSTMENT section).

Burner air shutters are easily accessed by removing the control panel. See the CONTROL PANEL REMOVAL section for access.

The air shutters are located on the front portion of each burner and have a locking screw that prevents the air shutter from inadvertent movement (see Fig. 26-1).

Remove the cooking grids & vaporizer panels from the barbecue.

To close or open the air shutters, simply loosen the locking screw, using a long stemmed Phillips screwdriver, and turn the air shutter to open or close it. Tighten the screws down when the desired setting is achieved.

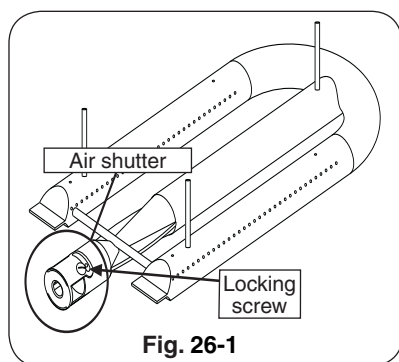

Fig. 26-1

## MAIN BURNER AIR SHUTTER ADJUSTMENT

Light the burner to be adjusted in accordance with the LIGHTING INSTRUCTIONS and burn for 2 minutes with the burner control knob set to **HIGH** and the oven open. After burning for 2 minutes, open the air shutter until the flames lift off, or appear not to be touching the burner. Then begin closing

the air shutter until the flames appear to burn while touching the burner ports (Fig. 26-2). If flames are a lazy yellow, open the air shutters until the flame is mostly blue.

**Note:** Barbecues in some installations achieve a better air/gas mixture and will ignite more quickly if the valve is first turned beyond **HIGH** to **MEDIUM** or **LOW** for lighting.

## BACKBURNER ORIFICE SIZE CHECKING/ CONVERSION (IF EQUIPPED)

Before beginning, make sure you have the proper tools for the task.

This task requires:

- a 1/4" nutdriver
- a 3/8" wrench or socket screwdriver

**Note:** It may be necessary to remove the rotisserie rod before beginning this procedure.

1. Remove the backburner assembly as follows:
  - a. Remove the backburner mounting screws (1/4" hex) located at the left end of the backburner assembly (see Fig. 26-3).
  - b. Carefully pull the left end of the backburner forward until the burner can be moved to the left pulling it free from the orifice located on the right side (see figure on next page).
  - c. Using a 3/8" socket, remove the orifice from the orifice holder and check the number stamped on the face.

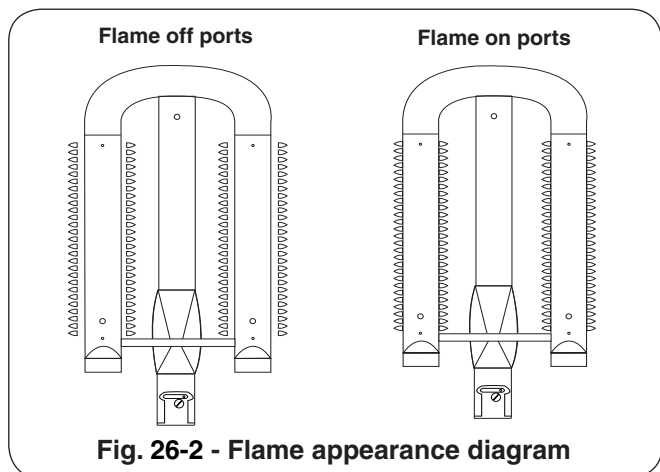

Fig. 26-2 - Flame appearance diagram

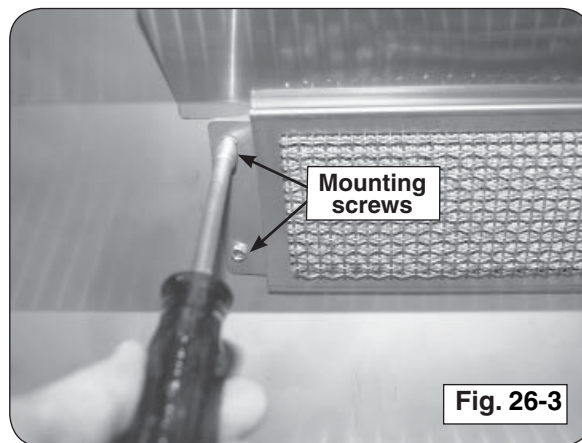

Fig. 26-3

Remove backburner mounting screws.

Procedure continued on next page

## CHECKING/CONVERTING THE BURNER ORIFICES (Cont.)

2. If an orifice change is necessary, replace the orifice with the correctly sized one.
3. Replace the backburner assembly and the electrode by reversing the procedure in steps **a.** through **b.**

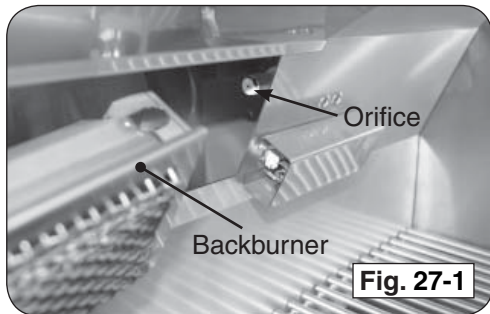

The backburner orifice can be seen on the right side after removing the backburner.

## CONTROL PANEL REMOVAL

To open the control panel:

1. Turn the control knobs to the **OFF** position.
2. Pull the control knobs from their stems and set them aside (A).
3. Using a Phillips screwdriver, unscrew the control panel fastener screws (located on the sides of the control panel). Retain the screws for later re-installation (B).
4. Carefully remove the control panel by lifting and pulling the control panel from the frame (C).

**Important:** During reinstallation; prior to opening the gas shutoff valve, be sure the control knob(s) are in the OFF position.

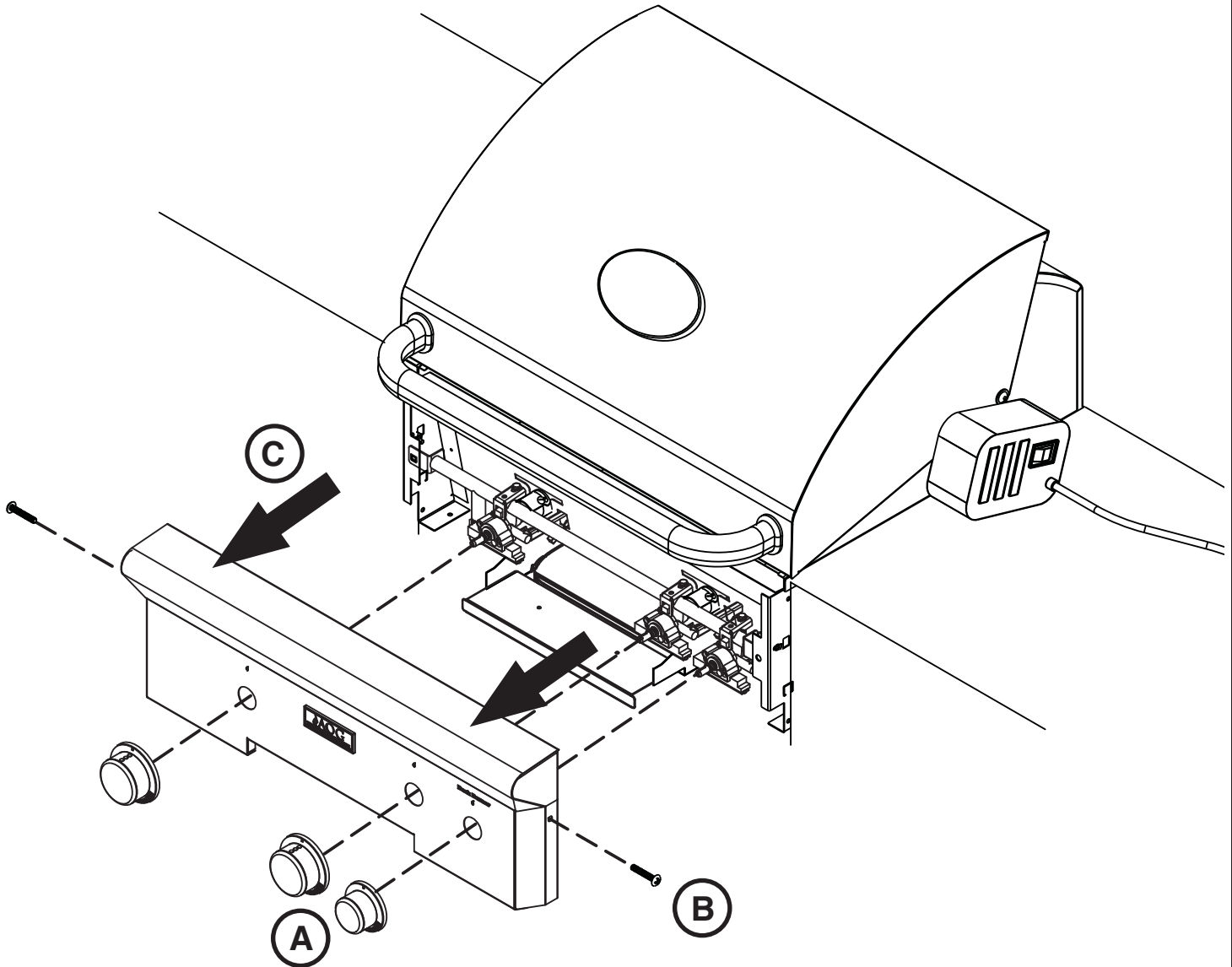

## VALVE "LOW" SETTING ADJUSTMENT

Stability of the "low" setting on main burners and sideburners may vary due to wind direction, grill configuration, and grill position. If your burner goes out when set on low, adjust the valve "low" setting.

**Important:** The valve "low" setting for the backburner must remain at the factory setting. It is recommended to only use the backburner at a medium to high setting.

**To adjust the valve "low" setting:**

1. Ensure the grill is completely cool and the knobs are in the OFF position.
2. Remove the cooking grids, vaporizer panels, control knobs and control panel. See the CONTROL PANEL REMOVAL section for panel removal instructions.
3. Re-install the control knobs on the valve stems with the control panel removed.
4. Light the burner on HIGH, then immediately turn the burner to LOW setting. While the burner is lit, remove the control knob from the valve.
5. Locate the FLATHEAD adjustment screw found above the valve stem and below the manifold (see Fig. 29-1).
6. Using a flathead screwdriver, slowly turn the adjustment screw a little at a time (30° to 45°) in either direction. Adjust the screw as needed until the flame is approximately 1/4" in height from all the burner ports, and the flames are stable.

**CAUTION:** Only adjust the FLATHEAD screw. Adjusting other screws may result in a dangerous gas leak.

7. Once the appropriate setting is reached, re-install the control knob and shut off the burner valve.
8. Repeat this procedure for other main burner valves, if needed.
9. Re-install the control panel, vaporizer panels, and cooking grids.

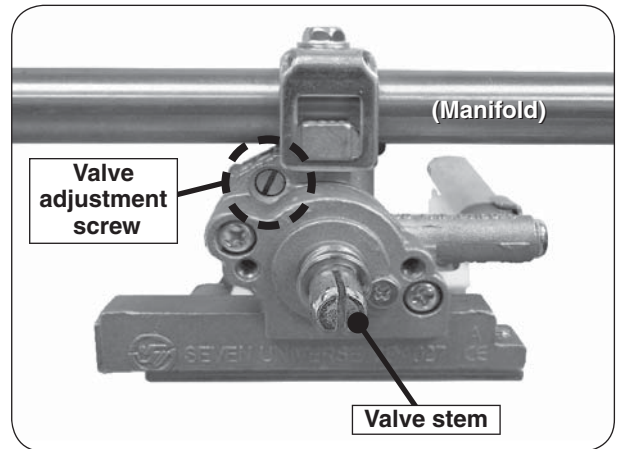

Fig. 29-1 Valve adjustment screw location

## NOTES PAGE

Please use this page to record any information about your unit that you may want to have at hand.

## TROUBLESHOOTING

If you have trouble with the unit, please use this list to identify the problem. By trying one or more of the solutions to the possible cause, you should be able to solve the problem. If this list does not cover your present problem, or if you have other technical difficulties with the unit, please contact your local dealer.

PROBLEM	POSSIBLE CAUSE	CORRECTION
<b>Ignition system failure</b>	1) Improper air shutter adjustment	1) Adjust air shutters.
	2) No spark generated at the valve	2) Retry to light. If ignition failure continues, contact dealer for valve replacement.
	3) Low gas pressure	3) Have the gas co. check supply pressure.
	4) Front carry-over port	4) Clean burner ports.
	5) Ignitor malfunction	5) Contact dealer for replacement.
<b>Insufficient heat / low flame</b>	1) Improper air-shutter adjustment	1) Adjust air shutters.
	2) Using propane orifice for natural gas	2) Check/change orifices.
	3) Low gas pressure/flame (propane)	3) Refill propane tank, or reset propane tank safety*: Shut off all valves (including propane tank) and follow lighting instructions exactly.
	4) Low gas pressure/flame (natural)	4) Have the gas co. check pressure at unit.
	5) L.P. regulator hose cracked due to age	5) Replace L.P. regulator hose.
<b>Uneven heating</b>	1) Burner ports partially blocked by debris	1) Remove burners and clean out ports.
	2) Small spiders or insects in burner	2) Inspect burners and orifices for spider webs or other debris that may block flow.
	3) Improper air shutter adjustment	3) Adjust air shutter.
<b>Rotisserie noisy</b>	1) Rotisserie out of balance	1) Adjust rotisserie counterbalance.
<b>Burner goes out on LOW</b>	1) Valve "Low" setting needs adjustment	1) See the VALVE "LOW" SETTING ADJUSTMENT section for details.

**Table 2**

**Note:** \*Propane tanks are equipped with a safety shutdown device that may cause low or no gas/flame at the burners if operating and lighting instructions are not followed exactly. If you suspect the propane tank safety shutoff is in effect, shut off all burner control valves and the propane tank valve. Then read and follow the LIGHTING INSTRUCTIONS exactly. Lighting instructions are located in the owner's manual. If the problem persists, continue troubleshooting, or contact your local dealer or distributor for assistance.

# WARRANTY

## AMERICAN OUTDOOR GRILL LIMITED WARRANTY

American Outdoor Grill warrants your grill to be free from defects in material and workmanship.

American Outdoor Grill stainless-steel burners are warranted for **FIFTEEN (15) YEARS**. All other American Outdoor Grill parts are warranted for **TEN (10) YEARS**. (Except as noted below.)

American Outdoor Grill infrared burners and vaporizer panels are warranted for **THREE (3) YEARS**.

American Outdoor Grill ignition systems (excluding batteries) and accessories (including sideburners, motors, and thermometers) are warranted for **ONE (1) YEAR**.

### A COPY OF YOUR SALES SLIP FOR PROOF OF PURCHASE IS REQUIRED

This warranty applies to the original purchaser for products which are installed in the United States or Canada and which are operated and maintained as intended for single family residential usage. This warranty is valid only with proof of purchase, shall commence on the date of purchase, and shall terminate (both as to original and any replacement products) on the anniversary date of the original purchase of the product stated on the above schedules.

This warranty covers defects in material and workmanship. This warranty **does not** cover parts which become defective as a result of negligence, misuse, use not in compliance with the Owner's Manual/Installation Instructions, accidental damage, improper handling, improper storage, improper installation, lack of required routine maintenance (as specified in the Owner's Manual/Installation Instructions), electrical damage, local gas impurities or failure to protect against combustibles. Product must be installed (and gas must be connected) as specified in the Owner's Manual/Installation Instructions by a **qualified professional installer**. Modifications to products which are not specifically authorized will void this warranty. Accessories, parts, valves, remotes, etc. when used must be Peterson products or this warranty is void. Warrantied items will be repaired or replaced at Peterson's sole discretion. This warranty **does not** apply to rust, corrosion, oxidation, or discoloration unless the affected part becomes inoperable.

This warranty **does not** cover labor or labor related charges, except as provided by separate specific written programs from the Peterson Co. All repair work must be performed by a qualified professional service person and requires prior approval of Peterson.

Peterson may require the defective product or part to be returned to the factory to determine the cause of failure. Peterson will pay freight charges if the product or part is determined to be defective. This warranty does not cover breakage in shipment from our (Independent) distributor to its customer if the damage is determined to have occurred during that shipment.

This warranty specifically excludes liability for **indirect, incidental, or consequential** damages. Some states and provinces do not allow the exclusion or limitation of incidental or consequential damages, so the above exclusion may not apply to you. This warranty gives you specified legal rights, and you may have other rights that vary from state to state or province.

For additional information regarding this warranty, or to place a warranty claim, contact the R. H. Peterson dealer where the product was purchased.

**TO REGISTER YOUR PRODUCT ONLINE GO TO: [WWW.AMERICANOUTDOORGRILL.COM](http://WWW.AMERICANOUTDOORGRILL.COM), AND CLICK ON PRODUCT REGISTRATION. THANK YOU FOR YOUR PURCHASE.**

<b>Quality Check</b>			<b>Date:</b> _____		
<b>Burner Orifices</b>	Nat. _____	L.P. _____	<b>Leak Test:</b> _____	<b>Model#:</b> _____	
<b>Main:</b>	_____	_____	<b>Burn Test:</b> _____	<b>Serial#:</b> _____	
<b>Back:</b>	_____	_____	<b>Gas Type:</b> <u>Nat. / L.P.</u>	<b>Air Shutter:</b> _____	
<b>Side/Power:</b>	_____	_____		<b>Inspector:</b> _____	
<b>Infrared:</b>	_____	_____			
<b>Other:</b>	_____	_____			