

# ACR1011W



53.13" x 23.38" x 27.75" (H x W x D)

Upright healthcare all-refrigerator with self-closing solid door, front lock, digital controls, and external temperature readout

### Highlights:

Designed and constructed for reliable cold storage in healthcare facilities

Factory installed lock provides security you can count on

External temperature readout of the current and high/low temperatures

### Product Features:

EQTemp Medical Refrigerator	All-refrigerator designed to operate between 2 and 8°C for a variety of storage application in medical offices and other healthcare facilities
Temperature Range: 2° to 8°C	Preset to 5°C as recommended for many storage applications
Large capacity	Full 9.88 cu.ft. capacity inside conveniently slim footprint
External temperature readout	Includes continuous display of the current interior and high/low temperature, and can be switched from Celsius to Fahrenheit at the touch of a button
High/low temperature alarm	Audible alarm sounds if the interior temperature rises or falls out of set range
Buffered temperature probe	Thermometer probe is encased in a glass bead-filled bottle and stored in a fixed box on the center shelf. This is the ideal way to produce temperature readings closest to stored contents, as recommended by the CDC and VFC's guidelines
Access port	3/8" probe hole with cover is pre-installed in unit's side to allow easy installation of user-provided monitoring equipment
Factory installed lock	Keyed lock for a secure interior (2 keys included)
Automatic defrost	Reduced user maintenance with automatic defrost

## ACR1011W Specifications:

Overview	
Nominal Width	24.0" (61 cm)
Nominal Depth	28.0" (71 cm)
Nominal Height	54.0" (137 cm)
Height of Cabinet	53.13" (135 cm)
Width	23.38" (59 cm)
Width with Door Open	23.88" (61 cm)
Depth	27.75" (70 cm)
Depth with door at 90°	45.25" (115 cm)
Capacity	9.88 cu.ft. (280 L)
Defrost Type	Automatic
Door	White
Cabinet	White
US Electrical Safety	ETL
Canadian Electrical Safety	ETL-C
Amps	2.0
Voltage/Frequency	115 V AC/60 Hz
Weight	116.8 lbs. (53 kg)
Parts & Labor Warranty	1 Year
Compressor Warranty	5 Years
UPC	761101082950
Refrigerator Features	
Door Swing	RHD
Reversible	Factory Reversible
Shelf Type	Wire
Shelf Qty	4
Adjustable Shelves	Yes
Thermostat Type	Digital
Fan Type	Interior
Refrigerant Type	R600a
Refrigerant Amount	2.0oz.
High Side PSI	1.45
Low Side PSI	0.85
Level Legs Qty	2
Interior Light	Yes
Temperature Range	2° to 8°C
Sound Level	37.7 dB
Dimensions	

Interior Height	44.63" (113 cm)
Interior Width	20.0" (51 cm)
Interior Depth	21.5" (55 cm)
Compressor Step Height	9.0" (23 cm)
Compressor Step Width	20.0" (51 cm)
Compressor Step Depth	8.0" (20 cm)

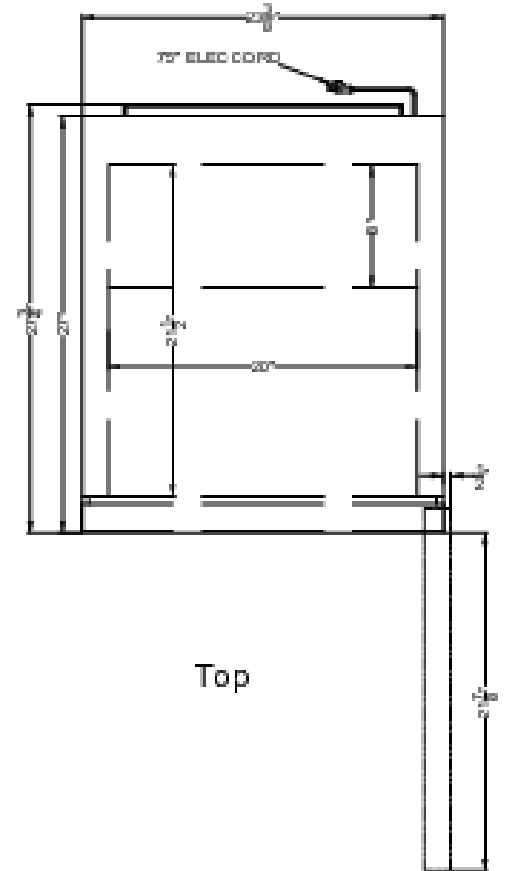

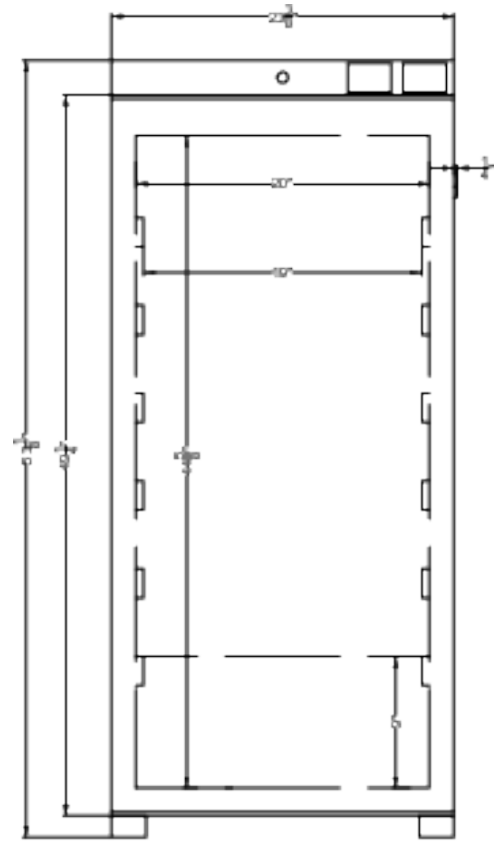

Front