

## BLUESTAR INDOOR CHARBROILER

With over 125 years of experience making cooking equipment, and as the leading manufacturer of high-performance commercial-style ranges for the home, it is no surprise that BLUESTAR makes the finest residential indoor charbroiler available. With 15,000 BTUs of power and adjustable grate positioning for variable temperature cooking, our Indoor Charbroiler is an unsurpassed addition to every cook's favorite room in the house. Heavy-duty construction combined with innovative features produce an appliance of uncompromising durability, functionality, and beauty that will be enjoyed for years to come!



*Model PRZIDCB30  
30" Indoor Charbroiler*

### BlueStar Charbroiler Series (15" and 30")

- Heavy-duty, commercial stainless steel construction.
- Two, powerful 15,000 BTU burners on 30" model. 15" model features one 15,000 BTU burner.
- Adjustable grate positioning for variable temperature cooking.
- Cast iron, easy clean grates.



*30" Indoor Charbroiler with optional griddle*

### Commercial U-Burners

The key to perfect grilling is intense, even heat. And no other grill can compare with BlueStar's unique stainless steel U-burner, which produces extremely high, consistent heat across the entire burner surface. Combined with BlueStar's stainless steel flavor savor, the charbroiler cooking system will provide years of cooking enjoyment.

### Cast-Iron Grates

Our matte-porcelain, cast-iron grates are an important part of the cooking process. Once heated, they provide heat retention and even temperature distribution to ensure an even cooking surface. The reversible grates provide an ideal cooking surface for steaks and fish, leaving a professional sear-pattern appearance.

# BLUESTAR INDOOR CHARBROILER

## Standard Features

- Heavy-duty, commercial stainless steel construction.
- Stainless steel commercial U-burners.
- Push-to-turn, burner controls.
- Heavy-duty control knobs.
- Removable drip trays with steel roller bearings.
- Wrap-around splash guard.
- 1 year parts and labor warranty.

## BlueStar Indoor Charbroiler Configurations

MODEL PRZIDCB30

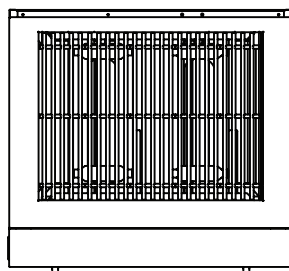

WITH OPTIONAL GRIDDLE

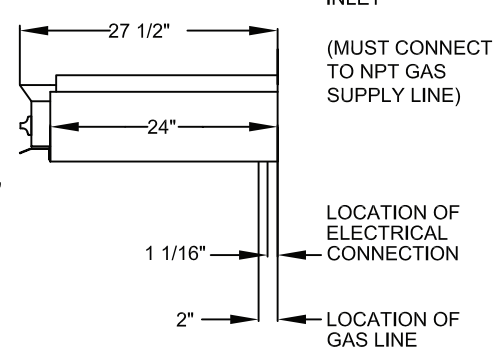
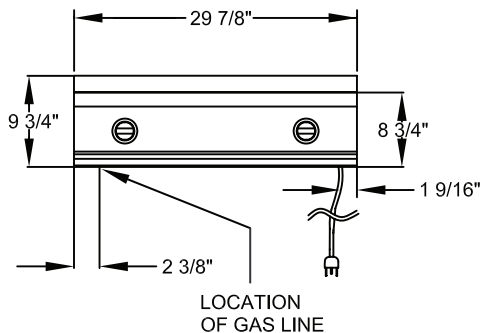
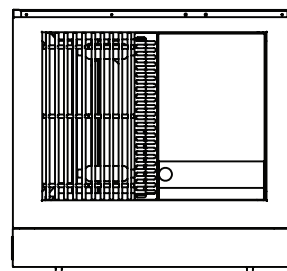

1/2" NPT  
BOTTOM GAS  
INLET

(MUST CONNECT  
TO NPT GAS  
SUPPLY LINE)

LOCATION OF  
ELECTRICAL  
CONNECTION

LOCATION OF  
GAS LINE

Top burner rating..... 15,000 BTU  
Top power burner rating..... 15,000 BTU  
Grill burner rating..... 15,000 BTU  
Griddle burner rating (optional)... 15,000 BTU  
Simmer burner rating..... 130° F

Electrical requirements..... 120 VAC, 9 Amps  
single phase

Operating gas pressure..... NAT: 5.0" WC  
LP: 10.0" WC

Installation clearance..... 0" side cabinet  
0" back wall

*\*\* All specifications are subject to change  
without prior notification.*

## BlueStar Indoor Charbroiler Backguard Options

### Island Trim Back

Allows flush-mounting into an island. Oven vents through top of back.

*(Available on 30" Model only)*



### 8" Low Profile Back

Protects the back wall while allowing for custom treatment.

*(Standard on 15" Model;  
Available on 30" Model)*



### 17" Backguard *(not shown)*

*(Available on 30" Model only)*

### 21" High Shelf

Produces a true gourmet professional look while providing a convenient holding area for plates and prepared food.

*(Available on 30" Model only)*



## Accessories

Cutting Boards            Casters  
Charbroiler Covers        Wok Ring  
Rotisserie Kit (30" only)

## Additional Products

Cooktops                    Hoods  
Barbecue Grills            Warming Drawers  
Salamander Broiler        Free Standing Ranges

## Dealer



Manufacturing Facility:  
600 Arlington Street, Reading, PA USA 19611  
www.bluestarcooking.com



0507-01-RevA