

BLUESTAR 30" RCS SERIES

With over 125 years of experience making cooking equipment, and as the leading manufacturer of high-performance commercial-style ranges for the home, it is no surprise that BLUESTAR makes the finest residential ranges available. The unparalleled accuracy of gas surface cooking and the versatility found in the baking and roasting qualities of our oven makes this an unsurpassed addition to every cook's favorite room in the house.

Heavy-duty construction combined with innovative features produce an appliance of uncompromising durability, functionality, and beauty that will be the focal point of your kitchen for years to come!

BlueStar 30" RCS Series

- Largest oven capacity available on a 30" range.
- Accommodates a full-size commercial 18" x 26" baking sheet.
- 24" depth for compatibility with standard kitchen cabinetry.

Model RCS304BSS shown at right.



NOVA™, SUPERNOVA™ and Simmer Burners

Our cast iron porcelain-enameled NOVA™ and SUPERNOVA™ top burners are the most versatile burners in the industry. The Nova burner provides up to 15,000 BTU's of cooking power. For that extra boost, the SUPERNOVA™ delivers an amazing 18,000 BTU's; a rapid boil or superior sauté is never a problem! When using our gentle 130°F simmer feature, delicate sauces and soups are made simple with superior temperature control and flame disbursement.



Oven Capacity

The cavity design of the oven provides the most precise temperature control, which delivers even heat distribution resulting in versatile performance. It has the largest oven capacity available on a 30" range and will accommodate a full-size commercial 18" x 26" baking sheet.



Infrared Broiler

Because of its popularity in the commercial market, the direct-fired ceramic infrared broiler is standard on all residential ranges. The large burner produces 1850°F of intense, searing heat close to the burner, while effecting a gentler broiling for foods placed farther away. The broiler is fully recessed into the oven's top to create maximum cooking space.



Full Motion Grates

Bring sauce to a boil while stirring on a front burner, then slide it to the rear to simmer while you sauté up front! Our full motion grates allow you to easily reposition pots and pans from front to rear burners without lifting. The grates are also oversized to accommodate the largest stock pots and sauté pans.

BLUESTAR 30" RCS SERIES

Standard Features

- Heavy-duty, commercial stainless steel construction.
- Automatic electronic ignition and re-ignition system.
- Interior oven light.
- Island Trim (for use in an island installation only)
- Ceramic infra-red broiler.
- Commercial quality oven control.
- Heavy-duty oven door.
- Push-to-turn, infinite setting NOVA™ and SUPERNOVA™ top burner controls with new 130°F simmer burner.
- Heavy-duty control knobs.
- Removable drip trays with steel roller bearings.
- Extra large oven capacity. Large oven: 26.25"W x 20"D x 15"H.
- 1 year parts and labor warranty.

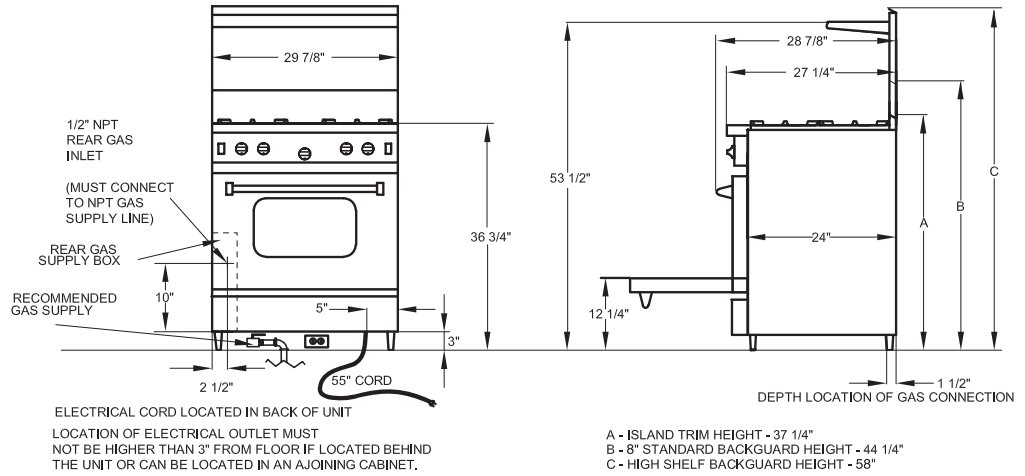

Top Burner Rating	15,000 BTU	Simmer Burner Rating	9,000 BTU, 130°F
Top Power Burner Rating	18,000 BTU	Electrical Requirements	120 VAC, 15 Amps (Unit must be on a non-GFI, dedicated outlet) Single Phase
Infrared Broiler Rating	15,000 BTU	Operating Gas Pressure	NAT: 5.0" WC LP: 10.0" WC
Oven Burner Rating	30,000 BTU	Installation Clearance	0" Side Cabinet 0" Back Wall 3" Top Cabinet Per Side

** All specifications are subject to change without prior notification.

BlueStar Backguard Options

Island Trim Back

Allows flush-mounting into an island. Oven vents through top of back. (Shown on 36" Model)

8" Low Profile Back

Protects the back wall while allowing for custom treatment. (Shown on 30" Model)

21" High Shelf

Produces a true gourmet professional look while providing a convenient holding area for plates and prepared food. (Shown on 36" Model)



BlueStar 30" RCS Configuration

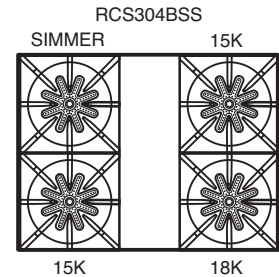

Dealer

Accessories

- Casters
- Wok Ring

Additional Products

- Cooktops
- Barbecue Grills
- Indoor Charbroilers
- Hoods
- Warming Drawers
- Salamander Broiler



Manufacturing Facility:
600 Arlington Street, Reading, PA USA 19611
www.bluestarcooking.com



0107-03-RevC