

New features found only on the Platinum Series offer unsurpassed power and performance for discerning home chefs who demand restaurant-quality results.

### PRODUCT FEATURES

- PrimaNova™ power burner delivers 25,000 BTUs of intense heat
- All burners including Interchangeable Griddle and Charbroiler
- Gentle 130° simmer burner
- New PowR Oven™ provides 40% faster preheating and 30% increase in oven efficiency
- Extra-large oven with True European Convection 1850° Infrared Broiler
- Accommodates full-size commercial 18" x 26" baking sheet
- Available in 750+ colors and finishes

### SPECIFICATIONS

Range Dimensions: 47.875"W x 24"D x 36.75"H

Oven Interior: 26.25"W x 20"D x 15"H

Top Burner Rating: 25,000 BTUs

Simmer Burner Rating: 9,000 BTUs

PowR Oven™ Burner Rating: 25,000 BTUs

Infrared Broiler Rating: 15,000 BTUs

Electrical Requirements: 120V, 60Hz, 15 AMPs, 1 PH  
(Unit must be on a Non-GFI, dedicated outlet)

Operating Gas Pressure: NAT: 5.0" WC, LP: 10.0" WC

Gas Line Size: 3/4"

Installation Clearance: 0" Side Cabinet, 0" Back Wall



### MODEL CONFIGURATION

Eight Burners with Interchangeable Griddle Charbroiler **BSP488B**

### BURNER CONFIGURATION

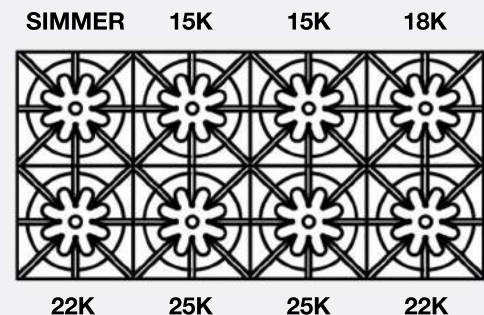

### ADDITIONAL CUSTOMIZATION OPTIONS

- Burner configurations
- Backguards
- Knob colors
- Trim options

*All specifications subject to change without notice. Contact BlueStar Customer Service at (800) 449 - 8691 prior to installation or site preparation.*

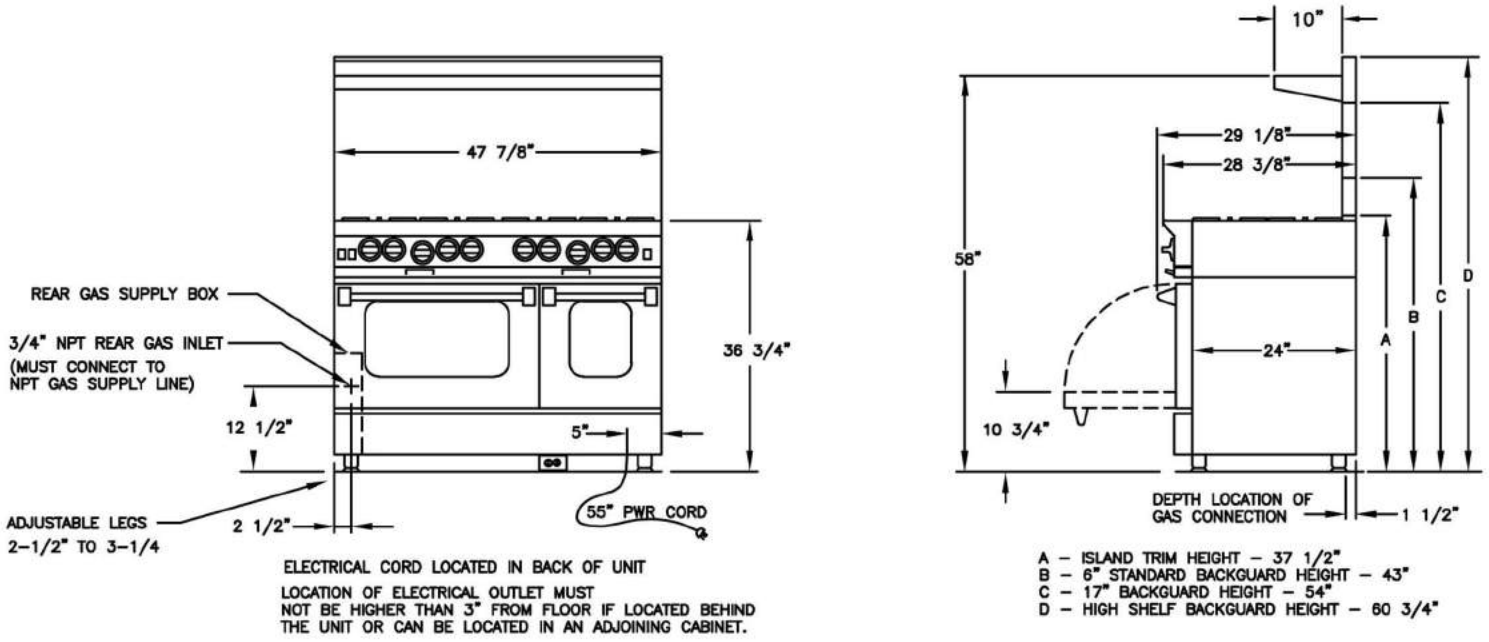

## RELATED PRODUCTS

### VENTILATION



### SALAMANDER BROILER

