

2019

Premium domestic range hoods

FORTÉ[®]
M I L A N O

ALBERTO RANGE HOOD 30 - 36 inches

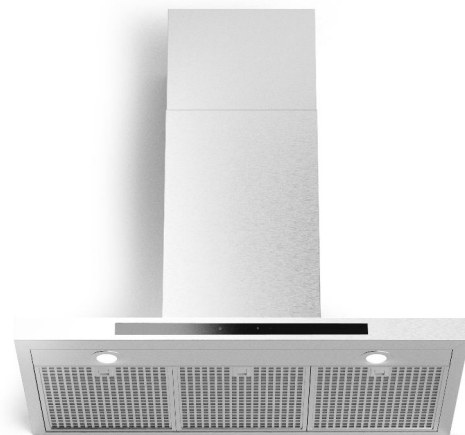
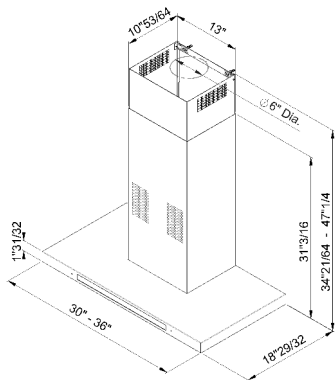

ALBERTO

ALBERTO 30 - 36 inches

FEATURES

- Premium domestic range hood
- Stainless-steel construction
- Welded seams
- Hand-finished edges
- Heavy-duty blower
- Stainless-steel design filters dishwasher safe
- Time delay shut-off
- Light indicator for grease filter maintenance
- Light indicator for charcoal filter replacement
- Convertible (external venting or recirculating)
- Easy installation system
- Made in Italy

SPECS

- Motor capacity: 560 CFM
- Controls: Touch control
- Lights: 2 X LED
- ETL approved

ACCESSORIES

- Recirculation kit (not included)



PRODUCT PLUS

The ALBERTO is a box-design chimney hood in stainless steel. Change the desired extraction power level settings or turn the LED lights on or off with elegant glass touch-controls. An impressive extraction rate will have your kitchen odour free in no time. LED hood lighting illuminate your kitchen and helps you keep an eye on your cooking.

Light indicator for grease filter maintenance

The cooker hood automatically informs you when the metal grease filter designed for trapping grease in the air requires cleaning. It is of utmost importance to clean these filters to ensure cooker hood components are protected and to pre-vent bad odours caused by a build-up of grease.

Light indicator for charcoal filter substitution

The cooker hood automatically informs you when the active carbon filter requires replacing. This filter is designed to absorb odours produced when cooking. It is of utmost importance to replace these filters regularly as they lose their efficiency and odour trapping performance.

Time delay shut-off

This function allows you to programme delayed cooker hood shutdown which, in the shortest time possible, provides the right level of air purity in your kitchen.

BELLINA RANGE HOOD 30 - 36 inches

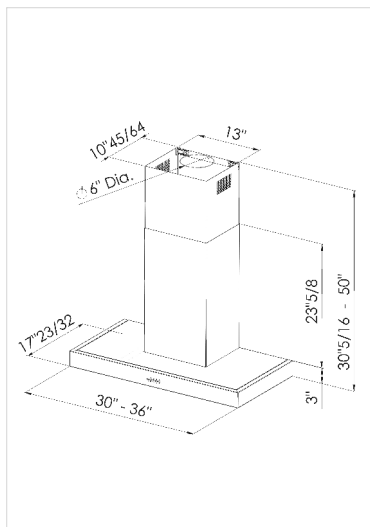

BELLINA

BELLINA 30 - 36 inches

FEATURES

- Premium domestic range hood
- Stainless-steel construction
- Welded seams
- Hand-finished edges
- Heavy-duty blower
- Stainless-steel design filters dishwasher safe
- Time delay shut-off
- Light indicator for grease filter maintenance
- Light indicator for charcoal filter replacement
- Convertible (external venting or recirculating)
- Easy installation system
- Made in Italy

SPECS

- Motor capacity: 560 CFM
- Controls: Electronic push buttons soft touch
- Lights: 2 X LED
- ETL approved

ACCESSORIES

- Recirculation kit (not included)



PRODUCT PLUS

Featuring a traditional T-shape design finished in stainless steel, the **BELLINA Chimney Cooker Hood** is sure to complement any kitchen while clearing your cooking space of fumes and odours.

Low maintenance and energy efficient LED lighting provides an illuminated view of your dish, as well as a warm, ambient atmosphere in your kitchen.

Light indicator for grease filter maintenance

The cooker hood automatically informs you when the metal grease filter designed for trapping grease in the air requires cleaning. It is of utmost importance to clean these filters to ensure cooker hood components are protected and to pre-vent bad odours caused by a build-up of grease.

Light indicator for charcoal filter substitution

The cooker hood automatically informs you when the active carbon filter requires replacing. This filter is designed to absorb odours produced when cooking. It is of utmost importance to replace these filters regularly as they lose their efficiency and odour trapping performance.

Time delay shut-off

This function allows you to programme delayed cooker hood shutdown which, in the shortest time possible, provides the right level of air purity in your kitchen.

BRAVO RANGE HOOD 30 - 36 inches

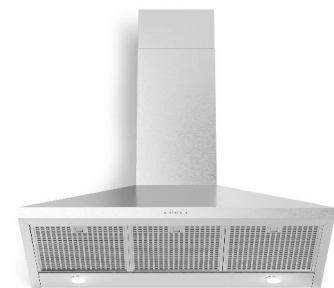
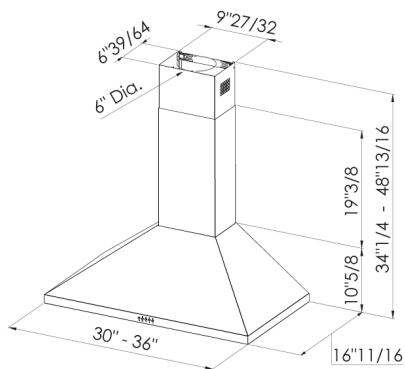
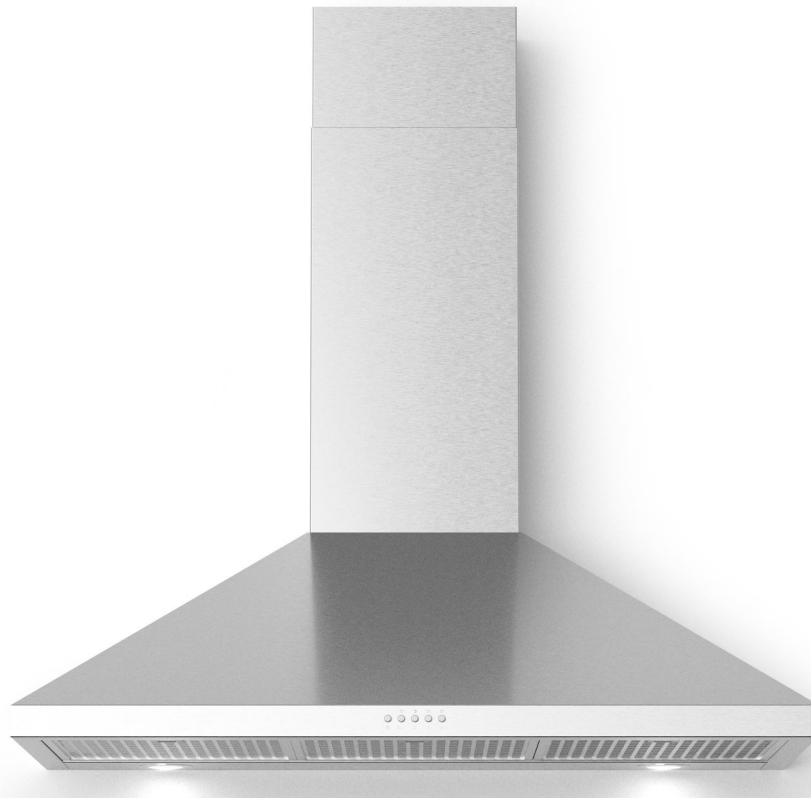

BRAVO RANGE HOOD

BRAVO 30 - 36 inches

FEATURES

- Premium domestic range hood
- Stainless-steel construction
- Welded seams
- Hand-finished edges
- Heavy-duty blower
- Stainless-steel design filters dishwasher safe
- Time delay shut-off
- Light indicator for grease filter maintenance
- Light indicator for charcoal filter replacement
- Convertible (external venting or recirculating)
- Easy installation system
- Made in Italy

SPECS

- Motor capacity: 560 CFM
- Controls: Electronic push buttons soft touch
- Lights: 2 X LED
- ETL approved

ACCESSORIES

- Recirculation kit (not included)



PRODUCT PLUS

Combining classic design with powerful extraction, the BRAVO Chimney Cooker Hood from Forté Milano will help you keep a fresh kitchen, while bringing a sophisticated and streamlined look to your decor.

The BRAVO Cooker Hood delivers 4 different stages of extraction to allow you to tailor the power of your hood as needed, leaving your kitchen clear and odour-free. It uses washable design stainless-steel filters that capture oil and dust from the air, and can be easily washed by hand or in a dishwasher for added convenience.

The LED lighting in the hood provides improved visibility and ambient lighting while you are cooking, as well as low energy consumption. It has both re-circulation or extraction options, and is designed for wall mounting between furniture or as a stand-alone unit.

Light indicator for grease filter maintenance

The cooker hood automatically informs you when the metal grease filter designed for trapping grease in the air requires cleaning. It is of utmost importance to clean these filters to ensure cooker hood components are protected and to pre-vent bad odours caused by a build-up of grease.

Light indicator for charcoal filter substitution

The cooker hood automatically informs you when the active carbon filter requires replacing. This filter is designed to absorb odours produced when cooking. It is of utmost importance to replace these filters regularly as they lose their efficiency and odour trapping performance.

Time delay shut-off

This function allows you to programme delayed cooker hood shutdown which, in the shortest time possible, provides the right level of air purity in your kitchen.

COLLEGARE Connectivity Chimney Range Hood



FORTÉ[®]
M I L A N O

COLLEGARE Connectivity Chimney Range Hood

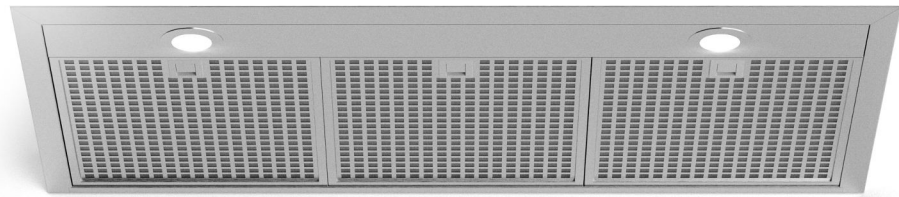
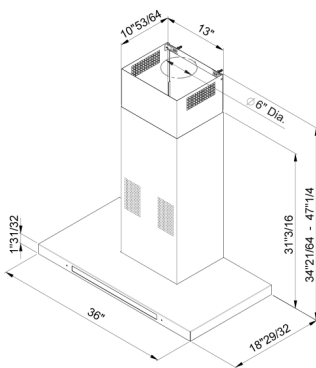

COLLEGARE

COLLEGARE 36 inches

FEATURES

- Premium domestic range hood
- Stainless-steel construction
- Welded seams
- Hand-finished edges
- Heavy-duty blower
- Stainless steel design filters dishwasher safe
- Wireless loudspeakers with Bluetooth technology
- Integrated digital radio
- Integrated microphone for handfree telephone call / answer
- Second microphone to reduce environmental interference
- Light indicator for grease filter maintenance
- Light indicator for charcoal filter replacement
- Time delay shut-off
- Convertible (external venting or recirculating)
- Easy installation system
- Made in Italy

SPECS

- Motor capacity: 560 CFM
- Controls: Touch screen
- Lights: 2 X LED

ACCESSORIES

- Recirculation kit (not included)



PRODUCT PLUS

Crafted from stainless steel with a sleek black glass touch panel and two LED lights, this multi-functional cooker hood will revolutionise your kitchen. Featuring smart phone connectivity and an integrated digital radio, you can listen to music on your smartphone through the built-in speakers. For added convenience you can use the one-touch function to quickly answer phone calls, and talk handsfree without the need to pick up your phone.

Light indicator for grease filter maintenance

The cooker hood automatically informs you when the metal grease filter designed for trapping grease in the air requires cleaning. It is of utmost importance to clean these filters to ensure cooker hood components are protected and to pre-vent bad odours caused by a build-up of grease.

Light indicator for charcoal filter substitution

The cooker hood automatically informs you when the active carbon filter requires replacing. This filter is designed to absorb odours produced when cooking. It is of utmost importance to replace these filters regularly as they lose their efficiency and odour trapping performance.

Adjustable and delayed self-switching off

This function allows you to programme delayed cooker hood shutdown which, in the shortest time possible, provides the right level of air purity in your kitchen.

CORTIVO ISLAND RANGE HOOD 36 inches

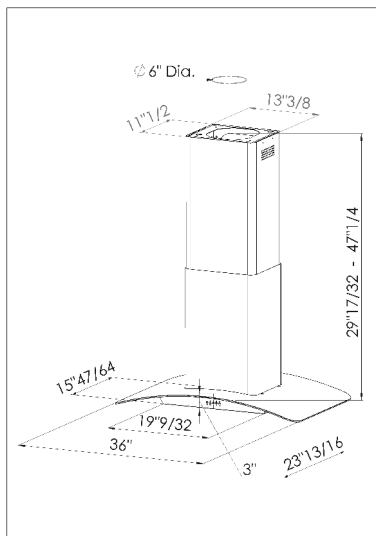

CORTIVO ISLAND

CORTIVO ISLAND 36 inches

FEATURES

- Premium domestic range hood
- Glass & Stainless-steel construction Welded seams
- Hand-finished edges
- Heavy-duty blower
- Stainless-steel design filters dishwasher safe
- Time delay shut-off
- Light indicator for grease filter maintenance
- Light indicator for charcoal filter replacement
- Convertible (external venting or recirculating)
- Easy installation system
- Made in Italy

SPECS

- Motor capacity: 560 CFM
- Controls: Electronic push buttons soft touch
- Lights: 4 X LED
- ETL approved

ACCESSORIES

- Recirculation kit (not included)



PRODUCT PLUS

The CORTIVO is an impressive ceiling-mounted, stainless steel, island chimney hood with glass canopy, ideal for all kitchen islands. The powerful extraction rate quickly takes away those unwanted odours and fumes, leaving your kitchen air fresh and clear.

For a better overview when cooking, the energy-saving LED lights supply more light from above on your hob.

Soft touch button control makes controlling the extractor speeds and lighting easy. This unit also features height adjustable chimney sections, a design grease filter and grease and charcoal filter maintenance indicators.

Light indicator for grease filter maintenance

The cooker hood automatically informs you when the metal grease filter designed for trapping grease in the air requires cleaning. It is of utmost importance to clean these filters to ensure cooker hood components are protected and to pre-vent bad odours caused by a build-up of grease.

Light indicator for charcoal filter substitution

The cooker hood automatically informs you when the active carbon filter requires replacing. This filter is designed to absorb odours produced when cooking. It is of utmost importance to replace these filters regularly as they lose their efficiency and odour trapping performance.

Time delay shut-off

This function allows you to programme delayed cooker hood shutdown which, in the shortest time possible, provides the right level of air purity in your kitchen.

CORTIVO WALL RANGE HOOD 30 - 36 inches

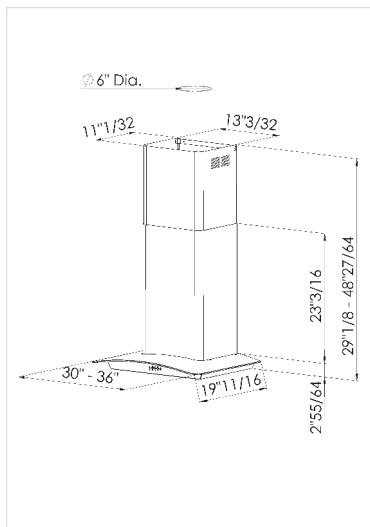

CORTIVO

CORTIVO 30 - 36 inches

FEATURES

- Premium domestic range hood
- Glass & Stainless-steel construction Welded seams
- Hand-finished edges
- Heavy-duty blower
- Stainless-steel design filters dishwasher safe
- Time delay shut-off
- Light indicator for grease filter maintenance
- Light indicator for charcoal filter replacement
- Convertible (external venting or recirculating)
- Easy installation system
- Made in Italy

SPECS

- Motor capacity: 560 CFM
- Controls: Electronic push buttons soft touch
- Lights: 2 X LED
- ETL approved

ACCESSORIES

- Recirculation kit (not included)



PRODUCT PLUS

Combining style and functionality, the **CORTIVO Chimney Cooker Hood** eliminates unwanted fumes and odours, leaving you with a clear and welcoming cooking space.

The **CORTIVO** offers 4 different stages of extraction power which can be effortlessly selected using the modern soft touch controls.

Low maintenance and energy efficient **LED lighting** provides an illuminated view of your dish, as well as a warm, ambient atmosphere in your kitchen.

Light indicator for grease filter maintenance

The cooker hood automatically informs you when the metal grease filter designed for trapping grease in the air requires cleaning. It is of utmost importance to clean these filters to ensure cooker hood components are protected and to pre-vent bad odours caused by a build-up of grease.

Light indicator for charcoal filter substitution

The cooker hood automatically informs you when the active carbon filter requires replacing. This filter is designed to absorb odours produced when cooking. It is of utmost importance to replace these filters regularly as they lose their efficiency and odour trapping performance.

Time delay shut-off

This function allows you to programme delayed cooker hood shutdown which, in the shortest time possible, provides the right level of air purity in your kitchen.

LIBERTA RANGE HOOD 28 - 34 inches

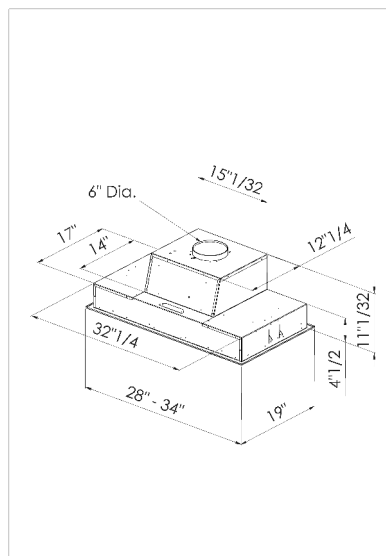

LIBERTA

LIBERTA 28 - 34 inches

FEATURES

- Premium domestic range hood
- Stainless-steel construction
- Welded seams
- Hand-finished edges
- Heavy-duty blower
- Stainless steel baffle anti-grease filters dishwasher safe
- Time delay shut-off
- Light indicator for grease filter maintenance
- Light indicator for charcoal filter replacement
- Convertible (external venting or recirculating)
- Easy installation system
- Made in Italy

SPECS

- Motor capacity: 560 CFM
- Controls: Electronic push buttons soft touch 4 speeds
- Lights: 2 X LED
- ETL approved

ACCESSORIES

- Recirculation kit (not included)



PRODUCT PLUS

The LIBERTA Cooker Hood is designed to be discreet and efficient, and comes in stylish stainless steel to keep your kitchen odour free. Thanks to a powerful motor, this cooker hood will clear your kitchen of cooking fumes quickly and efficiently. The full range of the hood's functions are consolidated into a single electronic control, meaning settings can be monitored and adjusted with just one touch. It also features two LED lights to illuminate your cooking.

Baffle stainless steel anti-grease filters & grease collector

Baffle filters effectively capture grease and are dishwasher safe making it easier to have a clean and odor-free kitchen. The grease captured by the filters drains into the removable dishwasher safe grease collector.

Light indicator for grease filter maintenance

The cooker hood automatically informs you when the metal grease filter designed for trapping grease in the air requires cleaning. It is of utmost importance to clean these filters to ensure cooker hood components are protected and to pre-vent bad odours caused by a build-up of grease.

Light indicator for charcoal filter substitution

The cooker hood automatically informs you when the active carbon filter requires replacing. This filter is designed to absorb odours produced when cooking. It is of utmost im-portance to replace these filters regularly as they lose their efficiency and odour trapping performance.

Time delay shut-off

This function allows you to programme delayed cooker hood shutdown which, in the shortest time possible, provi-des the right level of air purity in your kitchen.

LUCCA RANGE HOOD 30-36-40 inches

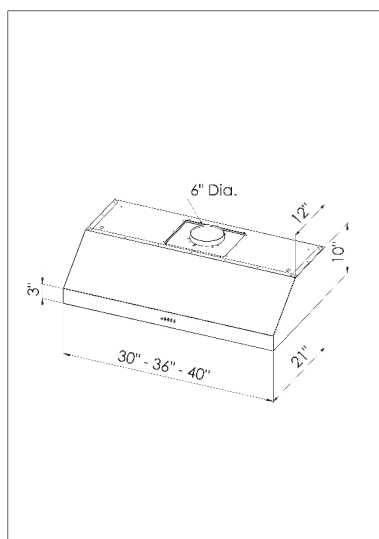

LUCCA RANGE HOOD

LUCCA 30-36-40 inches

FEATURES

- Premium domestic range hood
- Stainless-steel construction
- Welded seams
- Hand-finished edges
- Heavy-duty blower
- Stainless steel design dishwasher safe anti-grease filters
- Time delay shut-off
- Light indicator for grease filter maintenance
- Light indicator for charcoal filter replacement
- Convertible (external venting or recirculating)
- Easy installation system
- Made in Italy

SPECS

- Motor capacity: 560 CFM
- Controls: Electronic push buttons soft touch
- Lights: 2 X LED 30 inches
- 4 X LED 36&40 inches
- ETL approved

ACCESSORIES

- Recirculation kit (not included)



PRODUCT PLUS

A compact cooker hood designed to sit underneath a kitchen cabinet. With easy to use soft touch push buttons to manage fan speeds, and LED lights at the front of the unit.

Light indicator for grease filter maintenance

The cooker hood automatically informs you when the metal grease filter designed for trapping grease in the air requires cleaning. It is of utmost importance to clean these filters to ensure cooker hood components are protected and to pre-vent bad odours caused by a build-up of grease.

Light indicator for charcoal filter substitution

The cooker hood automatically informs you when the active carbon filter requires replacing. This filter is designed to absorb odours produced when cooking. It is of utmost importance to replace these filters regularly as they lose their efficiency and odour trapping performance.

Adjustable and delayed self-switching off

This function allows you to programme delayed cooker hood shutdown which, in the shortest time possible, provides the right level of air purity in your kitchen.

TEGA RANGE HOOD 30 - 36 inches

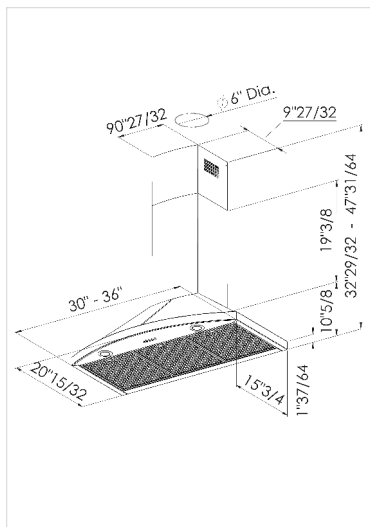

TEGA

TEGA 30 - 36 inches

FEATURES

- Premium domestic range hood
- Stainless-steel construction
- Welded seams
- Hand-finished edges
- Heavy-duty blower
- Stainless-steel design filters dishwasher safe
- Time delay shut-off
- Light indicator for grease filter maintenance
- Light indicator for charcoal filter replacement
- Convertible (external venting or recirculating)
- Eady installation system
- Made in Italy

SPECS

- Motor capacity: 560 CFM
- Controls: Electronic push buttons soft touch
- Lights: 2 X LED
- ETL approved

ACCESSORIES

- Recirculation kit (not included)



PRODUCT PLUS

The semi round Tega cooker hood complements the curved lines of your kitchen. With simple functions this hood not only looks the part, it's practical and functional for the modern chef.

There are 4 speed controls available to clear cooking vapours quickly and efficiently. LED lights provide brilliant illumination over your cooking surface, and give your kitchen ambience. Maintenance is easy with design grease filters, as they are washable for no-fuss cleaning.

Light indicator for grease filter maintenance

The cooker hood automatically informs you when the metal grease filter designed for trapping grease in the air requires cleaning. It is of utmost importance to clean these filters to ensure cooker hood components are protected and to pre-vent bad odours caused by a build-up of grease.

Light indicator for charcoal filter substitution

The cooker hood automatically informs you when the active carbon filter requires replacing. This filter is designed to absorb odours produced when cooking. It is of utmost importance to replace these filters regularly as they lose their efficiency and odour trapping performance.

Time delay shut-off

This function allows you to programme delayed cooker hood shutdown which, in the shortest time possible, provides the right level of air purity in your kitchen.

VERTICE CEILING HOOD 36 - 48 inches

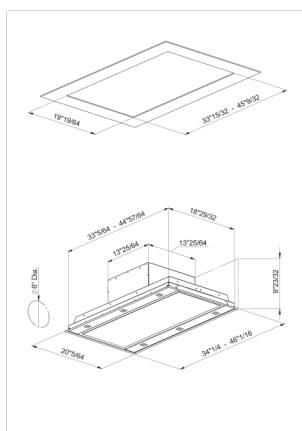

VERTICE

VERTICE 36 - 48 inches

FEATURES

- Premium domestic range hood
- Stainless-steel construction
- Welded seams
- Hand-finished edges
- Heavy-duty blower
- Washable grease filter
- Outlet diameter 6" 360° adjustable.
- Reduced overall dimensions of the motor box to allow installation in small spaces
- New double installation system which allows to fix the double to the masonry or directly to the false ceiling
- Light indicator for grease filter maintenance.
- Light indicator for charcoal filter replacement.
- Perimeter extraction.
- Possibility to install the motor in remote position
- Convertible (external venting or recirculating)
- Made in Italy

SPECS

- Motor capacity: 560 CFM
- Control: Remote control
- Lights 6 X LED

ACCESSORIES

- Recirculation kit (not included)



PRODUCT PLUS

Whilst this stunning VERTICE designer hood will give your kitchen a minimalist and stylish look, the performance is not compromised. The cooking fumes are forcibly extracted through a slit that runs along the perimeter of the hood which increases extraction performance whilst reducing cooker hood noise emissions. The hood boasts 4 speeds and a light indicator to inform you when the grease filters require cleaning. The powerful motor and 6 LED lights are controlled by a functional remote control. The hood can be fixed to the masonry or a false ceiling and, if required, the motor can be installed away from the unit (extraction only).

Light indicator for grease filter maintenance

The cooker hood automatically informs you when the metal grease filter designed for trapping grease in the air requires cleaning. It is of utmost importance to clean these filters to ensure cooker hood components are protected and to pre-vent bad odours caused by a build-up of grease.

Light indicator for charcoal filter substitution

The cooker hood automatically informs you when the active carbon filter requires replacing. This filter is designed to absorb odours produced when cooking. It is of utmost importance to replace these filters regularly as they lose their efficiency and odour trapping performance.

Adjustable and delayed self-switching off

This function allows you to programme delayed cooker hood shutdown which, in the shortest time possible, provides the right level of air purity in your kitchen.



FORTÉ[®]
M I L A N O