



COOKING

Professional Custom Series Built-In Electric 30"/36"W. Rangetop



Standard Features & Accessories

All models include

- Strong, wear-resistant glass ceramic top
- QuickCook™ surface elements utilize ribbon technology—elements reach full power in about three seconds
- High infrared transmission for fast cooking, regardless of the type of cookware used

30"W. 4B model includes

- Left front element—6-1/2" 1,500 watts
- Left rear (dual element)—9" – 6" 2,500 – 1,000 watts
- Right front element—7" 1,800 watts
- Right rear element—7" 1,800 watts
- Bridge element between right front and right rear elements; creates a continuous heated surface—800 watts

36"W. 4B model includes

- Left front (dual element)—9" – 6" 2,500 – 1,000 watts
- Left rear—6-1/2" 1,200 watts
- Center front/rear—7" 1,800 watts/7" 1,800 watts
- Bridge element between center front and center rear elements; creates a continuous heated surface—800 watts
- Right front element—6-1/2" 1,500 watts
- Right rear element—8-1/4" - 4-3/4" 2,200 – 750 watts

Model Options

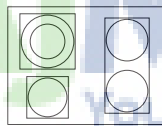

VERT530-4B*
30"W. Four-Burner
Rangetop

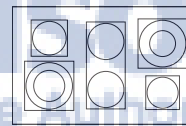

VERT536-6B*
36"W. Six-Burner
Rangetop

FINISH DETAILS FOR VERT MODELS ONLY

- Stainless Steel (SB)
 - Stainless steel control panel
 - Black glass ceramic top
 - Stainless steel knobs
- White (SW)
 - Stainless steel control panel
 - White glass ceramic top and white knobs.
- Brass Trim Option (BR)—nameplate, drip tray pull/trim, and knob bezels. Brass components have a durable protective coating for maintenance-free normal use.

*Shown throughout with standard island trim. See **Installation Notes & Accessories** for details.

ORDERING INSTRUCTIONS

First specify model number, and then color code (VERT530-4BSB). If ordering optional brass trim, specify code at end (VERT530-4BSBBR).





COOKING

Professional Custom Series Built-In Electric 30"/36"W. Rangetop



★ Please see Installation Notes & Accessories for important installation information, including backguard, high-shelf, and island trim.

Dimensions & Specifications

PRODUCT DIMENSIONS



VERT530-4B
Professional 30"W.
Four-Burner Rangetop



VERT536-6B
Professional 36"W.
Six-Burner Rangetop

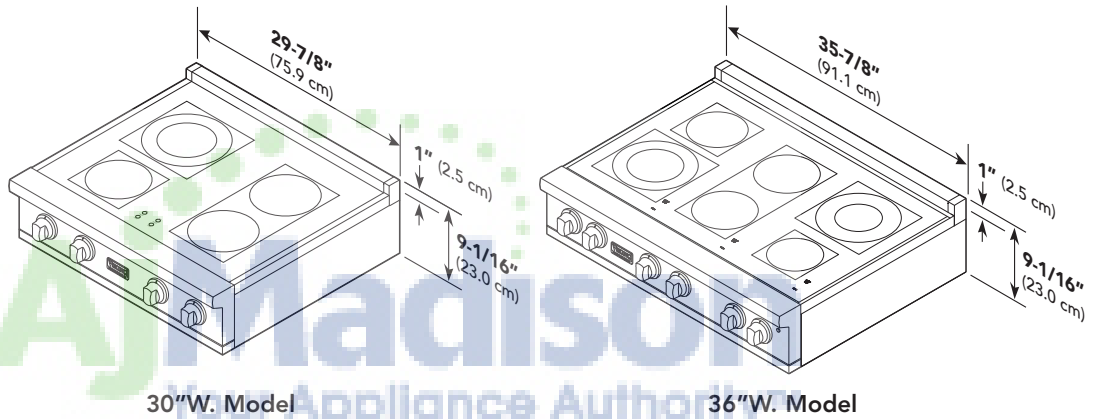

Appliance Authority
800-570-3355

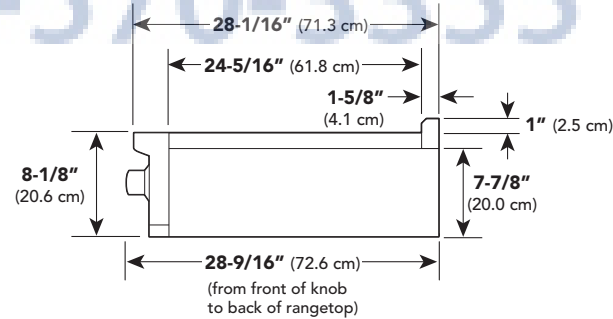

| | VERT530-4B | VERT536-6B |
|------------------------------|-------------------|-----------------------|
| Overall width | 29-7/8" (75.9 cm) | 35-7/8" (91.1 cm) |
| Overall height (from bottom) | | |
| To top of glass frame | | 8-1/8" (20.6 cm) |
| To top of island trim | | Add 1" (2.5 cm) |
| To top of 8" backguard | | Add 8" (20.3 cm) |
| To top of high shelf | | Add 23-1/2" (59.7 cm) |
| Overall depth (from rear) | | |
| To end of side panel | | 24-5/16" (61.8 cm) |
| To end of landing ledge | | 28-1/16" (71.3 cm) |
| To end of knobs | | 28-9/16" (72.6 cm) |





Dimensions & Specifications

CLEARANCE DIMENSIONS

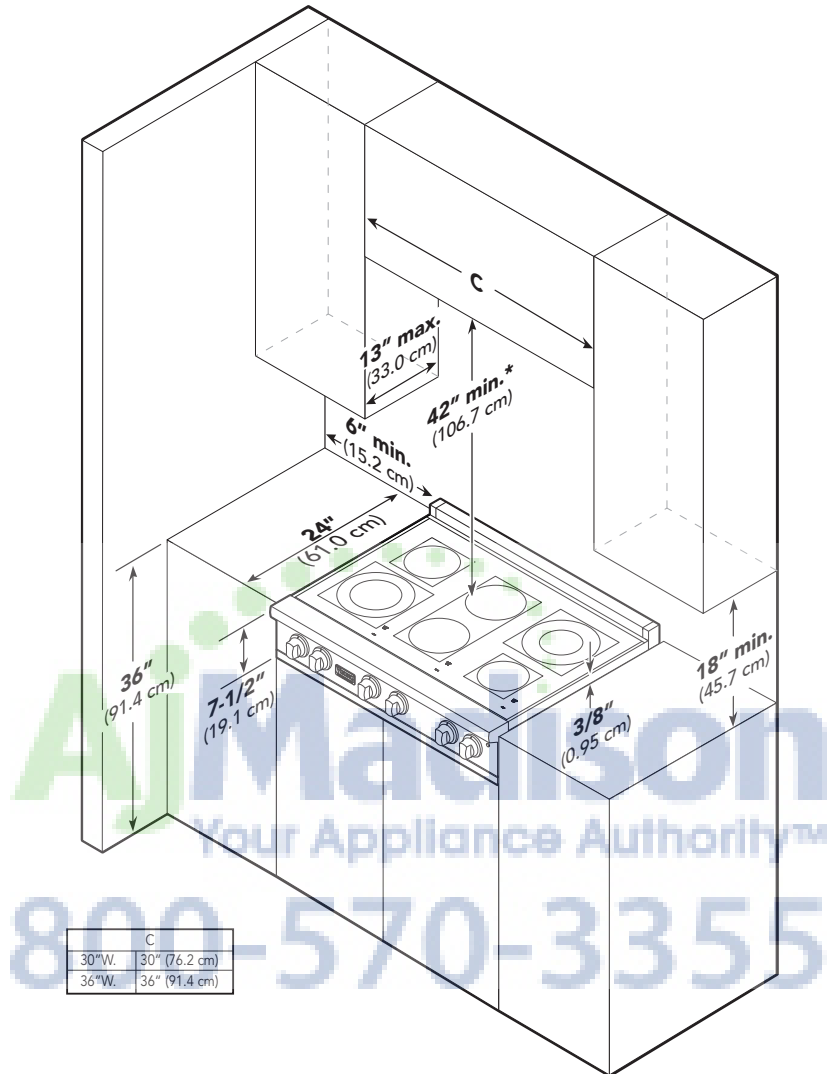

Minimum clearances from adjacent combustible construction*

- Below cooking surface (36" (91.4 cm) and below)
 - o Sides—0"
 - o Rear—0" with backguard or high-shelf; 0" with island trim and non-combustible rear wall; 6" (15.2 cm) with island trim and combustible rear wall.
- Above cooking surface, i.e., above 36" (91.4 cm)
 - o Sides—6" (15.2 cm)
 - o Within 6" (15.2 cm) side clearance, wall cabinets no deeper than 13" (33.0 cm) must be minimum 18" (45.7 cm) above cooking surface.
 - o Wall cabinets directly above product must be minimum 36" (91.4 cm) for open top burners above cooking surface.

1. This rangetop may be installed directly adjacent to existing 36" (91.4 cm) high base cabinets. **Important:** The top grate support **must** be 3/8" (0.95 cm) above the adjacent base cabinet countertop.
2. The rangetop **cannot** be installed directly adjacent to sidewalls, tall cabinets, tall appliances, or other side vertical surfaces above 36" (91.4 cm) high. There must be a minimum of 6" (15.2 cm) side clearance from the rangetop to such combustible surfaces above the 36" (91.4 cm) counter height.
3. Within the 6" (15.2 cm) side clearance to combustible vertical surfaces above 36" (91.4 cm), the maximum wall cabinet depth must be 13" (33.0 cm) and wall cabinets within this 6" (15.2 cm) side clearance must be 18" (45.7 cm) above the 36" (91.4 cm) high countertop.

4. Wall cabinets above the rangetop must be a minimum of 42" (106.7 cm) above the rangetop cooking surface for the full width of the rangetop.

* This minimum height requirement does not apply if a rangehood is installed over the cooking surface.

Do not install two or more units side-by-side.



COOKING

Professional Custom Series Built-In Electric 30"/36"W. Rangetop



UTILITY REQUIREMENTS



GAS

- Not applicable



ELECTRICAL

- Electrical connection—
 - 40 amp—30"W.
 - 60 amp—36"W.
- Three-wire, 240/208V, 60Hz. Unit is equipped with No. 10 ground wire in conduit. Should be fused separately.
- Check your national and local codes regarding this unit.
- Maximum amp usage—
 - VERT530
 - 240V—34.6
 - 208V—29.8
 - VERT536
 - 240V—49.2
 - 208V—42.6



PLUMBING

Not applicable

Installation Requirements

ACCESS REQUIREMENTS



VERT530-4B
Professional 30"W.
Four-Burner Rangetop



VERT536-6B
Professional 36"W.
Six-Burner Rangetop

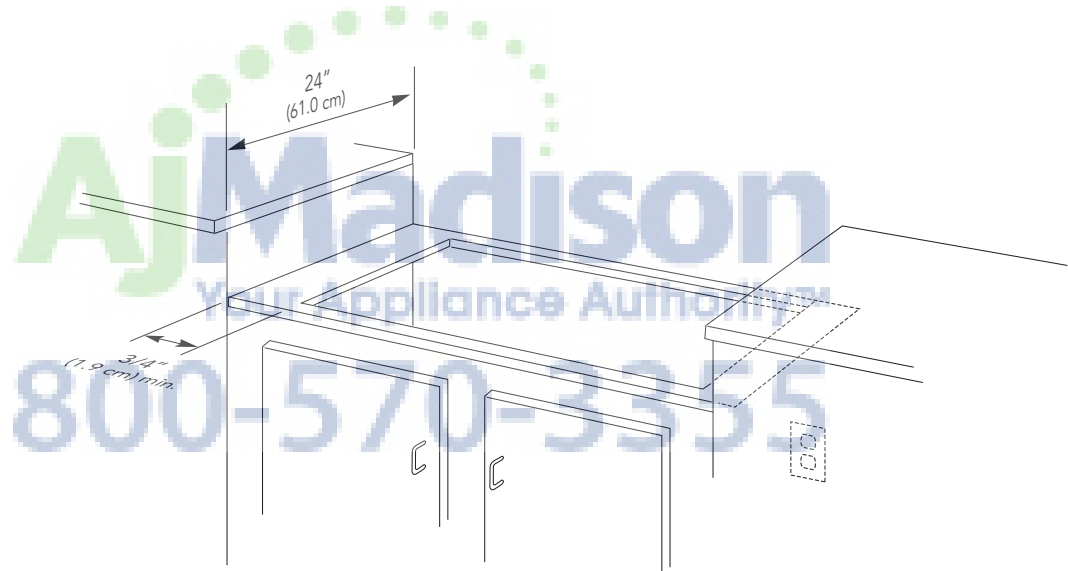

| | VERT530-4B | | VERT536-6B | |
|-----------------------------|-------------------|-----------------|-------------------|-----------------|
| Cutout width | 30" (76.2 cm) | | 36" (91.4 cm) | |
| Cutout height | 7-1/2" (19.1 cm) | | | |
| Cutout depth | 24" (61.0 cm) | | | |
| Surface element rating | 240V | 208V | 240V | 208V |
| Left front (dual element) | N/A | N/A | 2,500/1,000 watts | 1,875/750 watts |
| Left front (single element) | 1,500 watts | 1,125 watts | N/A | N/A |
| Left rear (dual element) | 2,500/1,000 watts | 1,875/750 watts | N/A | N/A |
| Left rear (single element) | N/A | N/A | 1,200 watts | 900 watts |
| Center front/rear | N/A | N/A | 1,800 watts | 1,350 watts |
| Bridge | 800 watts | 600 watts | 800 watts | 600 watts |
| Right front | 1,800 watts | 1,350 watts | 1,500 watts | 1,125 watts |
| Right rear (dual element) | N/A | N/A | 2,200/750 watts | 1,650/560 watts |
| Right rear (single element) | 1,800 watts | 1,350 watts | N/A | N/A |





COOKING Professional Custom Series Built-In Electric 30"/36"W. Rangetop



✦ Installation Notes & Accessories

A backguard, high-shelf, or island trim must be used for all installations.

Island Trim

- Stainless Steel (SS)
- Coordinates with all finishes
- For island/peninsula installation
- Can replace backguard if wall is non-combustible
- Included (and shipped) automatically with 30"W. ranges

| Model | Description | Approx. ship wt. lbs. (kg) |
|--------|-------------------|----------------------------|
| P30TII | 30"W. island trim | 10 (4.5) |
| P36TII | 36"W. island trim | 10 (4.5) |

High-shelf

- Stainless Steel (SS)
- Coordinates with all finishes
- Shelf comes attached to a 24"H. backguard

| Model | Description | Approx. ship wt. lbs. (kg) |
|---------|------------------|----------------------------|
| B30HS24 | 30"W. high-shelf | 45 (20.3) |
| B36HS24 | 36"W. high-shelf | 45 (20.3) |

8"H. Backguard

- Stainless Steel (SS)
- Coordinates with all finishes

| Model | Description | Approx. ship wt. lbs. (kg) |
|--------|-----------------|----------------------------|
| P30BG8 | 30"W. backguard | 14 (6.3) |
| P36BG8 | 36"W. backguard | 14 (6.3) |

Countertop Side Trim

- Stainless Steel (SS)
- Coordinates with all finishes
- One pair of trim
- Installs on side of unit; overlaps countertop

| Model | Description | Approx. ship wt. lbs. (kg) |
|--------|-------------|----------------------------|
| P24CST | Side trim | 2 (0.9) |

Countertop Rear Trim

- Stainless Steel (SS)
- Coordinates with all finishes

| Model | Description | Approx. ship wt. lbs. (kg) |
|--------|----------------------------|----------------------------|
| P30CRT | 30"W. countertop rear trim | 2 (0.9) |
| P36CRT | 36"W. countertop rear trim | 2 (0.9) |

Compliance Information



WARRANTY INFORMATION*

- One-year full warranty—complete product
- Five-year limited warranty—all electric elements
- Ninety-day limited warranty—cosmetic parts such as glass, painted, and decorative items
- Lifetime limited warranty—stainless steel exterior

* For complete warranty see *Use & Care Guide*. Warranty valid on Viking products shipped within the United States and Canada.

