

BI-30U/S



FEATURES

LED Lighting for brighter interior

Dual refrigeration keeps food fresher longer

Air purification system fights spoilage, odors

Crispers and deli drawers in low-temp, high-humidity zones for optimum freshness

Microprocessor control assures peak performance

Freshness cards for maximum food preservation

Water-filtration system for ice reduces contaminants, chlorine taste and odor

Rigorously tested in our U.S. manufacturing facilities to ensure decades of use

Exceptional 24/7 support from Madison, WI-based Customer Care team

Over-and-under refrigerator/freezer storage

Magnetic door seal system locks in cold air

Automatic ice maker with "max ice" feature

Adjustable shelves for maximum convenience

ACCESSORIES

Air Purification Cartridge

Built-In Custom Side Panel Mounting Kit

Dual Installation Kit

Egg Container

Stainless Steel Side Panel

Water Filter 4204490

White Side Panel

Stainless steel kickplate

Grilles for 83" or 88" finished height (84" is standard)

Side panel mounting kit

Dual Installation Kit with Dual Wide Grille

Accessories are available through an authorized Sub-Zero dealer.
For local dealer information, visit subzero-wolf.com/locator.



HANDLE OPTIONS

PRO



TUBULAR



PRODUCT DETAILS

REFRIGERATOR

- 3 Adjustable glass shelves
- 1 Stationary glass shelf
- 1 High-humidity drawer with divider
- 1 Storage drawer with divider
- 2 Adjustable door shelves
- 1 Stationary door shelf
- Adjustable dairy compartment

FREEZER

- Full-extension roll-out freezer drawer
- Two-tier wire storage baskets
- Automatic ice maker

PRODUCT SPECIFICATIONS

Model	BI-30U/S
Dimensions	30"W x 84"H x 24"D
Door Clearance	31 1/4"
Drawer Clearance	23 5/8"
Weight	462 lbs
Refrigerator Capacity	13.2 cu. ft.
Freezer Capacity	4.2 cu. ft.
Electrical Supply	115 VAC, 60 Hz
Electrical Service	15 amp dedicated circuit
Receptacle	3-prong grounding-type

ELECTRICAL

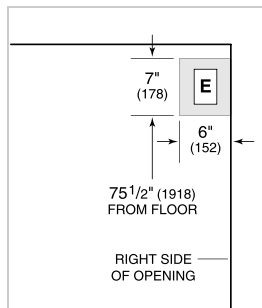

PLUMBING

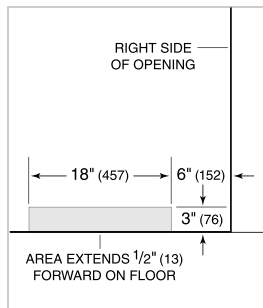

NOTE: Dimensions in parenthesis are in millimeters unless otherwise specified

INTERIOR VIEW

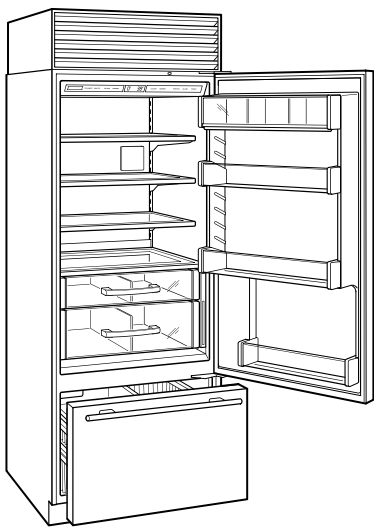

This illustration is intended for interior reference only and may not represent the exterior of the model being specified.

DIMENSIONS

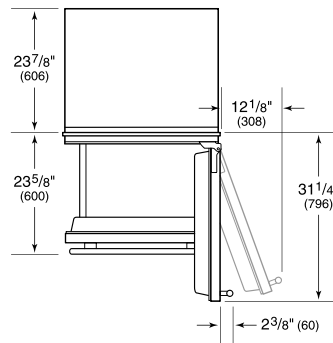
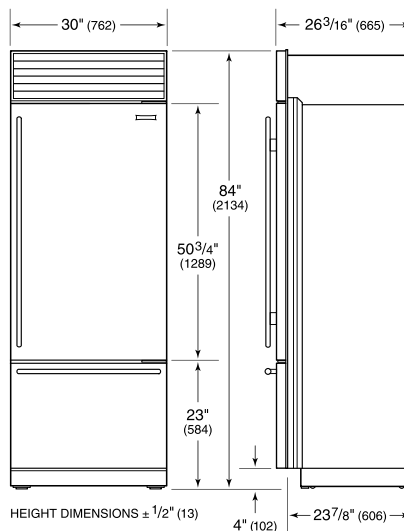

STANDARD INSTALLATION

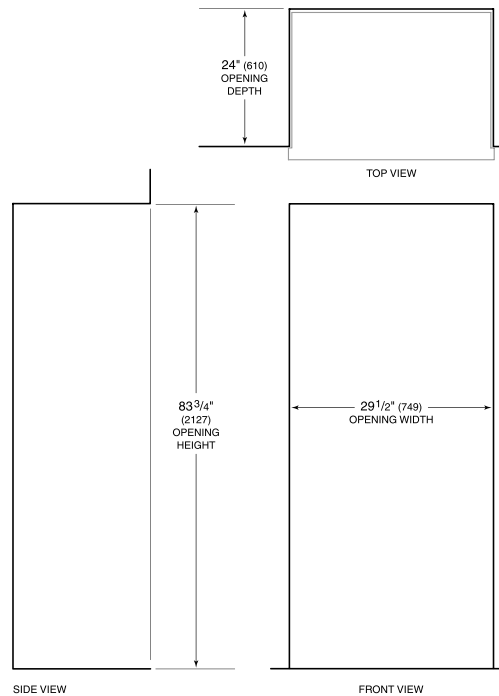

NOTE: Shaded line represents profile of unit.