

Model ROE69SC



Model ROE9Y-60



Model ROE11Y-60



ELECTRIC
OVEN

ACME

ACME KITCHENETTES CORP.

24

21

24

69

4

36



ABOUT ACME

Acme has been in business for over 80 years. We have the knowledge and experience to manufacture a kitchenette of superior quality that is unique and dependable. Acme has owned the King Mini Kitchen name and parts business since 1996, and continues to provide replacement parts and complete new kitchens for King customers. As you review this catalog you'll discover just how versatile we are.

ACME'S PLEDGE

We are committed to providing the best kitchenette in the industry at a very competitive price. Our sales and service people are dedicated to customer satisfaction and provide fast and reliable service.

CUSTOMIZE YOUR KITCHENETTE

Acme can manufacture to suit your needs—we are very flexible in the design and construction of our products. We manufacture standard sizes for the industry as well as custom sizes. Our countertops are offered in stainless steel, laminate, or solid surface. Acme manufactures a full line of Barrier-Free kitchens for handicap accessibility.

WARRANTY

Acme provides a one year warranty for the entire unit against manufacturing defects, including parts and labor with an optional extended warranty on the sealed-in refrigeration system.

SPECIFICATIONS are subject to change as required.

COLOR/FINISHES in this catalog may vary slightly from actual color due to the printing process.

Please contact our customer service department for all inquiries to receive prompt and courteous service.

*Call our toll free number at **800-322-4191**.*

*Fax inquiries can be directed to **518-828-4011**.*

*Email inquiries can be sent to:
info@acmekitchenettes.com*



Advantage!
www.gsaAdvantage.gov

GSA Contract #GS07F9698G



Front cover includes model ROE69SC and includes a solid surface countertop, undermount stainless steel sink bowl, single lever faucet, three burner ceran cooktop, electric oven, removable refrigerator, wall cabinets, microwave oven and range hood. Cabinet door fronts are solid wood.

www.acme3in1.com

EFFICIENCY MODELS ARE AVAILABLE IN STANDARD WIDTHS OF 30" , 36" , 39" , 42" AND 48" .

All units are available with the sink located on either side when facing the unit.

Electric burners can be wired for either 115 or 230 volt operation and components are UL listed.

Gas burners may be for use with natural or L.P. gas and equipped with electronic ignition. Components AGA listed.

Standard Finishes: White, almond, bisque, black or gray.

Cabinetry constructed of thermal fused melamine on particleboard.

- All refrigerators are removable which allows for easy maintenance or future replacement.
- The 30" model includes a 4.3 cu.ft. capacity refrigerator, black or white only.
- The 36" to 48" wide models include a 5.1 cu.ft. capacity refrigerator with automatic cycle defrost and a frame to accept matching front door panels.
- Refrigerator details listed on page 9.
- Units may be modified and customized. Options available as outlined on page 9.

RES11Y-42 with recessed countertop



RES9Y-30.



RGS11Y-39

RES11Y-48L with high-pressure decorative laminate countertop and cabinet finish.



PLAN VIEWS OF TYPICAL EFFICIENCY MODELS

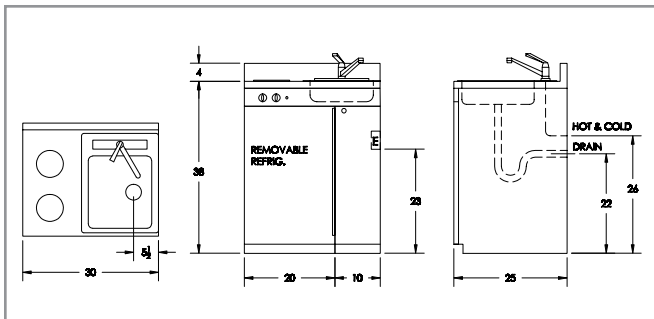

RES9Y-30RH

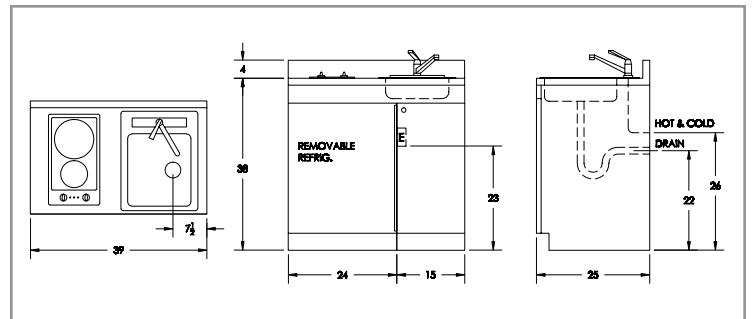

RES11Y-39RH

FULL FEATURE MODELS AVAILABLE IN STANDARD WIDTHS OF 48", 51", 54", 60", 63", 69" AND 72".

ROE9Y models include a 20 gauge stainless steel countertop with sink bowl, single lever faucet, sink strainer, four electric burners, 20" wide electric oven and removable refrigerator. Electric models operate on 230 volt, all components UL listed.

ROG10Y models substitute a 20" wide gas oven and 4 burners with electronic ignition. Available for use with natural or LP gas, all components AGA listed.

Finish: Black or white.

Cabinetry constructed of thermal fused melamine on particleboard.

All refrigerators are removable which allows for easy maintenance or future replacement.

The 48" and 51" wide models include a 4.3 cu.ft. capacity refrigerator.

The 54" to 72" wide models include a 5.1 cu.ft. capacity refrigerator with automatic cycle defrost. Refrigerator details listed on page 9.

Acme also offers units 75" to 99" wide to include an upright refrigerator.

Units may be modified and customized. Options available as outlined on page 9.



ROE9Y-60 with Options

At left: ROE9Y-48

Below: ROE9Y-72



PLAN VIEWS OF TYPICAL FULL-FEATURE KITCHENETTES

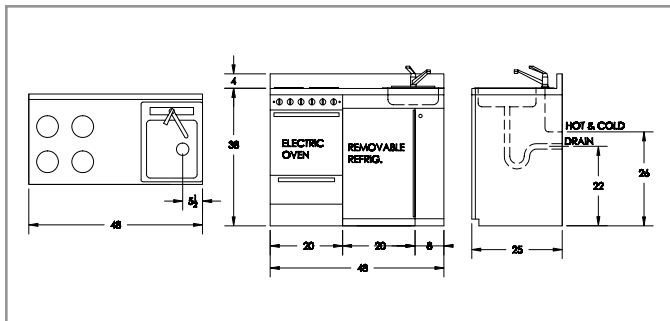

ROE9Y-48RH

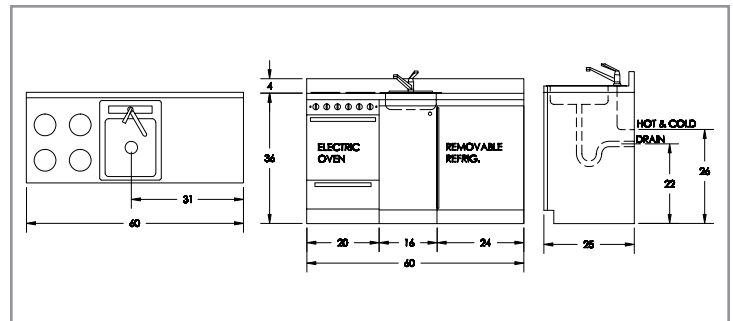

ROE9Y-60RH



ROE11Y-60 Modification #2 This model provides additional base storage space and allows for use of a separate upright refrigerator. Model shown includes a 20 gauge stainless steel countertop, sink bowl, single lever faucet, sink strainer, four electric burner elements and a 24" wide electric oven with black glass door and convection bake feature. Many options are possible; you may substitute a ceran or gas burner cooktop, include a dishwasher and alter the appearance by choosing a custom color, countertop and door finish.



Above: **RS60MW** shown with custom solid surface countertop and thermofoil door fronts.

Above right: **RES11Y60 MW** with cook top in chrome laminate finish.

At right: **RS60MW**, a very versatile and practical unit! Features a laminate countertop with drop-in stainless steel sink bowl, single lever faucet and sink strainer, 5.1 cu.ft. removable refrigerator with automatic cycle defrost, storage drawers and .7 cu.ft. microwave oven built into base. Available in various widths and finishes. An electric or gas cooktop can be added.



RES11Y-72 shown with recessed, 20 gauge stainless steel countertop, 2 burner ceran cooktop and 5.1 cu.ft. removable refrigerator with automatic cycle defrost. Use an alternate countertop and choose your standard or custom finish.



Acme will assist you in designing a kitchen that will be manufactured to your specific requirements and will provide a compact, complete and unique solution for your installation.

At right: **Natural Bamboo Plywood cabinetry.** This material is 100% ENVIRONMENTALLY FRIENDLY, durable, safe and easily renewable. All Acme models are available for an upgrade to include this GREEN option. **ROE/G72** (shown at right) includes stainless steel countertop, sink, faucet and strainer, removable refrigerator, 4 gas burner cooktop, electric oven with convection bake, wall cabinets, rear wall shield, range hood and microwave oven.



Bamboo is a 100% green product, so sturdy and wear-resistant that it's used for flooring!



At left: **CL60DW** Includes 20 gauge stainless steel countertop with sink bowl, single lever faucet, sink strainer, two burner cooktop, 5.1 cu.ft. removable refrigerator with automatic cycle defrost, 18" wide dishwasher, upper wall cabinets, stainless steel rear wall shield, 1.0 cu.ft. microwave oven and stainless steel range hood. Cabinets have chrome laminate finish.

All Acme units are PRODUCTS WITH PURPOSE: manufactured to be diverse, stylish, functional and efficient.



ROE11Y-60L shown with laminate countertop.

Acme offers a wide variety of options. Simply specify the overall width of the unit, choose a countertop, pick the cabinet construction with finishes and the appliances to be included.

COUNTERTOPS:

- A. 20 gauge stainless steel, type 304 with a #4 satin finish.
- B. High-pressure decorative laminate by Wilsonart, Nevamar or Formica.
- C. Solid Surfaces available: DuPont Corian, Formica Solid Surface, LG Hi Macs or Wilsonart Solid Surface.

CABINET CONSTRUCTION:

- D. Standard 5/8" thick industrial grade particleboard with melamine finish: white, almond, bisque, black or gray.
- E. 5/8" thick particleboard with a high-pressure decorative laminate finish by Wilsonart, Nevamar or Formica.
- F. Plywood construction with high-pressure decorative laminate finish.
- G. Bamboo plywood construction and door fronts.
- H. Thermofoil door fronts.
- I. Solid wood door fronts.



ROE11Y-69L with laminate countertop and optional equipment.



ROE69SC shown with solid surface countertop, undermount stainless steel sink bowl, single lever faucet, sink strainer, ceran cooktop, electric oven with black glass door, 5.1 cu.ft. removable refrigerator with automatic cycle defrost, upper wall cabinets, stainless steel rear wall shield, 1.0 cu.ft. microwave oven and stainless steel range hood. Solid wood door fronts.



ROE11Y-69 shown with stainless steel countertop and solid wood door fronts.

**BARRIER-FREE MODELS
ARE AVAILABLE IN STANDARD WIDTHS
OF 60", 63", 69", 72", 75" AND 78"**

Acme has incorporated all of the structural, design and component features necessary to conform to the strictest local and state codes for wheelchair and physically disabled accessibility. Our units maximize kitchen efficiency in minimum spaces. Standard sizes are listed and custom sizes are readily available.

General Specifications: Standard barrier-free unit kitchens include a 20 gauge stainless steel countertop with sink bowl, single lever faucet, sink strainer, two burners (either gas or electric) and 6.0 cu.ft. removable refrigerator with automatic cycle defrost. The standard cabinetry is constructed of 5/8" thick 48 lb industrial grade particleboard which is fused on both sides with acid resistant thermoset melamine to exceed the standards of the American Laminators Association.

Optional Equipment:

- Wall cabinet sections to match base units.
- Wall shields available for rear and/or side walls in either stainless steel or laminate as desired.
- Range hood.
- Microwave Oven



Special Construction: Countertop and sink are on one plane, 34" from floor and continuous 34" height extends above refrigerator. The sink drain is located on the side of the bowl rather than the center to maximize under sink leg room.

Codes for Barrier-Free models: Acme's modular barrier-free units meet all Federal ADA requirements, New York City local law 58/87 and ANSI A117.1-1986 specifications.

Removable Undersink Cabinet: Available on all barrier-free units for conversion to accommodate wheelchair access.

Finishes: Standard finishes include white, bisque, gray, almond or black. Refer to pages 9 and 10 for additional finishes and options. All units are available with the sink located on either side when facing the unit.



RES60BF with optional wall cabinet, stainless steel rear wall shield, range hood and microwave oven.



RES60BF-A with removable undersink cabinet



RS60BF-L with custom finish laminate and available with drop-in cooktop assemblies as shown on page 8.

PLAN VIEW OF TYPICAL BARRIER-FREE KITCHENETTES

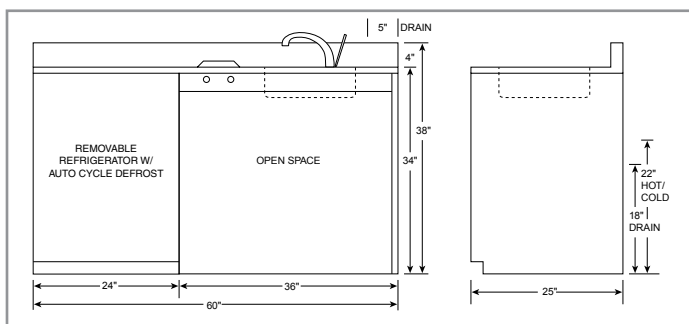

TWO BURNER ELECTRIC AND GAS COOKTOPS



Far left: **2EE**: Two burner ceran cooktop with stainless steel frame. Available in 115 or 230 volts. The 115 volt cooktop shall have one 1000 watt and 1400 watt element, 2.4 KW, 20.87 amps. The 230 volt cooktop shall have one 1200 watt and one 1700 watt element, 2.9 KW, 12.61 amps. Each burner has a 3 circuit cooking zone and a power indicator light. Supplied 3 wire, single phase A.C. and requires direct connection. Dimensions: 11 $\frac{1}{3}$ " x 20 $\frac{1}{16}$ " x 2 $\frac{1}{2}$ ", UL and CSA approved.

At Left **2EG**: Stainless steel sealed burner gas cooktop with electronic ignition. Front burner 6,000 BTU/hr and rear burner 10,000 BTU/hr. 120 volt, 0.1 amp max.. Easily converts for use with natural or L.P. gas. Dimensions: 11 $\frac{1}{3}$ " x 20 $\frac{1}{16}$ " x 2 $\frac{1}{2}$ "

FOUR BURNER GAS COOKTOP AND ELECTRIC OVEN



Left **4EG**: Four gas burner version also with electronic ignition. Front right burner: 3,500 BTU/hr; front left burner: 11,500 BTU/hr; two rear burners: 6,000 BTU/hr. each. 120 volt, 0.1 amp max. Easily converts for use with natural or L.P. gas. Dimensions: 22 $\frac{7}{8}$ " x 19 $\frac{3}{4}$ " x 2 $\frac{1}{2}$ ";

**Both the 2EG and 4EG are CSA and AGA approved.*

At right: **EEOB** 24" wide, built-in, multi-function electric oven.

Five functions include traditional bake, defrost, convection bake, broil and ventilated broil. Features include cooling fan, oven light, removable cooled door with two tempered glasses (inner thermo-reflector) and automatic shut-off timer.

Lower element: 1300W; upper element: 1000W; infra-red element: 2000W. 240 volt/10 amp max.

Dimensions: 23 $\frac{3}{8}$ " w x 23 $\frac{1}{4}$ " h x 21 $\frac{7}{8}$ " d.
CSA C&US Approved

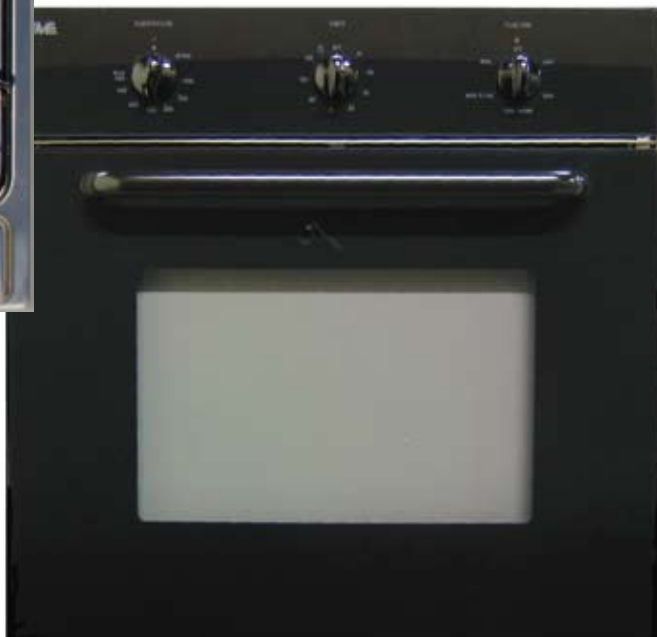

REFRIGERATORS

MODEL BA503-R

- 4.3 cu.ft. capacity
- white or black
- reversible hinges
- 21 lb. capacity freezer section, full height inner door liner, magnetic gasket, manual defrost, high efficiency foam insulation, cushion mounted compressor.
- Dimensions: 19 $\frac{3}{4}$ " w x 20" d x 32 $\frac{1}{2}$ " h
- 78 lbs packed
- 115V, 50/60 cycle, 1.9 amps.
- ETL approval.

MODEL BA603R1

- Automatic cycle defrost
- 5.1 cu.ft. capacity
- white with door frame to accept front panel
- reversible hinges
- 30 lb. capacity freezer section, deluxe crispers, interior light, adjustable shelves, dairy compartment, magnetic door gasket, thin wall insulation, high impact plastic liner, bottle rack, cushion mounted compressor.
- Dimensions: 23 $\frac{5}{8}$ " w x 24" d x 32 $\frac{1}{2}$ " h
- 98 lbs. packed
- 115V, 50/60 cycle, 2.1 amps, UL listed.



BA503-R



BA603R1

OPTIONS AND MODIFICATIONS

Wall cabinets:

Colors and sizes to complement base units.

Wall shields:

Available for rear and/or side walls to match countertop selection.

Light fixture:

Undercabinet, slimline with fluorescent bulb, Requires separate electrical connection.

Garbage disposer:

1/3 hp disposer has 1.5 quart capacity and stainless steel impellers. Operates on 115 volt, 60 cycle AC, and requires separate electrical connection from base unit.

Hot water dispenser:

Delivers no-splash, pressure free water, adjustable from 150 degrees F to 190 degrees F.

Sink cutting board:

Made of hard wood, stores easily in base storage cabinet when not in use.

Range Hood:

24" wide with either stainless steel finish or baked enamel finish. Features two-speed fan, built-in light and filter system. Available for duct-free and ducted installation.

Microwave oven:

1.0 cubic foot capacity, 24" wide, 900 watts and features digital touch control, clock timer and 9 power levels. Runs on 115v., 60 cycle AC, 1.2 KW, 10 amps, plug-in type.

Microwave oven/hood combination:

30" wide, 1.7 cu ft capacity, 1000 watts and features electronic touch controls, clock timer, and 10 power levels. Includes 300 CFM two speed high-capacity exhaust fan. Runs on 115v, 60 cycle AC, 1.5KW, 15 amps, plug-in type.

Modification #1:

Cabinet replacing electric oven

Modification #2:

Cabinet replacing refrigerator

Modification #2A:

Cabinet replacing oven, and range burners eliminated

Modification #3:

Dishwasher installed next to sink; requires separate plumbing & electrical connections.

Modification #4:

Ice maker available on certain models

STANDARD FINISHES

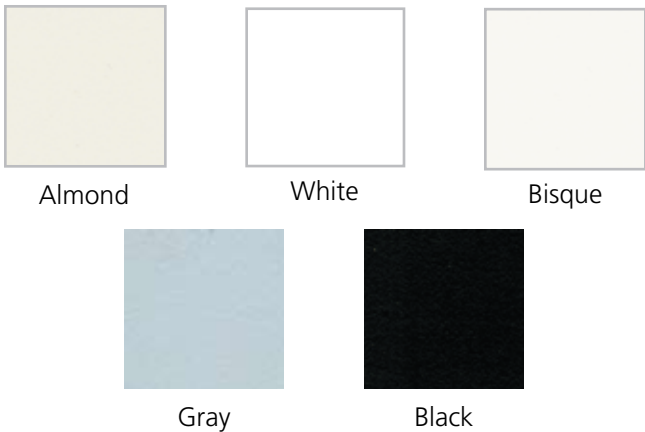

HIGH PRESSURE LAMINATE FINISHES

Light oak, dark oak, maple, cherry, mahogany or satin stainless. Acme can provide HPDL finishes by Wilsonart, Nevamar & Formica. You may visit these websites for a complete selection: www.wilsonart.com; www.nevamar.com; www.formica.com.



CHROME LAMINATE

SOLID SURFACE COUNTERTOPS

Choose from Dupont Corian, Wilsonart Solid Surface, LG Hi-Macs or Formica Solid Surface. A complete selection is available at the following websites: www.corian.com; www.wilsonartsolidssurface.com; www.lghi-macs.com; www.formica.com

CUSTOM DOOR STYLES



SOLID WOOD DOORS



Actual product and color will vary. We highly recommend ordering an actual product sample of the wood species and stain to verify color and finish.



Ordering information

Please contact our sales department with any questions on design or special modifications you may require.

Call on our toll free number **800-322-4191** or fax your plans and specifications to **518-828-4011**.

Email specifications/orders to: sales@acmekitchenettes.com We will review your request and reply promptly.



Factory and Main Office

ACME KITCHENETTES CORP.

P.O. Box 348, Route 9 Hudson, N.Y. 12534

800-322-4191 • 518-828-4191 • FAX: 518-828-4011

www.acmekitchenettes.com sales@acmekitchenettes.com www.acme3in1.com sales@acme3in1.com