

# RETURN AIR GRILLE / ACCESS PANEL FOR AVC & AVH UNITS INSTALLATION INSTRUCTIONS

## Table of Contents

Parts Included in this Kit.....	2
Parts NOT included in this Kit.....	2
Installation .....	2
Left Side Mounting .....	3
Right Side Mounting .....	4

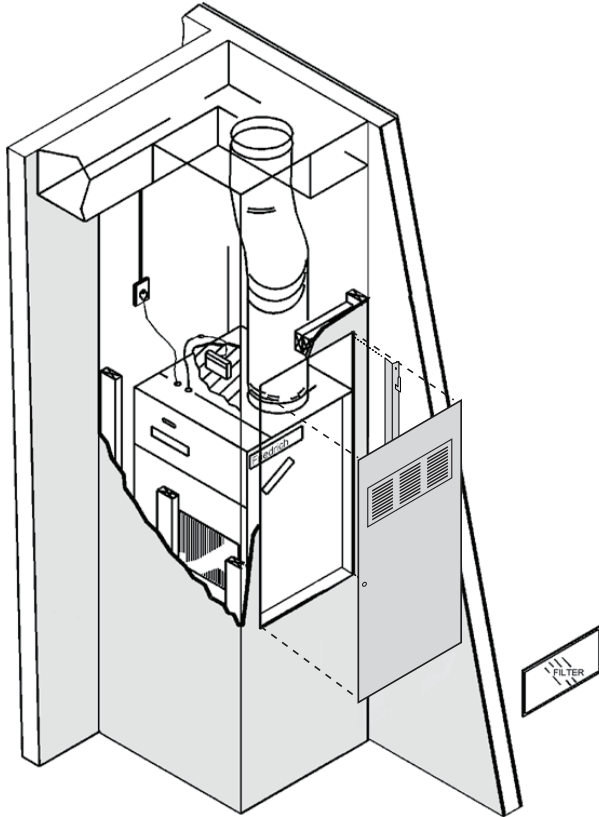

**PROP 65 WARNING  
FOR CALIFORNIA CONSUMERS**

**! WARNING**

Cancer and Reproductive Harm -  
[www.P65Warnings.ca.gov](http://www.P65Warnings.ca.gov)

0140M00513-A



**WARNING**

Only personnel that have been trained to install, adjust, service or repair (hereinafter, "service") the equipment specified in this manual should service the equipment. The manufacturer will not be responsible for any injury or property damage arising from improper service or service procedures. If you service this unit, you assume responsibility for any injury or property damage which may result. In addition, in jurisdictions that require one or more licenses to service the equipment specified in this manual, only licensed personnel should service the equipment. Improper installation, adjustment, servicing or repair of the equipment specified in this manual, or attempting to install, adjust, service or repair the equipment specified in this manual without proper training may result in product damage, property damage, personal injury or death.

IO-917  
10/2018

**Amana** is a registered trademark of Maytag Corporation or its related companies and is used under license to Goodman Company, L.P., Houston, TX, USA. All rights reserved.

5151 San Felipe, Suite 500 • Houston, TX 77056 • [www.amana-ptac.com](http://www.amana-ptac.com)  
© 2018 Goodman Company, L.P.



## Return Air Grille / Access Panel

For use with VTAC units only.

**NOTE:** The following installation instructions apply to the VTAC series units only. Refer to Chassis Installation / Operation Manual for additional information.

### Parts Included in this Kit

ITEM
AVLWP01A-L Return Air Grille / Access Panel (58" Tall x 29" Wide)
2x Mounting Bracket (left and right)
Mounting Screws

### Parts NOT Included in the Kit

ITEM
25" x 20" Filter
5/32" Allen wrench for latch mechanism operation

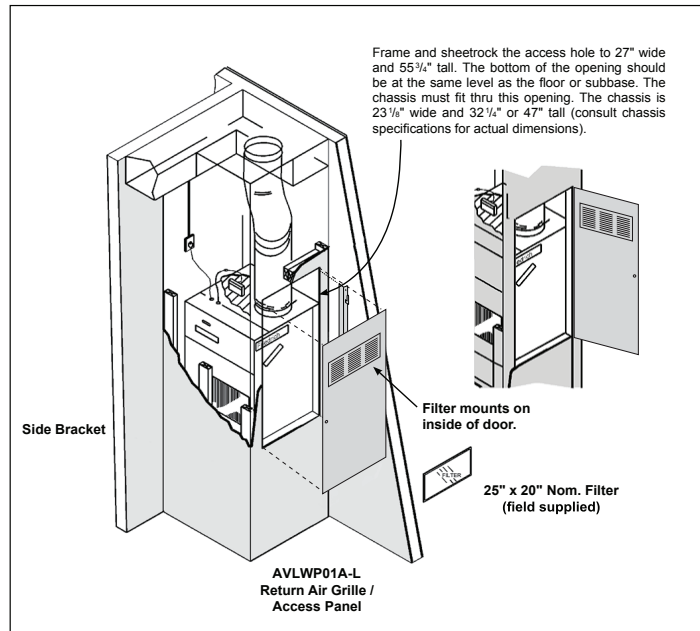

Figure 1

## Installation

Determine the orientation of the door.  
 The AVLWP01A-L Kit comes with two mounting hinges. One mounts to the left side of the opening and locates the return air openings at the lower portion of the door (View A). The other mounts the hinge to the right side of the opening and locates the return air openings at the upper portion of the door (View B). This provides an option for the direction that the door will open. More importantly it can aid in sound attenuation by locating the return air openings away from the evaporator opening on the unit.

**NOTE:** For maximum sound attenuation it is recommended that the left hand bracket (View A) be used for AVC24 & AVH24 models and the right hand bracket (View B) be used for AVC/AVH09, 12 and 18 models.

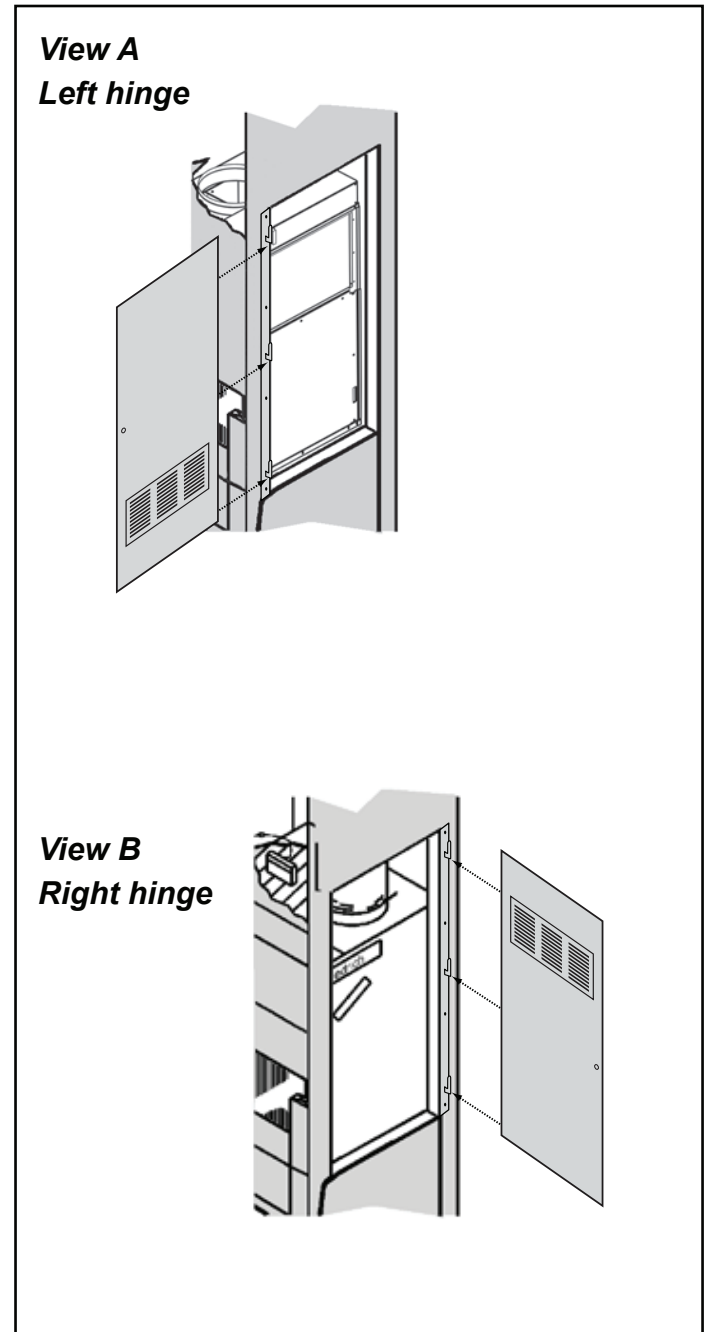

Figure 2

## Left Side Mounting

1. Mount the Side Bracket to the left side of the wall opening. The Side Bracket must be plumb (vertical). Secure with four #8 x 1 1/4" pan-head screws.

**NOTE:** Hinge tabs must point upward.

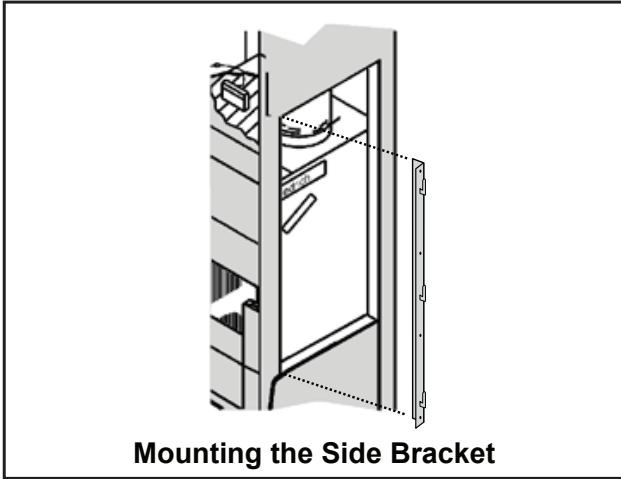

Figure 3

2. Install door onto the Side Bracket. Be sure that the access door has engaged the three tabs, and the door is against the side mounting bracket.

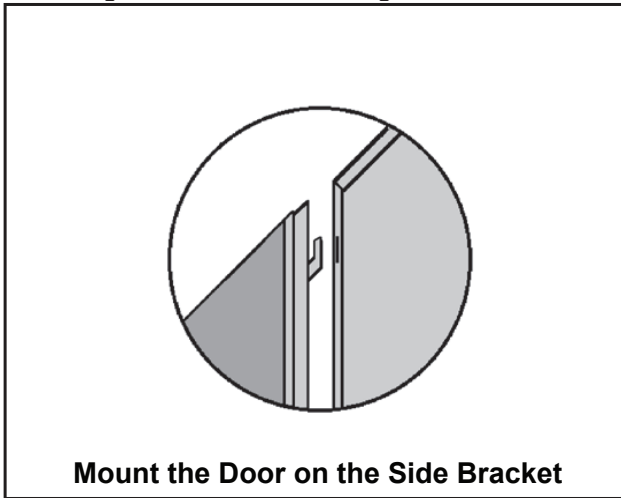

Figure 4

3. Close the door. Draw a temporary horizontal reference line on the wall adjacent to the center of the latch mounting hole.

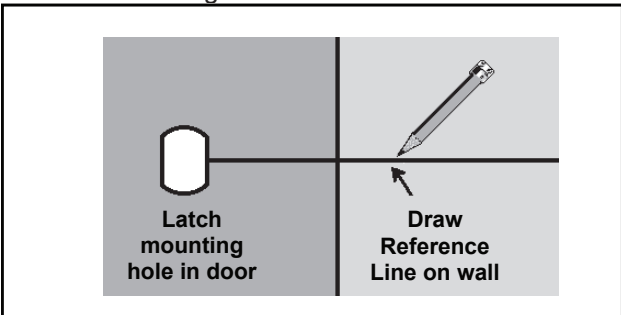

Figure 5

4. Attach the latch bracket to the opening, aligning the bottom of the bracket with the reference line. Use two #18 x 1 1/4 screws. Do not tighten.

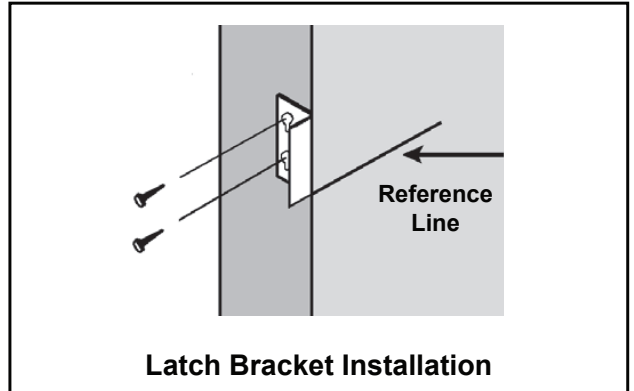

Figure 6

5. Slide the bracket upward and tighten the mounting screws.

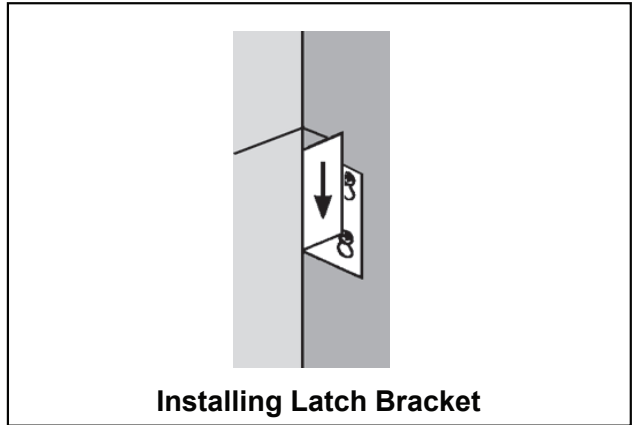

Figure 7

**NOTE:** The latch mechanism should already be factory mounted. This assembly is shown for reference. The latch arm is adjustable to provide a secure, rattle-free installation. Install the filter.

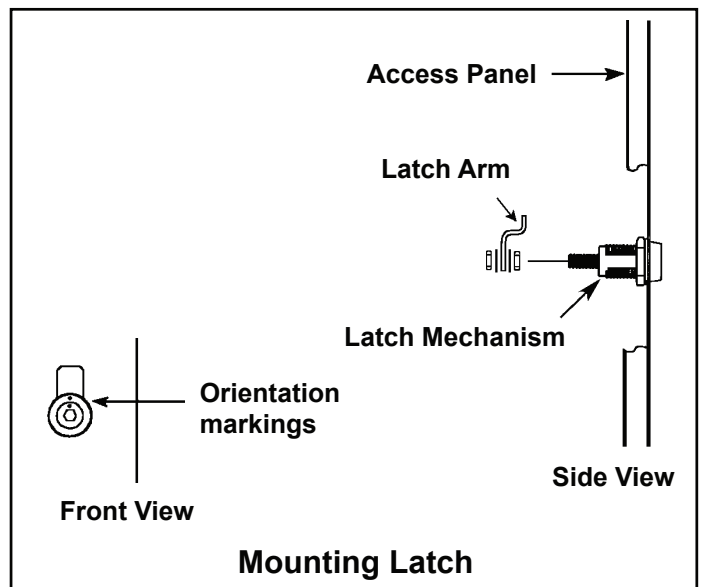
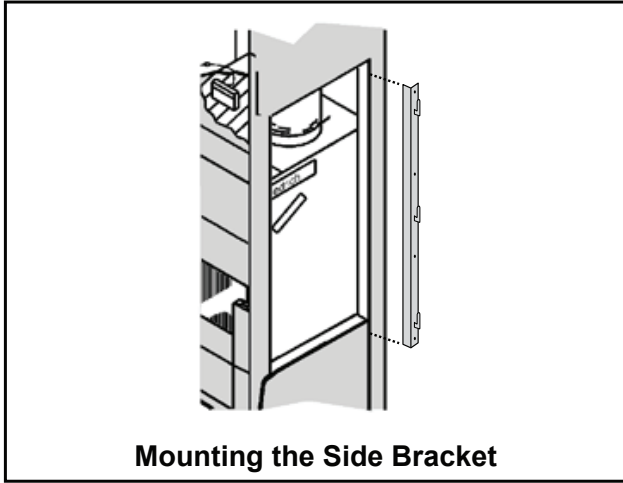

Figure 8

## Right Side Mounting

1. Mount the Side Bracket to the left side of the wall opening. The Side Bracket must be plumb (vertical). Secure with four #8 x 11/4" pan-head screws.

**NOTE:** Hinge tabs must point upward.



**Figure 9**

2. Install door onto the Side Bracket. Be sure that the access door has engaged the three tabs, and the door is against the side mounting bracket.

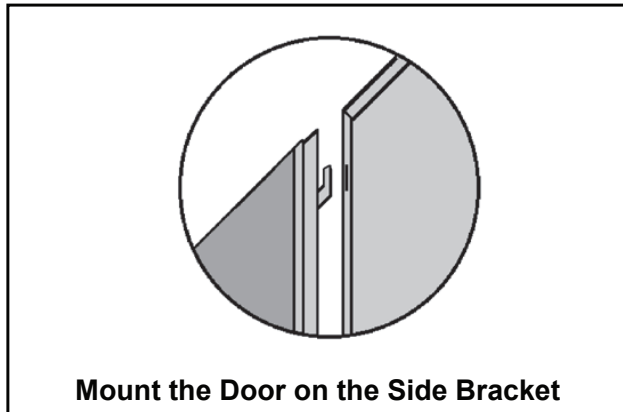

**Figure 10**

3. Close the door. Draw a temporary horizontal reference line on the wall adjacent to the center of the latch mounting hole.

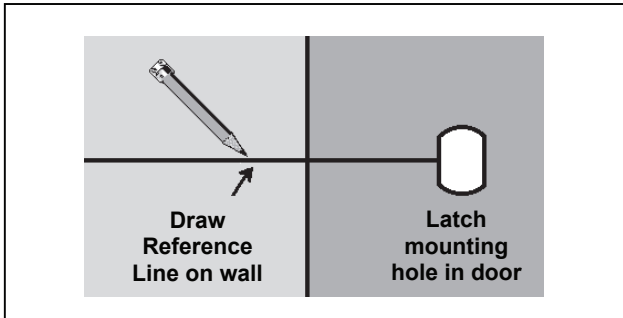

**Figure 11**

4. Attach the latch bracket to the opening, aligning the bottom of the bracket with the reference line. Use two #18 x 11/4 screws. Do not tighten.

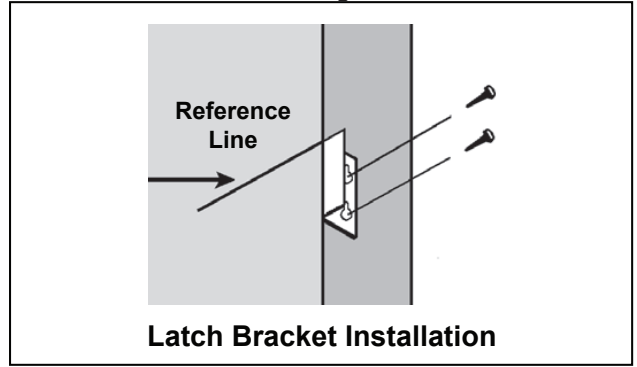

**Figure 12**

5. Slide the bracket upward and tighten the mounting screws.

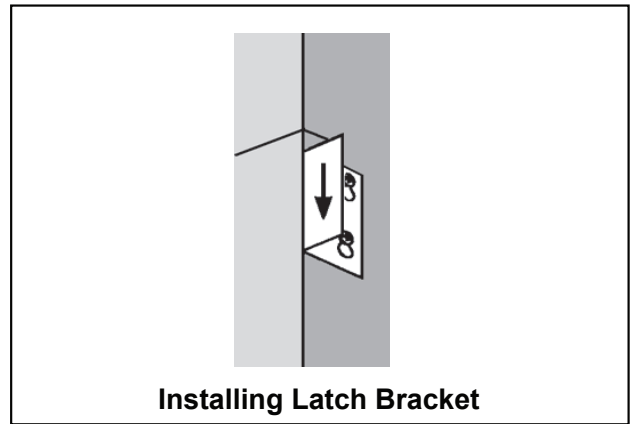

**Figure 13**

**NOTE:** The latch mechanism should already be factory mounted. This assembly is shown for reference. The latch arm is adjustable to provide a secure, rattle-free installation. Install the filter.

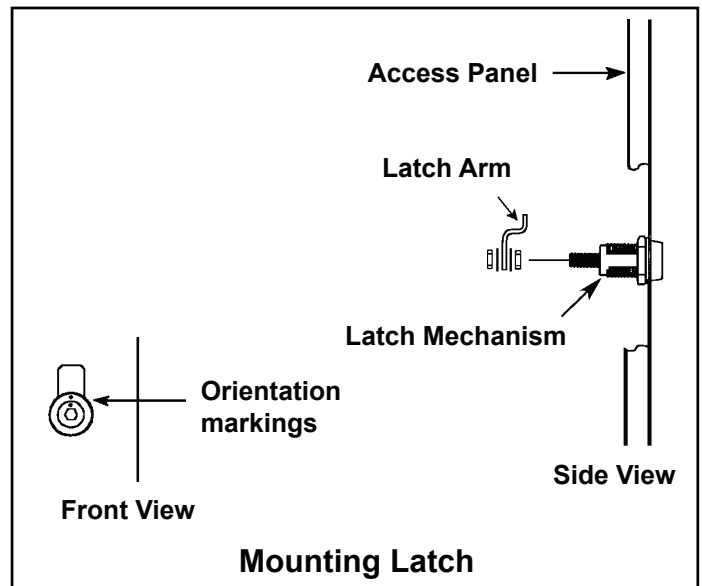

**Figure 14**

**THIS PAGE INTENTIONALLY LEFT BLANK**

**THIS PAGE INTENTIONALLY LEFT BLANK**

**THIS PAGE INTENTIONALLY LEFT BLANK**

**CUSTOMER FEEDBACK**

We are very interested in all product comments.

Please fill out the feedback form on one of the following links:

Amana® Brand Products: (<http://www.amana-hac.com/about-us/contact-us>).

You can also scan the QR code on the right for the product brand you purchased to be directed to the feedback page.



AMANA® BRAND

**Amana** is a registered trademark of Maytag Corporation or its related companies and is used under license to Goodman Company, L.P., Houston, TX, USA. All rights reserved.

5151 San Felipe, Suite 500 • Houston, TX 77056 • [www.amana-ptac.com](http://www.amana-ptac.com)

© 2018 Goodman Company, L.P.