



## AGA CITY24



### *Installation Guide*

**PLEASE READ THESE INSTRUCTIONS BEFORE COMMENCING SITE SURVEY  
OR INSTALLING THIS APPLIANCE.**

**IMPORTANT** : SAVE INSTRUCTIONS FOR FUTURE REFERENCE  
**IMPORTANT** : CONSERVER CES INSTRUCTIONS POUR REFERENCE FUTURE

**For use in USA/Canada**

09/14 EINS 516899

## CONTENTS

SECTION	PAGE
PRODUCT SAFETY	3
GENERAL NOTES	4
HEALTH AND SAFETY	4
GENERAL INSTALLATION REQUIREMENTS	4
REMOVAL FROM PALLET AND RANGE INSTALLATION	5-6
RANGE DIMENSIONS	7
CLEARANCES	8
CONNECTION TO THE POWER SUPPLY	9
POWER CORD ROUTING	10
CONTROL KNOB AND HANDRAIL CONNECTION	11
WIRING DIAGRAM	12
AGA CITY24 CHECKLIST	13

## PRODUCT SAFETY

MEANING/DESCRIPTION	SYMBOL	SIGNIFICATION/DESCRIPTION
<p><b>WARNING/CAUTION</b></p> <p>An appropriate safety instruction should be followed or caution to a potential hazard exists.</p>		<p><b>AVERTISSEMENT</b></p> <p>Une consigne de sécurité appropriée doivent être suivies ou garde d'un danger potentiel exists.</p>
<p><b>DANGEROUS VOLTAGE</b></p> <p>To indicate hazards arising from dangerous voltages.</p>		<p><b>TENSION DANGEREUSE</b></p> <p>Pour indiquer les dangers résultant des tensions dangereuses.</p>
<p><b>PROTECTIVE EARTH (GROUND)</b></p> <p>To identify any terminal which is intended for connection to an external conductor for protection against electric shock in case of a fault, or the terminal of protective earth (ground) electrode.</p>		<p><b>TERRE DE PROTECTION</b></p> <p>Pour marquer bornes destinées à être raccordées à un conducteur de protection extérieur contre les chocs électiques en cas de défaut d'isolement, ou pour marquer la borne de la terre de protection.</p>
<p><b>HEAVY</b></p> <p>This product is heavy and reference should be made to the safety instructions for provisions of lifting and moving.</p>		<p><b>LOURD</b></p> <p>Ce produit est lourd et doit être fait référence aux consignes de sécurité relatives aux dispositions de soulever et déplacer.</p>
<p><b>DISCONNECT MAINS SUPPLY</b></p> <p>Disconnect incoming supply before inspection or maintenance.</p>		<p><b>APPAREIL À LASER DE CLASSE 2</b></p> <p>Alimentation d'entrée Débrancher avant inspection ou d'entretien.</p>
<p><b>REFER TO MANUAL</b></p> <p>Refer to relevant instructions detailed within the product manual.</p>		<p><b>ATTENTION, SURFACE TRÈS CHAUDE</b></p> <p>Reportez-vous aux instructions applicables, indiquées dans le manuel du produit.</p>

## GENERAL NOTES

**NOTE:** THESE INSTALLATION INSTRUCTIONS SHOULD BE LEFT WITH THE RANGE AND THE USER TO RETAIN FOR FUTURE REFERENCE.

## HEALTH AND SAFETY

### Consumer Protection

As responsible manufacturers we take care to make sure that our products are designed and constructed to meet the required safety standards when properly installed and used.

### PLEASE READ THE ACCOMPANYING WARRANTY

Any alteration that is not approved by AGA could invalidate the approval of the appliance, operation of the warranty and could also affect your statutory rights.

## GENERAL INSTALLATION REQUIREMENTS

The installation of the range must be in accordance with the relevant requirements of the local Wiring and Building Regulations. It should be in accordance also with any relevant requirements of the Local Authority.

In your own interest and that of safety to comply with the law, all appliances should be installed by an authorized AGA distributor in accordance with the relevant regulations.



**CAUTION:**  
**THIS UNIT IS HEAVY, PROPER EQUIPMENT AND ADEQUATE  
MANPOWER MUST BE USED IN MOVING THE RANGE TO  
AVOID DAMAGE TO THE UNIT OR THE FLOOR**

# REMOVAL FROM PALLET AND RANGE INSTALLATION

**Removing of transit brackets** - Unscrew 4 screws and remove brackets, from front and two screws from rear.

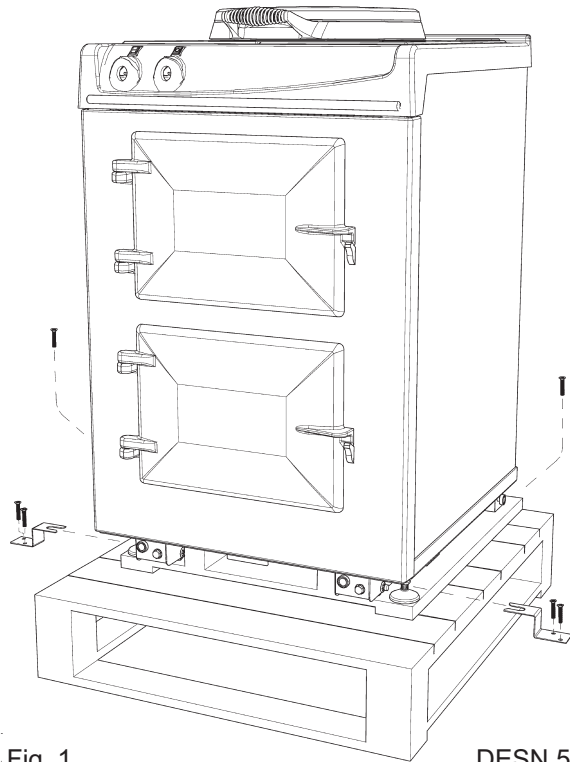
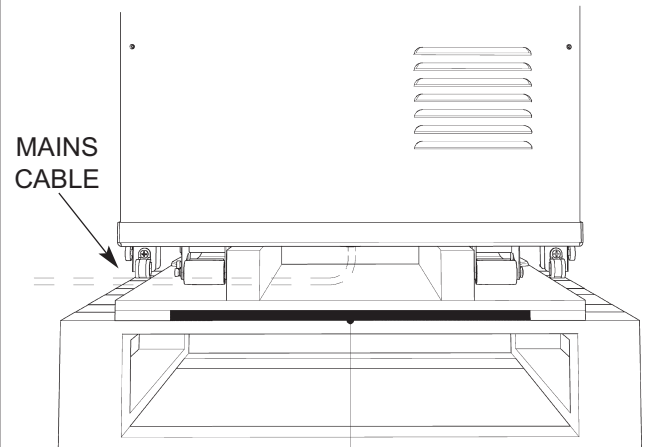

Fig. 1

DESN 516905

**NOTE:** Care must be taken not to trap power cord.



Range to be removed from rear of pallet only. Recess provided for suitable appliance dolly. Range to be secured to appliance dolly with suitable straps (shaded area)



Fig. 2

DESN 516891

Once range is in position in kitchen, remove appliance dolly and straps. The front stability feet can be raised with a 12mm open end wrench to allow appliance to be slid from transit pallet.

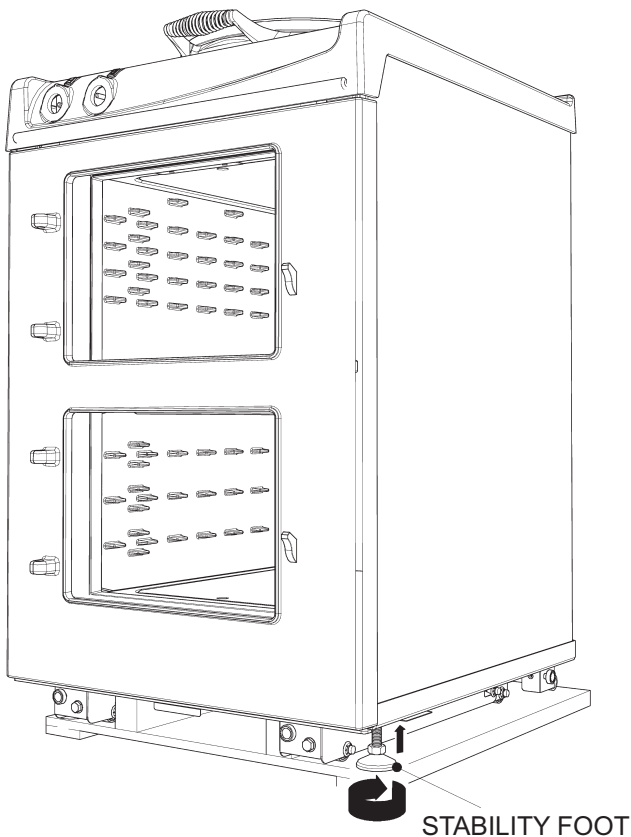

Fig. 3

DESN 516906

Slide range off transit pallet. Take care not to trap mains cable.

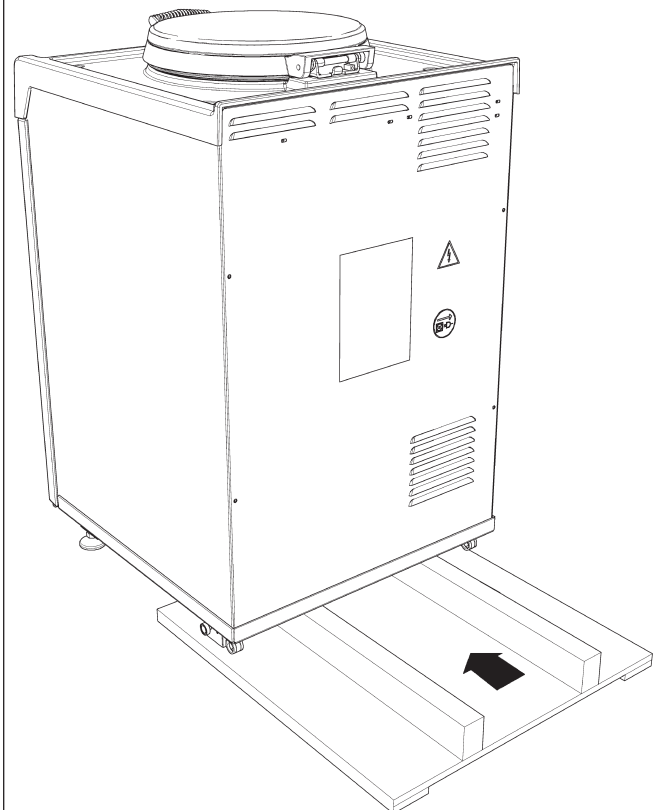

Fig. 4

DESN 516893

## REMOVAL FROM PALLET AND RANGE INSTALLATION

Range can now be pushed back on its wheels into desired position.

**NOTE:** Care must be taken not to trap mains cable.

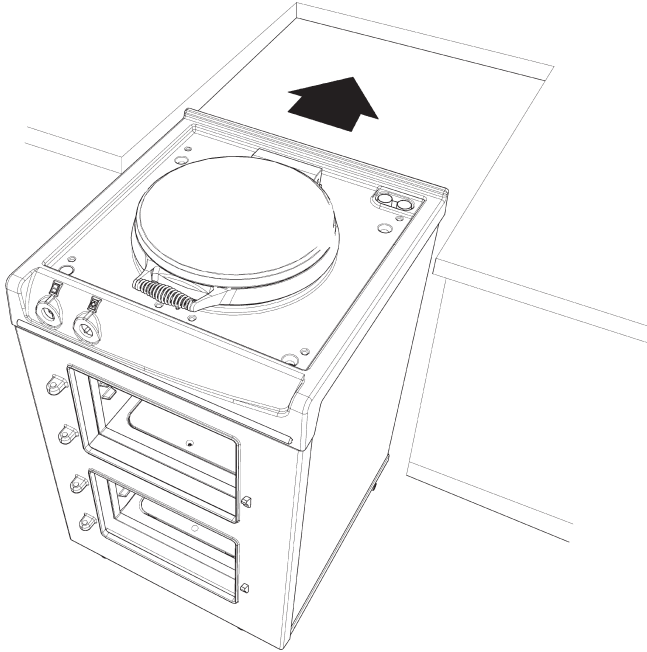
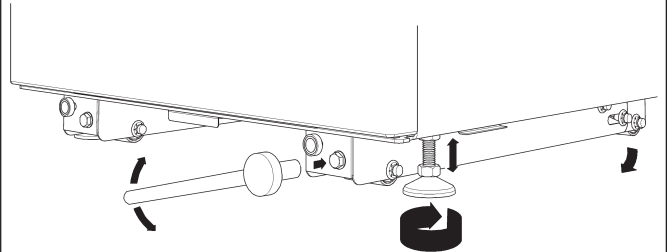

Fig. 5

DESN 516907

**Levelling of range** - Use 13mm socket to adjust wheel mechanism for **FINE** adjustment on both sides at rear of the appliance.

Using a 12mm open end wrench, feet can be adjusted at front to make **FINE** adjustments to the front of the appliance and to provide a brake for the wheels.



Turning the bolt clockwise will lower the wheel thus increasing height of the range.

Anti-clockwise lifts the wheels and lowers the range.

Fig. 6

DESN 516895

### Fitting magnetic plinth

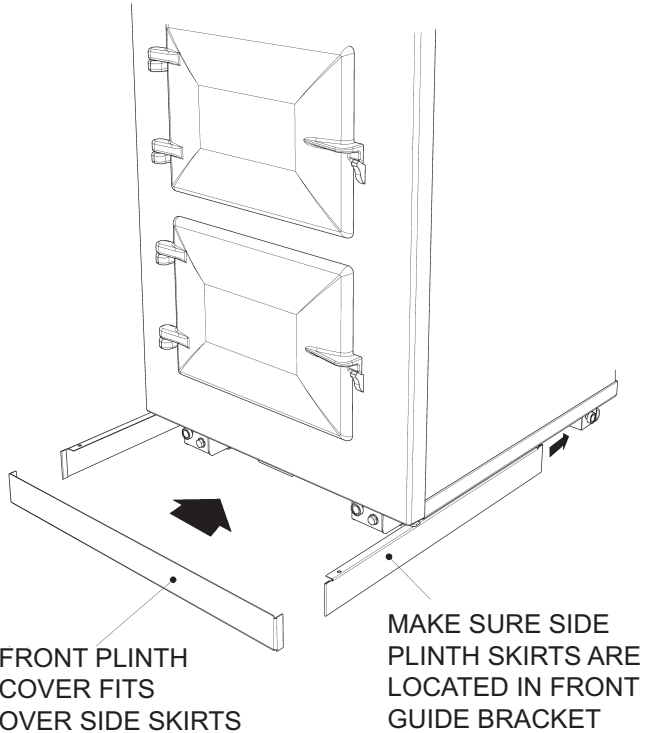

Fig. 7

DESN 516897

**Resting Plate Adjustment** - Resting plates have adjuster screw feet for setting of height and to improve stability.

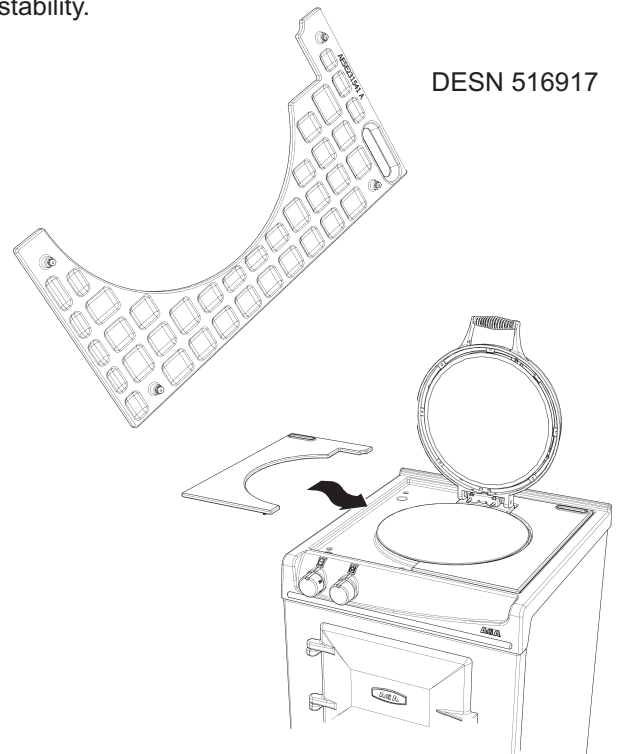

Fig. 8

DESN 516888

# RANGE DIMENSIONS - AGA CITY24

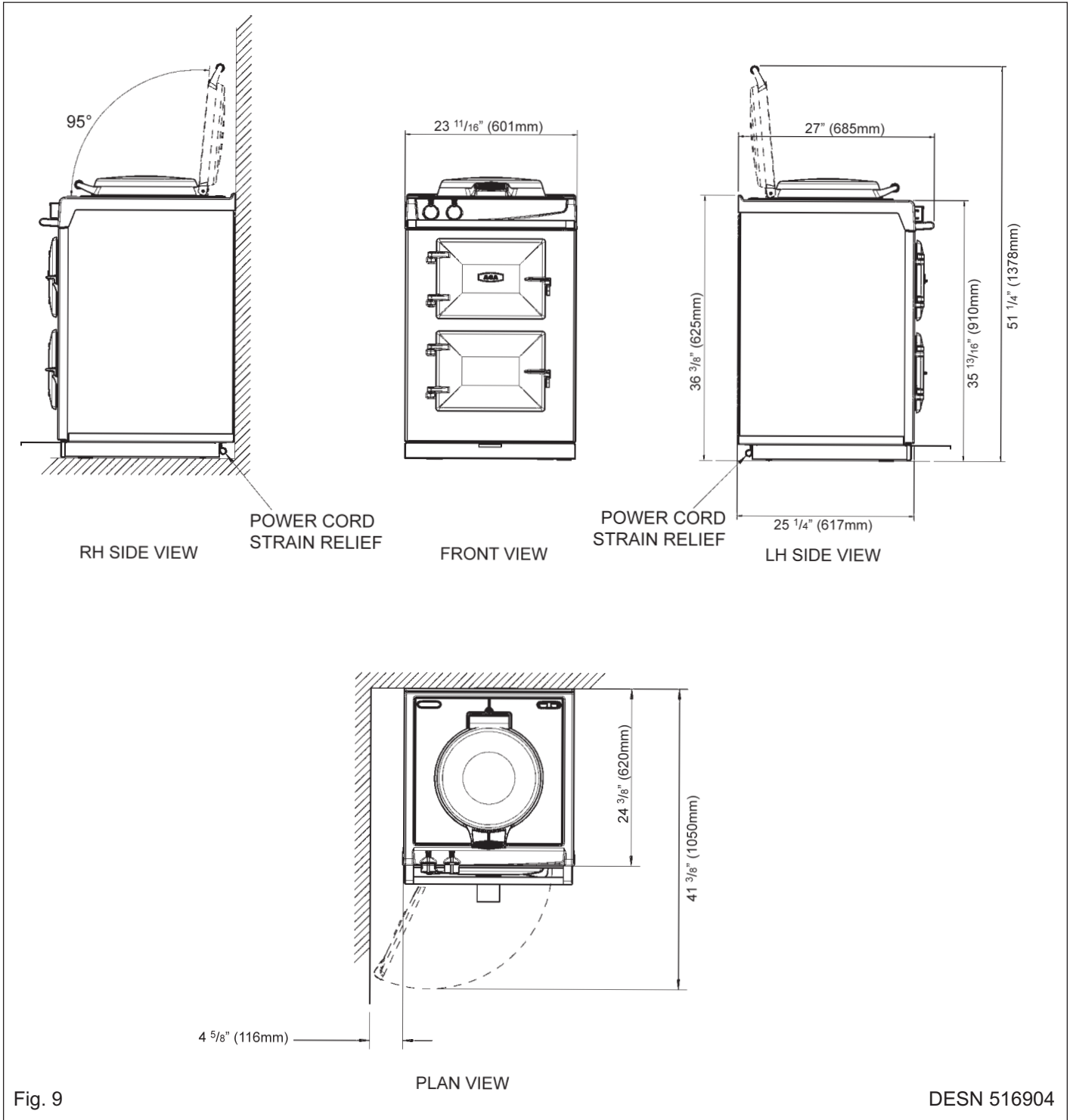

Fig. 9

DESN 516904

## Range Dimensions

When surveying for a range installation the actual clearance required for the 'body' of the range should be increased by 1/4" (6mm) beyond the figures quoted above. This allows safe margin to take into account the natural dimensional variations found in major castings. In particular the width across the range recess could be critical.

## APPLIANCE WEIGHT (Excludes Packaging)

Model: AGA CITY24 - 492lbs (223kg)

## CLEARANCES

The complete range is floor mounted and the space in which the appliance is to be fitted must have the following minimum dimensions:-

A minimum clearance of 2 <sup>3</sup>/<sub>8</sub>" (60mm) is required above the raised insulating cover handle.

### Side Clearances

A 1/8" (3mm) gap is required each side between the range top plate and adjoining work surfaces that may be fitted, this is to allow for the safe removal of the top plate should this be required at a later date.

Where ranges are fitted against side walls a 4 <sup>9</sup>/<sub>16</sub>" (116mm) clearance is required on the left hand side for oven doors access.

If the AGA is to be installed in a brick recess, then the minimum clearance should be increased by at least 1/8" (6mm), to allow for the walls not being square.

In addition, a minimum clearance of 39 <sup>5</sup>/<sub>8</sub>" (1000mm) must be available at the front of the ranges to enable the ranges to be serviced.

### Range Base or Hearth

It is essential that the base or hearth on which the range stands should be level and be capable of supporting the total weight of the appliance.

The front plinth cover is removable and must not be obstructed by flooring or tiles. If necessary the range must be raised by the thickness of the tiles to ensure the plinth can be removed, and the range can be rolled out for service.

### Tiling

When the range is to stand in a recess or against a wall which is to be tiled, under no circumstances should the tiles overlap the range top plate, access to remove the top plate must be allowed for servicing at a later date.

Since this appliance can be used continuously, please take note of these **IMPORTANT** instructions.

#### Combustible Walls

Houses constructed of combustible materials (such as all-timber or stud wall partitions and batoned plasterboarded walls) require special wall heat protection features.

Non-combustible walls behind a range must be of at least 1/4" (25mm) thick insulation board (Monolux or equivalent), up to hotplate level.

**SPECIAL NOTE:** Ensure electric cabling or plastic services do not pass within or on the outside of the wall, behind or directly above the range. This type of material can age prematurely when exposed to continuous higher ambient temperature.



## CONNECTION TO THE POWER SUPPLY



### Electric Shock Hazard



Rating Plate is located behind removable plinth, see Fig. 4.

Electrical Grounding is required on this appliance.

**DO NOT** connect to the electrical supply until the appliance is permanently grounded.

**This appliance must be connected to a grounded metallic permanent supply or a grounding connector should be connected to the grounding terminal or wire lead on the appliance.**

**Failure to follow these instructions could result in death or serious injury.**

This range must be supplied with a 240V, 60Hz power supply and connected to an individual, properly grounded branch circuit protected by a circuit breaker. At 240V, it has a maximum load of 30 amps. Electric hook-up must be done by a licensed electrician. This unit must be installed according to regional codes, or in the absence of codes, the National Electrical Code.

- Product installation requires a separate (not shared) 240V/40 amp circuit protected by an appropriate branch circuit supply.
- The power cord on your range is fitted with a standard four (4) conductor type 14-50P plug (matching receptacle 14-50R).

The method of connection to the mains electricity supply must facilitate complete electrical isolation of the appliance.

The mains connection and isolation should not be positioned above the range and must be positioned within the area defined in Fig. 11, Page 10.

**THIS RANGE MUST BE COMPLETELY ISOLATED FROM THE ELECTRICITY SUPPLY BEFORE SERVICING. THE RANGE IS DESIGNED FOR THE VOLTAGE STATED ON THE RATING PLATE, WHICH IS SITUATED BEHIND THE PLINTH COVER.**

# MAINS CABLE ROUTING

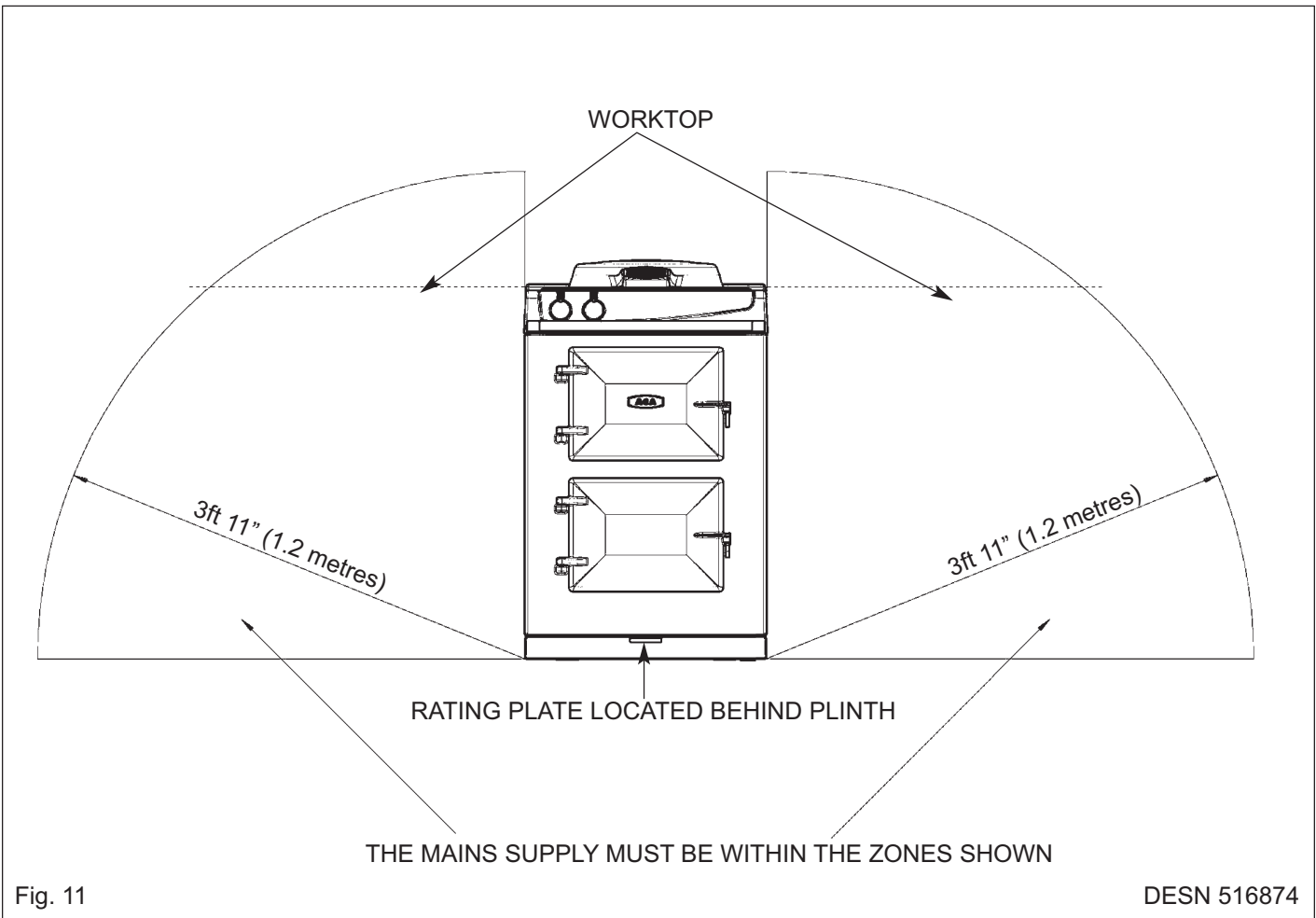
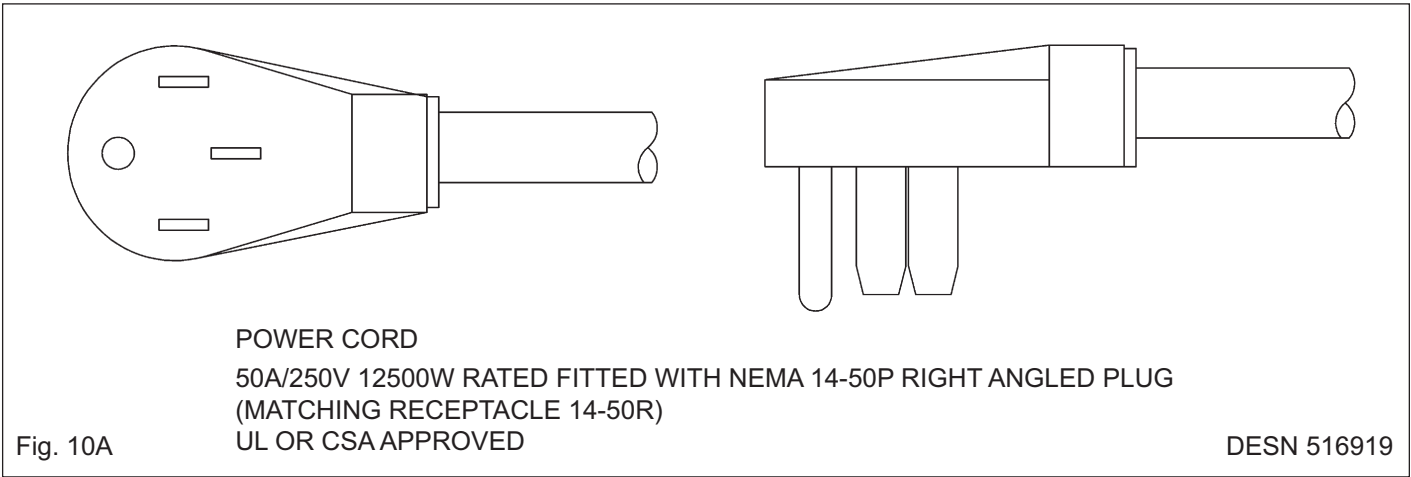
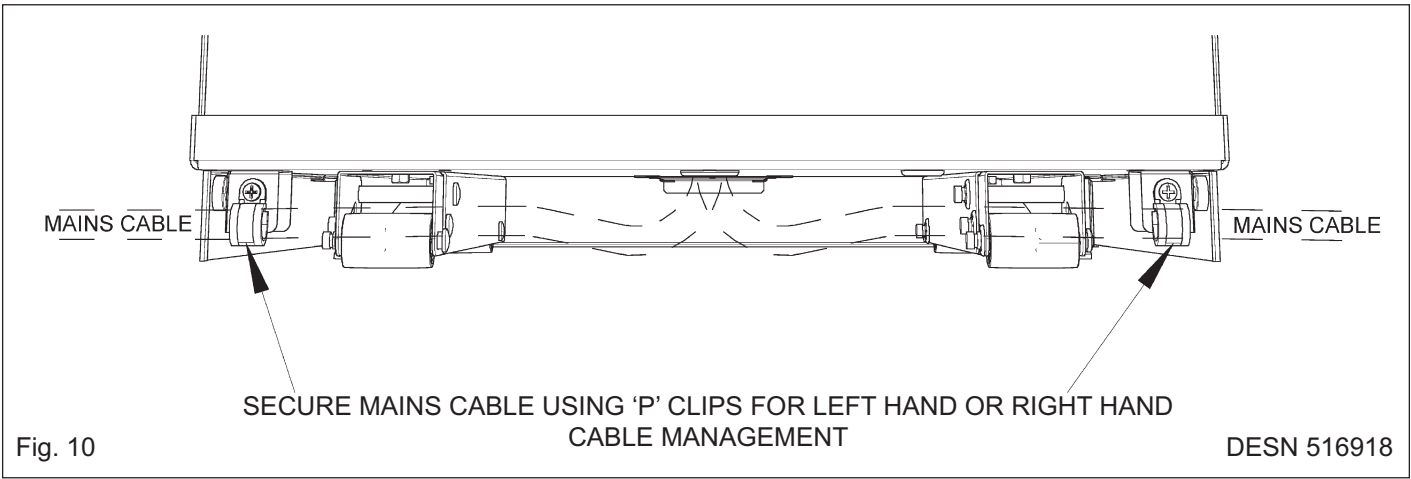

## CONTROL KNOB AND HANDRAIL CONNECTION

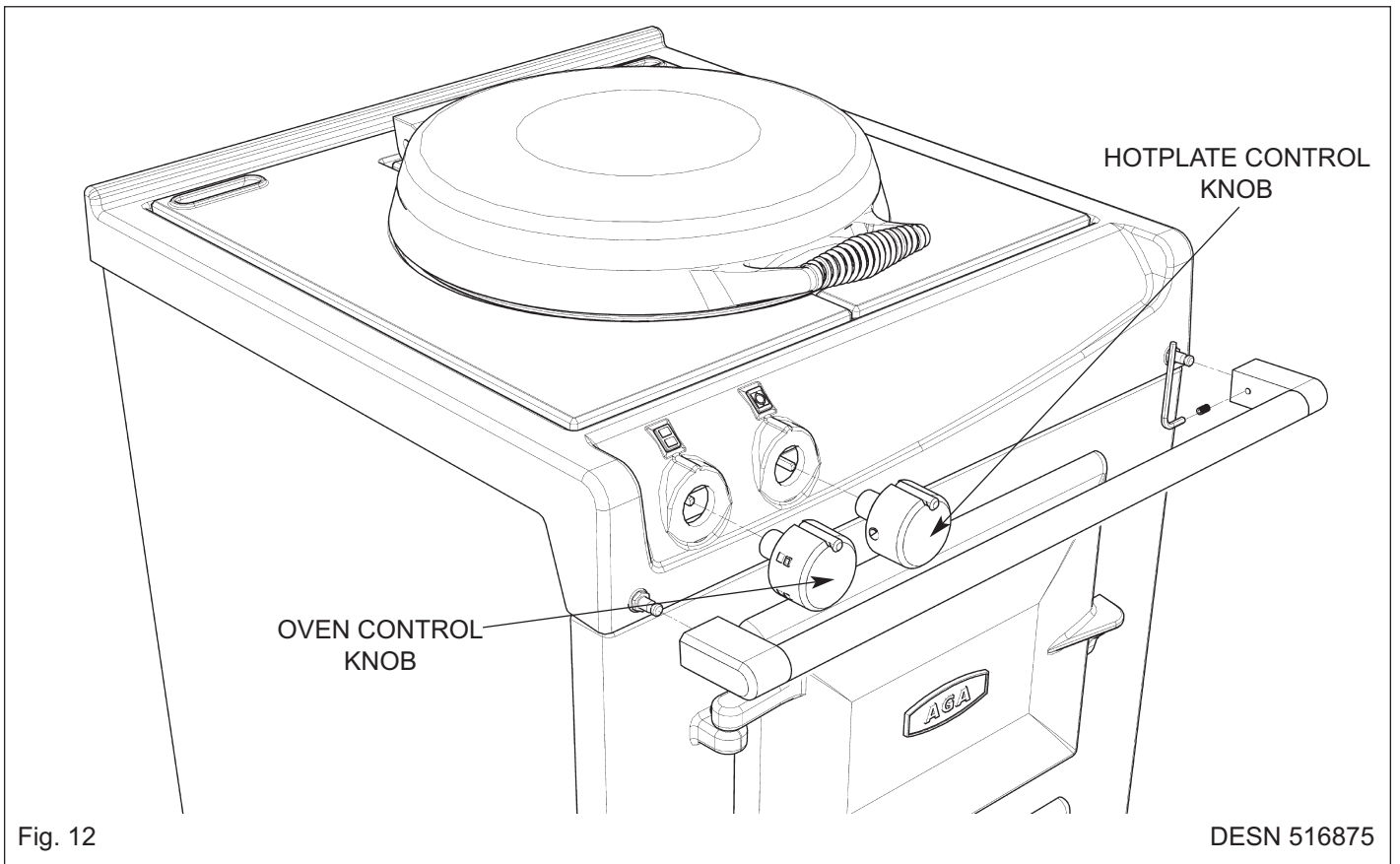

### Control Knob Location

Ensure control knobs are located onto spindles correctly, as shown in Fig 12.

### Handrail Location - AGA City24 (Traditional)

Locate handrail onto spindle, lock into position with grub screws (located on the inside of the bracket).

# WIRING DIAGRAM

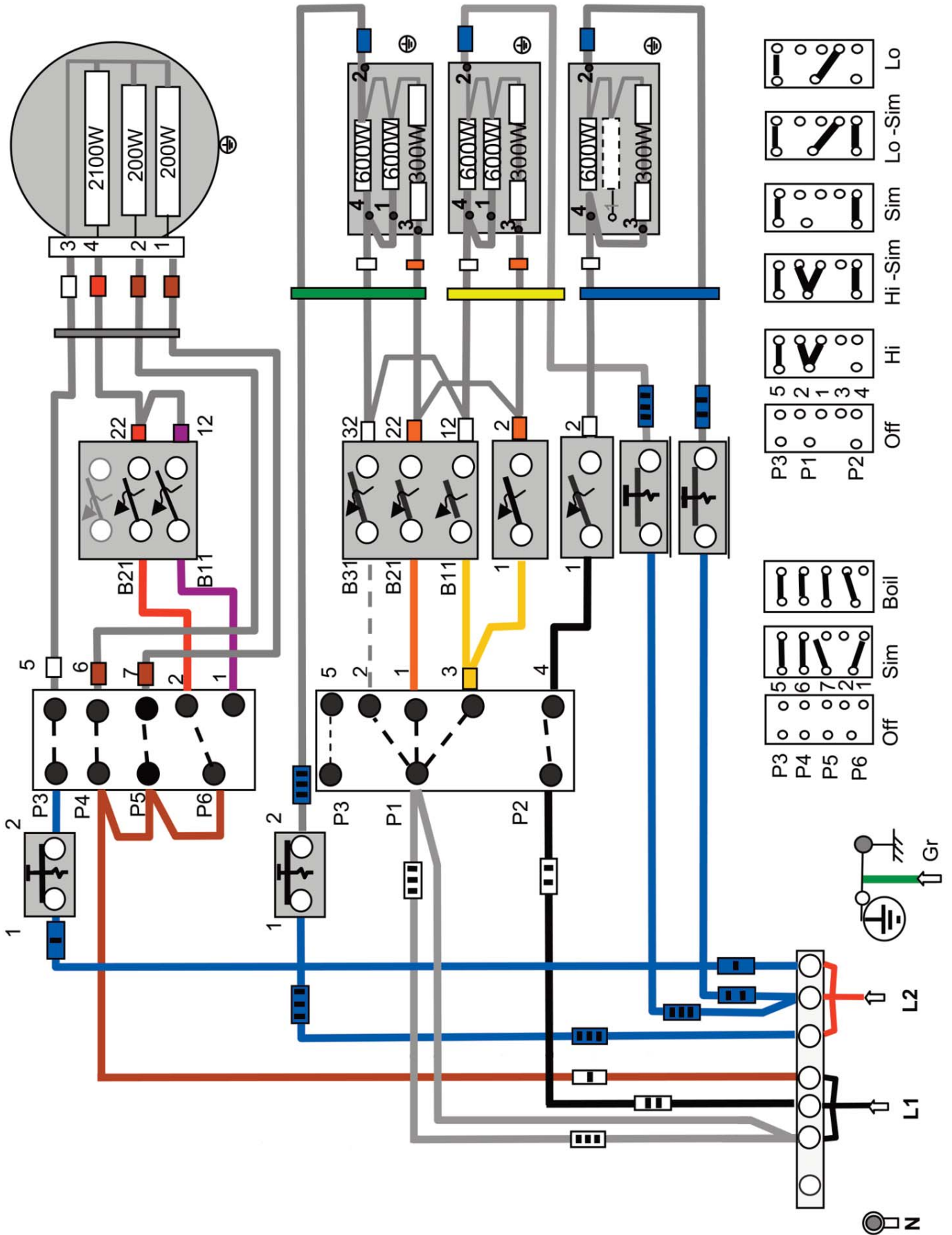

Fig. 13

# AGA CITY24 CHECKLIST

SERIAL No.

Tick Box

- Check hotplate lid and setting
- Check oven door seals, adjust door alignment if necessary.   
Slow cook oven rope seals **MUST** have a gap between the door hinges. The roasting oven is fitted with a continuous seal.
- Ensure all plastic film is removed from the inside of the oven doors.
- Turn on roasting and slow cook oven, set hotplate to simmer. Raise hotplate lid to avoid staining.
- After 30 minutes, check hotplate temperatures (approx). 
  1. Simmerspot (200 - 250°C)
  - then hotplate to boiling, after 15 minutes check temperature
  2. Hotspot (330 - 380°C)
- Guide customer through the Users Instructions of the range, offering best practices on oven maintenance, energy usage, enamel cleaning (boiled vegetable water staining on enamel etc.)

Engineer's Signature .....

Date .....





**For further advice or information contact  
your local AGA Specialist**

With AGA Marvel's policy of continuous product improvement, the Company reserves the right to change specifications and make modifications to the appliance described and illustrated at any time.



Supplied by

AGA Marvel  
1260 E. Van Deirse St.  
Greenville, MI 48838

Business (616) 754-5601  
Fax (616) 754-9690  
Toll Free Telephone 800-223-3900

[www.agamarvel.com](http://www.agamarvel.com)