

Installation
Operation
and
Maintenance
Instructions

Beverage and Wine
Refrigerator

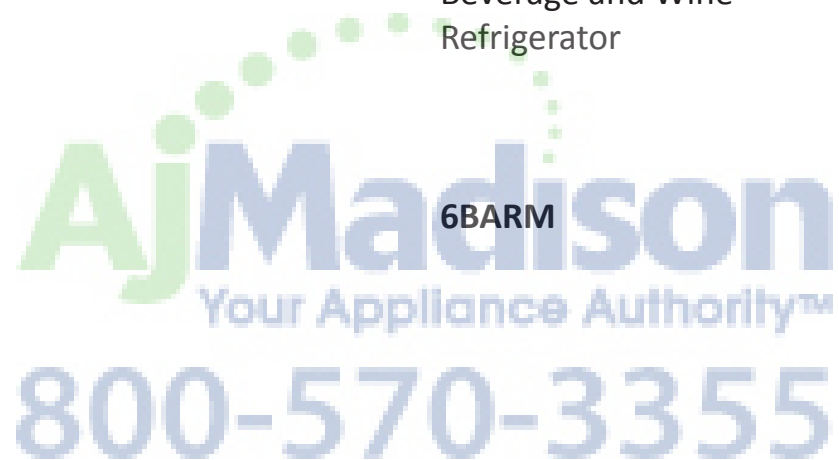

CONTENTS

Unpacking your refrigerator.....	2
Removing the packaging.....	2
Warranty Registration.....	2
Installing your refrigerator.....	3
Selecting the location.....	3
Outdoor installation.....	3
Cabinet Clearances.....	3
Leveling legs.....	3
Grounding method.....	3
Electrical Requirements.....	3
Using Your MicroSentry™ Control.....	4/5
Dimensions for 6BARM glass door.....	6
Recommended Rough in Opening Dimensions	
for 6BARM glass door.....	6
6BARM Features.....	7
Door Alignment	8
Care and Cleaning.....	9
Cleaning condenser air flow.....	9
Cleaning the cabinet.....	9
Cleaning the interior.....	9
Cleaning the shelves.....	9
Cleaning the door gasket.....	9
Replacing the light bulb.....	9
Troubleshooting Guide.....	10
Obtaining Service.....	11
Household Product Warranty.....	12
Appendix A additional MicroSentry™ features.....	13

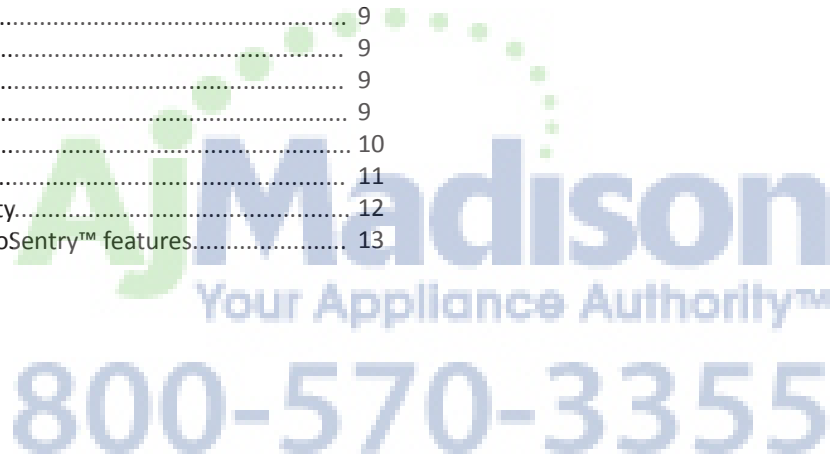

AGA MARVEL is committed to building a quality product in an environmentally friendly manner. Our processes are tightly controlled and closely monitored. We have achieved certifications in ISO 9001 for quality assurance and ISO 14001 for environmental management from Lloyd's Register Quality Assurance.



UNPACKING YOUR BEVERAGE AND WINE REFRIGERATOR

Important Safety Instructions

Warnings and safety instructions appearing in this guide are not meant to cover all possible conditions and situations that may occur. Common sense, caution, and care must be exercised when installing, maintaining, or operating this appliance.

Recognize Safety Symbols, Words, and Labels.



CAUTION-Hazards or unsafe practices which could result in personal injury or property or product damage.



WARNING-Hazards or unsafe practices which could result in personal injury.



NOTE-Important information to make a problem free installation.

Note to Customer

This merchandise was carefully packed and thoroughly inspected before leaving our plant. Responsibility for its safe delivery was assumed by the retailer upon acceptance of the shipment. Claims for loss or damage sustained in transit must be made to the retailer.

DO NOT RETURN DAMAGED MERCHANDISE TO THE MANUFACTURER - FILE THE CLAIM WITH THE RETAILER.



If the unit was shipped or has been laying on its back for any period of time allow the refrigerator to sit upright for a period of at least 24 hours before plugging in. This will assure oil returns to the compressor. Plugging the refrigerator in immediately may cause damage to internal parts.

Warranty Registration

It is important you send in your warranty registration card immediately after taking delivery of your refrigerator or you can register online at www.agamarvel.com.

The following information will be required when registering your unit.

- Model Number
- Serial Number
- Date of Purchase
- Dealers name and address

The model number and serial number can be found on the serial plate which is located inside the refrigerator on the left side toward the top of the liner.



Help Prevent Tragedies

Child entrapment and suffocation are not problems of the past. Junked or abandoned refrigerators are still dangerous - even if they sit out for "just a few days".

If you are getting rid of your old refrigerator, please follow the instructions below to help prevent accidents.

Before you throw away your old refrigerator or freezer:

- Take off the doors or remove the drawers.
- Leave the shelves in place so children may not easily climb inside.

Remove Packaging

Your refrigerator has been packed for shipment with all parts that could be damaged by movement securely fastened. Cut the banding material at the bottom of the carton, unfold the cartoning at the bottom and remove the carton from the appliance. Remove the plastic bag, styrofoam corner posts, and any tape holding the door closed and internal components in place. The owners manual is shipped inside the refrigerator in a plastic bag along with the warranty registration card.

Important

Keep your carton packaging until your refrigerator has been thoroughly inspected and found to be in good condition. If there is damage, the packaging will be needed as proof of damage in transit. Afterwards please dispose of all items responsibly in particular the plastic bags which can be a suffocation hazard.

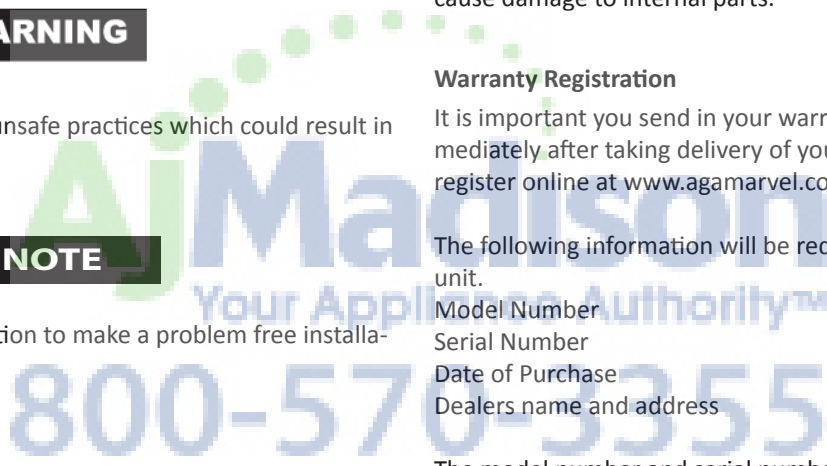

INSTALLING YOUR BEVERAGE AND WINE REFRIGERATOR

Select Location

The proper location will ensure peak performance of your appliance. We recommend a location where the unit will be out of direct sunlight and away from heat sources. To assure your product performs to specifications the recommended installation location temperature range is from 65 to 80°F (18 to 27°C) for indoor built in units, 65 to 90°F (18 to 32°C) for indoor freestanding units.

Cabinet Clearance

Ventilation is required from the bottom front section of the unit. Keep this area open and clear of any obstructions. Adjacent cabinets and counter top can be installed around the unit as long as the grille and door access remain unobstructed.

Front Grille

Do not obstruct the front grille. The openings within the front grille provide air to flow into and exit from the refrigerator condenser. For this reason it is important this area to not be obstructed and be kept clean. AGA MARVEL does not recommend the use of custom made grilles as air flow may be restricted because of inadequate openings. (See Figure 1).

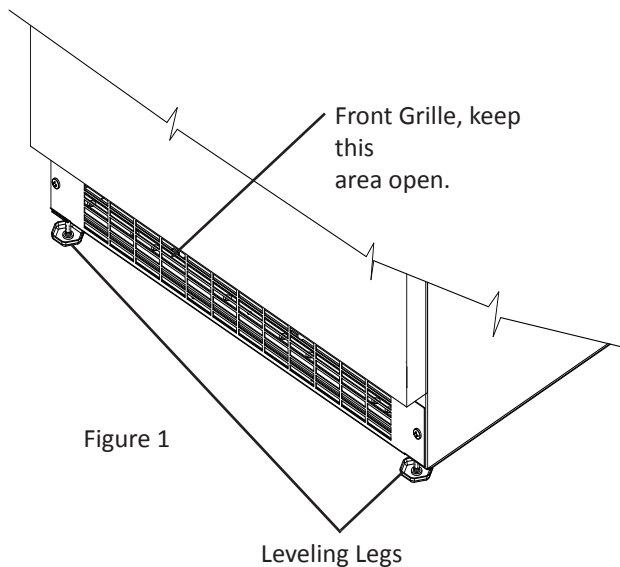

Leveling Legs

Adjustable legs at the front and rear corners of the unit should be set so the unit is firmly positioned on the floor and level from side to side and front to back. Turn leveling legs clockwise to raise unit, counterclockwise to lower it. (See Figure 1).

⚠ CAUTION

- Do not splash or spray water from a hose on the refrigerator. Doing so may cause an electrical shock, which may result in severe injury or death.
- This unit should not, under any circumstances, be ungrounded.

Grounding Method

This product is factory equipped with a power supply cord that has a three-pronged, grounded plug. It must be plugged into a mating grounding type receptacle in accordance with the National Electrical Code and applicable local codes and ordinances (see Figure 2). If the circuit does not have a grounding type receptacle, it is the responsibility and obligation of the customer to exchange the existing receptacle in accordance with the National Electrical Code and applicable local codes and ordinances. The third ground prong should not, under any circumstances, be cut or removed.

Electrical Connection

115 volts, 3.3 amps running max. A 15 amp dedicated circuit is required. A 3 prong grounded receptacle is required.

⚠ CAUTION

Do not use an extension cord with this appliance.

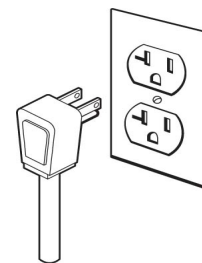

USING YOUR MicroSentry™ REFRIGERATOR CONTROL

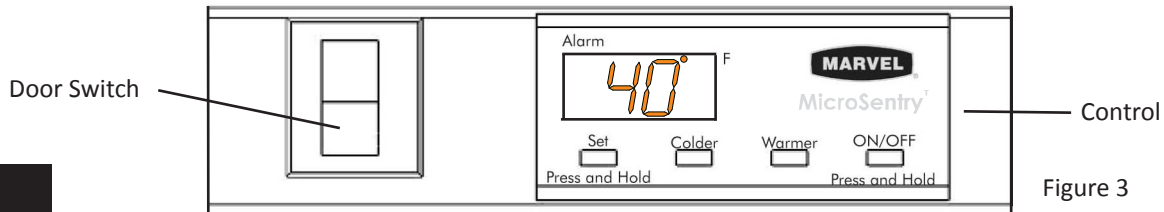

Figure 3

NOTE

During initial startup, or anytime power is interrupted, there will be an approximate 5 minute delay before the refrigerator starts. During this period the controller will be assessing the temperature in the refrigerator and the display will appear erratic, this is normal. The desired temperature set point can be programmed during this start up period.

Starting your refrigerator

The refrigerator will begin start up when initially plugged in or when power resumes after a power outage. At this time the refrigerator will take approximately 5 minutes to begin running as noted above. If the refrigerator has been turned off during use, "OFF" will appear on the display. To start the refrigerator from the "OFF" position press and hold the ON/OFF button for three seconds.

Set temperature

To set temperature set point, press and continue to hold "SET" button. After one second, set point will be displayed. While holding "SET" button use the "WARMER" or "COLDER" button to desired set point.

NOTE: Momentarily pressing & releasing "SET" button will access information menu of control. Refer to appendix A for information on this feature.

Refrigerator operation

The available temperature range for the 6BARM refrigerator is 39° to 65°F (4° to 18°C).

It may take up to 24 hours for your refrigerator to reach desired temperature. This will depend on amount of contents loaded and number of openings and closings of the door.

For best results allow refrigerator to "pull down" to desired set point before loading. Once contents are loaded, allow at least 48 hours for temperature to stabilize before making any adjustments to the set point.

Alarms

Your MicroSentry™ refrigerator control will monitor refrigerator function and alert you with a series of audible and visual alarms.



- **Door Ajar Alarm:** If the door has been left open for over five (5) minutes, the alarm will sound in one (1) second intervals. The display panel will flash "do" and the LED light will be a steady amber color. This will stop as soon as the door is closed.



- **High and Low Temperature Alarm:** If your unit reaches an unacceptable temperature outside of your set point, the alarm will sound in one (1) second intervals. The display panel will flash either "hi" or "Lo" depending upon the condition and the LED light will be a steady amber color. "hi" indicates that the temperature is 10° F (5.5°C) above the set point and "Lo" indicates that the temperature is 10° F (5.5°C) below the set point. The alarm will remain active until the condition is corrected.

NOTE: During initial appliance start-up, the high temperature alarm may sound until the interior temperature reaches set point.



- **Temperature Sensor Fault:** If the controller detects that the temperature sensor is not properly functioning, a temperature sensor alarm will sound. "E1" will flash on the display, and an alarm will sound. Please call AGA MARVEL Customer Service or your dealer if this error code is displayed.



- **Condenser Needs Cleaning:** When the refrigerator has reached the recommended amount of run time to necessitate cleaning the air flow, "cl" will flash on the display as a reminder. See the "Care and Cleaning" section for cleaning instructions.

To clear the alarm:

1) Press and release the "SET" button four times.



- "cnd" will be displayed on the screen.
- 2) While "cnd" is displayed, press and hold the "SET" button. The display will show the number of weeks the refrigerator has been running.
 - 3) While holding the "SET" button, press and release the ON/OFF button. The number shown on the display will reset to 0.
 - 4) Release the "SET" key.

Alarm Mute

Press any key to mute the audible portion of an alarm.

NOTE-This action will only mute the alarm. If the condition that caused the alarm continues, the alarm code will continue to flash and will sound for 20 seconds every 60 minutes.

USING YOUR MicroSentry™ REFRIGERATOR CONTROL

Turning Refrigerator Off

To turn refrigerator off, press and hold "ON/OFF" button for

three (3) seconds. "OFF"  will appear on the display.

Additional MicroSentry™ Features

Refer to Appendix A for details on additional features available.



DIMENSIONS FOR 6BARM GLASS DOOR

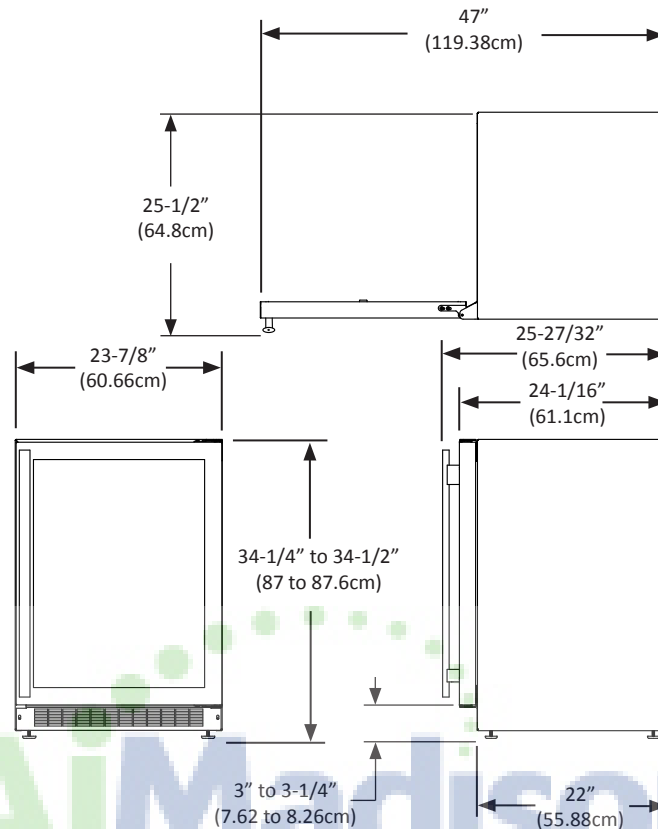

ROUGH IN OPENING DIMENSIONS FOR 6BARM GLASS DOOR

800-570-3355

⚠ CAUTION

Electrical Requirements: 115 volts, 3.3 amps running max. A 15 amp dedicated circuit is required. A 3 prong grounded receptacle is required.

Power outlet can be located in the back wall behind unit. Add 1" to depth for thickness of plug, or recess outlet 1" into the wall. Power outlet can also be installed in adjacent cabinetry with a cutout for routing of power cord. Follow all local building codes when installing electrical and unit. Product weight = 130 lbs. (59.1 kg.)

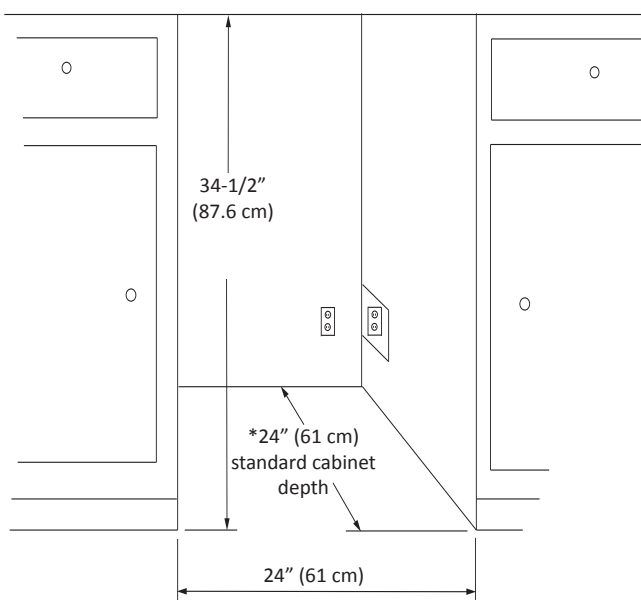

* Depth dimension may vary depending on each individual installation.

6BARM BEVERAGE AND WINE REFRIGERATOR FEATURES

Loading Tips and Suggestions

The wine rack pull-out shelf holds eight (8) bottles. See Figure 4 and Figure 6 for typical wine bottle orientation. The wine rack is located at the bottom of the cabinet just above the fixed wooden bottle cradle which will store 6 bottles of wine. The glass and metal shelves and fixed position wire rack are for general beverage storage, such as beer and soft drinks. The glass shelf also acts as a zone separator to create a warmer zone (5° - 8°F) for wine storage. To cool your wine to the same temperature as set point, the glass can be removed and if necessary replaced with a second metal shelf. Opened wine bottles and tall beverage containers may be stored on the black metal shelf closest to the cabinet top, on the right side where there is clearance for the bottles and/or containers to stand upright. (See Figure 5).

The wooden, bottom bottle cradle may be removed for storing "jug" wines. Just remove the two (2) screws that secure the cradle to the cabinet floor.

You may store magnums and other large bottles on any of the racks (except for the top rack) by removing the rack directly above them. Position white wines on the middle or lower racks and red wines on the upper racks (see Figure 6).

The bottles on the top rack directly under the light will be exposed to a slightly higher temperature when the light is on. Position your wines accordingly and REMEMBER TO TURN OFF THE LIGHT WHEN IT IS NO LONGER NEEDED.

Keep wines that you plan to use for everyday drinking and entertaining on the front half of the racks where labels are completely visible. Place wines for aging or longer term storing in the rear.

Pull-out Rack

The pull-out wine rack may be pulled out approximately seven and a half (7.5) inches to facilitate adding or removing bottles. Do NOT lean on or press down heavily on the wine shelf. Doing so may damage the shelf and the wine bottles stored on it. Pull the wine rack out gently and carefully to minimize unsettling your wine collection.

Single Bottle Racks

Since bottles are not stacked on top of each other, you can easily view and access your inventory without disturbing other bottles (see Figure 6).

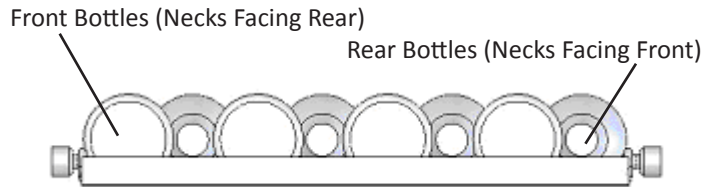

Figure 4

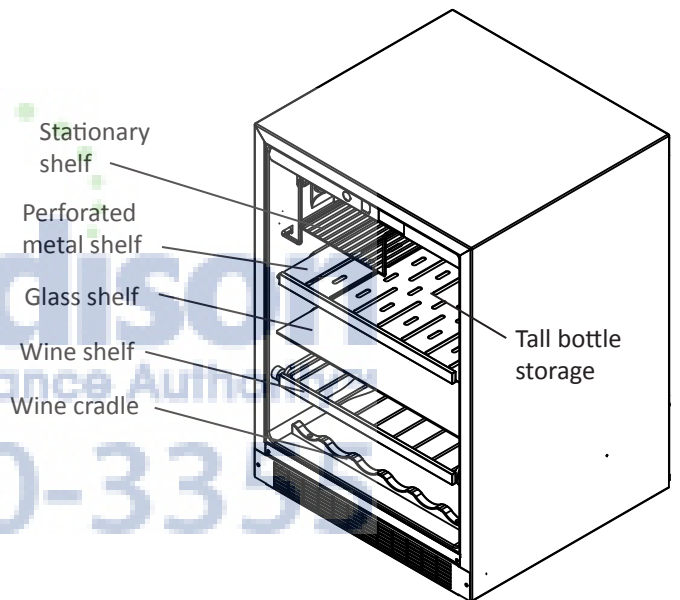

Figure 5

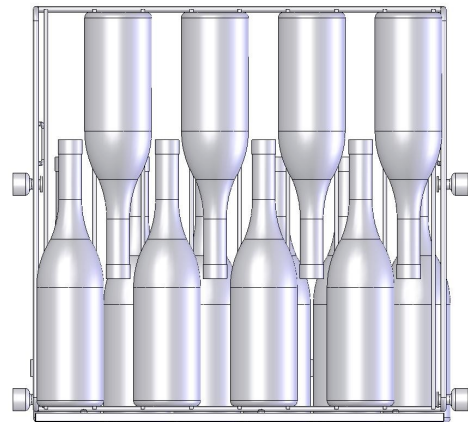

Figure 6

Door Alignment Procedure

The door should be parallel to the sides and top of the refrigerator. If alignment is necessary the door may be adjusted by loosening the 2 screws which secure the hinge adapter brackets to the door and adjusting the door side to side. Use a 5/32" allen wrench for this procedure. (See Figure 7 below).

NOTE

NOTE: For door closer to work properly it is necessary to maintain a minimum space of 9/32" (7.1mm) between door and cabinet flange as shown. This space can be adjusted by adjusting the top and bottom hinge adapter.

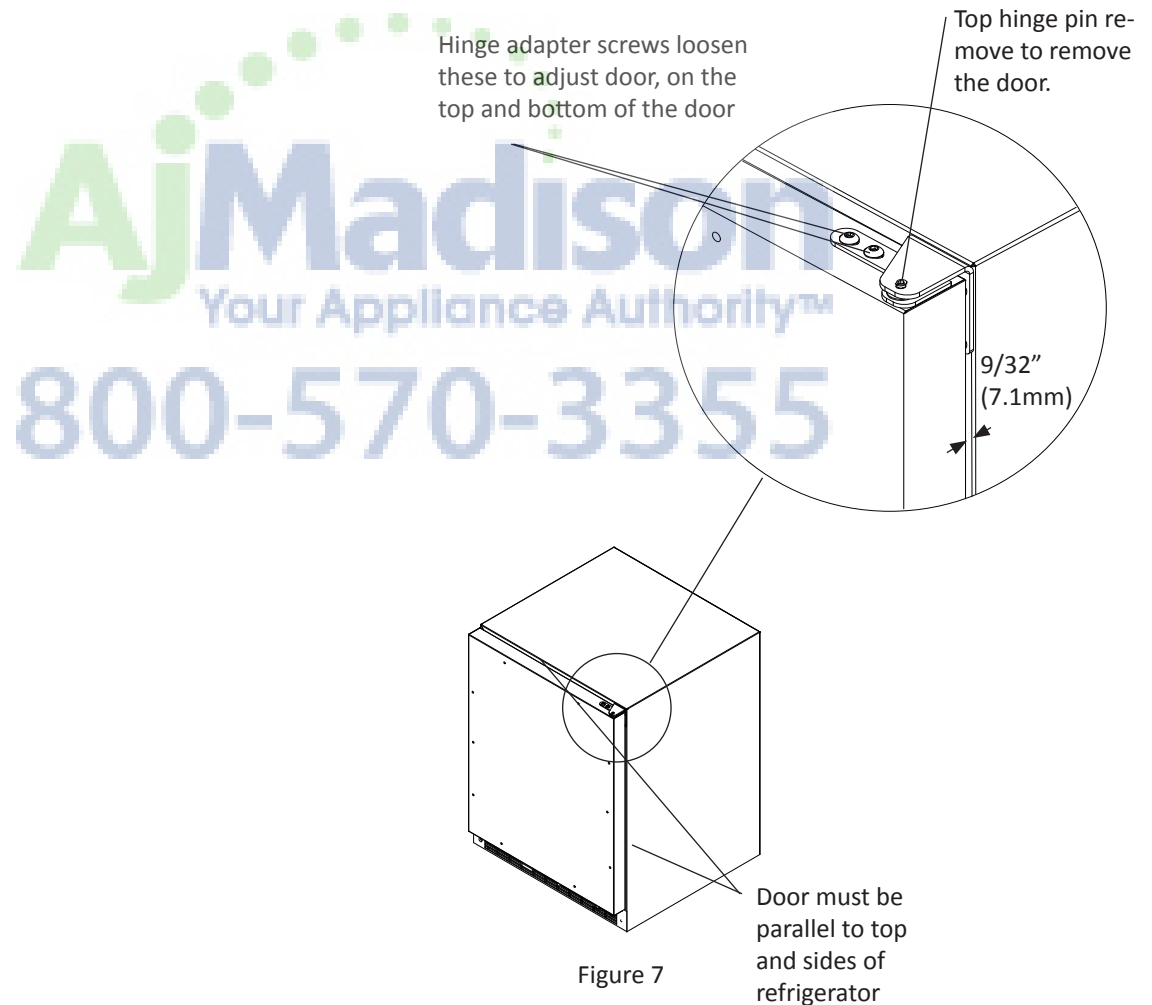

CARE AND CLEANING OF YOUR BEVERAGE AND WINE REFRIGERATOR

Condenser

The condenser tubing inside the cabinet does not require frequent cleaning; however, satisfactory cooling depends on adequate ventilation over the coils. Be sure that nothing obstructs the required air flow openings in front of the cabinet. At least once or twice a year, brush or vacuum lint and dirt from the front grille area (see page 3).

Cabinet

The painted cabinet can be washed with mild soap and water and thoroughly rinsed with clear water. NEVER use abrasive scouring cleaners.

Interior

Wash interior compartment with mild soap and water. Do NOT use an abrasive cleaner, solvent, polish cleaner or undiluted detergent.

Pull-out Racks

The racks may be cleaned with mild soap and water and a soft cloth. Do NOT use any abrasive cleaners.

Glass Door

Use a glass cleaner or mild soap and water and soft cloth to clean the glass door model. Do NOT use any abrasive cleaners.

Door Gasket

The vinyl gasket may be cleaned with mild soap and water, a baking soda solution or a mild scouring powder.

Light Bulb Replacement

WARNING

DISCONNECT THE POWER CORD BEFORE ATTEMPTING LIGHT BULB REPLACEMENT. Failure to do so may result in an electrical shock that could severely injure you.

The 6BARM uses one, 15 watt incandescent light bulb to illuminate the interior of the refrigerator. The light bulb is a very reliable electrical component, but should it not function properly, please call the dealer where you purchased your refrigerator from for a replacement light bulb. Use only an original equipment light bulb from your dealer or AGA MARVEL.

Do NOT under any circumstance use a light bulb that exceeds 15 watts!

To replace the light bulb, disconnect power to the unit. Unscrew the old light bulb located behind the display housing at the top

of the unit. Set the old light bulb aside. Screw the new light bulb into place. Reconnect power to the unit. Check to see if the light bulb operates properly to complete the installation.

The light bulb is not covered by your warranty. A replacement bulb can be obtained from your dealer or from AGA MARVEL.

In the Event of a Power Failure

If a power failure occurs, try to correct it as soon as possible. Minimize the number of door openings while the power is off so as not to adversely affect the unit's temperature.

NOTE: If a power interruption occurs, the unit may take 5 to 10 minutes to restart.



TROUBLESHOOTING YOUR BEVERAGE AND WINE REFRIGERATOR

Before You Call for Service

If the unit appears to be malfunctioning, read through this manual first. If the problem persists, check the troubleshooting guide below. Locate the problem in the guide and refer to the cause and its remedy before calling for service. The problem may be something very simple that can be solved without a service call. Some remedies listed in the Troubleshooting Guide are very complex. Consulting or contracting a qualified service technician may be necessary.

WARNING

Electrocution Hazard - Never attempt to repair or perform maintenance on the unit until the main electrical power has been disconnected.

Problem	Possible Cause	Remedy
Unit not cold enough.	<ul style="list-style-type: none"> • Control set too warm. • Airflow to front grille blocked. • Excessive usage or prolonged drawer openings. • Door gasket not sealing properly. 	<ul style="list-style-type: none"> • Adjust temperature colder. (See “Set Temperature” on page 4). Allow 24 hours for temperature to stabilize. • Airflow must not be obstructed to front grille. See “clearances” on page 3. • Allow temperature to stabilize for at least 24 hours. • Adjust or replace door gasket.
Unit too cold.	<ul style="list-style-type: none"> • Control set too cold. 	<ul style="list-style-type: none"> • Adjust temperature warmer. (See page 4, “set temperature”). Allow 24 hours for temperature to stabilize.
No interior light.	<ul style="list-style-type: none"> • Failed light bulb. 	<ul style="list-style-type: none"> • Replace light bulb, see page 18.
Light will not go out when door is closed.	<ul style="list-style-type: none"> • Door not activating light switch. 	<ul style="list-style-type: none"> • Unit not level, level unit, (See page 3, “leveling legs”) • Verify the door is aligned properly, refer to page 8 for instructions.
Noise or Vibration.	<ul style="list-style-type: none"> • Unit not level. 	<ul style="list-style-type: none"> • Level unit, see “Leveling Legs” on page 3.
Unit will not run.	<ul style="list-style-type: none"> • Unit turned off. • Power cord not plugged in. • No power at outlet. 	<ul style="list-style-type: none"> • Turn unit on. See “Starting your refrigerator” on page 4. • Plug in power cord. • Check house circuit.

HOW TO OBTAIN SERVICE

If Service is Required:

- If the product is within the first year warranty period please call AGA MARVEL Customer Service at 800.223.3900 for directions on how to obtain warranty coverage in your area.
- If the product is outside the first year warranty period, AGA MARVEL Customer Service can provide recommendations of service centers in your area. A listing of authorized service centers is also available at www.agamarvel.com under the service and support section.
- In all correspondence regarding service, be sure to give the model number, serial number, and proof of purchase.
- Try to have information or description of nature of the problem, how long the unit has been running, the room temperature, and any additional information that may be helpful in quickly solving the problem.
- Fill in pertinent information below regarding your product for future reference.

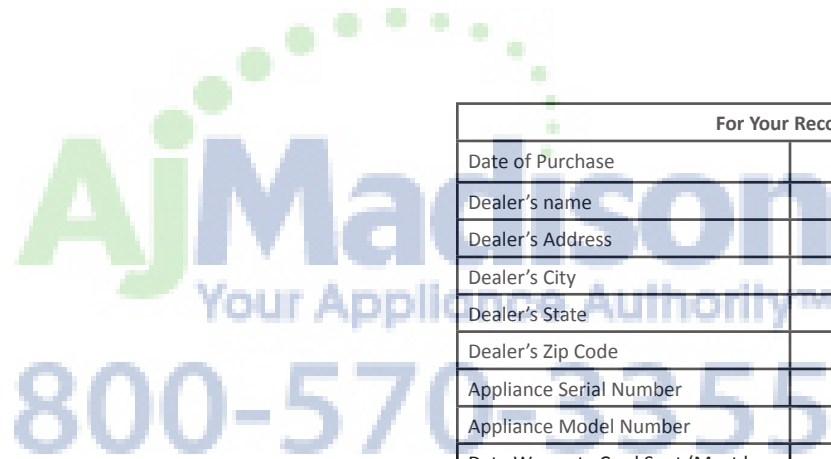

For Your Records	
Date of Purchase	
Dealer's name	
Dealer's Address	
Dealer's City	
Dealer's State	
Dealer's Zip Code	
Appliance Serial Number	
Appliance Model Number	
Date Warranty Card Sent (Must be within 10 days of purchase).	

HOUSEHOLD PRODUCT WARRANTY

Entire Product

Limited One Year Parts and Labor Warranty

AGA MARVEL warrants that it will supply all necessary parts and labor to repair or replace in the end user's home or office, any component which proves to be defective in material or workmanship, subject to the condition and exclusions stated below, for a period of one year from the date of purchase by the end user.

Additional Second Through Fifth Year

Limited Parts Only Warranty

During the four years following expiration of the one year limited warranty, AGA MARVEL will supply replacement parts for the hermetically sealed refrigeration system which consists of the compressor, condenser, drier, accumulator, bypass valve, connecting tubing and the evaporator that are proven to be defective due to workmanship or materials subject to the conditions and exclusions below.

The above warranties do not cover:

- Shipping costs of replacement parts or returned defective parts.
- Customer education or instructions on how to use the appliance.
- Any content loss due to product failure.
- Removal or installation of product.

Nor do the above warranties cover failure of this product or its components due to:

- Transportation or subsequent damages.
- Commercial use or use other than normal household or small office.
- Improper installation, misuse, abuse, accident or alteration, use of wiring not conforming to electrical codes, low or high voltages, failure to provide necessary maintenance, or other unreasonable use.
- Parts or Service Not Supplied or Designated by AGA MARVEL.

The above warranties also do not apply if:

- The original bill of sale, deliver date, or serial number cannot be verified.
- Defective parts are not returned for inspection if so requested by AGA MARVEL.
- The refrigeration equipment is not in the possession of the original end use purchaser.

The warranties set forth herein are the only warranties extended by AGA MARVEL. Any implied warranties, including the implied warranty of merchantability, are limited to the duration of these express warranties. In no event shall AGA MARVEL be liable for any consequential or incidental damages or expenses resulting from breach of these or any other warranties, whether express or implied.

Some states do not allow the exclusion or limitation of consequential damages or a limitation on how long an implied warranty lasts, so the above exclusion or limitation may not apply to you. This warranty gives you specific legal rights and you may have other rights that may vary from state to state.

No person, firm, or corporation is authorized to make any other warranty or assume any other obligation for AGA MARVEL. These warranties apply only to products used in any of the fifty states of the United States and the District of Columbia.

To obtain performance of this warranty, report any defects to:

AGA MARVEL
P.O. Box 400
1260 E. VanDeinse St.
Greenville MI 48838

Phone: 800.223.3900



APPENDIX A, ADDITIONAL MicroSentry™ FEATURES

Information Menu:

The following features are available on the Information Menu.

- Current Temperature
- Maximum Stored Temperature
- Minimum Stored Temperature
- Total Operating Time Of The Condenser
- Keypad Lockout

To access the Information Menu Press “SET” button momentarily and release.

Once in the information menu, the WARMER and COLDER keys may be used to scroll through the information menu. Additionally, pressing and releasing the SET key will advance the information menu.

The information menu will automatically exit after several seconds with no key presses.



Current Interior Temperature (ti): Press and hold the “SET” key to display the current interior temperature.



Maximum Stored Temperature (thi): Maximum stored temperature is the maximum temperature refrigerator has achieved since temperature set point was entered. Press and hold the “SET” key to display the maximum temperature stored. The data can be cleared by pressing “SET” and “ON/OFF” simultaneously while the value is displayed. NOTE: It is normal for refrigerator temperature to fluctuate from set point by several degrees.





Minimum Stored Temperature (tLO): Minimum stored temperature is the minimum temperature refrigerator has achieved since temperature set point was entered. Press and hold the “SET” key to display the minimum temperature stored. The data can be cleared by pressing “SET” and “ON/OFF” simultaneously while the value is displayed. NOTE: It is normal for refrigerator temperature to fluctuate from set point by several degrees.



Total Operating Time of the Condenser Since the Last Cleaning (cnd): Press and hold the “SET” key to display the total operating hours of the compressor since the last cleaning. The control stores the total operating hours of the compressor to determine the volume of air that has moved across the condenser coils. This number is displayed in weeks. A reminder is displayed when a cleaning is recommended (see Alarm Codes). The recommended cleaning period is the equivalent of one year of air volume. The data can be cleared by pressing the “SET” and “ON/OFF” keys simultaneously while the value is displayed.



Keypad Lockout Feature (Loc): This feature is useful for prohibiting changes in the temperature set point or accidentally turning the unit off. Press and hold the “SET” key to display the current “Loc” setting. If “No”  is displayed, Lock

out is OFF and all keys are enabled. If “Yes”  is displayed, Lockout is ON and the “ON/OFF”, “WARMER”, and “COLDER” keys are disabled. However, the key tones remain enabled. While holding the “SET” key, press the “WARMER” or “COLDER” key to select the desired state. Release the “SET” key to confirm the selection.

NOTE

NOTE: The Information/Lockout Key “SET” remains enabled regardless of the “Loc” setting.





www.agamarvel.com

AGA MARVEL

P.O. Box 400
1260 E. VanDeinse St.
Greenville MI 48838

800.223.3900

41011912-EN Rev A
1/30/10

All specifications and product designs subject to change without notice. Such revisions do not entitle the buyer to corresponding changes, improvements, additions, replacements or compensation for previously purchased products.