

AGA Hotcupboard with Induction Top



Model # AHCIN



The AGA Hotcupboard with Induction Top gives owners a versatile cooking experience using advanced technology. Designed for those who love the many benefits of induction cooking and who require additional ovens for warming and simmering foods. This integrated solution attaches to the left of any 3-oven AGA Total Control or AGA Dual Control.

- Iconic AGA signature look with cast iron doors, front and top.
- Large 12”H x 12”W ceramic induction burner surface with a 9”H x 9”W defined pan area.
- Touch controls housed in the ceramic surface giving 10 Display Indicators and 9 Power Level settings including Power Boost, Residual Heat Indicator, a Timer and an Overheating Detector.
- Child Lock function to keep little hands safe and a Pause Setting to briefly interrupt the cooking session.
- Induction cooktop operates separate from the hotcupboard, is energy efficient, safe to operate and easy to clean.
- Simmering oven at the top of the hotcupboard is perfect for slow cooking meats giving you an additional slow cook oven when combined with any 3-oven AGA cast iron range.
- Warming oven at the bottom is perfect for keeping dessert warm while eating your meal and also for warming plates prior to serving.
- Seamless integration giving the look of one large range
- Includes one large handle to complete the integrated look

ORDERING DETAILS	MODEL #
Black	AHCIN-BLK
Claret	AHCIN-CLT
Cream	AHCIN-CRM
White	AHCIN-WHT
Pewter	AHCIN-PWT
British Racing Green	AHCIN-BRG
Dark Blue	AHCIN-DBL
Pearl Ashes	AHCIN-PAS
Aubergine	AHCIN-AUB
Duck Egg Blue	AHCIN-DEB
Heather	AHCIN-HEA
Pistachio	AHCIN-PIS
Aqua	AHCIN-AQU
Rose	AHCIN-ROS
Lemon	AHCIN-LEM

Must integrate with an AGA Total Control or Dual Control

Cast iron range is coated in hygienic, easy-to-clean vitreous enamel and is available in 15 colors



AGA Hotcupboard with Induction Top

Model # AHCIN



Technical Specifications	
Overall Dimensions	36"H x 19 1/8"W x 27 1/2"D
Cooktop Surface with Controls	16 1/2"H x 14 1/2"W
1. Ceramic Induction Burner	12"H x 12"W
Induction Defined Pan Area	9"H x 9"W
2. Simmering Oven	10"H x 13 3/4"W x 20 1/4"D
3. Slow Cook Oven	10"H x 13 3/4"W x 20 1/4"D
Weight	292 lbs
Shipping Weight	332 lbs
Electrical Requirements	240v, 40amp, 60Hz
Fuel/Power	Electric
Warranty	1 Year Limited Warranty on all parts and labor
Shipping Instruction	Ships fully assembled in separate carton

Induction Features

The large induction cooking surface features the following touch pad controls on its ceramic surface:

- Power Boost
- Residual Heat Indicator
- 9 Power Settings giving instant response
- A Timer and Pause Feature
- Overheating Detection
- Child Safety Lock



9" x 9" Defined Pan Area

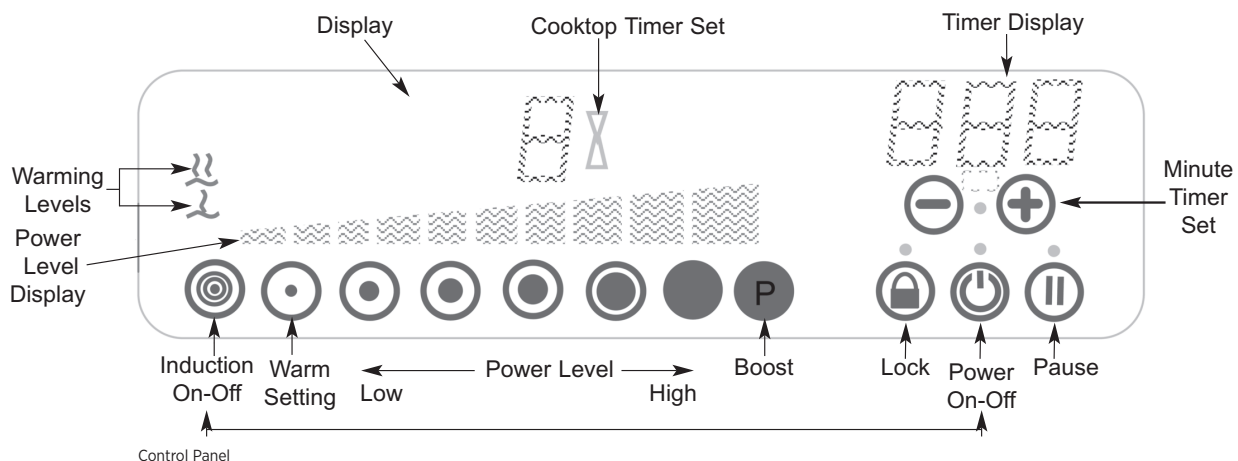

AGA Kitchen Concierge
1.800.525.5601

AGA Hotcupboard with Induction Top



Model # AHCIN

AGA TC5/DC5 - RANGE DIMENSIONS

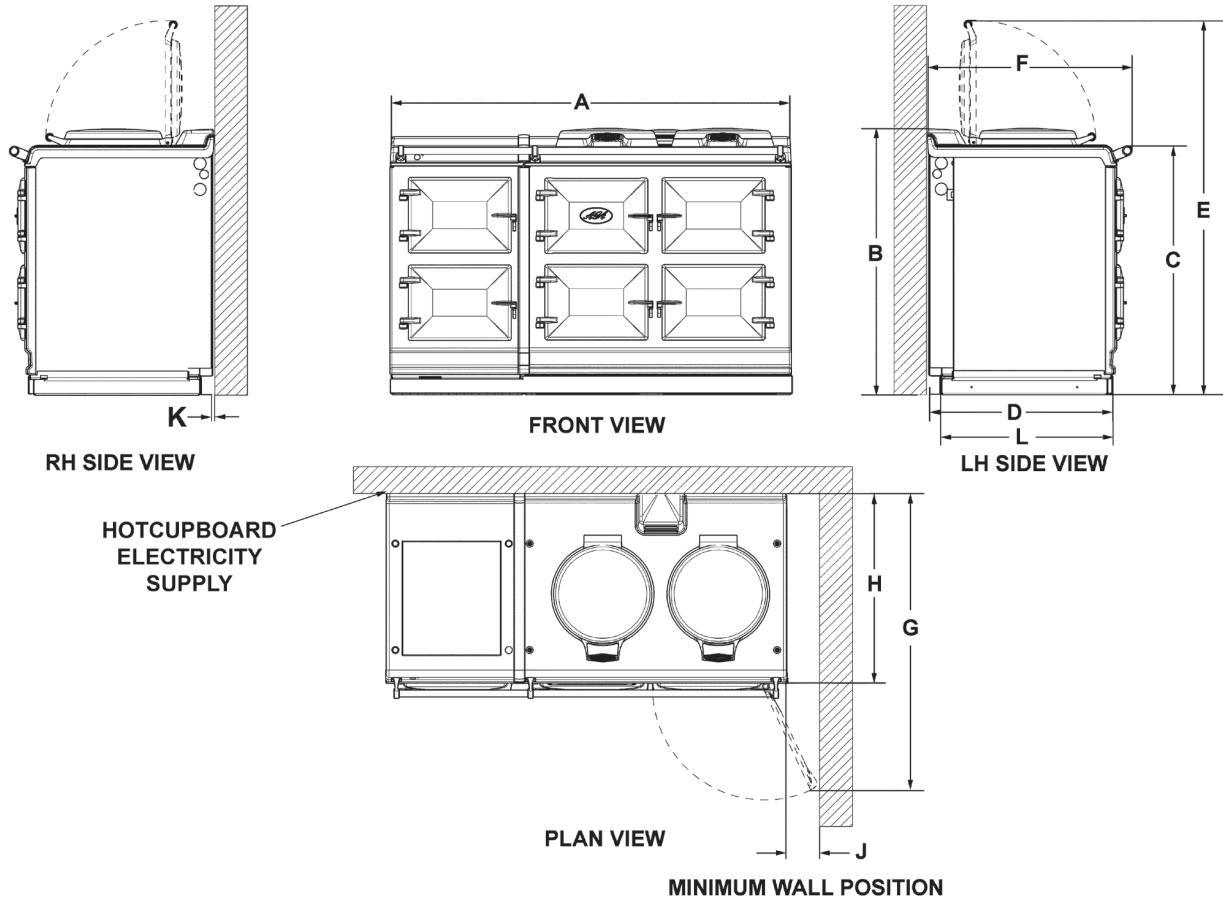

	A	B	C	D	E	F	G	H	J	K	L
mm	1478	951	913	680	1388	760	1145	698	116	10	634
ins	58 1/4	37 1/2	36	26 3/4	54 5/8	29 7/8	45 1/8	27 1/2	4 9/16	3/8	25

Fig. 11

AGA Kitchen Concierge
1.800.525.5601