



AGA

# Total Control Range Cooker



**AjMadison**  
Your Appliance Authority™  
800-570-3355

Redefining a British icon



introduction

# Welcome to AGA Total Control

And welcome to a better way to cook. The AGA Total Control range cooker is a newly designed version of the classic icon of British cooking. Three radiant-heat cast-iron ovens and two hotplates give you 10 delicious ways to cook in one range. Just imagine the ability to bake, roast, boil, simmer, and warm...all at the same time! The ovens are controlled and programmed with a state-of-the-art touch screen panel and remote handset, for flexibility you won't find on any other appliance.

Best of all, cooking on it is simple and the results are amazing. Read on to learn why the AGA Total Control range cooker will change the way you cook forever.

800-570-3355



Why it's time for  
AGA TOTAL CONTROL

great food  
total flexibility  
ambient warmth  
iconic design



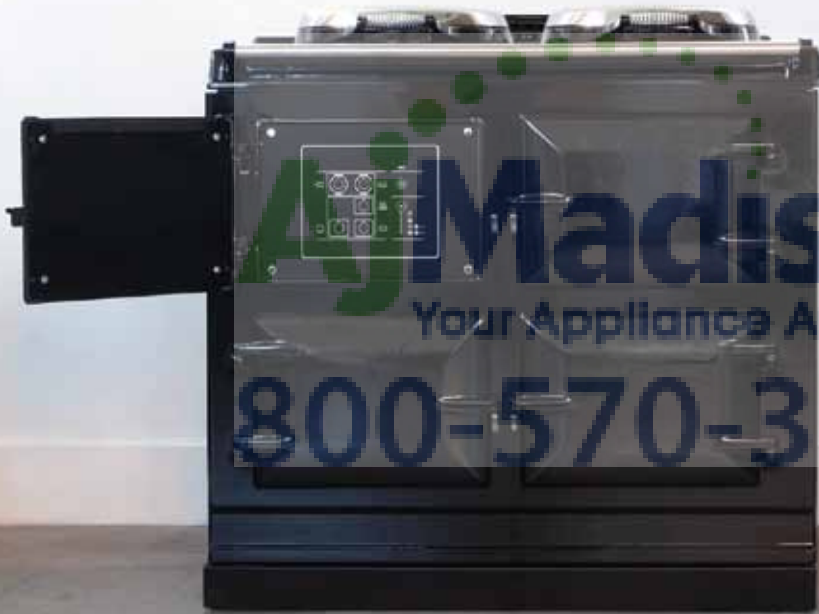

**Madison**  
Your Appliance Authority™  
800-570-3355





**AjMadison**  
Your Appliance Authority™

800-570-3355



living with AGA Total Control

## Why AGA cooked food tastes better

Ask any owner of an AGA heat-storage range cooker and they'll tell you that their food really does taste better. Cooking on an AGA feels intuitive and there's nothing this amazing cooker cannot do to perfection.

The cast-iron ovens of an AGA range cooker are gentle on food and lock in moisture, flavor, texture and goodness, meaning the food you serve tastes delicious.

The indirect radiant-heat within the ovens comes from all surfaces simultaneously, without the fierce, drying direct heat that is present in the elements or flames of other types of ranges.

Put simply, the AGA range cooker treats food as it should be treated – meaning you get the very best out of your ingredients.

It's not just statement food that the AGA is renowned for. It's just as kind to a 10-minute supper on a busy weekday evening. You'll never taste a better pizza, for example, and it cooks pasta, rice and stir-fries to perfection, incredibly quickly.

## More reasons why your AGA will make food taste incredible

The AGA is hailed as a design icon, but there's so much more to it than good looks. The AGA treats food differently and is perfect for every style of cooking.

- Radiant-heat – Typical gas and electric ovens rely on convection, creating “hot spots”. AGA ovens use radiant-heat to cook gently and evenly from all sides.
- Multi-functional – The ingenious oven design allows you to grill at the top of the roasting oven, bake in the middle, and fry on the floor – all while simmering, boiling, or toasting on the hotplates!
- Venting protects flavor – You can cook different types of food, such as fish and pastry, in the same oven and the flavors will not merge.



## Kind-to-food heat

Slow cook ovens lock in moisture and goodness, ensuring food tastes delicious and retains nutrients. In fact, root vegetables steamed in the slow cook oven can retain up to 20% more of their valuable mineral and vitamin content than those boiled in a saucepan.

The AGA Total Control does not require temperature dials as each oven and hotplate is pre-set to be at the right heat for the job, making cooking easy. Each oven is named by its function, rather like a chef's kitchen, with their patisserie and roast ovens.

Constructed of cast-iron with its incredible heat retaining qualities the roasting oven for instance is probably the nearest you get to a baker's brick oven or a wood-fired pizza oven in

the domestic kitchen. The ovens are large and can easily take a 28lb turkey and virtually all oven space can be used so cooking for a crowd becomes stress-free.



# The 10 Cooking Methods

## Hot Plates



### Boil

Water boils rapidly on an AGA. The boiling plate cooks so quickly that fresh vegetables retain more of their natural flavor, color, and nutrients. It provides a good rolling boil for making quick jam.



### Simmer

The simmering plate's gentle heat is perfect for making sauces and simmering soup.



### Grill

Succulent steaks and chops are cooked on your AGA boiling plate in the special cast-iron grill pan. Fierce heat reminiscent of a charcoal grill sears the outside of the meat, sealing in flavor and juices while the meat gently cooks to perfection in the inside.



### Stir Fry

Tackle Asian cooking with an AGA wok on the boiling plate for fast stir fries and quick cooking.



### Fry

Create crunchier-on-the-outside, moister on the inside fried/sautéed chicken.



### Toast

Using the special wire toaster, you can make the famous AGA toast crunchy on the outside and fluffy in the middle. AGA toast tastes better and even looks better; every slice is branded with the distinctive waffle pattern. Toasted sandwiches can be cooked directly on the simmering plate.

## Ovens



### Roast

Roasts are superb – cooked evenly throughout because, unlike conventional ranges, the heat comes from all directions, not just one. Shrinkage and dryness are reduced because there are no flames or elements inside the ovens to dry out the meat. Roasted vegetables are full of Mediterranean flavor and roast potatoes are golden brown.



### Bake

Like a traditional baker's brick oven, the AGA roasting and baking ovens provide all-around, consistent heat, to create feathery pastries, moist cakes, and perfectly baked breads. Sweet and savoury can be cooked together without intermingling flavors.



### Steam

In the AGA slow cook oven or on slumber mode, the AGA Total Control can steam a sponge pudding to perfection without turning your kitchen into a sauna, and unpleasant lingering cooking smells are banished. Steaming root vegetables locks in their full flavor and nutrients.



### Slow Cook

The slow cook oven's gentle persistent heat helps you create richer, juicier casseroles, stews, and slow roasting or braising cuts of meat. It slow cooks for hours.

time for AGA Total Control

## It's the AGA Range Cooker for all times

AGA Total Control enables you to use a 'different' AGA every day. You can choose to use it like a classic AGA heat-storage cooker with all ovens and hotplates on – or simply use a single hotplate or oven.

With our increasingly busy lifestyles – and the natural changes in routine over time – AGA Total Control fits in seamlessly with how you live your life, offering ultimate flexibility and convenience.

Thanks to the easy-to-use touch-screen panel, there is a setting for every family's need or occasion – available on demand at the touch of a button.

The ovens can be programmed to be ready to make breakfast when you come down in the morning and be set to go off as you close the front door. They can be programmed to be ready if there are children coming in from school or for when you come in from work. They can be ready for supper and stay on until it's time to turn in.

AGA Total Control is the AGA range cooker for all times, providing all the benefits of 'kind-to-food' cast-iron cooking combined with technology that has created an AGA perfectly in tune with your family's way of living...



All Madison  
Your Appliance Authority™  
800-570-3355

AGA

NEWGATE

CLOCKS

# Control at the touch of a button

At the heart of the electric AGA Total Control is a touch-screen control panel which puts you in charge of how and when the range cooker is used. Discreetly housed behind the top left door, the nerve center of the AGA Total Control can be accessed directly or programmed via a remote control handset.

Using the control panel, the hotplates and ovens can be turned on manually when needed. It's so flexible – you can heat only one hotplate or both. You can opt to heat only the roasting oven, the baking oven or the slow cook oven – or all three.

...but the touch-screen panel does so much more

Alternatively using the remote control handset, you can even program the cast-iron ovens to come on automatically for one or two cooking cycles per day, seven days a week.

You can also set the AGA Total Control to provide the constant ambient warmth to the kitchen for which the AGA cooker is renowned.



# Automatically ready

## Manual (you choose)

Each zone (an oven or a hotplate) can be operated individually in manual mode. Any zone selected will remain on until switched off.

## Slumber (ovens only)

In this mode all three ovens are active, pre-set at a simmering heat. Slumber setting is ideal for slow cooking and giving a gentle heat into the kitchen, creating that unmistakable ambient AGA warmth. When the ovens are in slumber mode, they take less time to reach full heat.

## Auto (ovens only)

Selecting the auto function brings selected ovens up to full heat from OFF when a program is set. The ovens can be selected to operate once or twice each day, with the start and finish time of the 'cooking cycles' set by the user.

## Auto slumber (ovens only)

Choosing this setting automatically brings the ovens up to full heat from slumber mode.

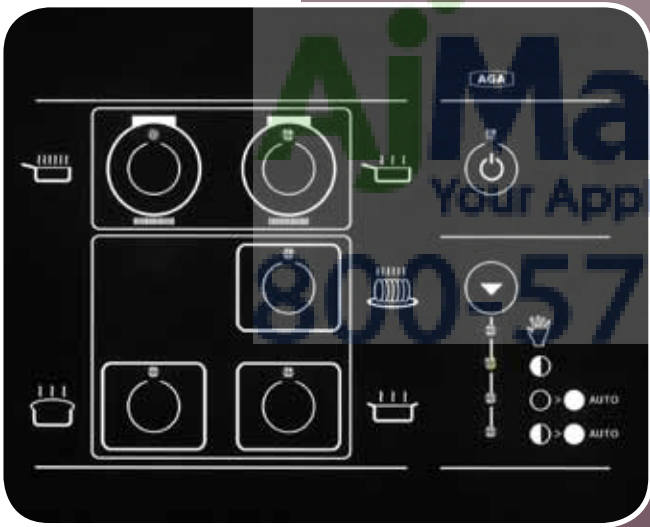

# The hotplates

Both of the hotplates on the AGA Total Control – the boiling plate and simmering plate – can be turned on or off independently as required simply by pressing the appropriate button on the control panel. Both hotplates are operated manually.

The patented engineering technology behind the AGA Total Control means each hotplate is independently heated by its own element. This means constant heat when the hotplate is on. This also means that using the hotplates does not affect the heat in the ovens, as each zone is independently heated.

Both hotplates are a generous 14 1/2" wide, compared to normal 6" or 8" cooktop element. You have plenty of room for large pans or multiple saucepans.

At Madison  
Your Appliances Authority  
800-570-3355

## how it works

The boiling plate is on the left-hand side. It is the hotter of the two hotplates with a maximum temperature of 626°F. Water reaches a full boil very rapidly.

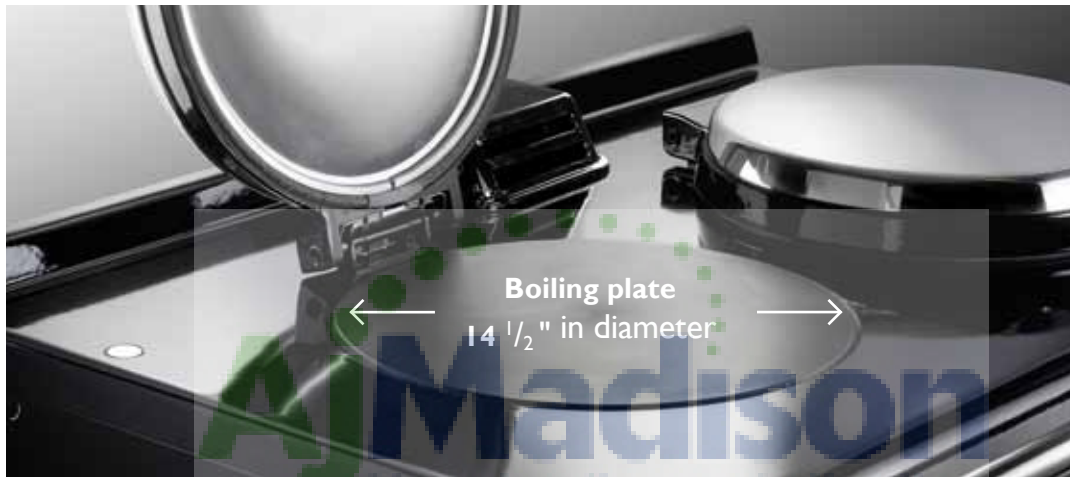

The simmering plate is on the right-hand side. It is the cooler of the two hotplates with a maximum temperature of 392°F.



# The ovens

The AGA Total Control range cooker represents an important breakthrough in heat-storage engineering. Patented technology developed within our own research and development facility means that, for the first time, each oven has its own heat source. The result is increased programmability, more even heat distribution and more consistent oven temperatures.

What hasn't changed is that this next generation AGA still works on the principle of radiant kind-to-food heat, meaning that – just like classic AGA heat-storage cookers – it cooks beautifully, locking in flavor and moisture.

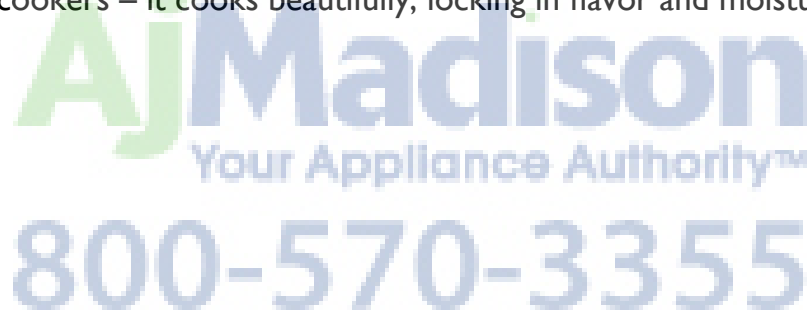

Each oven has its own heat source,  
meaning consistent oven temperatures

## how it works



### Slow cook oven

The AGA Total Control slow cook oven allows flavors to develop and making even the toughest meats tender. Its large capacity allows several pans to be stacked and a number of dishes to be cooked simultaneously.



### Baking oven

A moderate oven for baking cakes and biscuits, cooking fish, lasagne or a shepherd's pie, the AGA Total Control baking oven is truly flexible. And cooking sweet and savoury dishes together is no problem as the flavors do not mix.



### Roasting oven

The roasting oven on the AGA Total Control grills, roasts and bakes bread beautifully. But new technology means it is possible to use only the roasting oven or to use it alongside either or both of the other two ovens.

AGAMARVEL.COM  
Your Appliance Authority  
800-570-3355



**AjMadison**  
Your Appliance Authority™

800-570-3355



It's a

*adore*

**AjMadison** DESIGN

Your Appliance Authority

800-570-3355

icon



The Total Control combines timeless design with modern control technology to become the centerpiece of any kitchen. With a look like no other range, it's instantly recognized by anyone serious about European cooking.

Famous AGA owners include:

**HRH Prince Charles**

**David Cameron**, British Prime Minister

**Madonna**, singer/songwriter

**Shania Twain**, singer/songwriter

**Colin Firth**, actor

**Sting**, singer/songwriter

**Claudia Schiffer**, model

**Jamie Oliver**, TV chef

**HRH Princess Royal, Anne**

**Elle Macpherson**, model

**Sharon Stone**, actress

**Julie Walters**, actress

**Jade Jagger**, designer

**Elizabeth Hurley**, actress

**Paul McCartney**, singer/  
songwriter

**Kate Winslet**, actress

# living with AGA Total Control

Dream in color



Black



Pearl Ashes



Pewter



Cream



Blue



British Racing Green



Aubergine



White



Heather



Duck Egg Blue



Pistachio

Standard colors

Signature colors

AGAMadison  
Your Appliance Authority™  
800-570-1355

Please note that while we take every care to ensure these colors are accurate, they are only as close as the printing process will allow. The unique enamelling process means that colors may darken when in use. Color samples are available in AGA shops.



**AGA**  
THE WORLD'S  
MOST FAMOUS COOKER  
AND WATER HEATER

At your service  
day and night

Saves time, work  
and trouble

A 30-year  
investment

And it's yours for  
£2 a month

DO ALL YOUR  
COOKING

PROVIDES TURNS  
HOT WATER DAILY

FOR THE LOW PRICE  
OF ONLY £2 A MONTH

OUR OWN  
WARRANTY

YOUR AGA WILL

**AGA Madison**

How to join the **AGAstocracy**

...and make life a bed of roses

DO ALL YOUR COOKING

PROVIDES TURNS HOT WATER DAILY

FOR THE LOW PRICE OF ONLY £2 A MONTH





# The AGA Heritage



THE ELECTRIC BLUE AGA



The AGA is Britain's best loved range cooker.

The story began in 1922 when it was invented by Nobel prize-winner Dr Gustaf Dalen, world renowned Swedish physicist. Confined to his home after a failed experiment cost him his sight, Dalen was inspired to create a better, simpler, more efficient cooker for his wife, Elma, who constantly had to tend to their old fashioned stove.

He was determined to develop a cooker capable of every culinary technique which was easy to use and guaranteed perfect results. And he did. The now famous AGA was born.

In 1932 manufacturing also began in Britain. Today's AGA is now solely made at the famous historic Coalbrookdale Foundry in Shropshire, England. Coalbrookdale is famous for being the birthplace of the Industrial Revolution and is a UNESCO World Heritage Site.

Today the AGA is more than a cooker; it's a way of life. Owners tell us their AGA adds heart and soul to their home. It's impossible to think of any other household appliance that inspires such a level of loyalty and devotion and has such emotional resonance with owners.

The AGA's classic design is timeless. The polished stainless steel insulated covers with spiral handles are a distinctive AGA hallmark, as is the iconic AGA badge.

Customers often tell us they designed and built their kitchen around it.

Go into any AGA owner's home and you'll find them in the Kitchen.



BREAD

800-570-3355

Madison  
Your Appliances Authority

# AGA Total Control Dimensions\*



Height  
35 7/8"

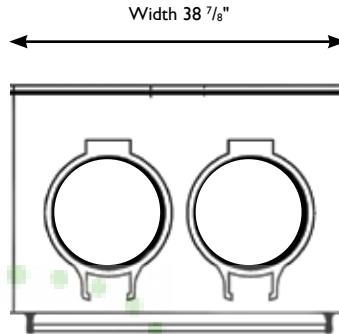

Width 38 7/8"

Depth  
27 1/2"

3 oven 30-amp electric AGA Total Control  
approximate weight 880 lbs

Oven doors are shipped unattached. Once doors are installed via simple hinge-pin system (no tools required), the unit is ready to plug in for use. 6ft., 4 prong power cord attached.

C. Control panel

1. Boiling plate

2. Simmering plate

3. Roasting oven

4. Baking oven

5. Slow cook oven

Height

Width

Depth (Shelf)

Oven dimensions

9 3/8"

13 3/8"

18 3/4"

\*For exact dimensions, please refer to installation instructions

# It's time for Total Control

## It's time for an AGA

### United States

AGA MARVEL  
1260 E Van Deirse St  
Greenville, MI 48838  
800-223-3900

### Canada

AGA MARVEL  
SOFA Galleries  
6900 Airport Road  
Suite 205  
Mississauga ON, L4V1E8  
855-213-2785

To get the very best from your AGA, reserve your space at an AGA cooking demonstration - Call 800-223-3900 in the US or 855-213-2785 in Canada

**800-579-3355**



## Total Control

Copyright © AGA Rangemaster Limited 2011. Brand names, words and logos are registered trademarks of AGA Rangemaster Group, Juno Drive, Leamington Spa, Warwickshire, CV31 3RG.

AGA is a trading name of AGA Rangemaster Limited. Registered in England & Wales under registered number 3872754. Registered office: Juno Drive, Leamington Spa, Warwickshire CV31 3RG England. Patent pending number 1008608.

Part of the  
**AGA RANGEMaster**  
Group

This information contained in this brochure is provided as a guide only, and should not be relied upon. For full technical and installation details, refer to the relevant Users and Installation Guide. Installation is subject to site survey. We reserve the right to change specifications without notice at any time.