

A1PU6



Free-Standing Dual Fuel "Opera" Range,
36" , Cream

Exclusive professional style
AISI 304 Stainless Steel
Ergonomic control knobs

OVEN
Multifunction oven with 9 cooking modes
Digital analogue LED electronic clock/
program feature
Stay clean liners
Air cooled door
Triple glazed removable door
Halogen oven lights
Storage drawer beneath the oven

Oven capacity: 3.2 Cu. Ft.
Usable oven capacity: 2.47 Cu. Ft.
Bake element: 1900W at 240V - 1600W
at 208V
Broil element: 1750W at 240V - 1450W
at 208V
Convection element: 2750W at 240V -
2250W at 208V

GAS RANGETOP
Heavy duty cast iron grates
Full width grates
Sealed burners
Automatic electronic ignition
Safety valves
LP Gas conversion kit included

5 Gas burners:
Front right: 5,200 BTU burner
Back right: 10,000 BTU rapid burner
Central: 3,000 (inner) - 12,000 (outer) BTU
double inset super burner
Back left: 10,000 BTU rapid burner
Front left: 10,000 BTU burner
4" Stainless steel backsplash as standard

Voltage rating: 240/208V - 60Hz
Connected load (nominal power): 240/208V-
4.3/3.7kW

Amps @ 240/208V: 15.5 / 13

Gas inlet location: Back right top

ACCESSORIES INCLUDED:

2 baking trays
1 wire rack
1 rotisserie kit
1 wok ring

FUNCTIONS



OPTIONS

- KIT1A1-6 - 29 ½" Stainless steel backsplash



- KIT2A1P-2 - Kick plate
- KIT3P6 - Height extension (to rise appliance 2")
- KIT4A1P - Deep kick plate (for use with KIT3P6)
- KD90XU - Wall mounted hood, stainless steel, 90 cm (approx. 36 inch)
- GTA-6 - 3 Level telescopic shelf set
- WOKGHU - Cast iron wok ring
- TPKX - Tepenjaki grill plate

VERSIONS

- A1XU6 - Stainless steel
- A1AU6 - Anthracite
- A1RWU6 - Glossy red wine
- A1NU6 - Glossy black

A1PU6



Free-Standing Dual Fuel "Opera" Range, 36", Cream



		<p>Top and bottom heat: This method is known as "conventional" cooking, and is suitable for dishes that require a more gentle heat, such as baking. The oven needs to be pre-heated to the required temperature, and is best suited for single items, such as large cakes. Best results are obtained by placing food in the centre of the oven.</p>
		<p>Convection with top and bottom heat: The elements combined with the fan aim to provide more uniform heat. This is a similar method to conventional cooking, so pre-heat is required. This is not as effective as european convection cooking but can be used to cook biscuits and pastry.</p>
		<p>Intensive broil: This allows rapid cooking and browning of foods. Best results can be obtained from using the top rack for small items, the lower racks for larger items, such as chops or sausages. Cooking using this method should be carried out with the door closed, unless instructed to do otherwise.</p>
		<p>Convection broil: Please note: cooking in this mode is conducted with the door closed. The fan reduces the fierce heat from the broiler, providing an excellent method for broiling a range of foods; chops, steaks, sausages etc. without having to turn the food during cooking. This gives good results, reduces drying out of foods, and gives even browning and heat distribution, the top two racks being recommended for use. The lower area of the cavity can also be used to keep other items warm at the same time.</p>
		<p>Convection with bottom heat: This combination quickly completes the cooking of foods that are ready on the surface, but require more cooking inside, without further browning. Suitable for any type of food.</p>
		<p>European convection with bottom heat: The addition of the lower element adds extra heat at the base for food which requires extra cooking.</p>
		<p>European convection: The combination of the fan and circular element around it, gives uniform heat distribution with no cold spots. This has benefits - no preheat if cook time is more than 20 minutes, no flavour transfer when cooking different foods the same time, less energy is needed, and it cooks at 10% quicker than a normal oven.</p>
		<p>Defrost: The circulation of air at room temperature enables quicker thawing of frozen food, (without the use of any heat). Ideal for use prior to cooking of readymade dishes, or cream filled products etc.</p>
		<p>Rotisserie: The rotisserie (where installed) works in combination with the grill element to brown foods to perfection.</p>

A1PU6



Free-Standing Dual Fuel "Opera" Range,
36", Cream

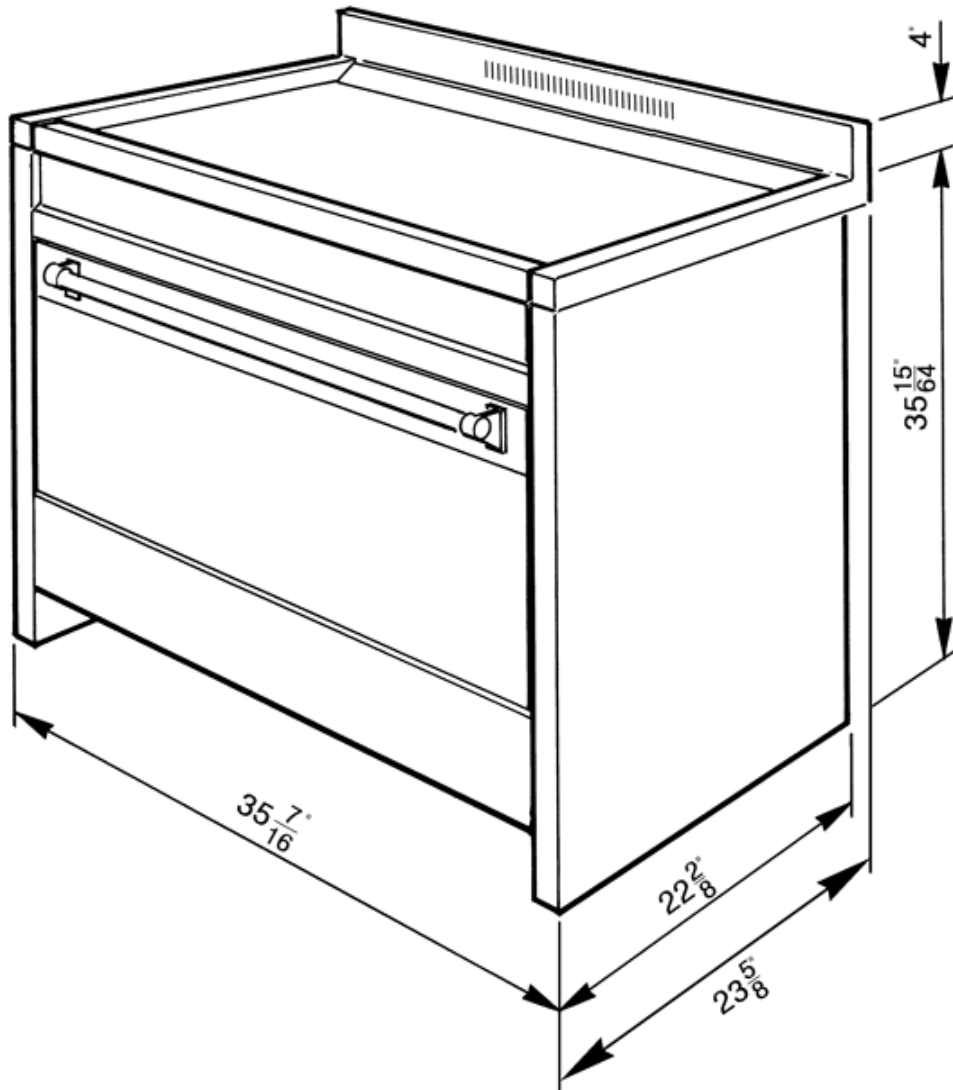

SMEG USA INC.
A&D BUILDING
150 EAST 58th STREET
7th FLOOR
NEW YORK, NY, 10155