

# MAS486INMXV

MASTER SERIES INDUCTION RANGE 48" - 6 HEATING ZONES - ELECTRIC  
OVEN - STAINLESS STEEL FINISH



## Fingerprint resistant stainless steel finish

Make cleaning a breeze thanks to the fingerprint resistant finish on all knobs, handles and oven door surfaces.

## Bertazzoni signature counter-deep maintop

Bertazzoni signature stainless counter-deep maintop is designed to install flush with most kitchen countertops for a perfectly integrated look. Precise and flexible heating is provided by 6 latest generation extra-large induction zones with bridging of right-side zones. Complete the range with the optional cast-iron griddle.

## Extra large oven with dual convection

The 4.7 cu.ft electric main oven with dual horizontal convection allows even baking and roasting on 7 shelf levels. A 2.4 cu.ft auxiliary electric oven with broiler helps prepare multiple dishes at the same time. Bertazzoni ovens are equipped with an extra-large high-power broiler for broiling and grilling.

## Advanced programming and controls for the oven

The elegant temperature gauge for control of oven temperature during pre-heating and baking is a signature of every Bertazzoni range.

## Best-in-class features and design

The soft-motion oven door with edge-to-edge tempered glass is a masterpiece of European engineering and makes the oven door very easy to wipe clean. The range is equipped with an elegant stainless steel toe kick matching the finish of the range.

## GENERAL CHARACTERISTICS

Worktop	6 induction zones
Front right	2100W (3700W booster)
Front left	2300W (3700W booster)
Center	2300W (3700W booster)
Back right	2100W (3700W booster)
Back left	2300W (3700W booster)
Back center	2600W (3700W booster)
Knobs	Metal
Cooking modes	9
Tray	1 baking tray with grill trivet
Shelves	1 telescopic + 1 standard
Levels	Lateral grids
Inner door	3 layer tempered glass
Door hinges	Soft motion
Auxiliary oven cooking modes	5
Auxiliary oven shelves	1 telescopic + 1 standard
Auxiliary oven levels	Lateral grids
Legs	Stainless Steel ø 2 3/8 inches
Toe kick	Integrated stainless steel toe kick included

## TECHNICAL SPECIFICATIONS

Electrical requirements	120/208 V 60HZ - 13700W 120/240 V 60HZ - 16800W 50A with dedicated circuit
Warranty	2 years parts & labor
Packaging dimensions	H:42 1/8 W:51 15/16 D:29 15/16

## ACCESSORIES SECTION

DSMASIKSG	Satin gold décor set - 11 knobs
DSMASIKSB	Black nickel décor set - 11 knobs
DSMASHSG	Satin gold décor set - 2 handle terminals
DSMASHSB	Black nickel décor set - 2 handle terminals
GR11ISI	Cast iron griddle for induction

# MAS486INMXV

MASTER SERIES INDUCTION RANGE 48" - 6 HEATING ZONES - ELECTRIC OVEN - STAINLESS STEEL FINISH



## DIMENSIONS

SIDE VIEW

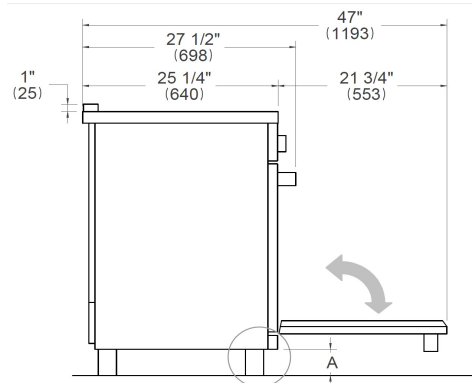

FRONT VIEW

LEG DETAILS

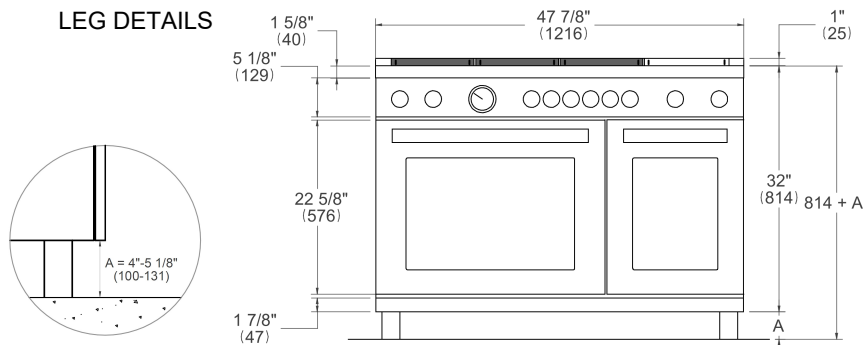

WORKTOP DETAILS

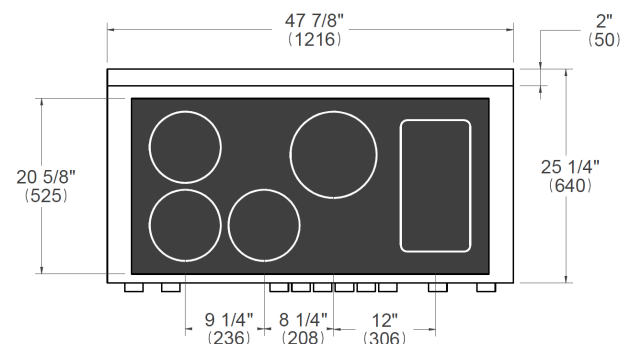

REAR VIEW

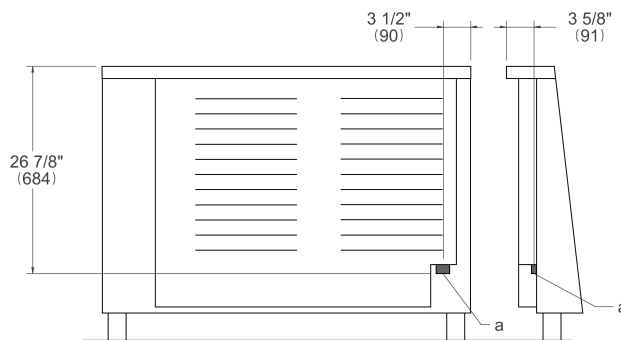

## INSTALLATION

**E** A properly-grounded horizontally mounted electrical receptacle should be installed no higher than 3" (7.6 cm) above the floor, no less than 2" (5 cm) and no more than 8" (20,3 cm) from the left side (facing product). Check all local code requirements.

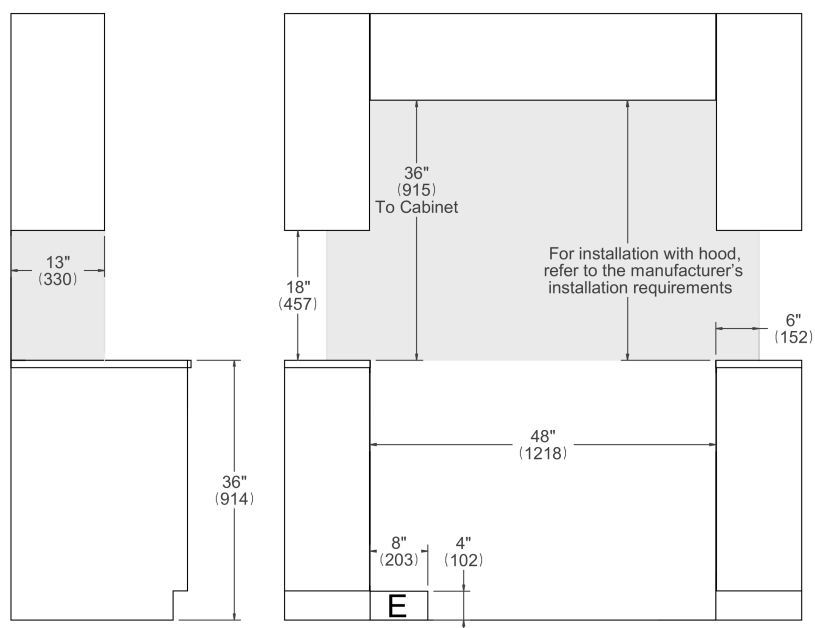

### NOTE

- a. Electrical Connection
- b. Gas Connection

Disclaimer: while every effort has been made to insure the accuracy of the information contained in this document, Fratelli Bertazzoni reserves the right to change any part of the information at any time without notice. For detailed installation specifications consult the installation manual. Fratelli Bertazzoni, Bertazzoni and the winged wheel brand icon are registered trademarks of Bertazzoni Spa.