

SWC1735C

72.0" x 23.63" x 23.5" (H x W x D)

Commercially approved full-sized wine cellar with European preservation system and curved glass door

Highlights:

Commercially approved for use in foodservice establishments

Curved glass door with double tempered design and elegant tint

Reduced maintenance with automatic defrost

Wooden shelves offer stable bottle storage with a classic look



Commercially approved	UL-S listed to ANSI-NSF standards for use in foodservice establishments
Large capacity	Interior can hold up to 120 bottles
Automatic defrost	Reduced maintenance with the convenience of auto defrost
Curved double pane tempered glass door	Heat resistant design and tinted look provides elegant display of stored collection
Wooden shelves	Slide-out wooden shelves for proper bottle storage
Adjustable thermostat	Manage the temperature with ease and accuracy
Interior light	Automatically illuminates when you open the door
Full aluminum handle	Comfortable design with a professional appearance
Activated carbon filter	Provides odor control
Reversible door	Keep your options flexible with a reversible door that is easy to switch when your arrangement changes

Specifications:

Height	72.0"
Width	23.63"
Depth	23.5"
Shipping Weight	222.0 lbs.
Weight	200.0 lbs.
Amps	2.0
Canadian Electrical Safety	ULC
US Electrical Safety	UL
Voltage/Frequency	115 V AC/60 Hz
Reversible	Yes
Door Swing	RHD
Shelf Quantity	5
Adjustable Shelf	true
Shelf Type	Wood
Wine Bottle Holder	true
Wheel Quantity	2
Defrost Type	Automatic
Light	true
Thermostat Type	Dial
Freon Type	R134a
Low Side PSI	87.0
Level Legs Quantity	4
High Side PSI	430.0
Freon Oz	3.9
Compressor Warranty	5 Years
Parts/Labor Warranty	1 Year
Sanitation	UL-S

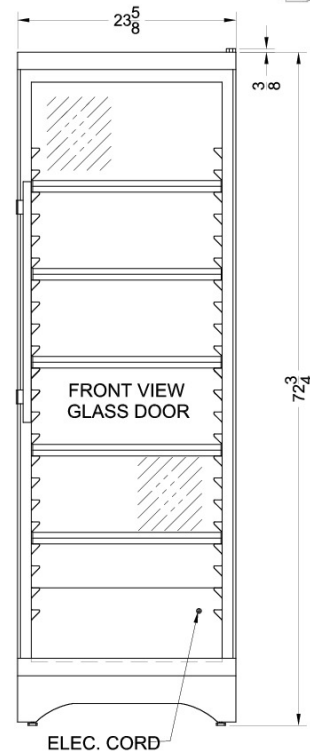
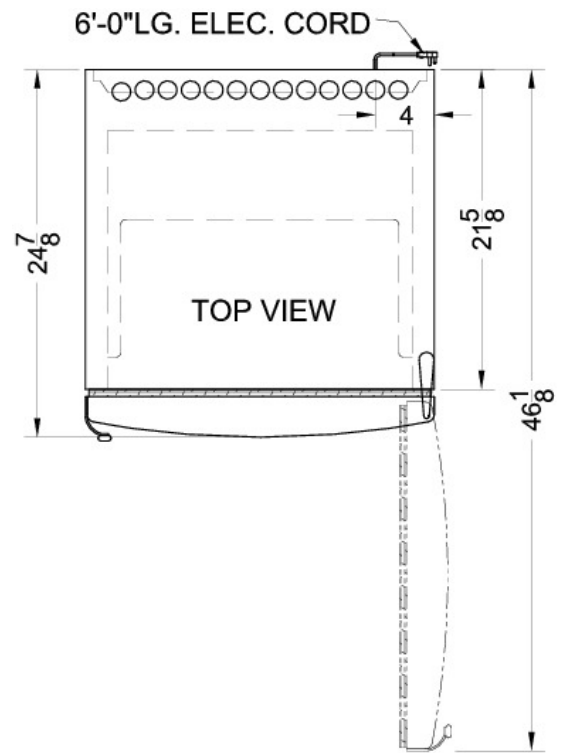

Summit Appliance Division, Felix Storch, Inc.
 770 Garrison Ave • Bronx, NY 10474
 Phone: 718-893-3900 • Fax: 718-842-3093
 Email: info@summitappliance.com