

## PRODUCT MODEL NUMBER

LTG6234D

**Gas supply:** Dryer is equipped for use with NATURAL gas. Dryer can be converted to L.P. gas. When rigid pipe is used it should be 1/2 inch IPS. When acceptable to the gas supplier and local codes, 3/8-inch approved tubing may be used for lengths under 20 feet. For lengths over 20 feet, larger tubing should be used. Pipe-joint compounds resistant to the action of L.P. gas must be used. This washer/dryer is equipped with its own permanent, flexible gas connector, design-certified by CSA International, for connecting the appliance to the gas supply line. An individual manual shutoff valve must be installed within 6 feet of the dryer in accordance with the National Fuel Gas Code ANSI Z223.1.

**Electrical:** A 120-volt, 60 Hz, AC-only, electrical supply is required. 15 or 20 amp fused circuit. A separate circuit serving only this appliance and a time-delay fuse or circuit breaker is recommended.

**Exhaust venting:** Exhaust your dryer to the outside. Four-inch diameter vent is required. Rigid or flexible metal exhaust vent must be used. Do Not use plastic or metal foil vent. Exhaust outlet hood must be at least 12 inches from the ground or any object that may be in the path of the exhaust. The dryer can be converted to exhaust out right or left side.

## EXHAUST VENTING

**Plan installation to use the fewest number of elbows and turns.**

**Maximum length** of the exhaust system depends upon the type of vent used, number of elbows and the type of exhaust hood. The maximum length for both rigid and flexible vent is shown in the chart.

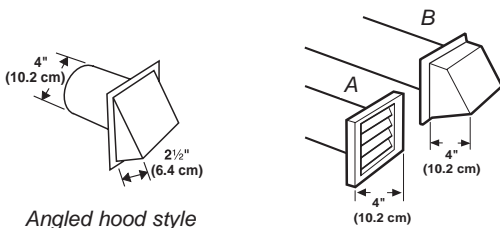

A. Louvered hood style  
B. Box hood style

### Vent Length Chart

No. of 90° turns or elbows	Type of Vent	Box or Louvered hoods	Angled hoods
0	Rigid metal	37 ft (11.3 m)	35 ft (10.7 m)
	Flexible metal	25 ft (7.6 m)	20 ft (6.1 m)
1	Rigid metal	32 ft (9.7 m)	27 ft (8.2 m)
	Flexible metal	21 ft (6.4 m)	16 ft (4.9 m)
2	Rigid metal	24 ft (7.3 m)	19 ft (5.8 m)
	Flexible metal	15 ft (4.6 m)	10 ft (3.0 m)

**NOTE:** Side exhaust adds a 90° turn inside the washer/dryer. To determine maximum exhaust length, add one 90° turn to the chart.

## OVERALL DIMENSIONS

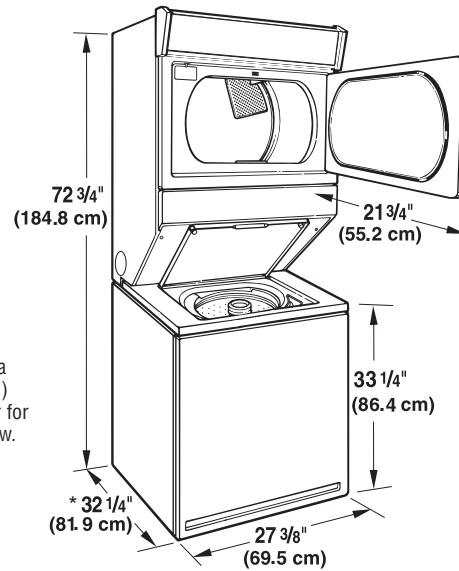

\* Most installations require a minimum 5-1/2 in. (14 cm) clearance behind the dryer for the exhaust vent with elbow.

## RECESSED AREA AND CLOSET INSTALLATION

Additional clearance for wall, door and floor molding may be required.

Rear clearance may be 0 in. when house exhaust system is lined up directly with dryer exhaust.

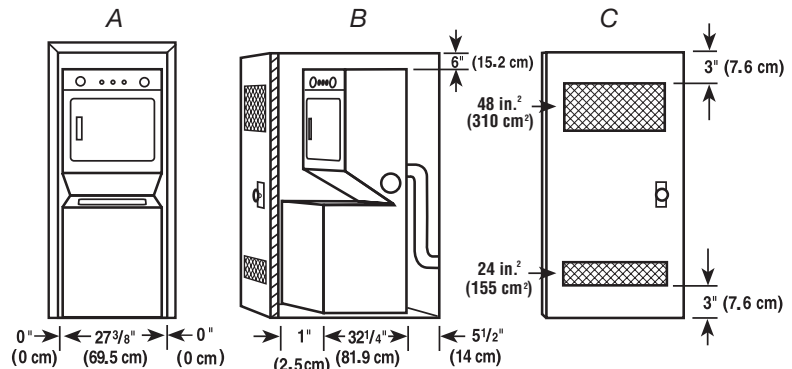

A. Recessed area  
B. Side view - closet or confined area  
C. Closet door with vents

## DRAIN SYSTEM

### Standpipe drain system - wall or floor

The standpipe drain requires a minimum diameter standpipe of 2" (5 cm). The minimum carry-away capacity can be no less than 17 gal. (64 L) per minute. A 2" (5 cm) diameter to 1" (2.5 cm) diameter standpipe adapter kit is available.

The top of the standpipe must be at least 39" (99 cm) high and no higher than 96" (2.4 m) from the bottom of the washer.

### Laundry tub drain system

The laundry tub needs a minimum 20 gal. (76 L) capacity. The top of the laundry tub must be at least 34" (86.4 cm) above the floor and no higher than 96" (2.4 m) from the bottom of the washer.

### Floor drain system

The floor drain system requires a siphon break that may be purchased separately.

The siphon break must be a minimum of 28" (71 cm) from the bottom of the washer. Additional hoses might be needed.