

811065

E-Series Wall Oven/Microwave Trim Kit - MWTRIM30-2/S

CONTAINS:

E-Series MW24

<u>QTY</u>	<u>DESCRIPTION</u>	<u>QTY</u>	<u>DESCRIPTION</u>
1	Frame Assembly	2	Small Glass Trim
1	Mtg Bracket, Rt	2	Large Glass Trim
1	Mtg Bracket, Lt	1	Bottom Ductwork MW24
6	Screw, 8-18x3/8" Type B H/W/HD	2	Large Foam
6	Screw, 6-18x1" TPG Type A	2	Small Foam
2	Screw, #8-15x1/2" Truss HD	1	Instructions
2	Framed SS Trim		

INSTALLATION PROCEDURE:

Cabinet Opening Preparations and Installation of Mounting Brackets

1. Locate properly grounded 3-prong receptacle within 4" (102mm) from the right side and 4" (102mm) up from bottom of microwave oven cabinet.

⚠ CAUTION

Install the MW24 with a 120V, 60Hz, on a dedicated circuit. This outlet must be checked by a qualified electrician to see if it is wired with correct polarity and is correctly grounded. A GFCI outlet is not recommended as this may cause product operation interruptions.

2. The floor of the opening should be constructed of plywood strong enough to support the weight of the oven and floor load (about 100lbs/.45kg). The floor should be level for proper operation of oven. Be sure to check local building code as it may require that the opening be enclosed with sides, ceiling and rear partition. The proper functioning of the oven does not require this enclosure.
3. Locate mounting brackets and attach them with six #6x1" screws, making sure brackets do not extend beyond front surface of the cabinet opening.

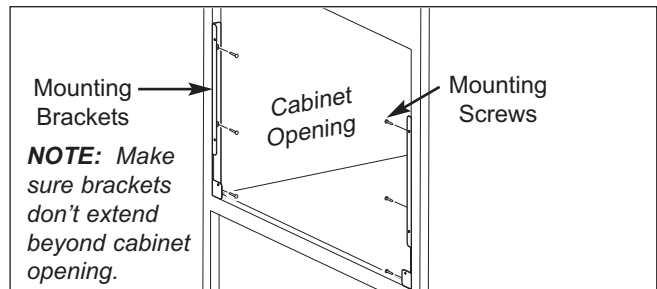

Figure 1. Cabinet Preparation

NOTES:

- Always pre-drill a pilot hole before installing screws to avoid damage to cabinet or trim kit hardware.
- The location of the mounting bracket will control the height of the trim kit relative to the surrounding cabinetry and microwave (See Figure 1).

811065

E-Series Wall Oven/Microwave Trim Kit - MWTRIM30-2/S

Bottom Duct, Microwave & Decorative Trim Install

1. Center the bottom duct assembly in the opening. Secure assembly to the base of cabinet opening, using #8-15x1/2" truss head screws (See Figure 2).
2. Plug power cord in. Carefully guide microwave into opening, lining up feet of microwave with holes in bottom duct assembly. **NOTE:** Verify that the power cord is not pinched between the microwave oven and the wall. Then lower microwave onto bottom duct assembly (See Figure 2).
3. Finally, attach the frame assembly directly to the cabinet opening, using four #6-18x1" wood screws. The inside edges of frame assembly should coincide with the edges of the cabinet opening. **NOTE:** Always pre-drill a pilot hole before installing screws to avoid damage to cabinet or trim kit hardware.
4. Adhere decorative trim panels to the side brackets, so they are tight to the side and bottom of the frame assembly (See Figures 3 & 4). **NOTE:** The two pieces of foam tape are to be used if gaps appear between the frame and the microwave perimeter. If gaps are present, remove the trim and adhere the foam tape to the microwave where needed.

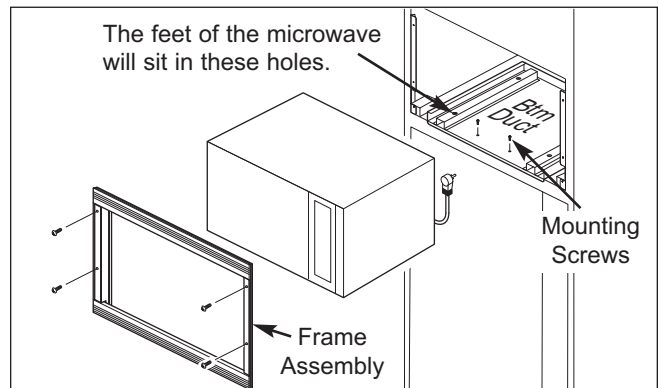

Figure 2. Microwave Install in Cabinet Opening

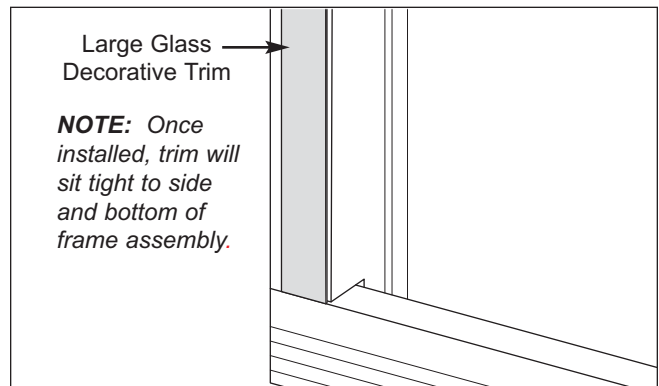

Figure 3. Decorative Trim / Unframed Assembly

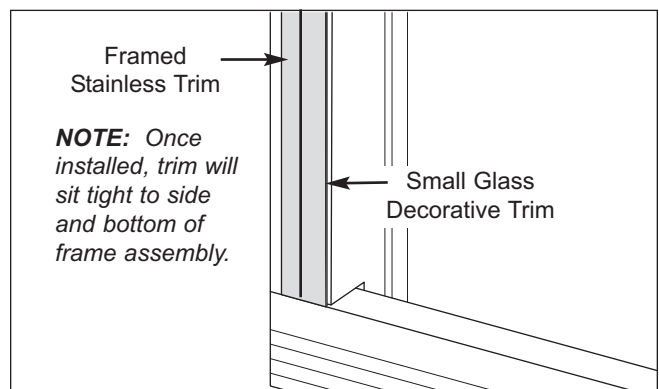

Figure 4. Decorative Trim / Framed Assembly