

# 802781, 802782, 802783, 812340, 812341, 812342, 814020, 815837, 820395 Warming Drawer Handle Installation Instructions

802781	Handle, Tubular 23-1/2" Classic	812342	Handle, Pro 25-7/8"
802782	Handle, Tubular 23-1/2" Carbon	814020	Tube Handle, 3/4" Unframed
802783	Handle, Tubular 23-1/2" Platinum	815837	Tube Handle, 3/4" Framed
812340	Handle Curved 26-7/8" Framed	820395	Tube Handle, 3/4" Black
812341	Handle, Curved 29-3/8" Unframed		

**NOTES:**

- This front panel kit is designed for and approved only for use with Wolf Warming Drawer (WWD30).
- These handle kits are designed for use with a Wolf Integrated Front Panel Kit #808152
- Please read these instructions carefully before beginning installation.
- For any additional information, refer to the Use and Care Information and Installation instructions included with model WWD30.

CONTAINS:	ITEM	QTY	DESCRIPTION	ITEM	QTY	DESCRIPTION
	A	4	Bolt, #10-24 x 3/4"	H	4	Bolt, #8-32 x 1 1/4"
	B	4	Bolt, #10-24 x 1"	I	4	Bolt, #8-32 x 1 3/4"
	C	4	Bolt, #10-24 x 1-1/4"	J	4	Bolt, #8-32 x 2 1/2"
	D	4	Bolt, #10-24 x 1-3/4"	K	4	Washer, 1/4 x 5/8"
	E	4	Bolt, #10-24 x 2-1/4"	L	2	Stud, Mounting
	F	4	Bolt, #8-32 x 5/8"		1	Instructions
	G	4	Bolt, #8-32 x 1"			

See Fastener Reference Diagram Below:

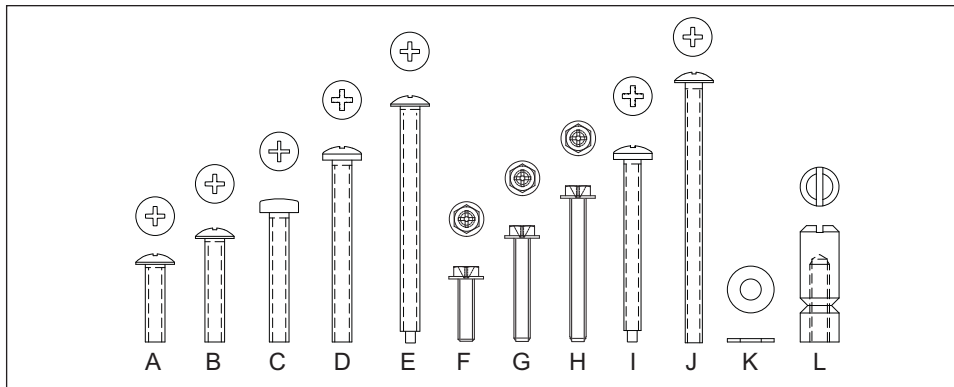

**Fastener Reference**

# 802781, 802782, 802783, 812340, 812341, 812342, 814020, 815837, 820395 Warming Drawer Handle Installation Instructions

## INSTALLATION PROCEDURE:

### 1" Tubular Handles

(Kits 802781, 802782, 802783):

1. Mark custom panel to locate the drill holes using the center-line dimensions from Figure 1. Drill four (4) 7/32" to 1/4" holes.
2. Counter bore 5/8" holes to 5/32" deep so that you can completely recess the head of the bolt and washer (See Figure 2).
3. Insert appropriate length bolts (two 1/4" bolts, but may vary depending on panel thickness) with washer(s) through holes into handle (See Figure 2).
4. Tighten the bolts to secure the handle to cabinet panel.
5. Proceed with panel attachment instructions included with the WWD flush mount panel kit.

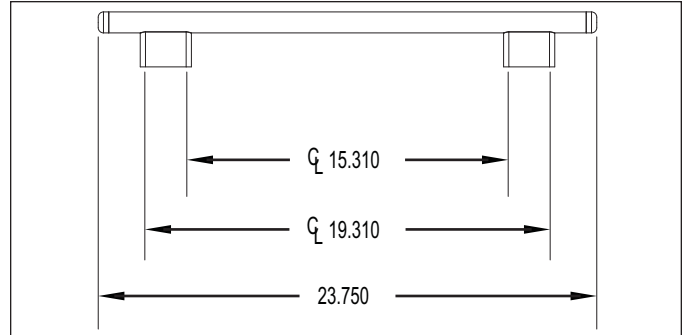

**Figure 1. 1" Handle Dimensions**

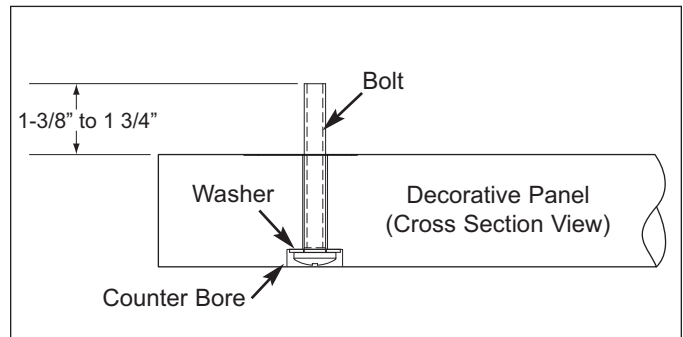

**Figure 2. Decorative Panel Prep for Handle**

### 3/4" Tubular Handle Framed & Unframed

(Kits 814020, 815837, 820395):

1. Mark custom panel to locate the drill holes using the center-line dimensions from Figures 3 or 4. Drill four (4) 7/32" to 1/4" holes.

(CONTINUED ON NEXT PAGE)

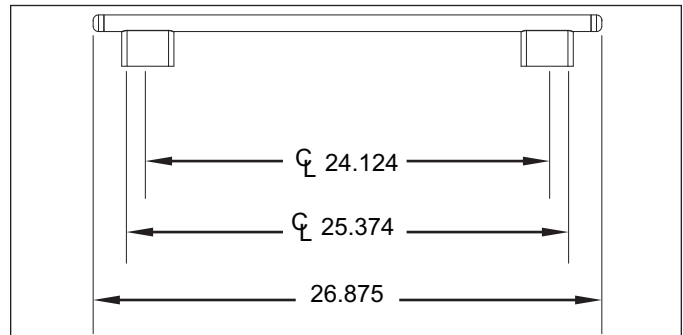

**Figure 3. 3/4" Framed Handle Dimensions**

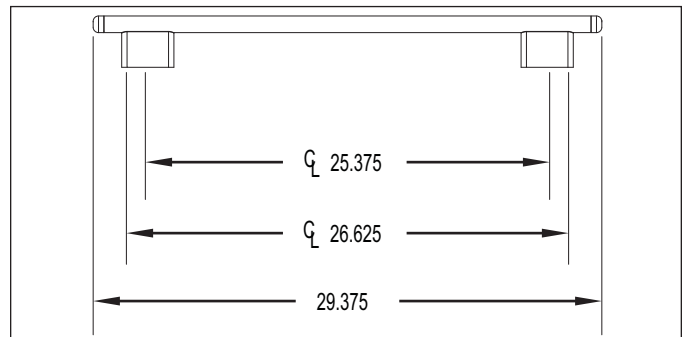

**Figure 4. 3/4" Unframed Handle Dimensions**

## 802781, 802782, 802783, 812340, 812341, 812342, 814020, 815837, 820395 Warming Drawer Handle Installation Instructions

2. The panel should be counter bored so that when an appropriate length bolt and washer are put in the hole, between 1-3/8" to 1-3/4" of thread is exposed on the face side of panel to hold the handle (See Figure 4).
3. Be sure that there is enough material removed with the counter bore that the bolt head surface is completely recessed into the cabinet panel (See Figure 4).
4. A different length bolt or additional washers may be required to achieve the proper amount of shown thread depending on the thickness of your custom panel.
5. Proceed with panel attachment instructions included with the WWD flush mount panel kit.

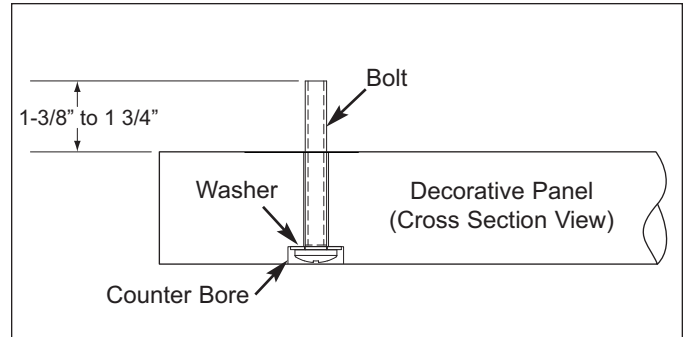

**Figure 4. Decorative Panel Prep for Handle**

### Pro Series Handle (Kit 812342):

1. Mark custom panel to locate the drill holes using the center-line dimensions from Figure 5. Drill two (2) 7/32" to 1/4" holes
2. Counter bore 5/8" holes to 5/32" deep so that you can completely recess the head of the bolt and washer (See Figure 6).
3. Insert appropriate length bolts with washer(s) through holes and thread the mounting studs onto the bolts (be sure that the bolt is not bottomed out in the mounting stud) and tighten (See Figure 6).
4. Insert pro series handle onto mounting studs and secure with the set screws
5. Proceed with panel attachment instructions included with the WWD flush mount panel kit.

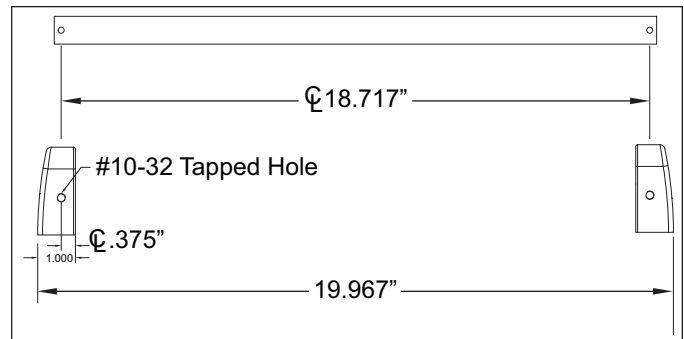

**Figure 5. Pro Handle Dimensions**

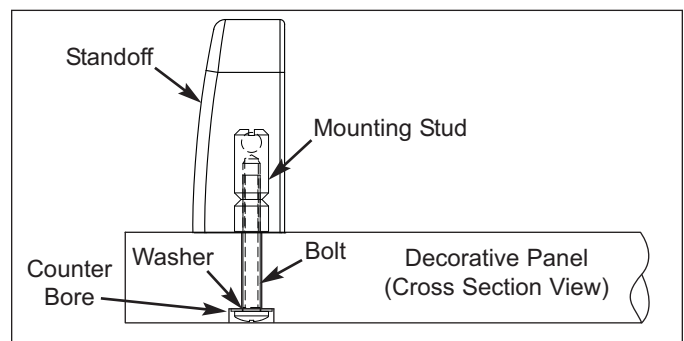
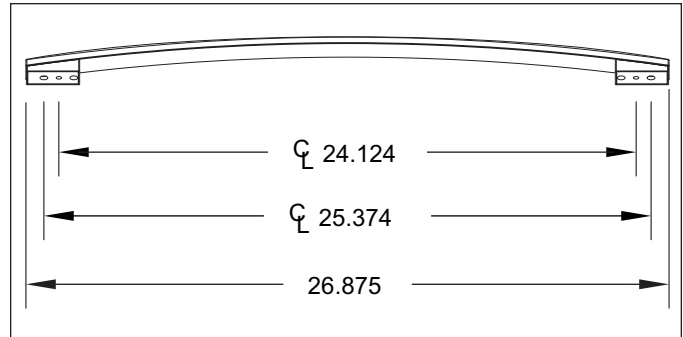

**Figure 6. Decorative Panel Prep for Handle**

# 802781, 802782, 802783, 812340, 812341, 812342, 814020, 815837, 820395 Warming Drawer Handle Installation Instructions

## Curved Handles Framed & Unframed (Kits 812340, 812341):

1. Mark custom panel to locate the drill holes using the center-line dimensions from Figures 7 or 9. Drill four (4) 7/32" to 1/4" holes.  
**NOTE:** Countersink procedure is critical for this application. Damage may occur to the handle if these instructions are not followed precisely.
2. The handle mounting holes should be counter bored (5/8" diameter to 5/32") so that when an appropriate length #8-32 bolt and washer are put in the hole, there will be a proper amount of thread visible on the face side of the panel to hold the handle without causing damage (See Figures 8 or 10) for the visible thread requirements).
3. Be sure that there is enough material removed with the counter bore that the bolt head surface is completely recessed into the cabinet panel.
4. A different length bolt or additional washers may be required to achieve the proper amount of shown thread depending on the thickness of your custom panel.
5. Proceed with panel attachment instructions included with the WWD flush mount panel kit.



**Figure 7. Curved Framed Handle Dimensions**

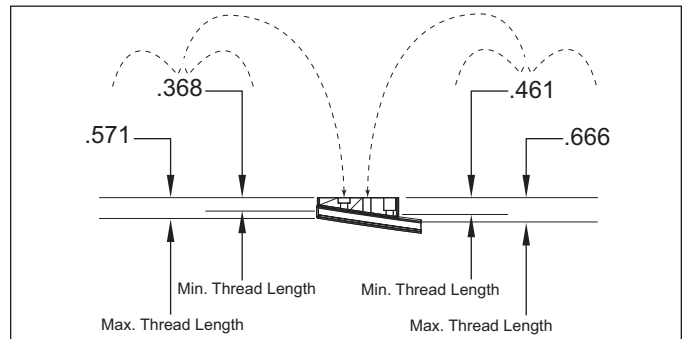

**Figure 8. Decorative Panel Prep for Handle**

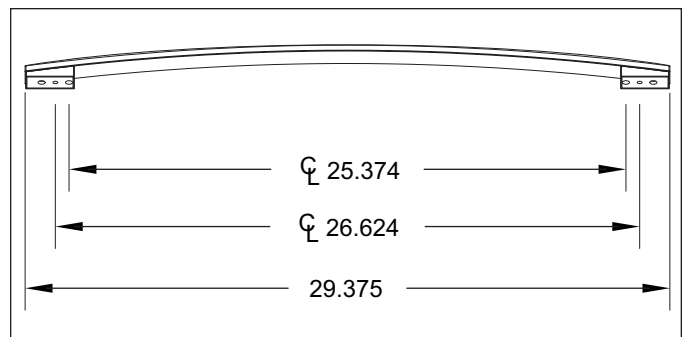

**Figure 9. Curved Unframed Handle Dimensions**

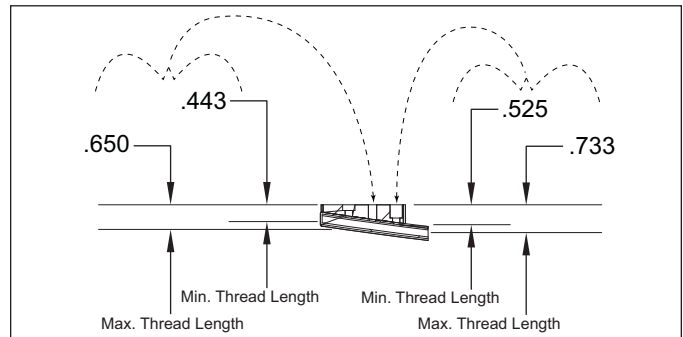

**Figure 10. Decorative Panel Prep for Handle**