

RC462705

RC472705

RC492705

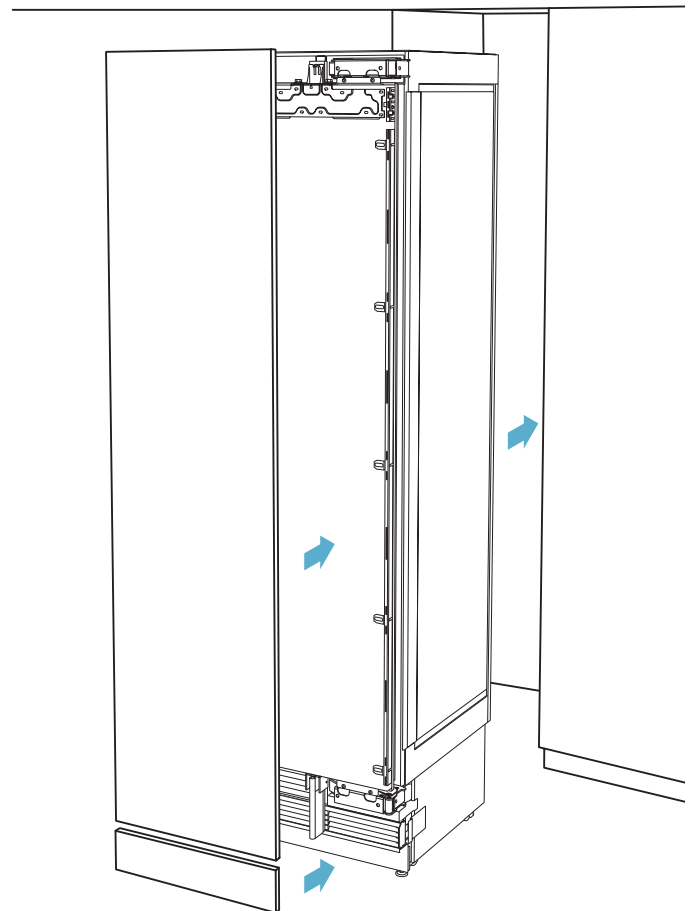

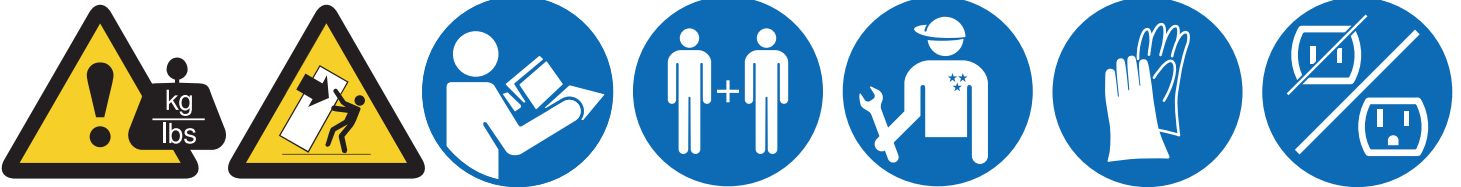

About these instructions

- Read and follow the operating and installation instructions. They contain important information on how to install, use and maintain the appliance.
- The manufacturer is not liable if you disregard the instructions and warnings in the operating and installation instructions.
- Have the appliance installed by the manufacturer, customer service or a similarly qualified person only.
- Retain all documents for subsequent use or for the next owner.

Risk of electric shock

Improper installations and repairs may put the user at considerable risk.

- Never cut through or remove the third (ground) conductor of the power cord.
- Never use extension cords or multiple plugs.
- Never use adapters.
- If the power cord is damaged:
Immediately disconnect the appliance from the power supply and replace the power cord.
- Only use original parts supplied by the manufacturer.

Risk of suffocation

- Keep children away from the packaging and its parts.

Risk of injury

- Risk of tipping over! The appliance is very heavy/top-heavy. The appliance should always be transported and set up by at least 2 people.
- Risk of tipping over! The appliance is very heavy/top-heavy. The appliance must be secured with the anti-tip brackets supplied and continuously supervised during this operation.
- Danger of cut injuries! Always wear protective gloves while installing the appliance.

Damage

To prevent damage:

- Do not stand or support yourself on the base, runners or doors.
- Keep plastic parts and door seals free of oil and grease.

State of California Proposition 65 Warnings

This product may contain a chemical known to the State of California, which can cause cancer or reproductive harm. Therefore, the packaging of your product may bear the following label as required by California:

**STATE OF CALIFORNIA PROPOSITION 65 WARNING: /
AVERTISSEMENT ISSUE DE LA PROPOSITION 65
DE L'ÉTAT DE LA CALIFORNIE:**

 **WARNING /
AVERTISSEMENT**

Cancer and Reproductive Harm / Cancer et dommages à la reproduction - www.P65Warnings.ca.gov.

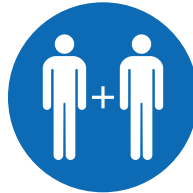

À propos de cette notice

- Veuillez lire et respecter le contenu de cette notice d'utilisation et de montage. Elle contient des remarques importantes concernant l'installation, l'utilisation et l'entretien de l'appareil.
- Le fabricant décline toute responsabilité si vous ne tenez pas compte des remarques et avertissements figurant dans la notice de montage et celle d'utilisation.
- Ne confiez l'installation qu'au fabricant, au service à la clientèle ou à une personne présentant une qualification équivalente.
- Veuillez conserver tous ces documents en vue d'une réutilisation ultérieure ou pour le cas où l'appareil changerait de propriétaire.

Risque d'électrocution

Toute installation ou réparation incorrecte peut engendrer des risques considérables pour l'utilisateur.

- Ne sectionnez ni ne retirez jamais le troisième conducteur (conducteur de mise à la terre) du cordon d'alimentation.
- N'utilisez pas de câble de rallonge ou de connecteur multiple.
- N'utilisez pas d'adaptateur.
- Si le cordon d'alimentation est endommagé : débranchez immédiatement l'appareil du secteur et remplacez le cordon d'alimentation.
- N'utilisez que des pièces de rechange d'origine venant du fabricant.

Risque d'asphyxie

- Ne confiez jamais l'emballage et ses pièces constitutives aux enfants.

Risque de blessure

- Risque de basculement! L'appareil est très lourd et son poids est inégalement réparti. Il faut être au moins 2 deux personnes pour installer et transporter l'appareil.
- Risque de basculement! L'appareil est très lourd et son poids est inégalement réparti. L'appareil doit être stabilisé avec les équerres antibasculement fournies, avant quoi il doit demeurer sous supervision constante.
- Risque de coupures! Portez des gants de protection durant l'installation.

Dégâts matériels

Pour éviter des dégâts matériels :

- Ne vous servez jamais du socle, des glissières ou des portes comme marchepieds et ne vous appuyez jamais dessus.
- Veillez à ce que les pièces en matière plastique et les joints de porte soient exempts d'huile et de graisse.

Avertissements de la Proposition 65 de l'État de la Californie

Ce produit pourrait contenir un produit chimique reconnu par l'État de la Californie comme cancérigène ou ayant des effets nocifs sur la reproduction. Par conséquent, l'emballage de votre produit pourrait porter l'étiquette suivante, comme requis par la Californie :

**STATE OF CALIFORNIA PROPOSITION 65 WARNING: /
AVERTISSEMENT ISSUE DE LA PROPOSITION 65
DE L'ÉTAT DE LA CALIFORNIE:**



**WARNING /
AVERTISSEMENT**

Cancer and Reproductive Harm / Cancer et dommages à la reproduction - www.P65Warnings.ca.gov.

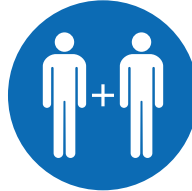

Acerca de este manual

- Lea y siga las instrucciones de uso y de montaje. Ellas contienen información importante sobre la instalación, uso y mantenimiento del aparato.
- El fabricante no se hace responsable, si usted ignora las indicaciones y advertencias de las instrucciones de uso y montaje.
- El aparato sólo debe ser instalado por el fabricante, por el personal de servicio al cliente o por una persona con una cualificación similar.
- Guarde todas las instrucciones de uso y de montaje para futuras consultas y posteriores propietarios.

Peligro de descarga eléctrica

Una instalación o reparación incorrecta puede poner al usuario en un riesgo considerable.

- Nunca corte o retire el tercer conductor (conductor a tierra) del cable de conexión a la red eléctrica.
- No utilizar cables de prolongación ni enchufes múltiples.
- Nunca use adaptadores.
- Si el cable de conexión a la red eléctrica está dañado, desenchufe el aparato de la toma de corriente inmediatamente y sustituya dicho cable de conexión.
- Utilizar únicamente piezas originales del fabricante.

Peligro de asfixia

- No dejar el embalaje o sus partes a los niños.

Peligro de lesiones

- ¡Peligro de vuelco! El aparato es muy pesado y tiene más peso en la parte superior. Realizar la instalación y el transporte del aparato siempre con un mínimo de 2 personas.
- ¡Peligro de vuelco! El aparato es muy pesado y tiene más peso en la parte superior. El aparato debe asegurarse con las escuadras de protección contra vuelco que se adjuntan y supervisarse continuamente hasta ese momento.
- ¡Peligro de heridas por corte! Llevar siempre guantes protectores durante la instalación.

Daños materiales

Para evitar daños materiales:

- No pise, ni se apoye sobre el zócalo, cajones o puertas.
- Mantenga las piezas de plástico y juntas de goma limpias de aceites y grasas.

Advertencias en virtud de la Proposición 65 del estado de California

Este producto puede contener un químico que el Estado de California reconoce como potencialmente cancerígeno o causante de daños reproductivos. Por tanto, su producto debe llevar en su embalaje la siguiente etiqueta de conformidad con la legislación de California:

STATE OF CALIFORNIA PROPOSITION 65 WARNING: /
AVERTISSEMENT ISSUE DE LA PROPOSITION 65
DE L'ÉTAT DE LA CALIFORNIE:



**WARNING /
AVERTISSEMENT**

Cancer and Reproductive Harm / Cancer et dommages à la
reproduction - www.P65Warnings.ca.gov.

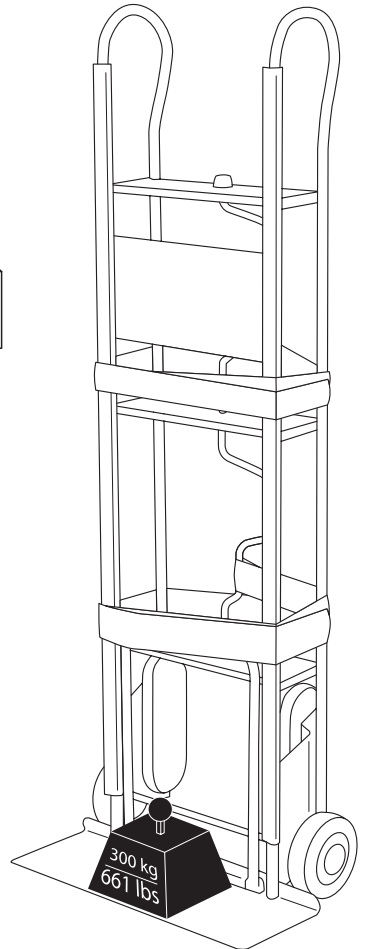
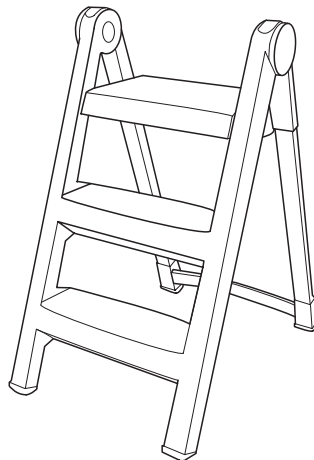
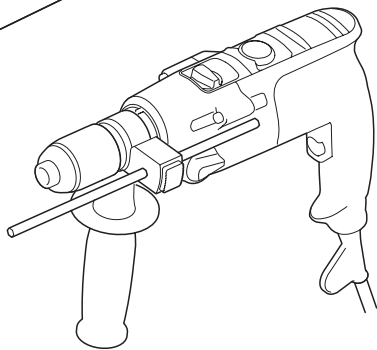
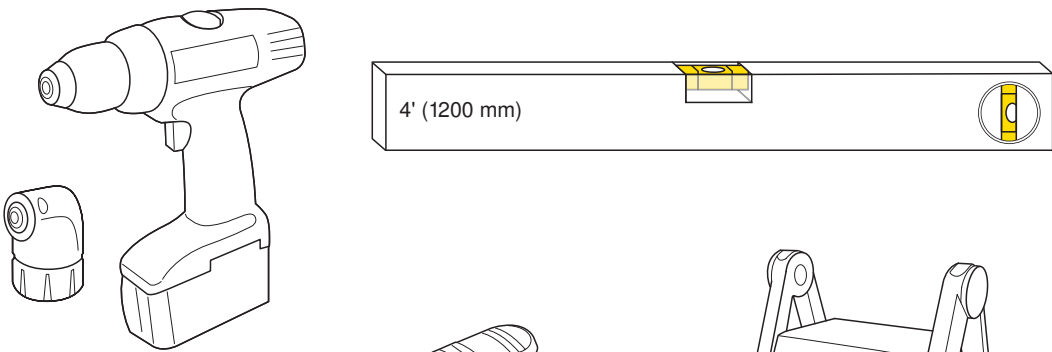
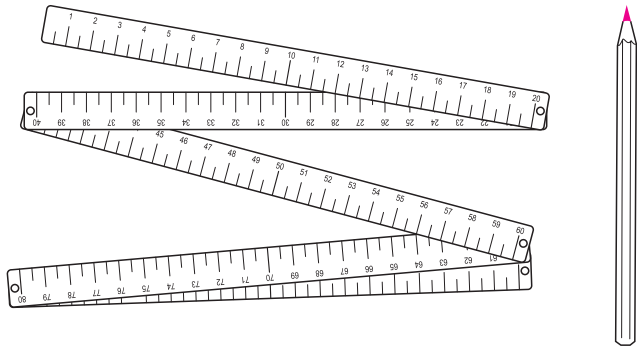
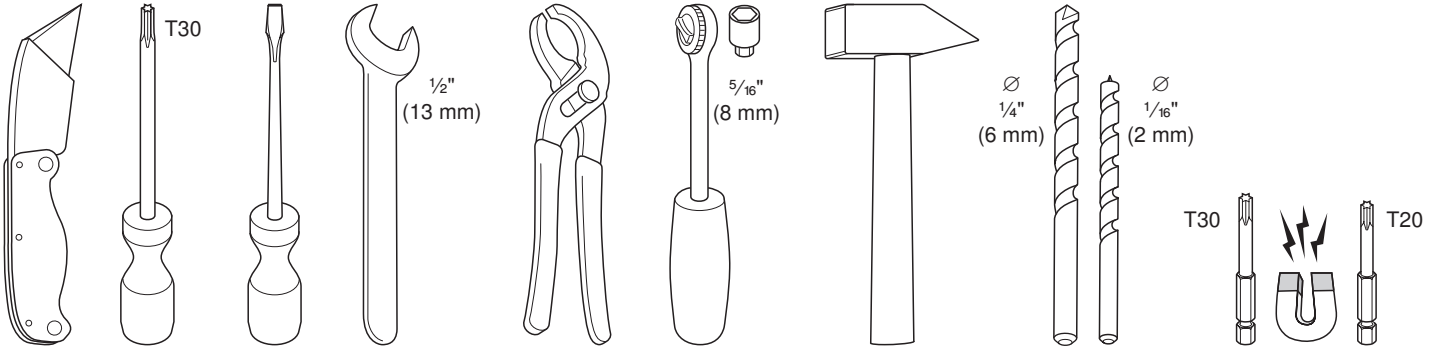
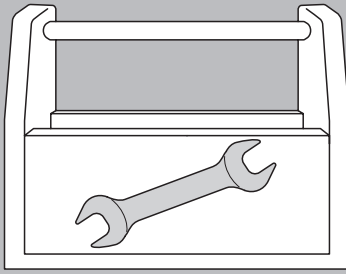

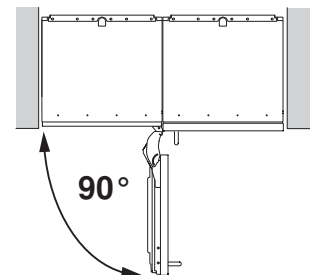
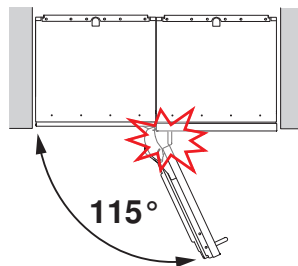
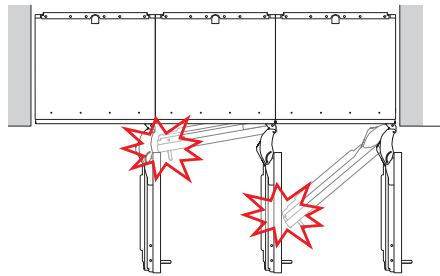
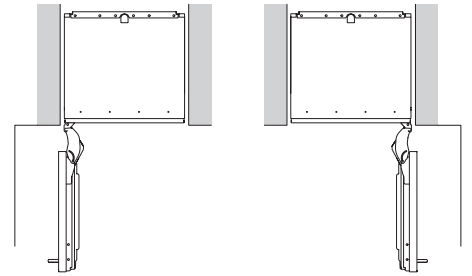
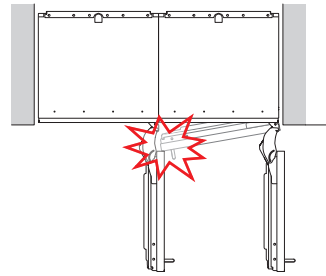
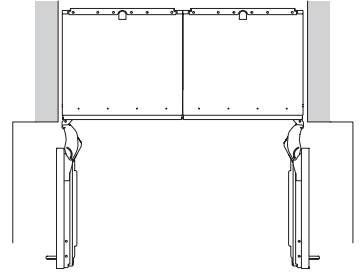
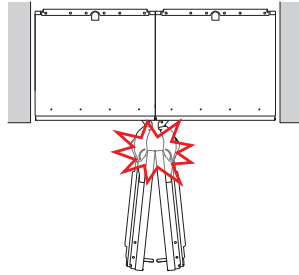
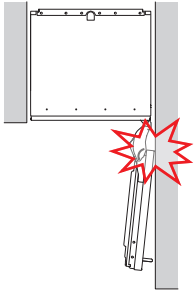



$\frac{5}{8}'' \leq b < 6\frac{1}{4}''$
(16 mm \leq b < 160 mm)

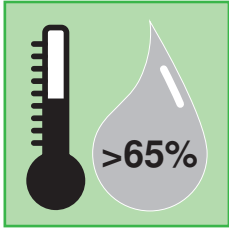

$a \geq 1\frac{3}{16}''$
(a \geq 30 mm)

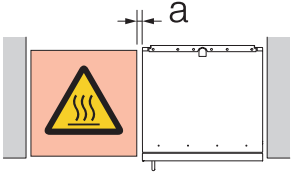

$b \geq 6\frac{1}{4}''$
 $b \geq 160$ mm

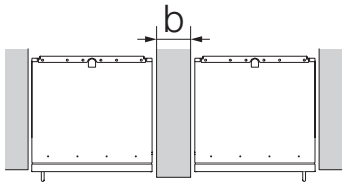
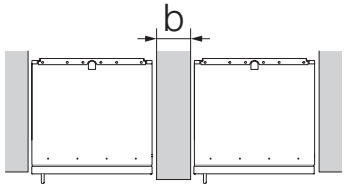
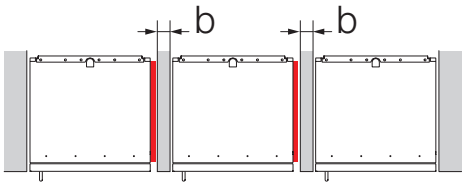
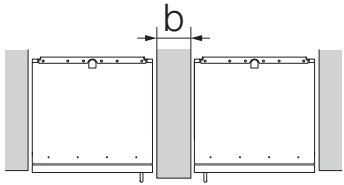
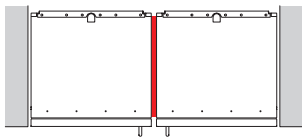
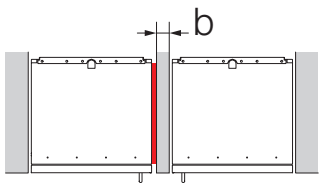

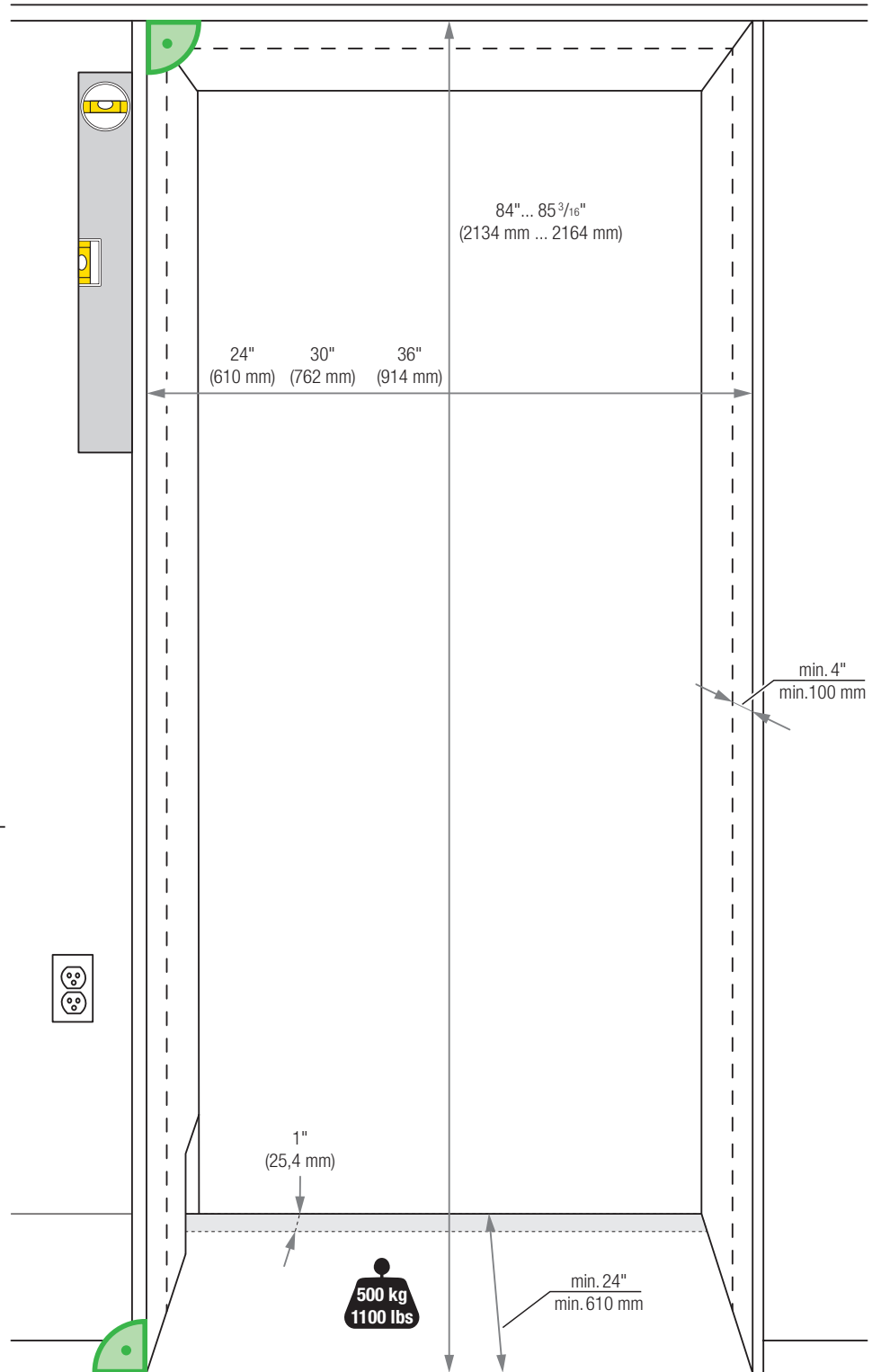
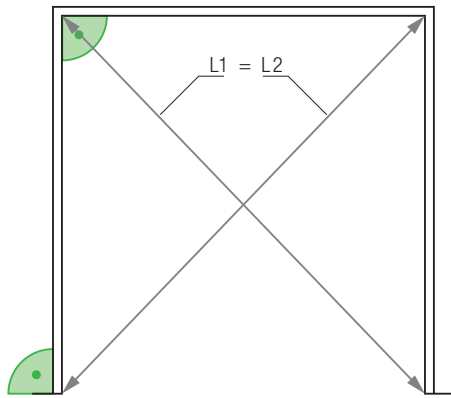

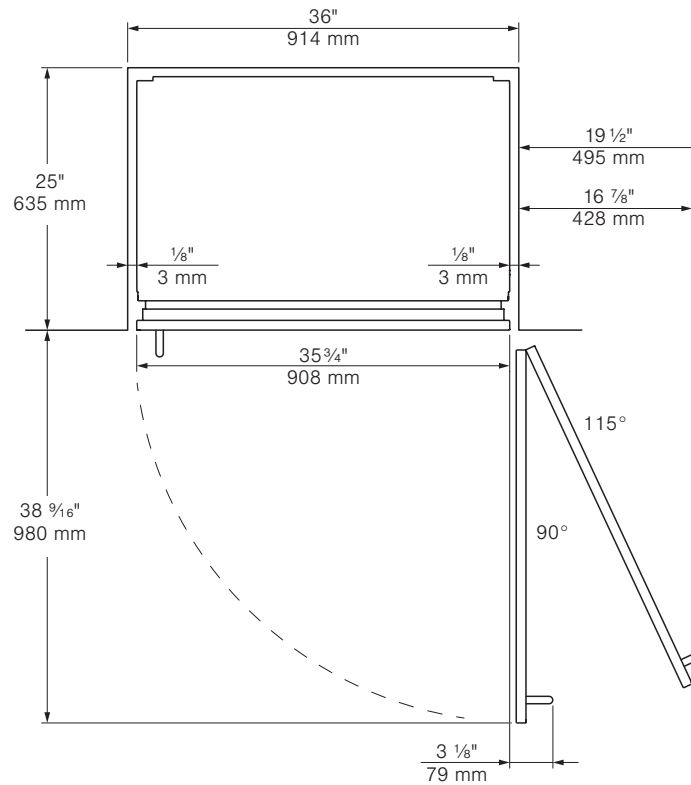
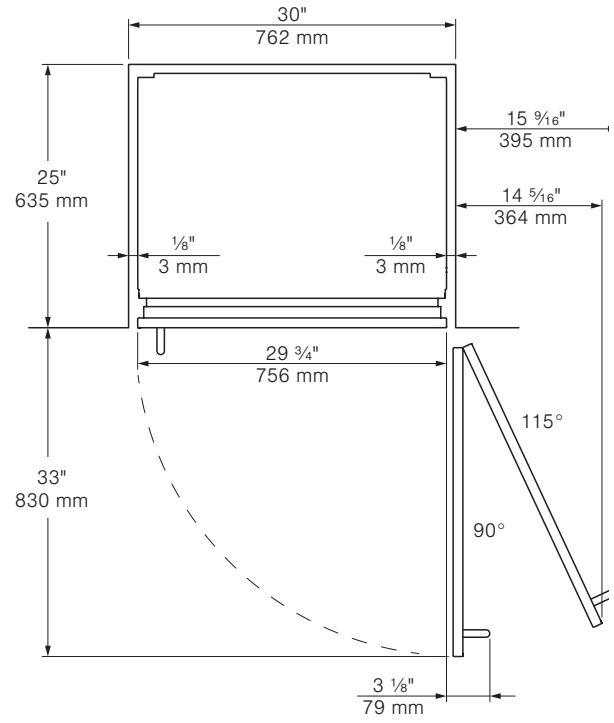
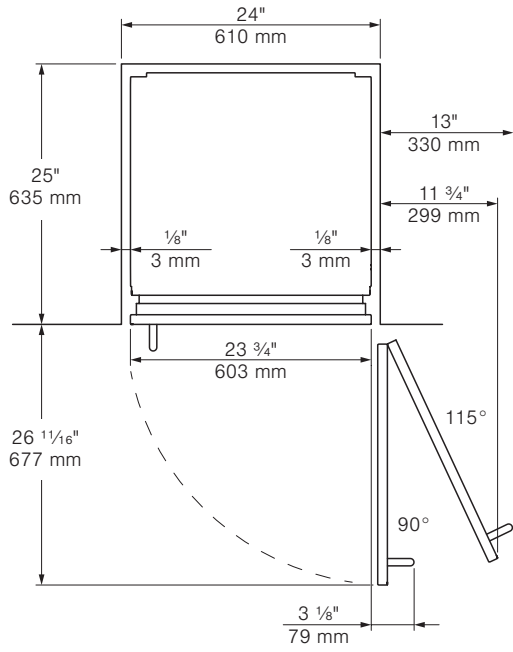

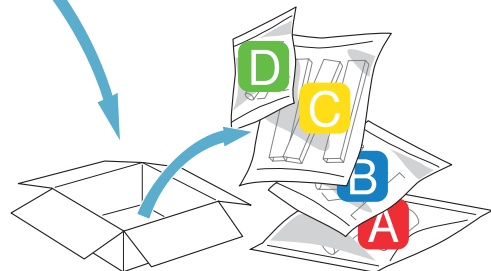
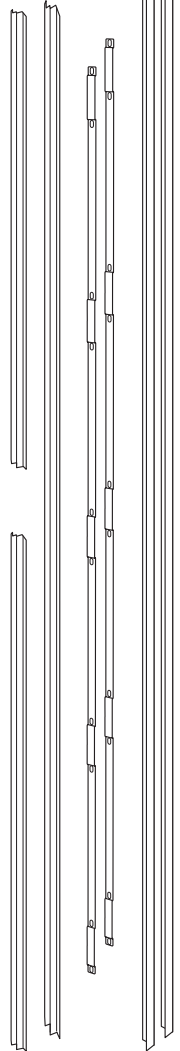
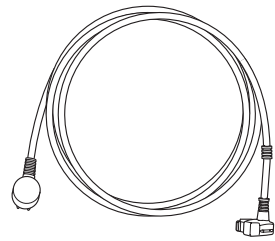
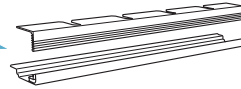
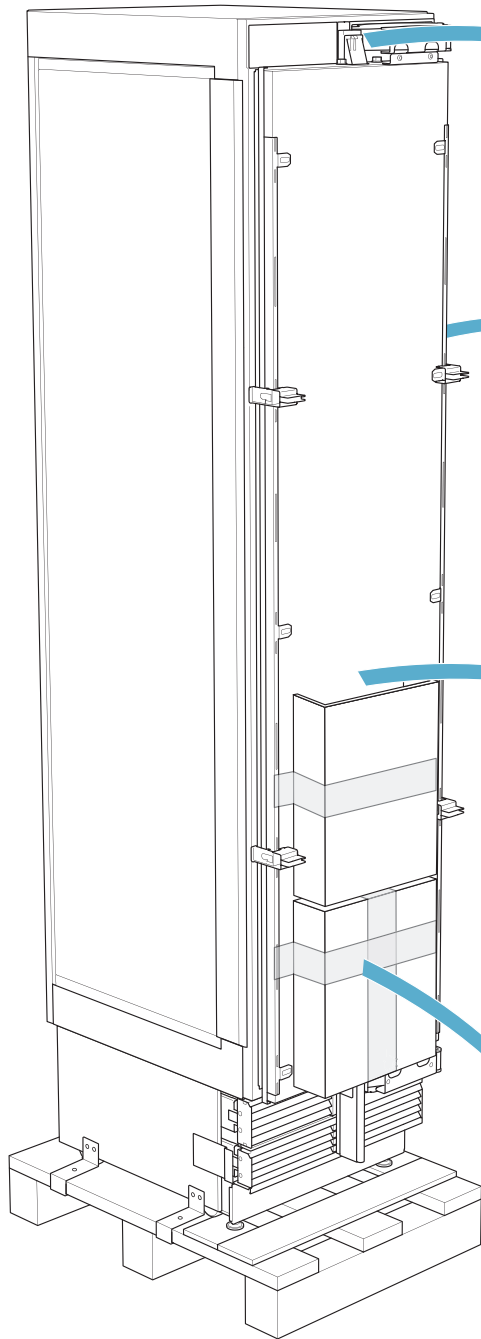
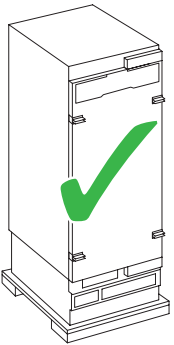
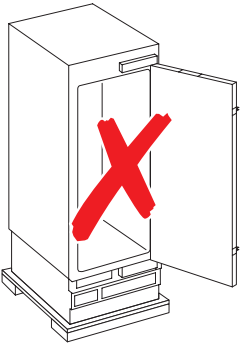
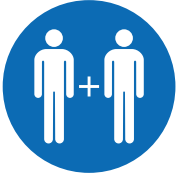

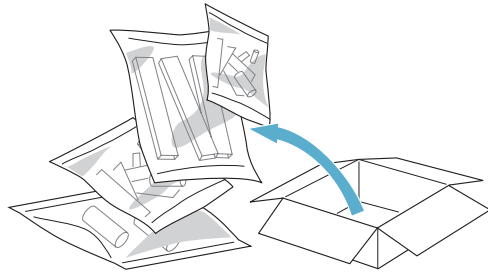



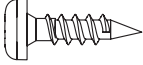

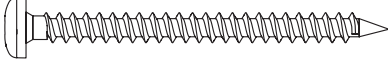
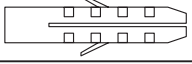
A

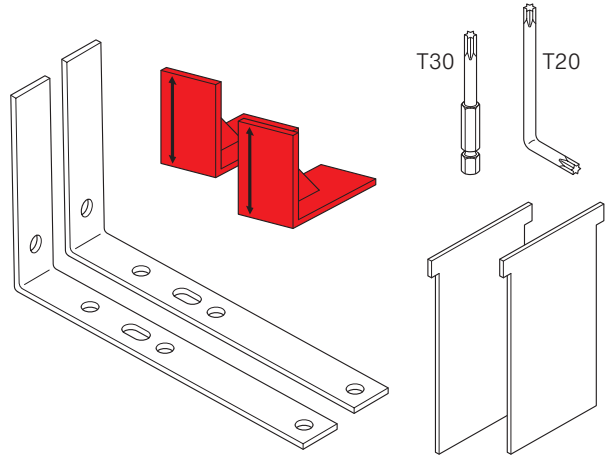



4x15			6x
5x60			4x
6x31			4x

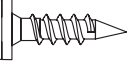

B

4x15			8x
------	---	---	----

C

4x15			32x
4x15			2x

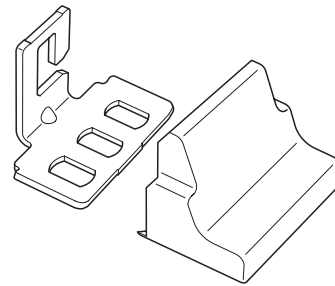

D

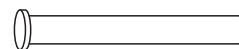

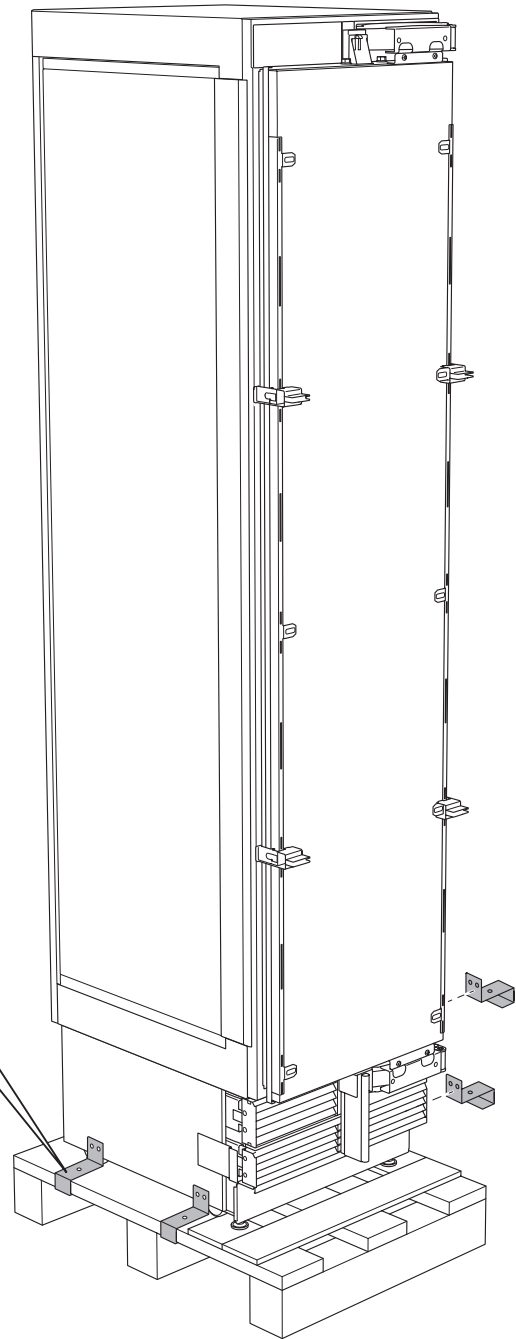
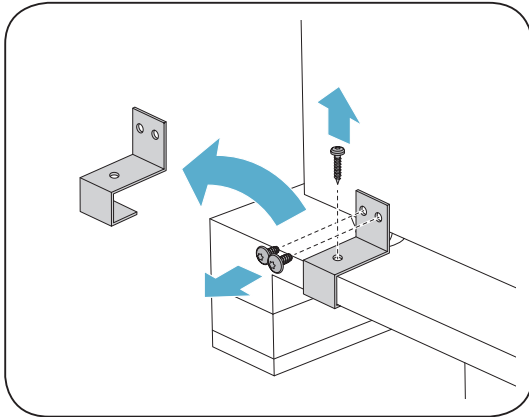
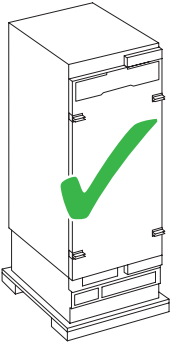
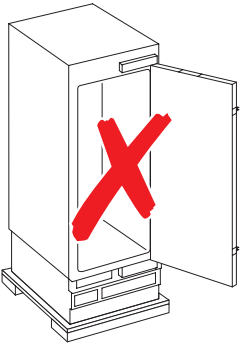
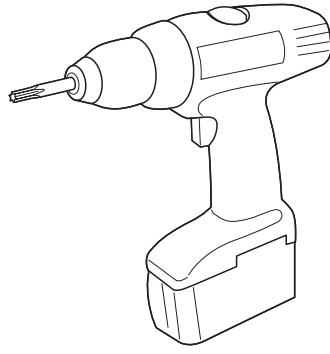
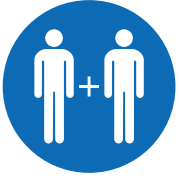

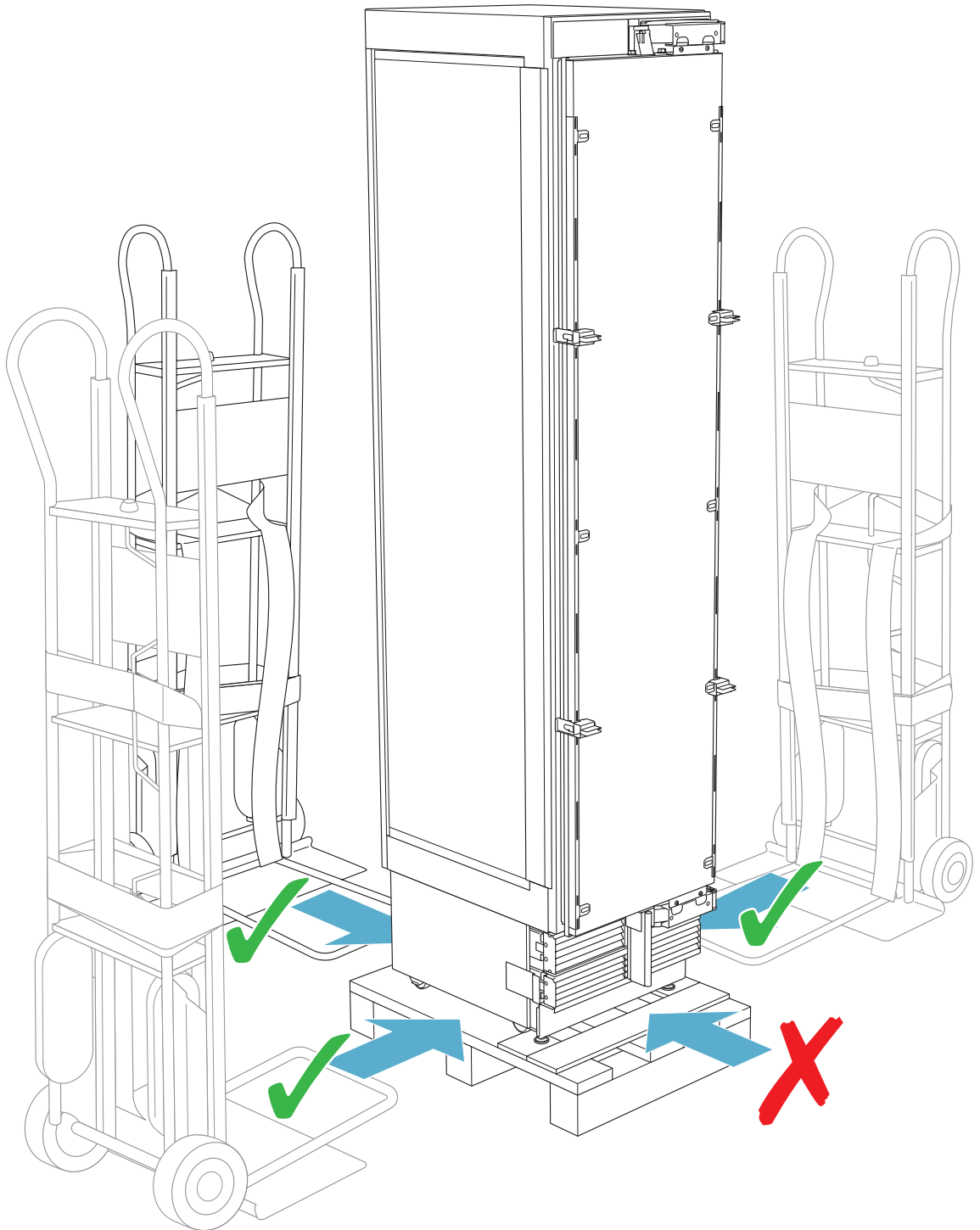
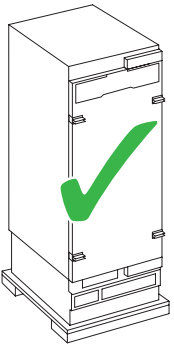
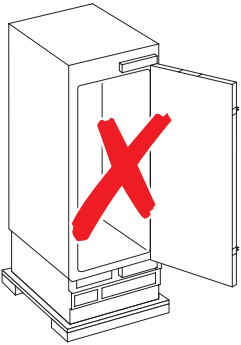
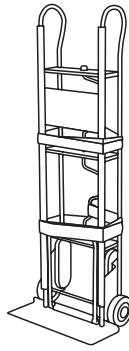
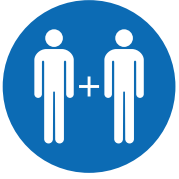

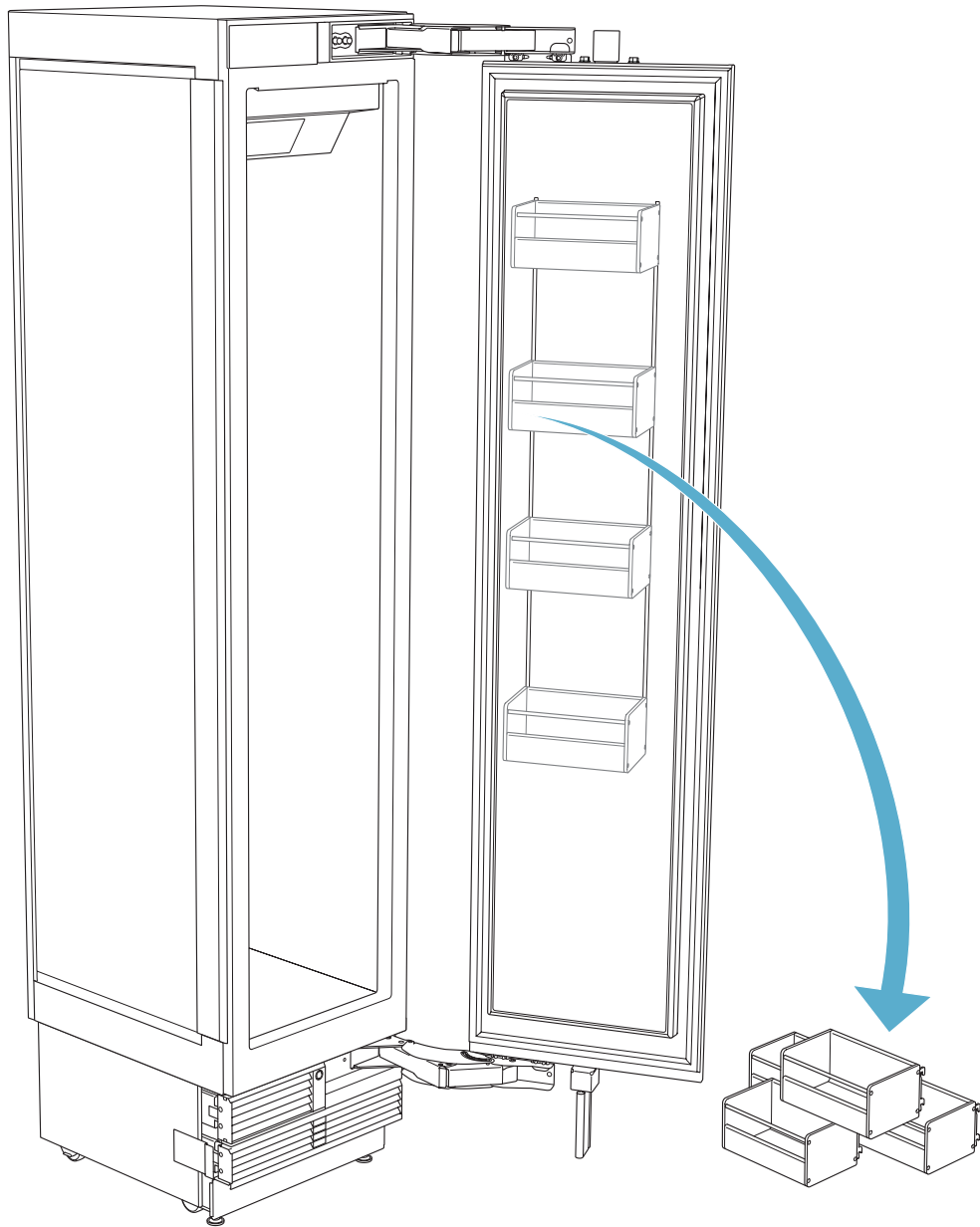
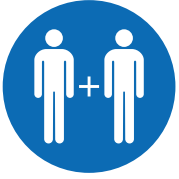

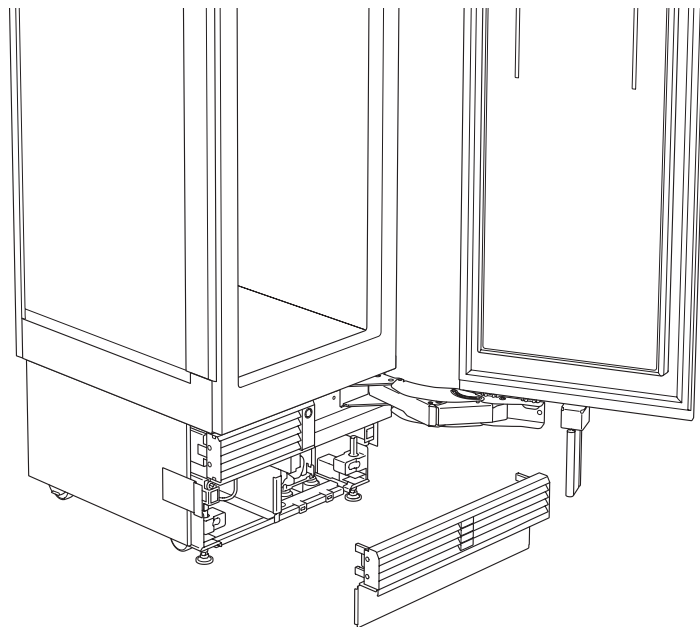
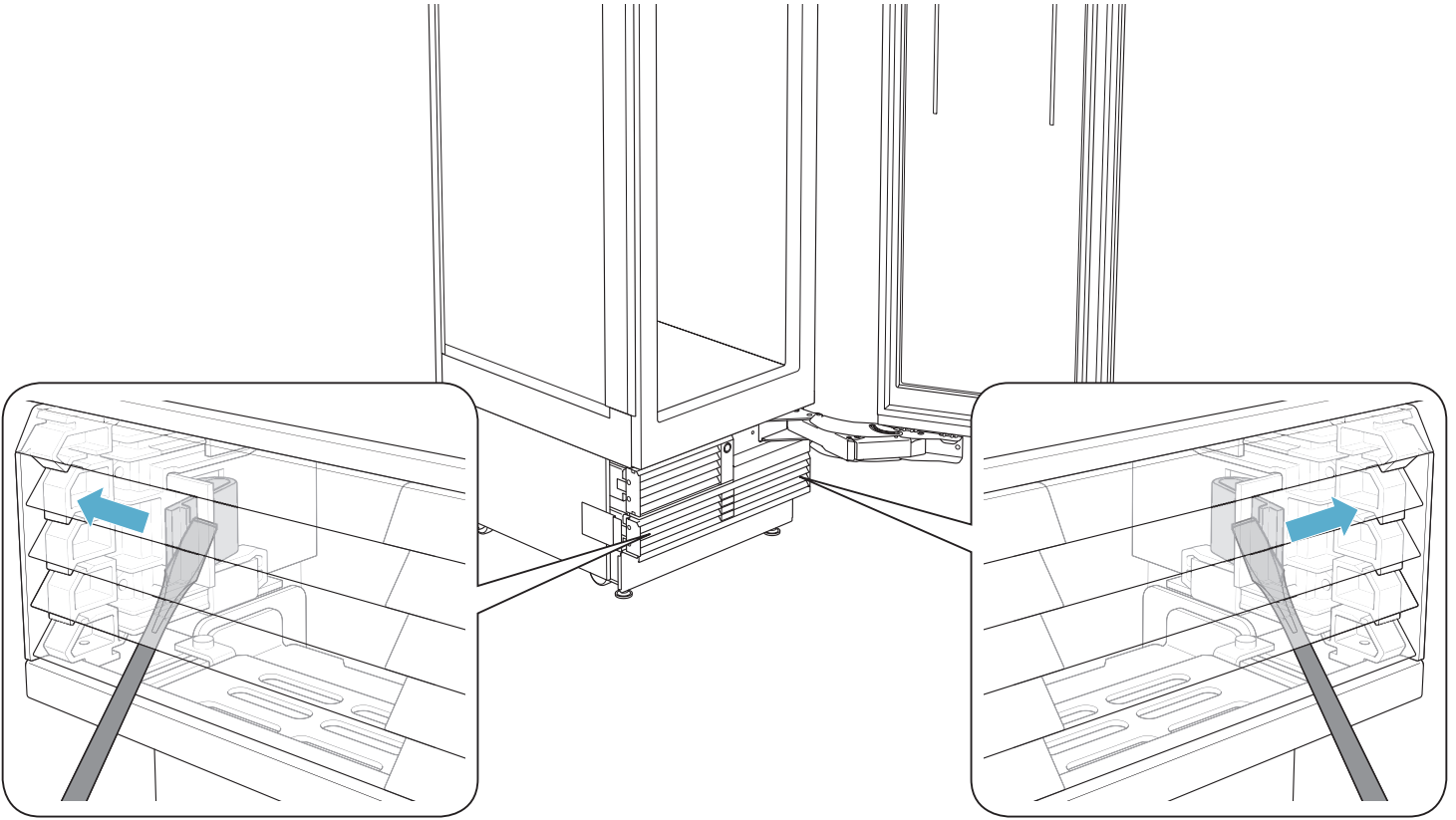
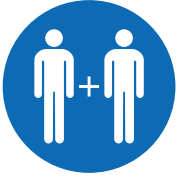

A

B

C

D

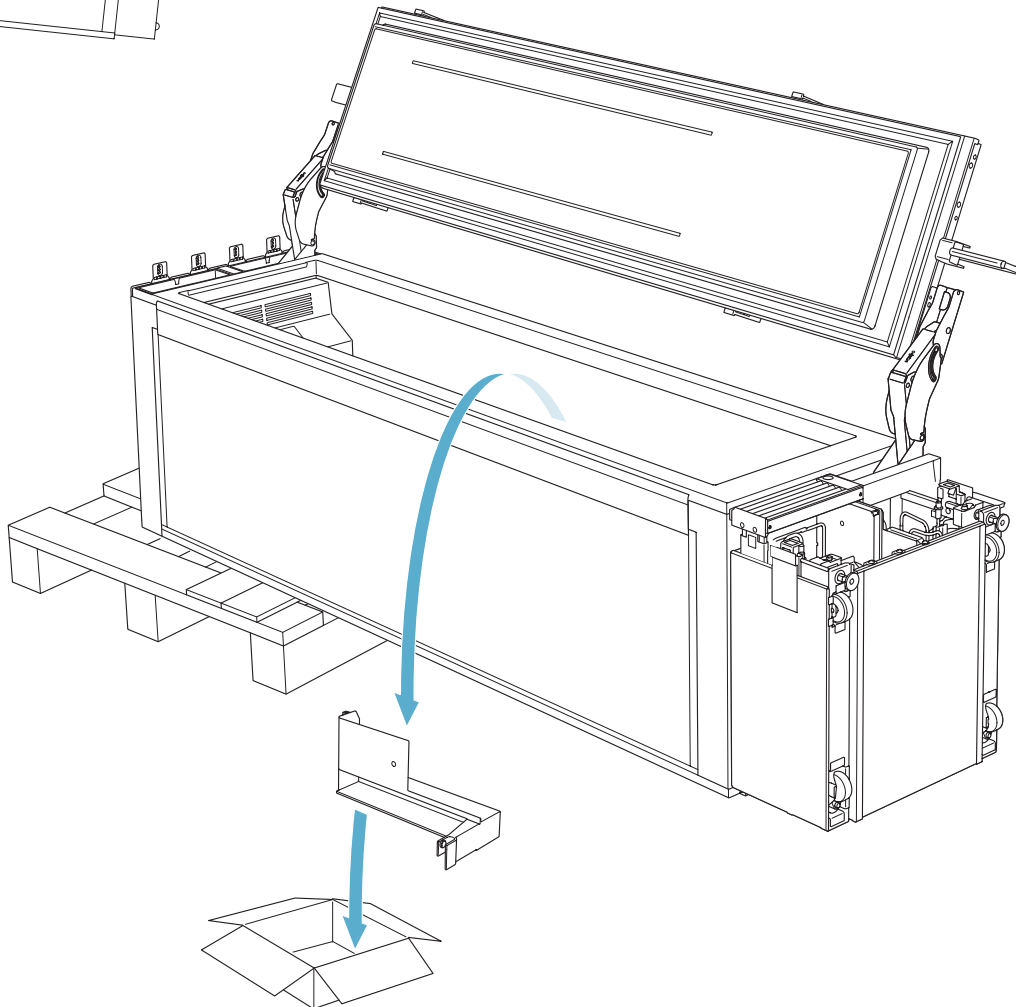
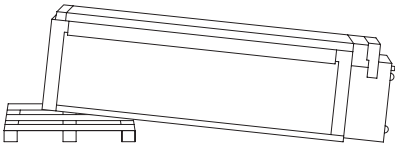
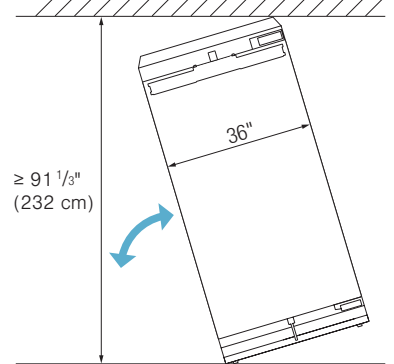
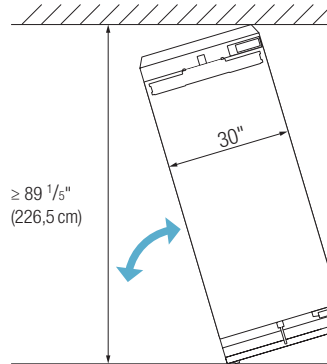
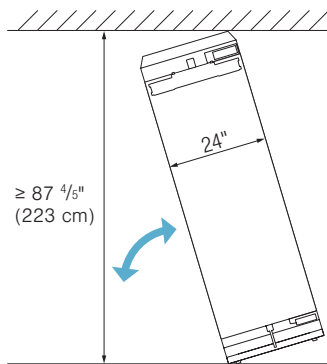
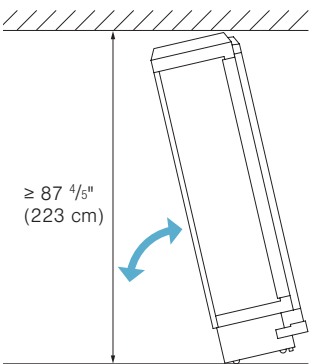
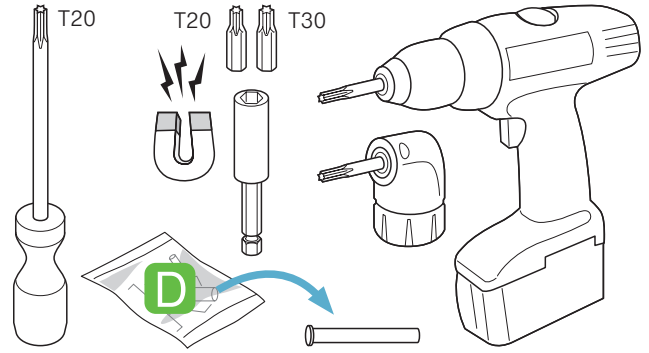
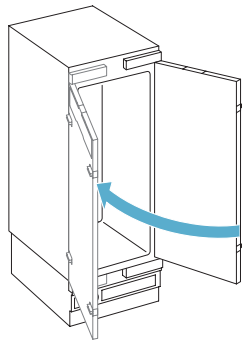
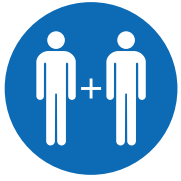

- A
- B
- C
- D

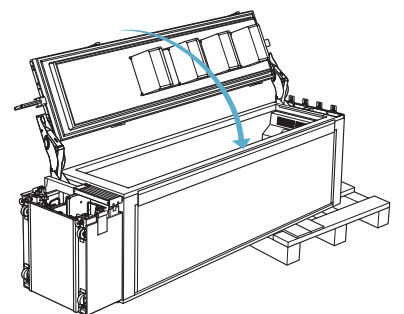
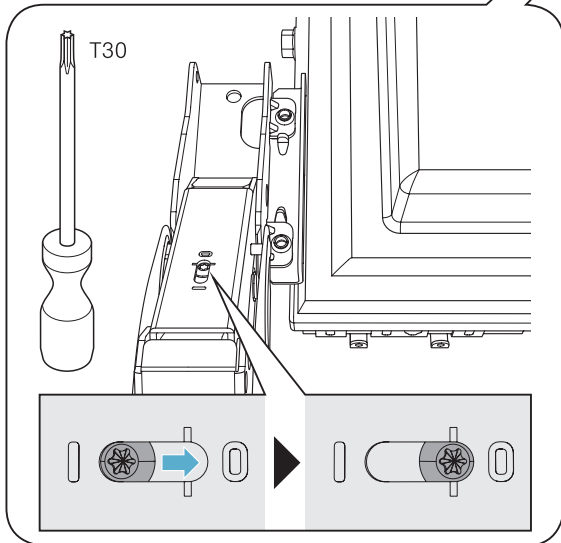
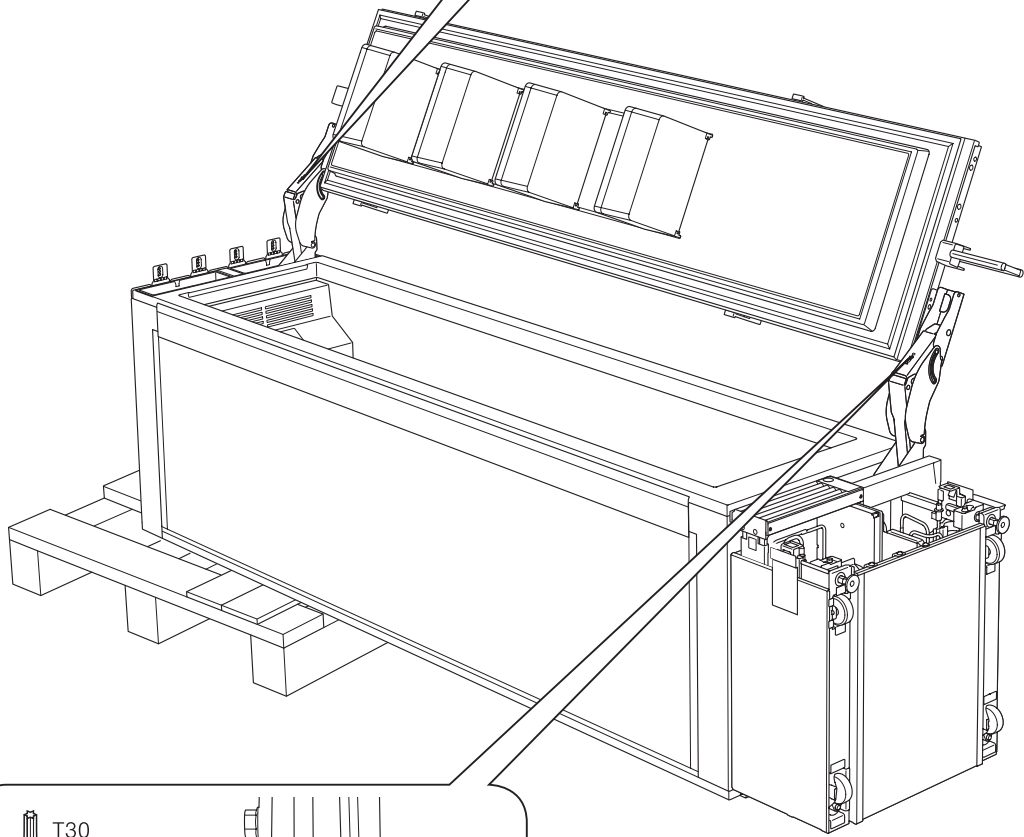
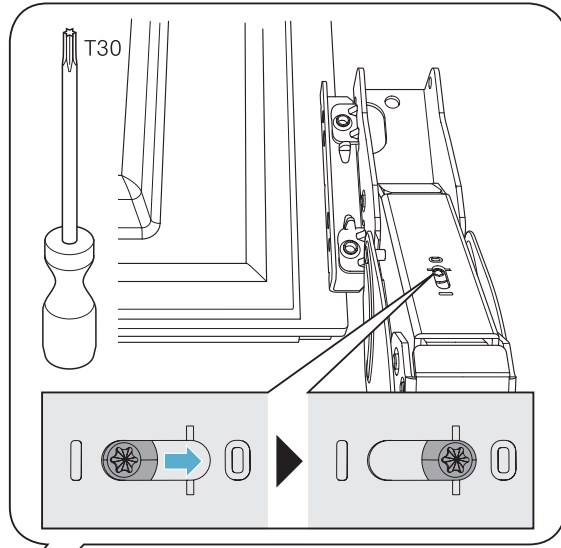
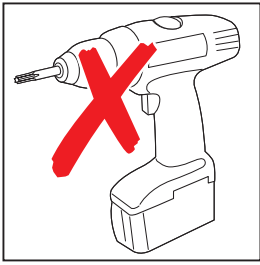

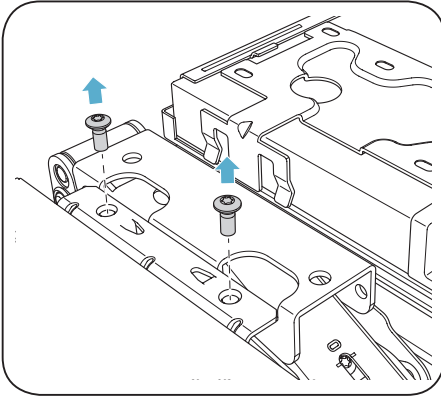

A

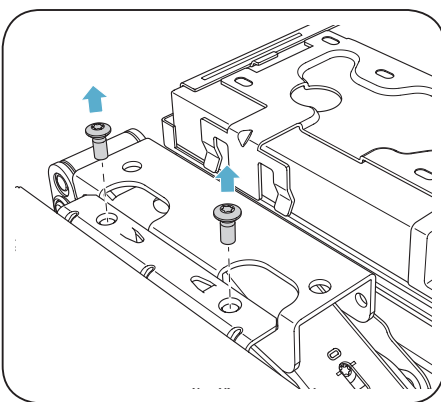
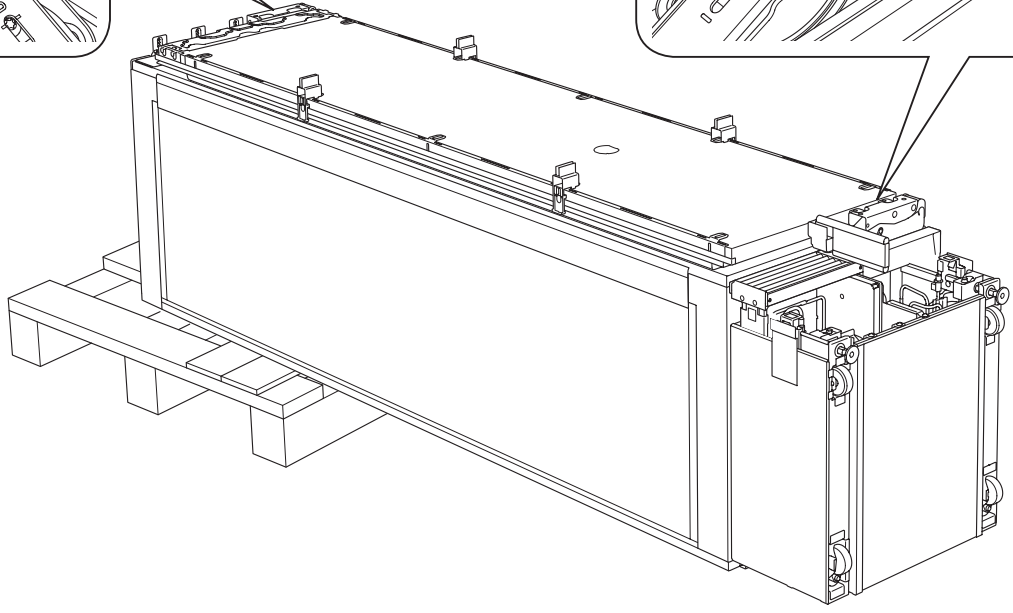
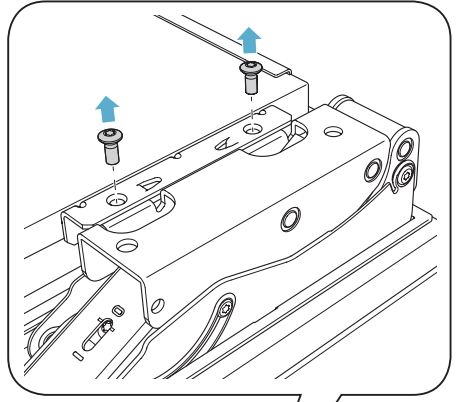

B

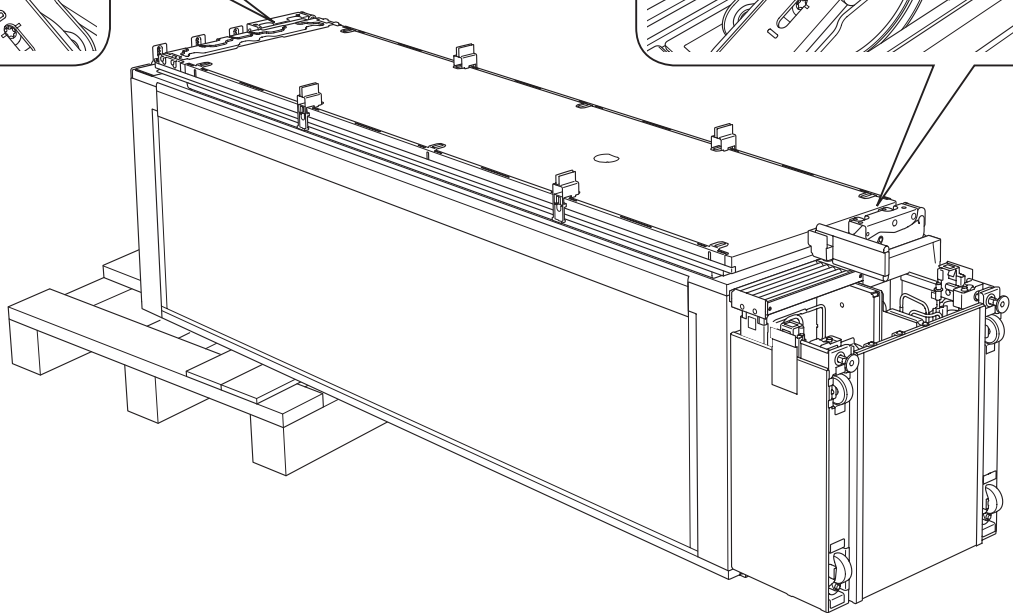
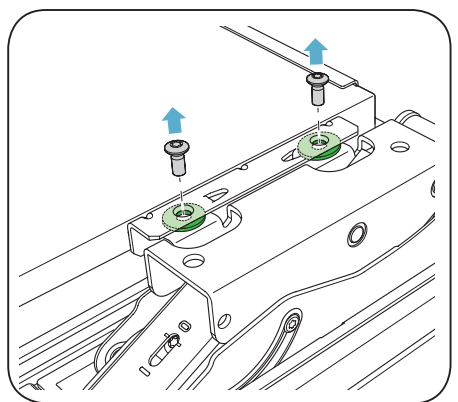

A
B
C
D

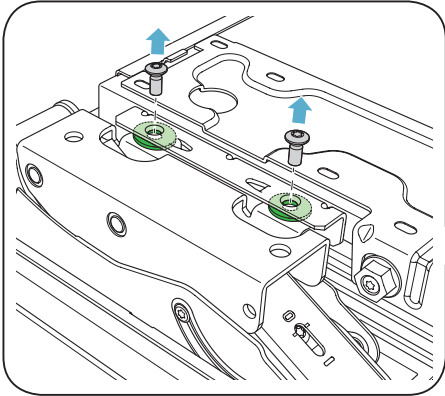

C

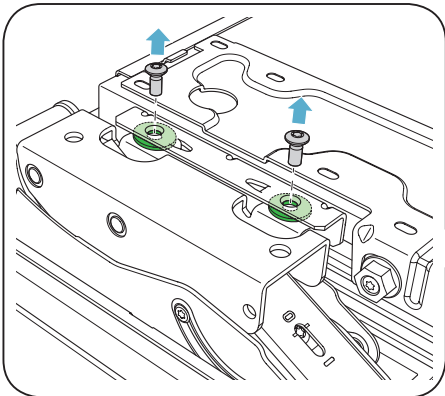
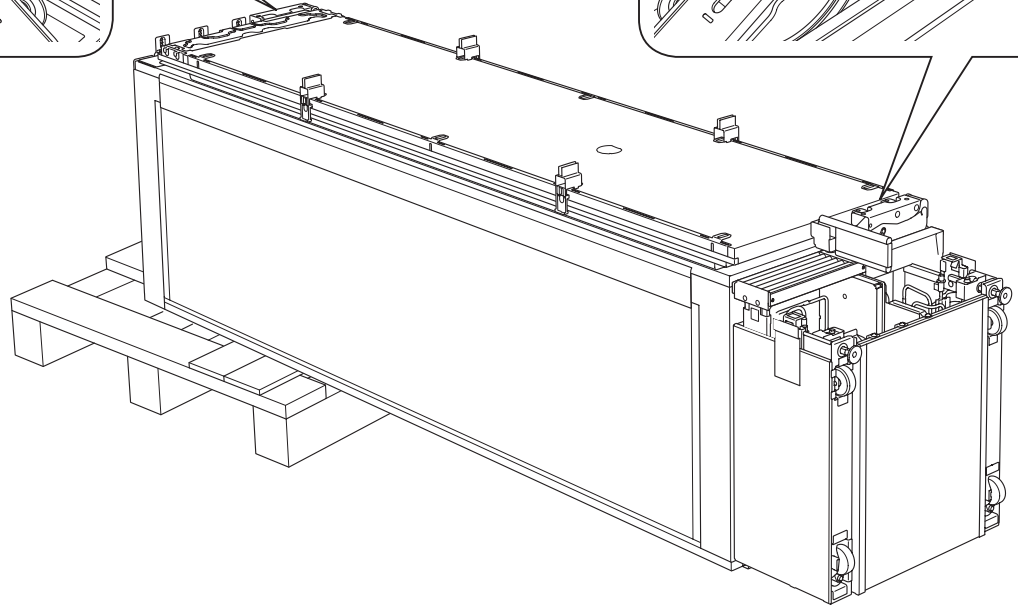
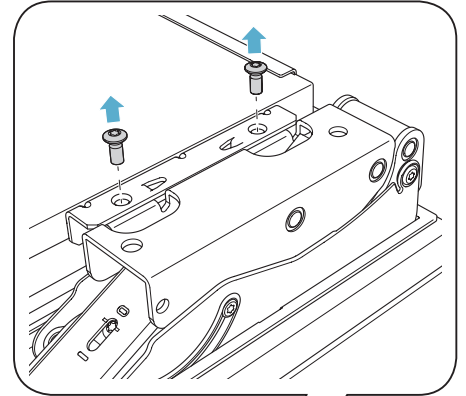

D

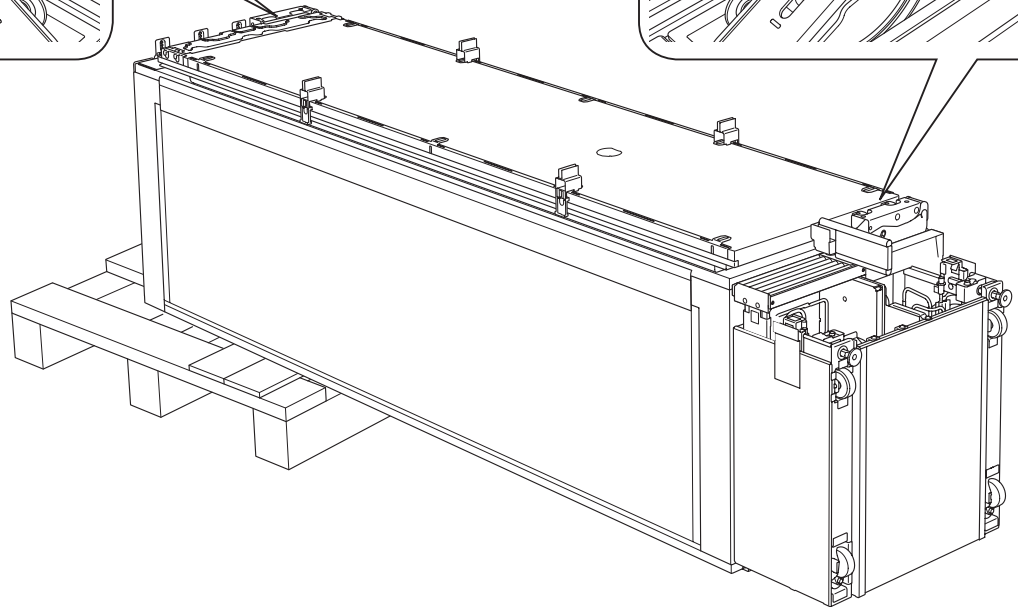
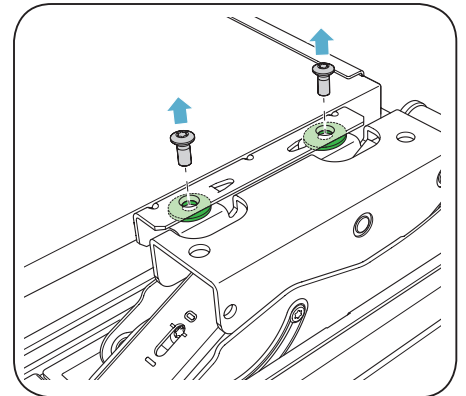
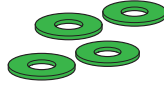

A

B

C

D

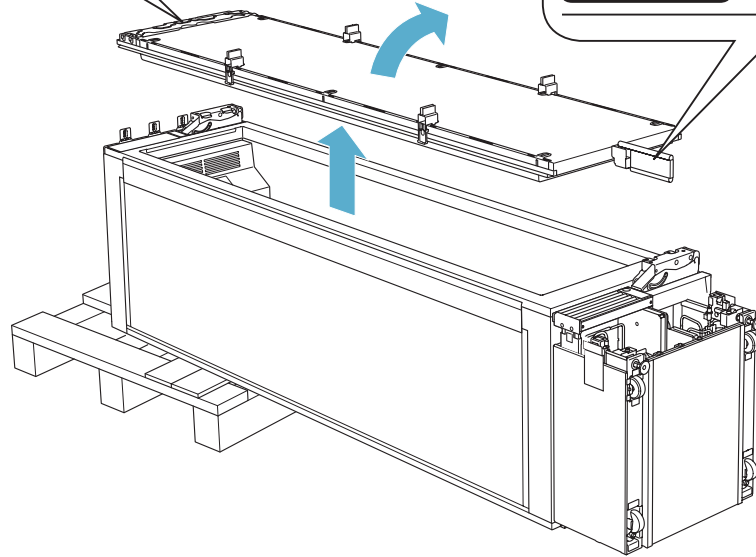
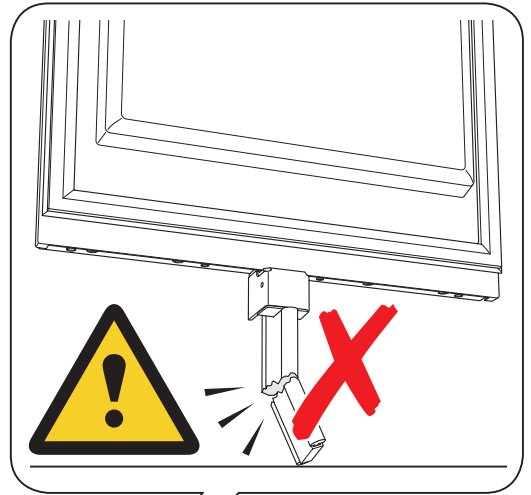
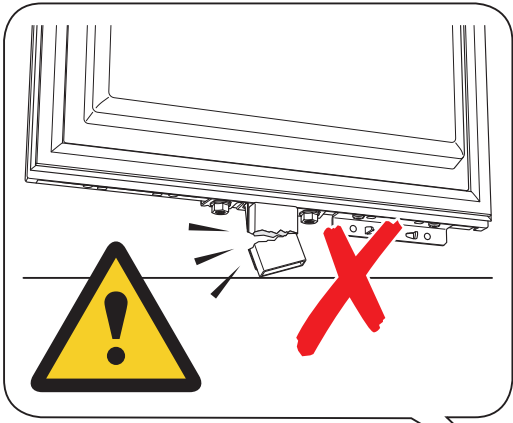

(C) (D)

(B) (D)

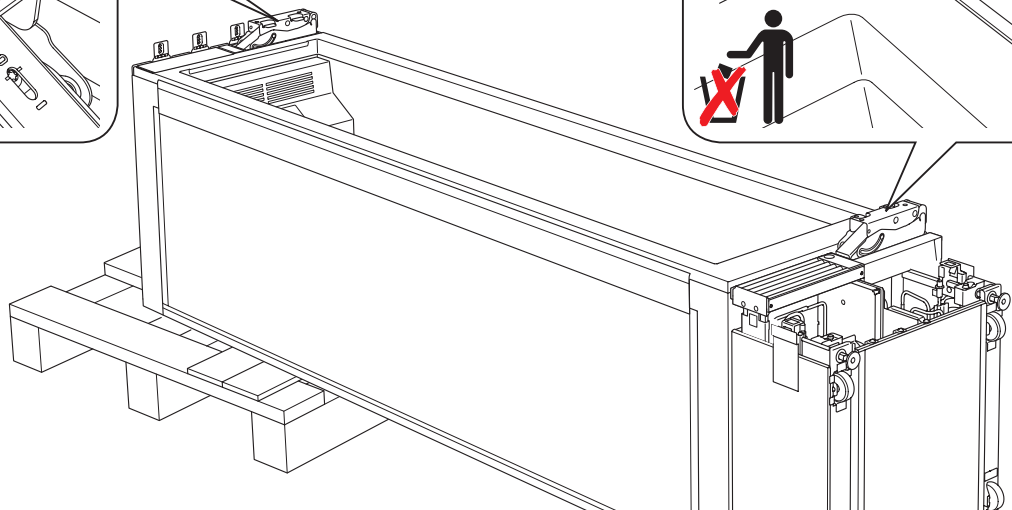
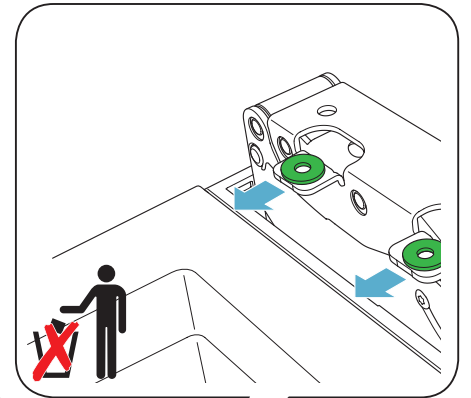
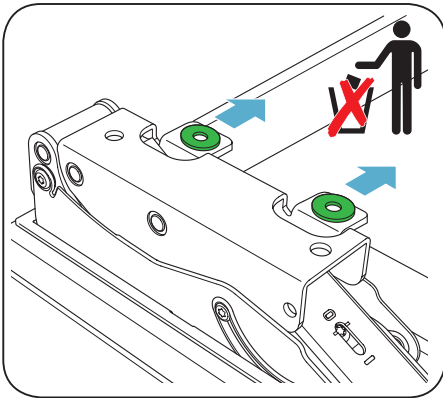

A
B
C
D

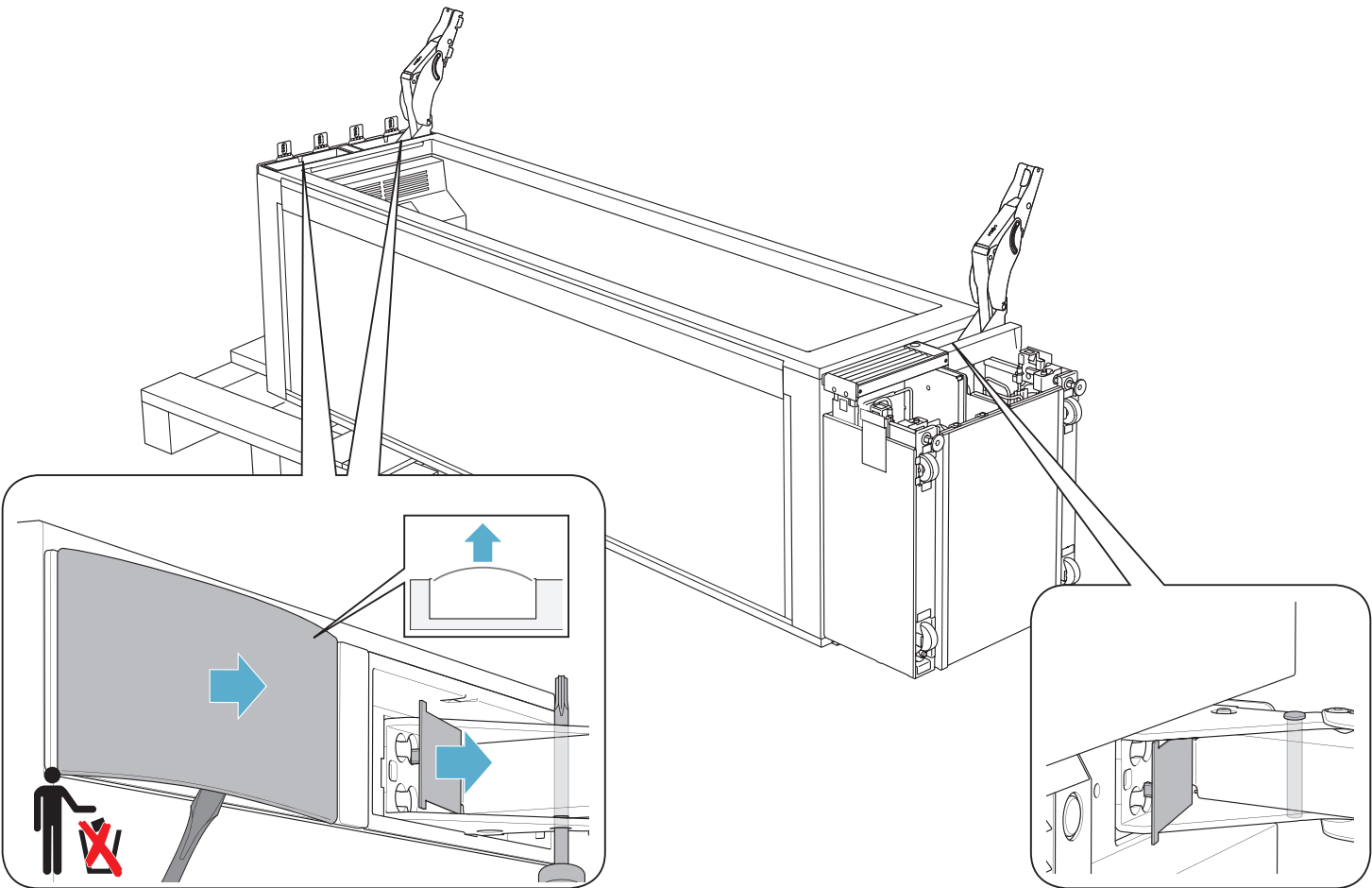
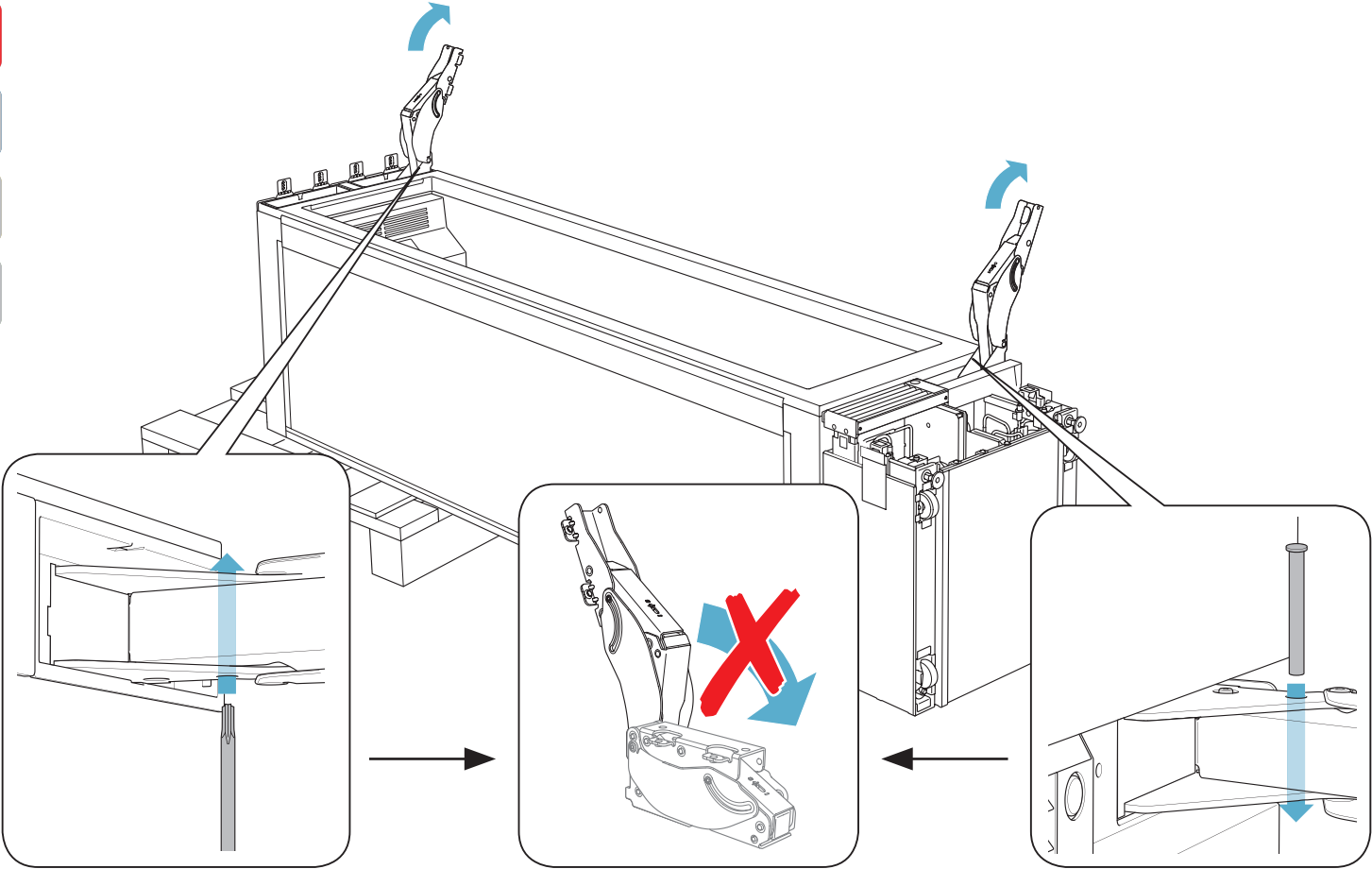

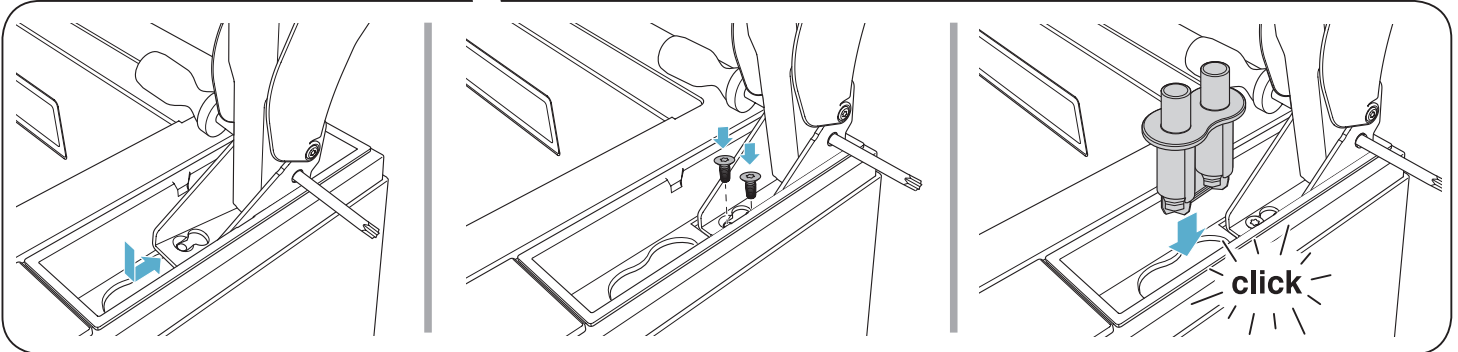
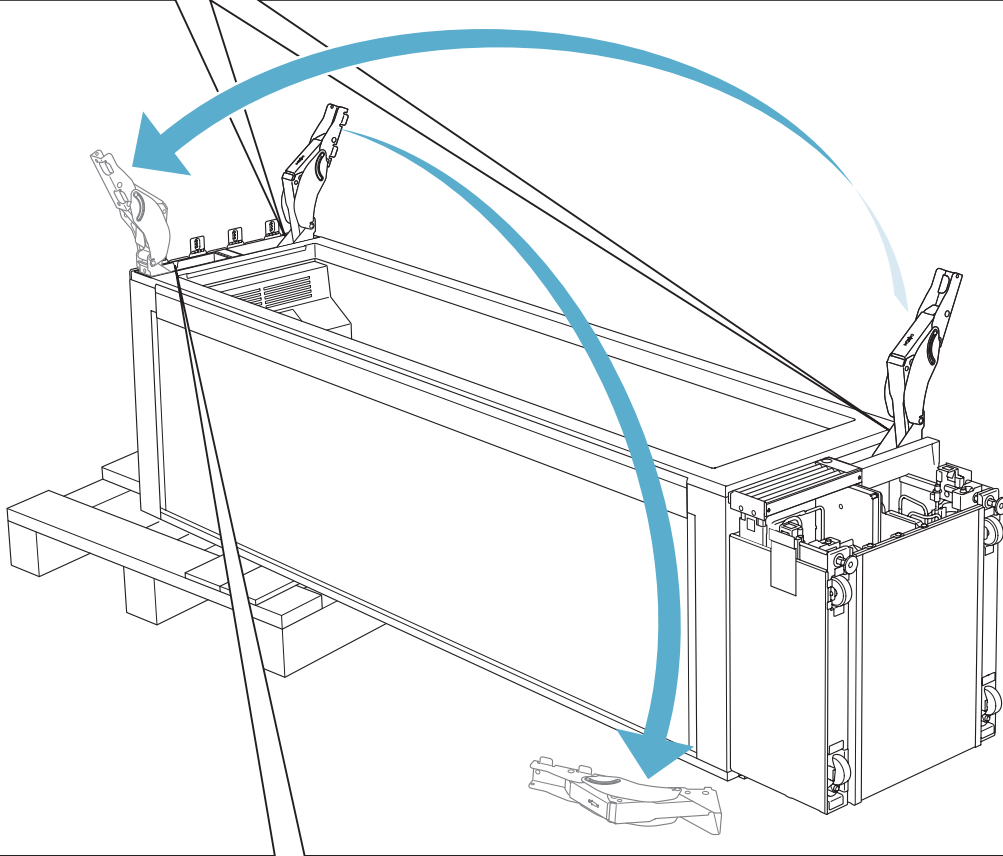
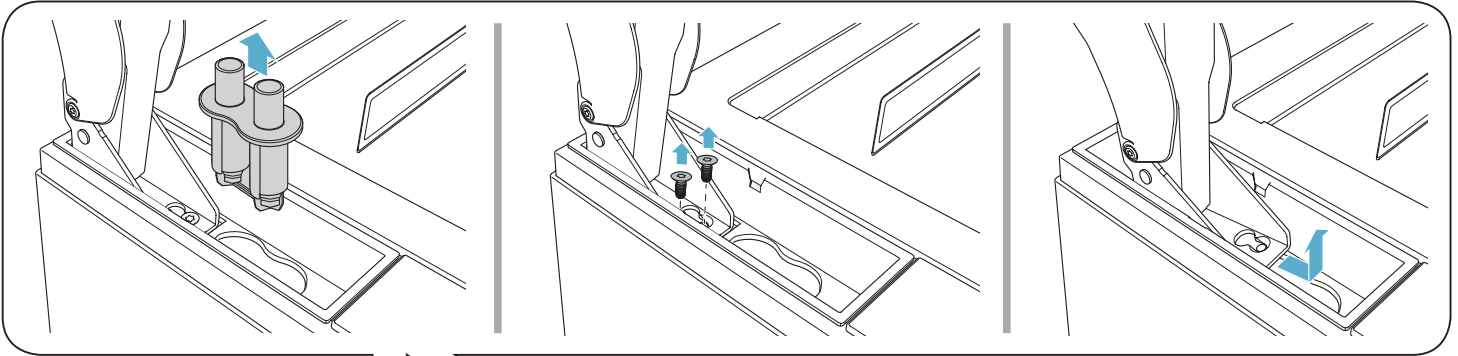
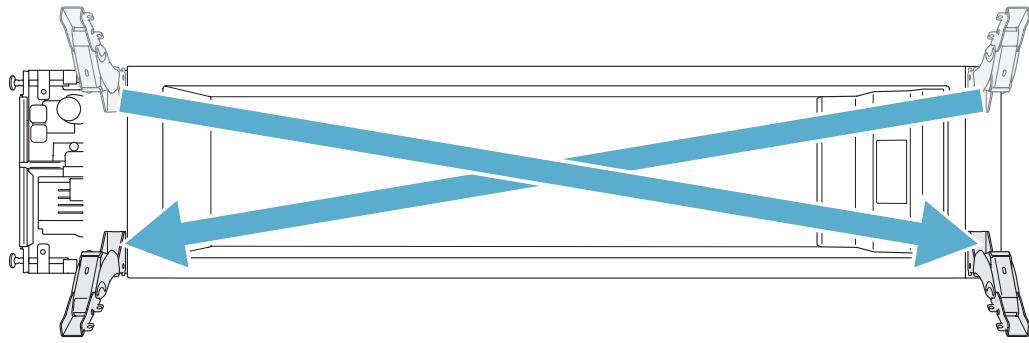

- A
- B
- C
- D

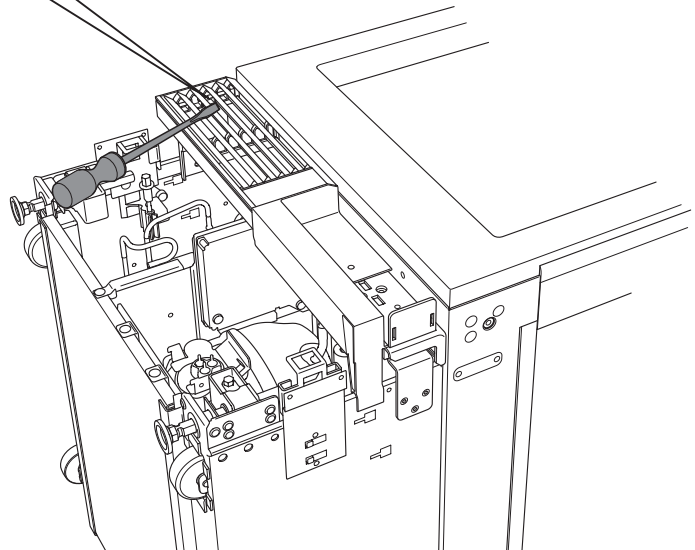
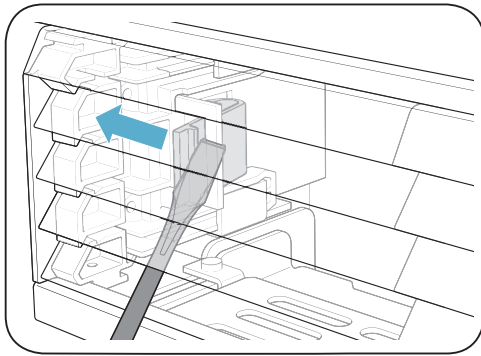
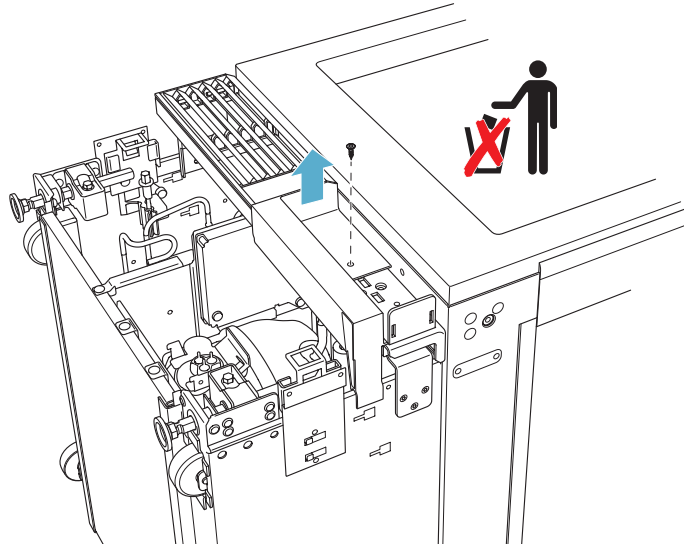
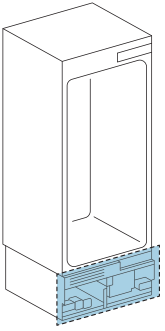

A

B

C

D

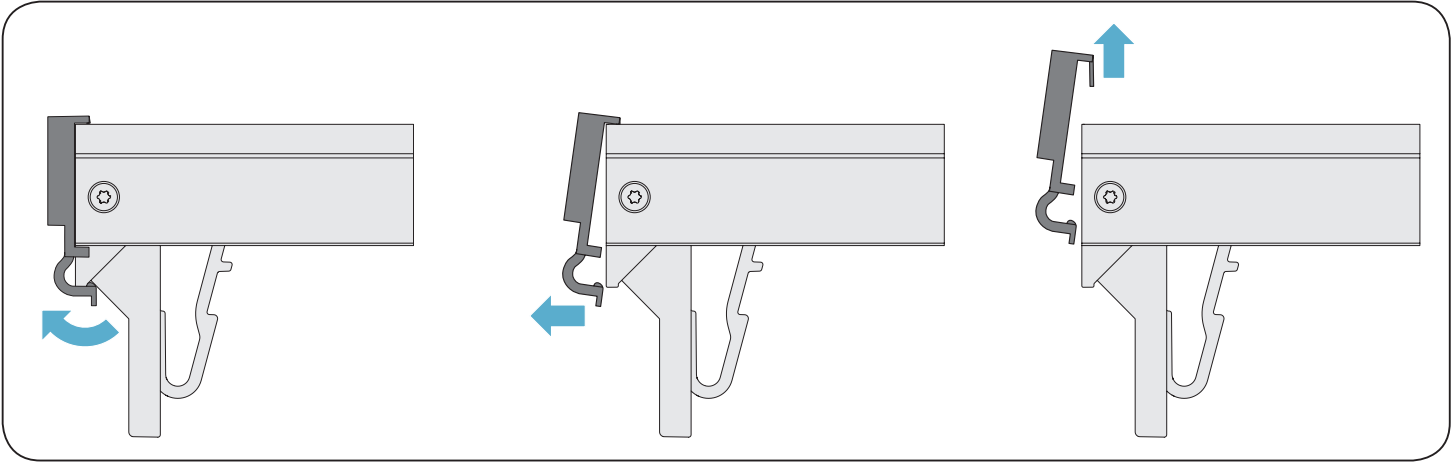
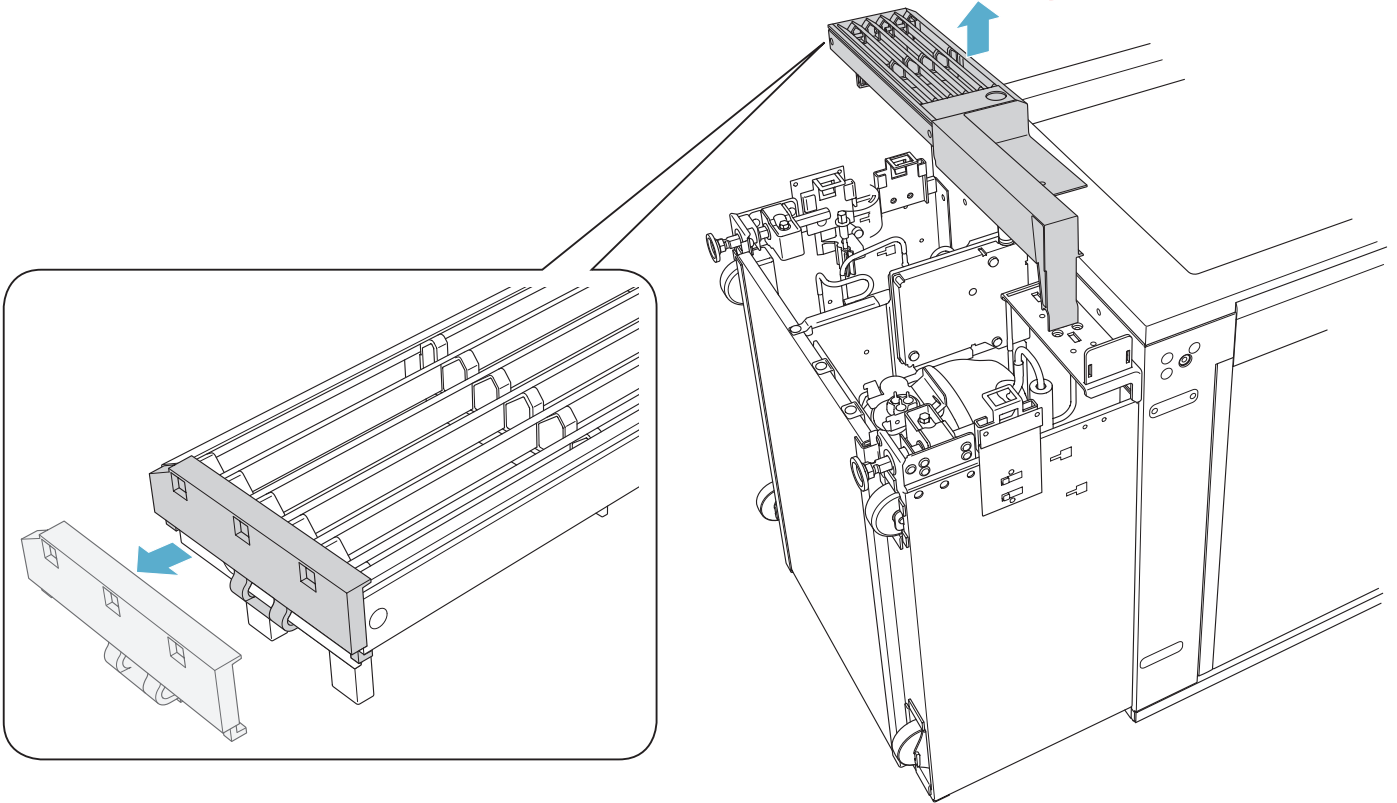

A

B

C

D

28

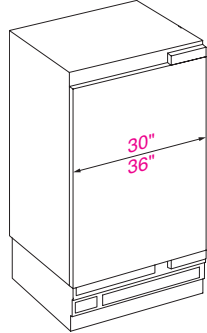
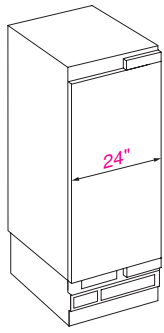

→31

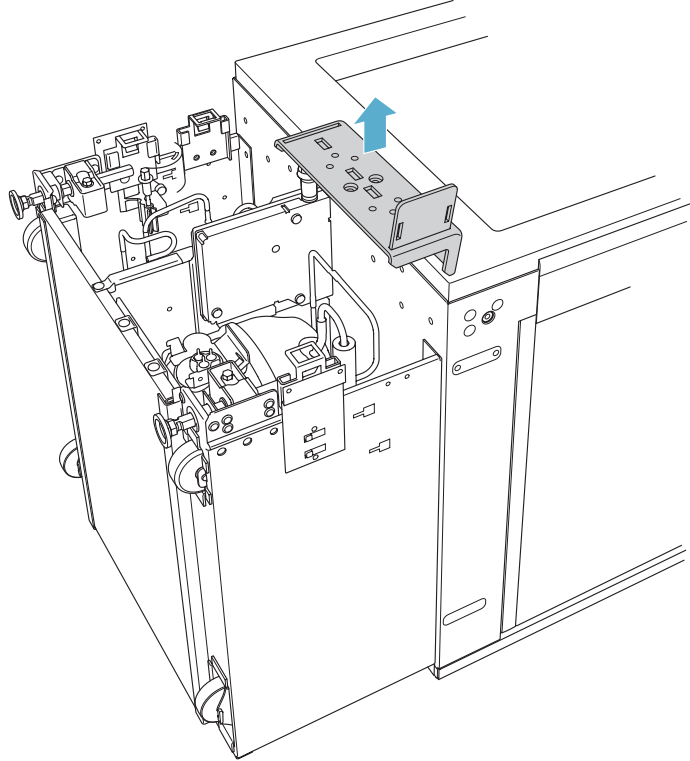
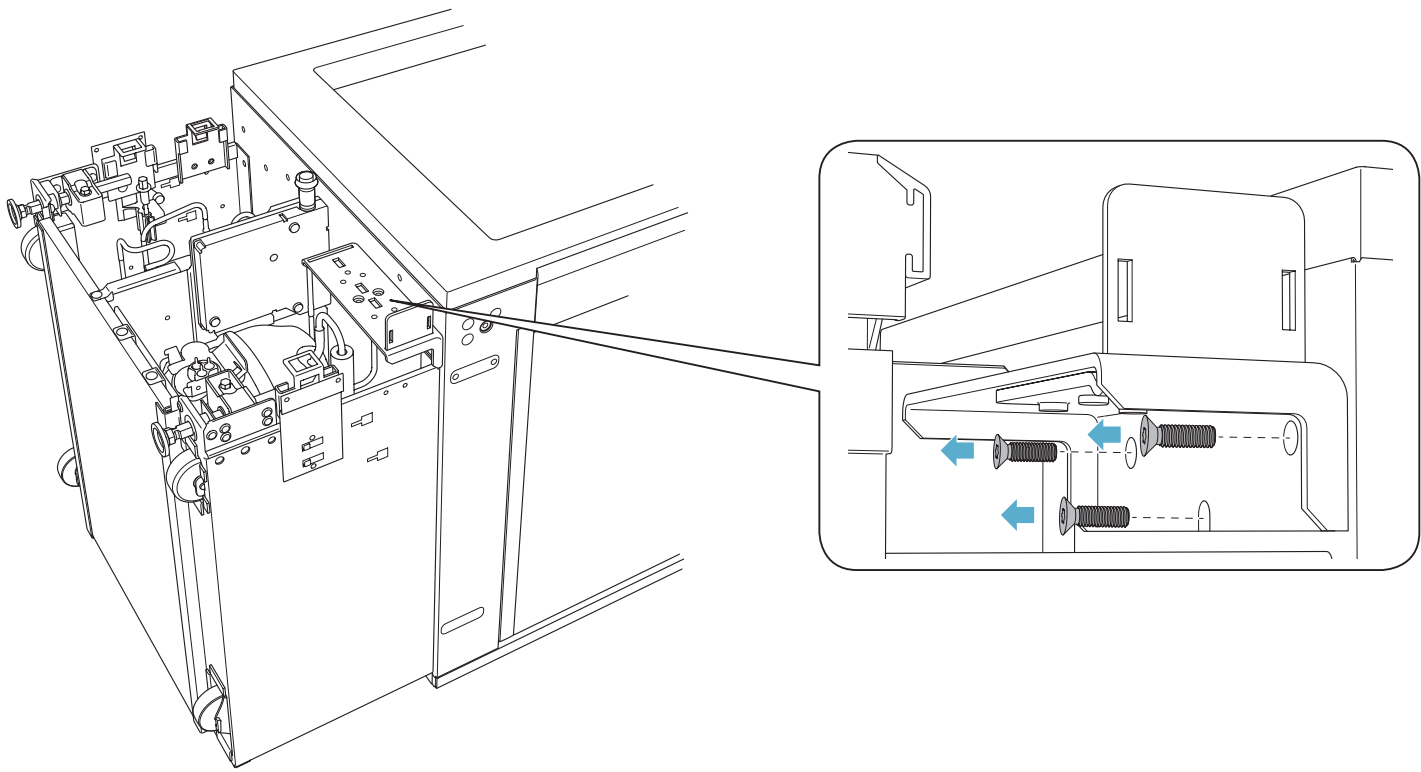

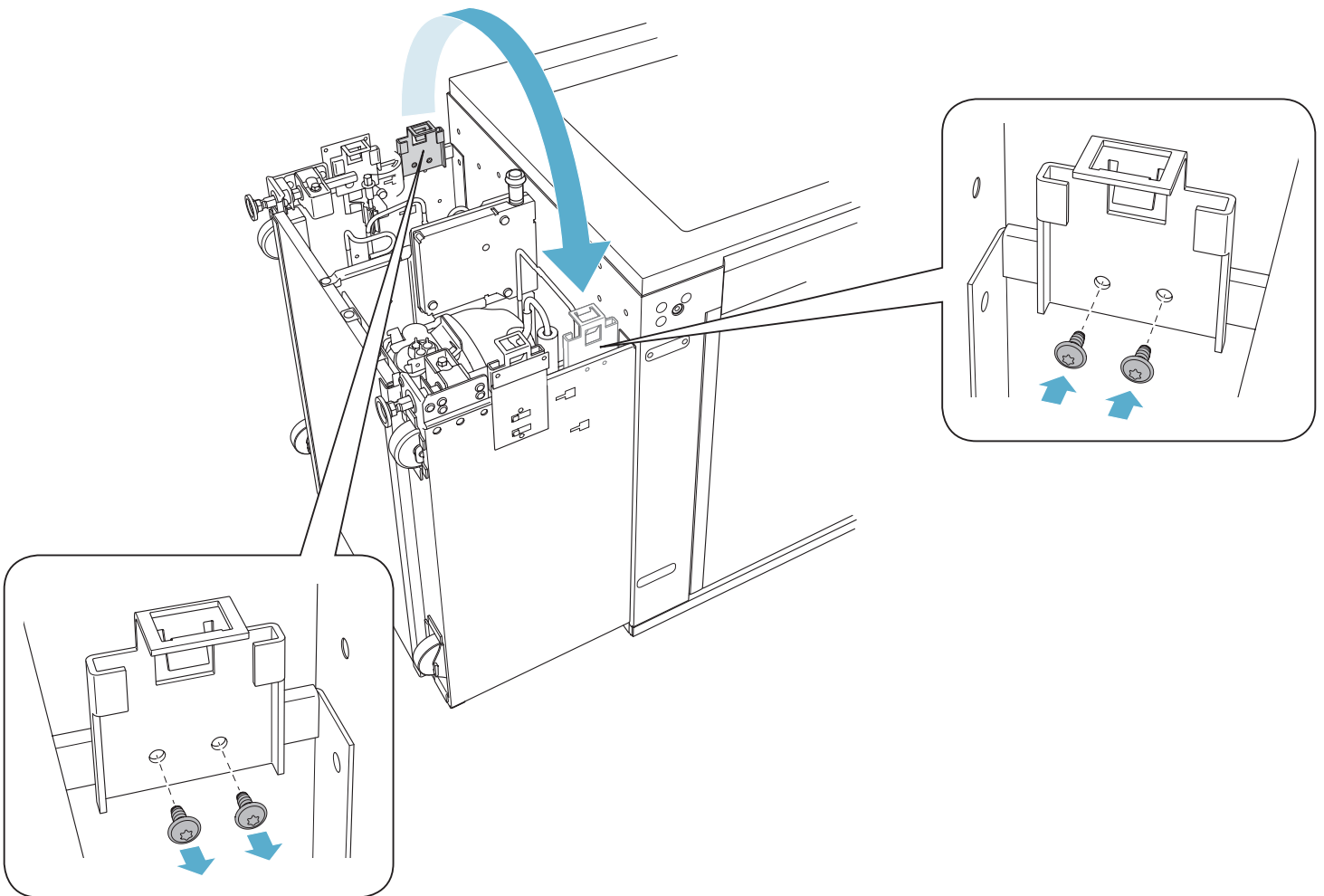
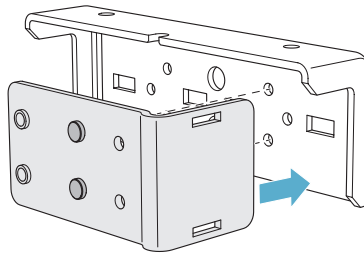
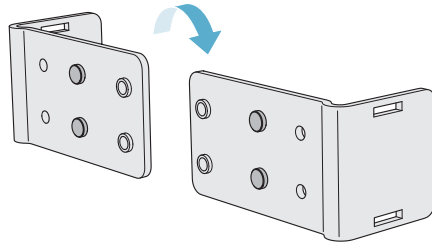
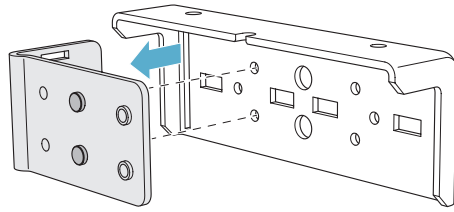

A

B

C

D

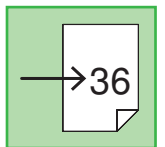
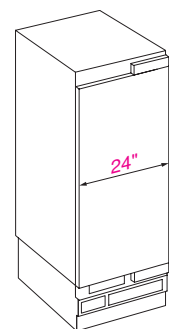
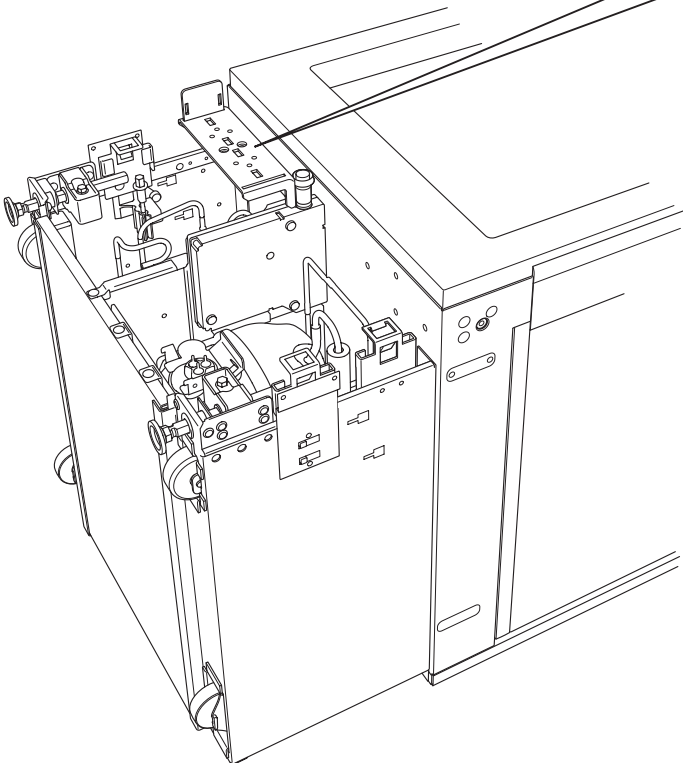
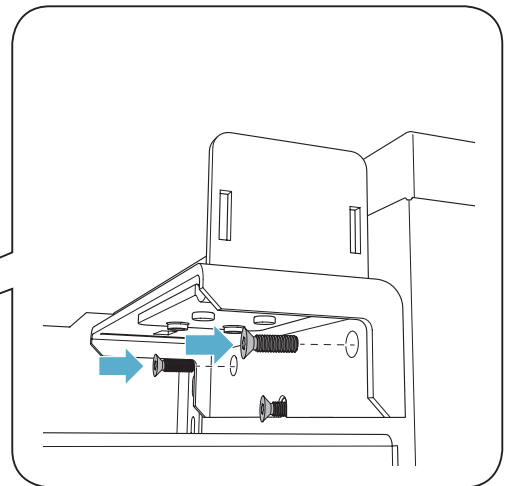
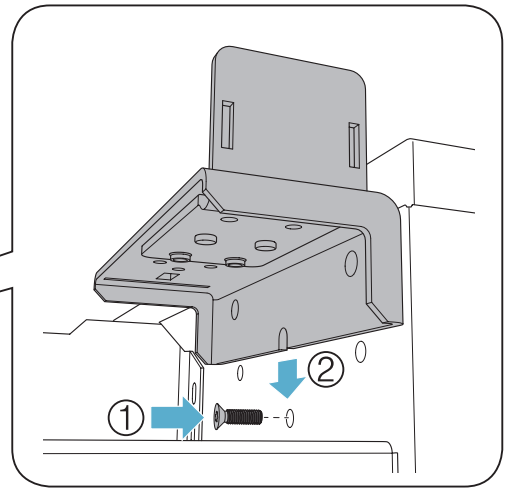
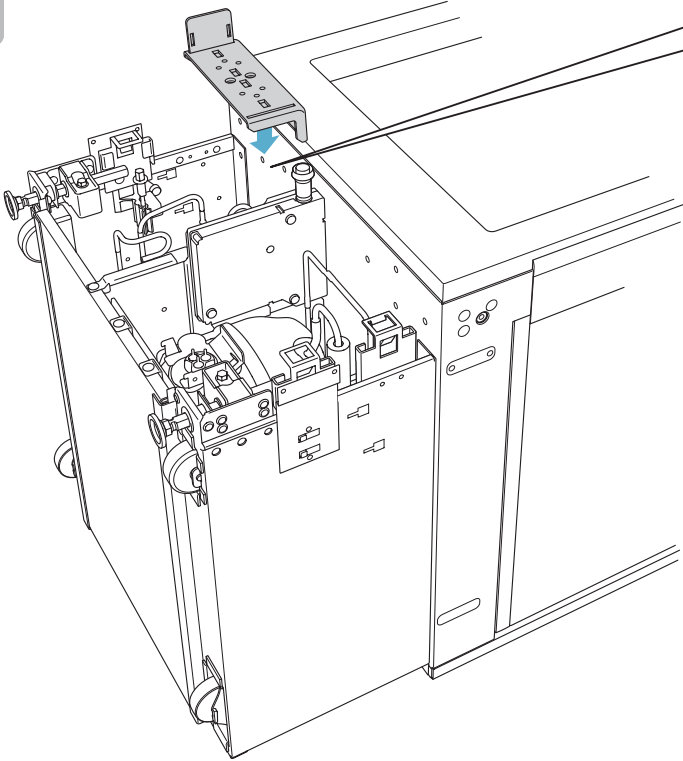

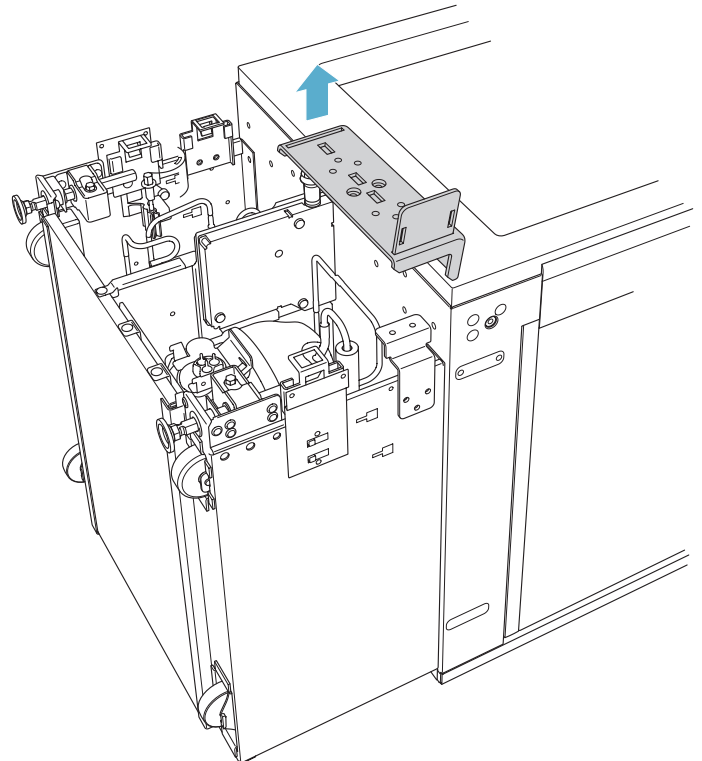
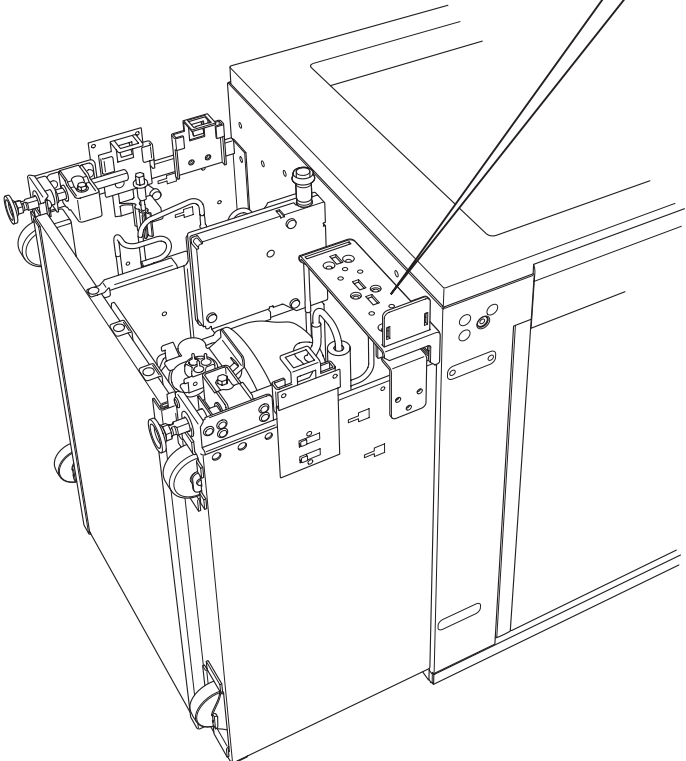
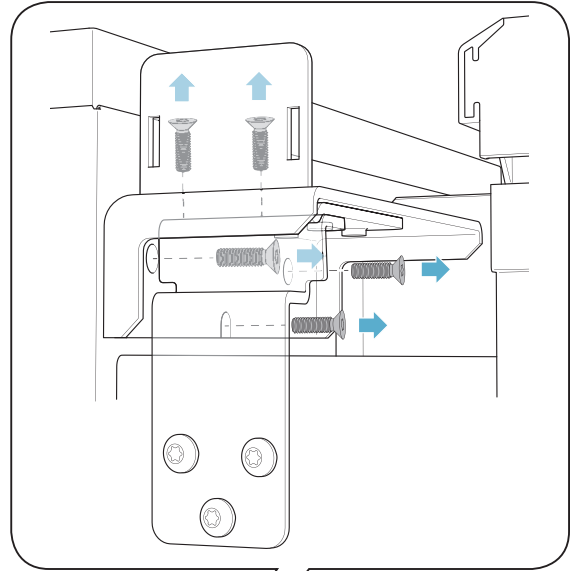
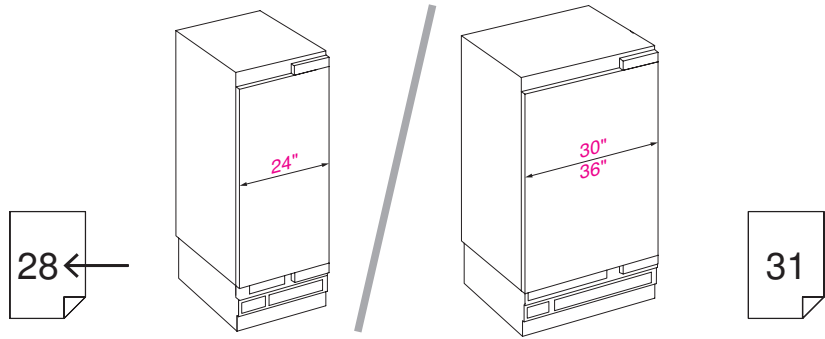

A

B

C

D

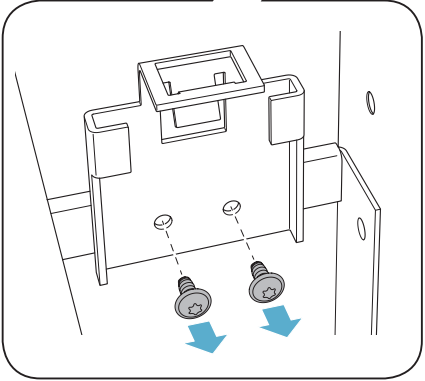
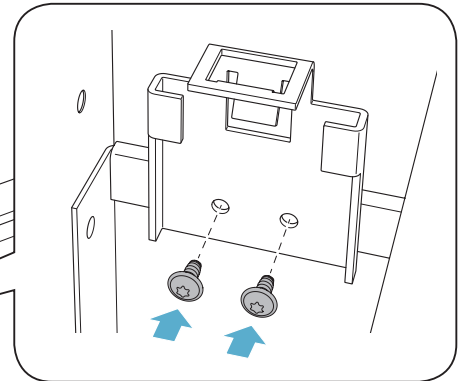
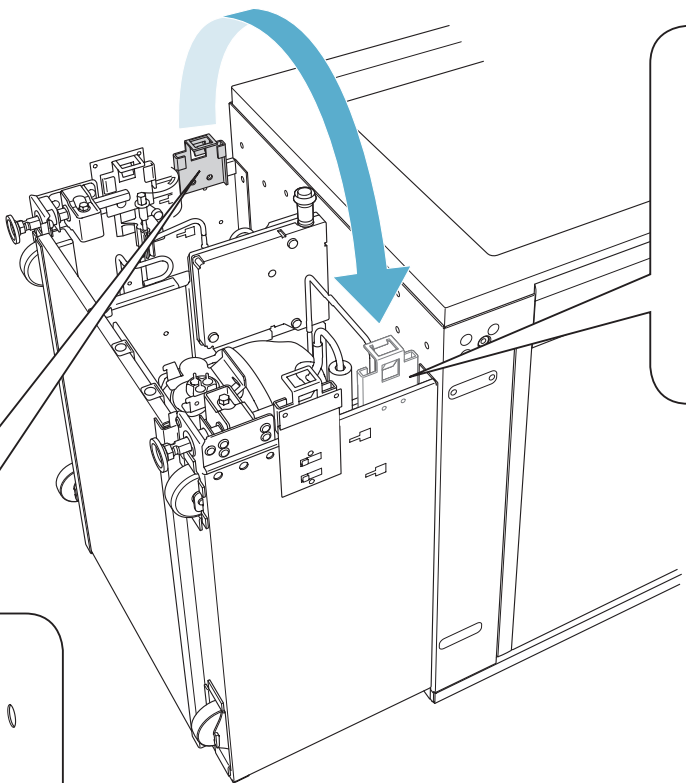
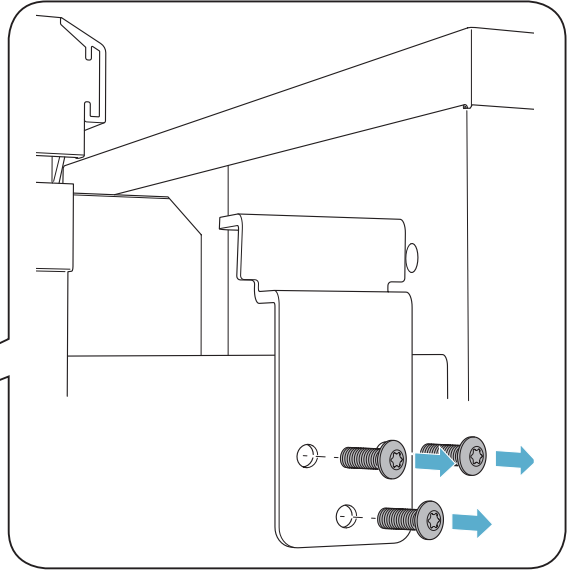
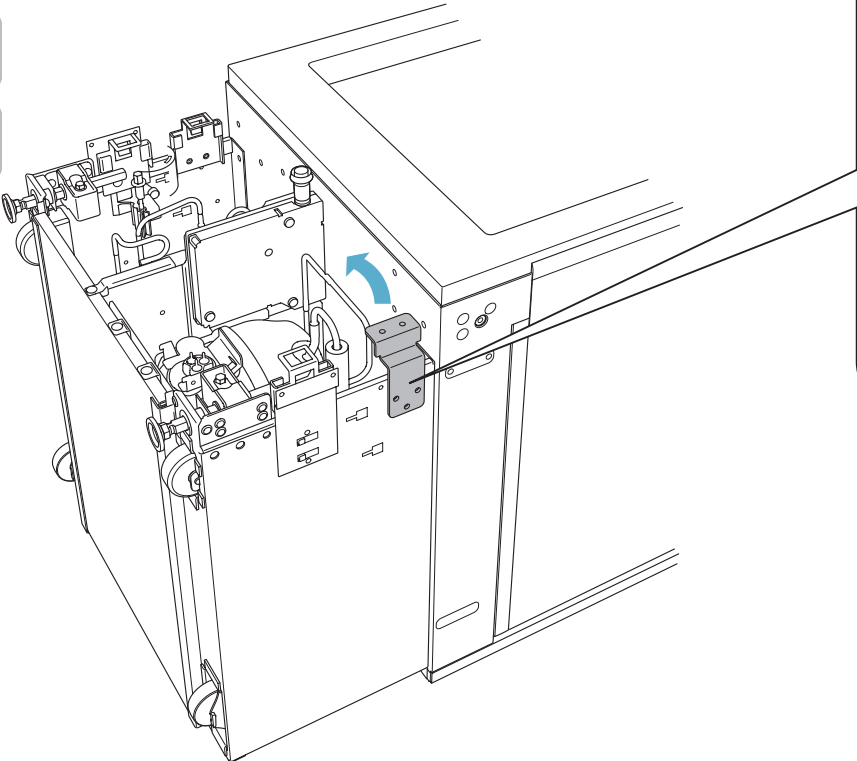

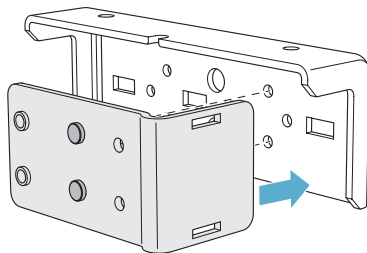
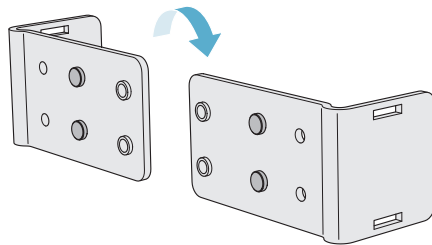
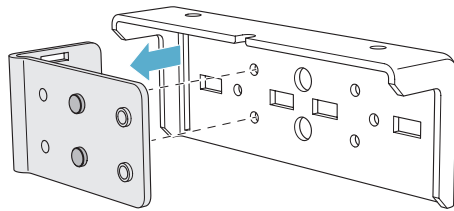
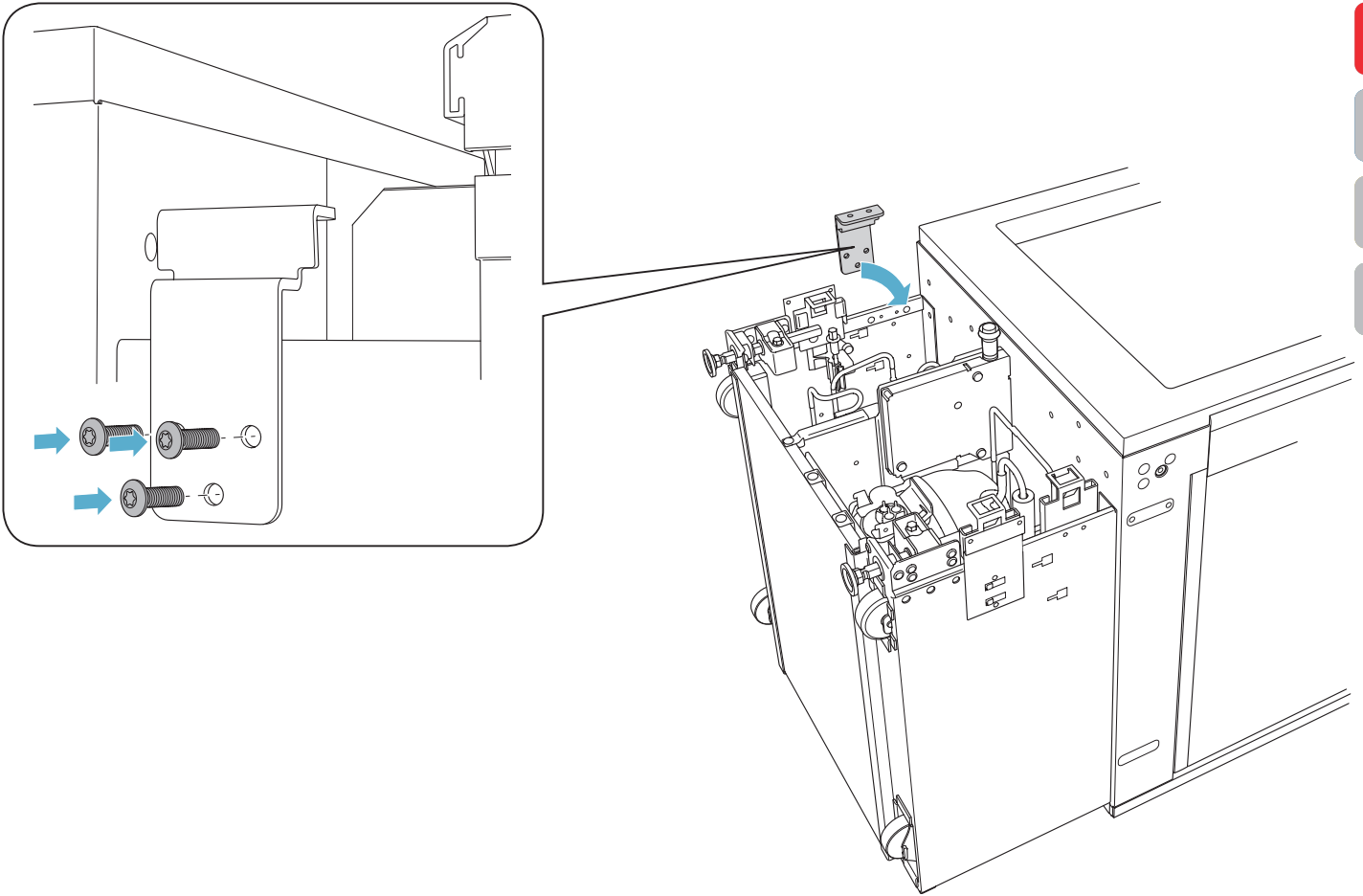

A

B

C

D

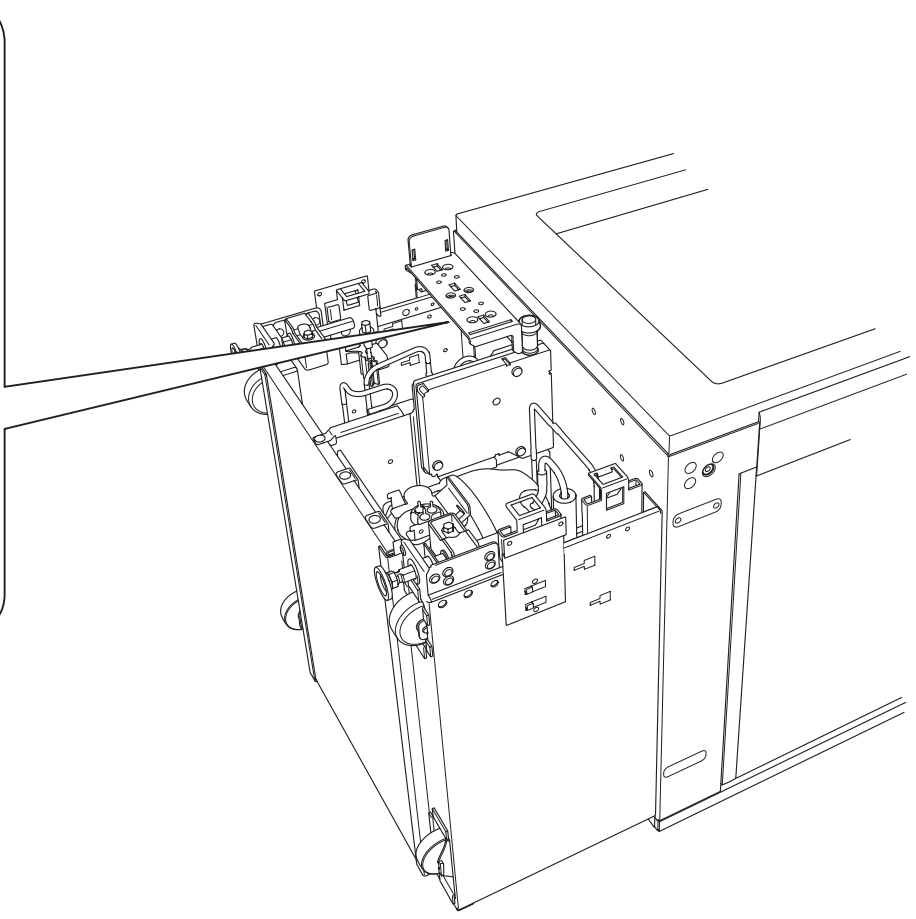
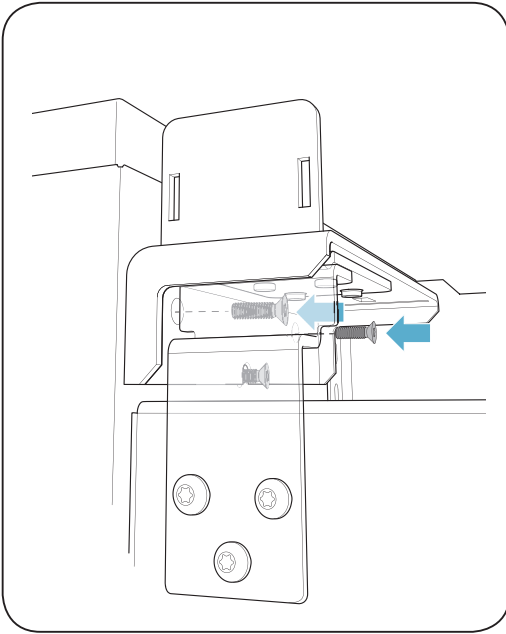
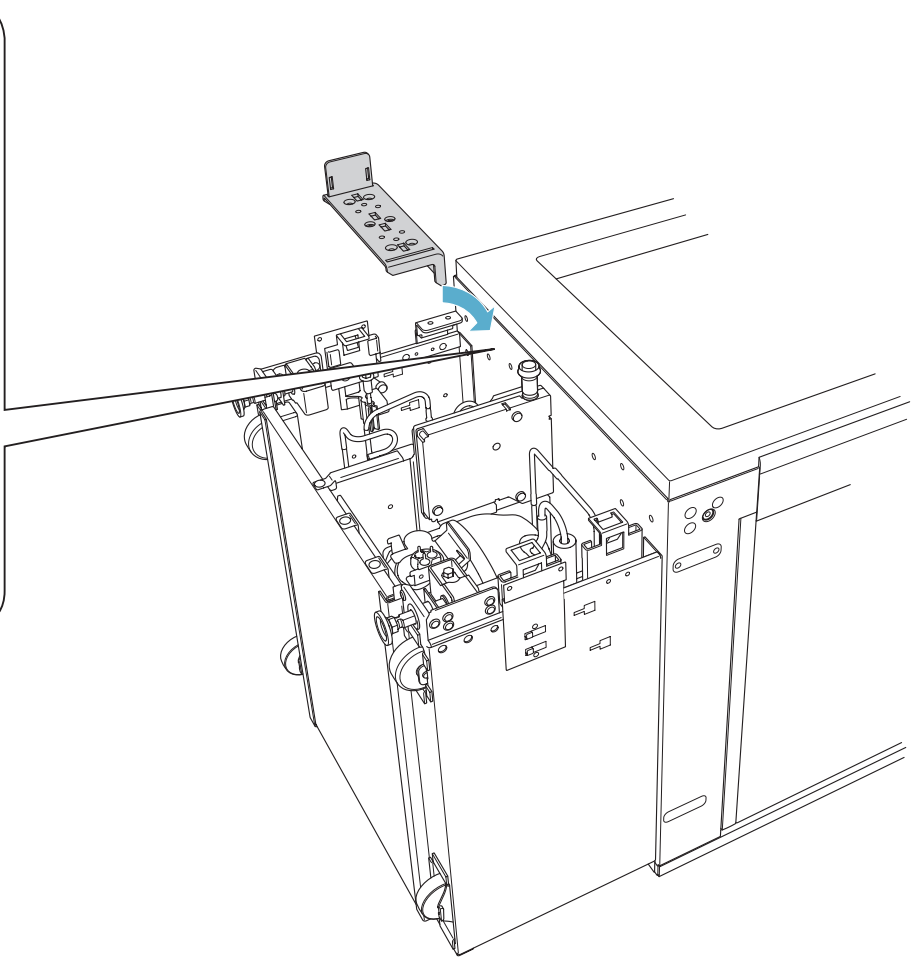
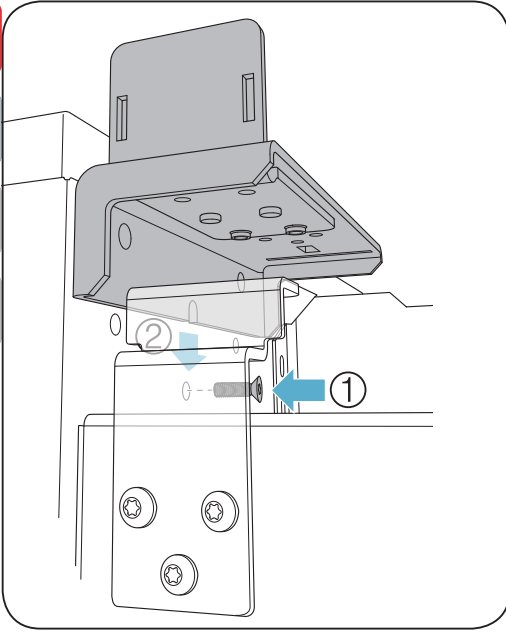

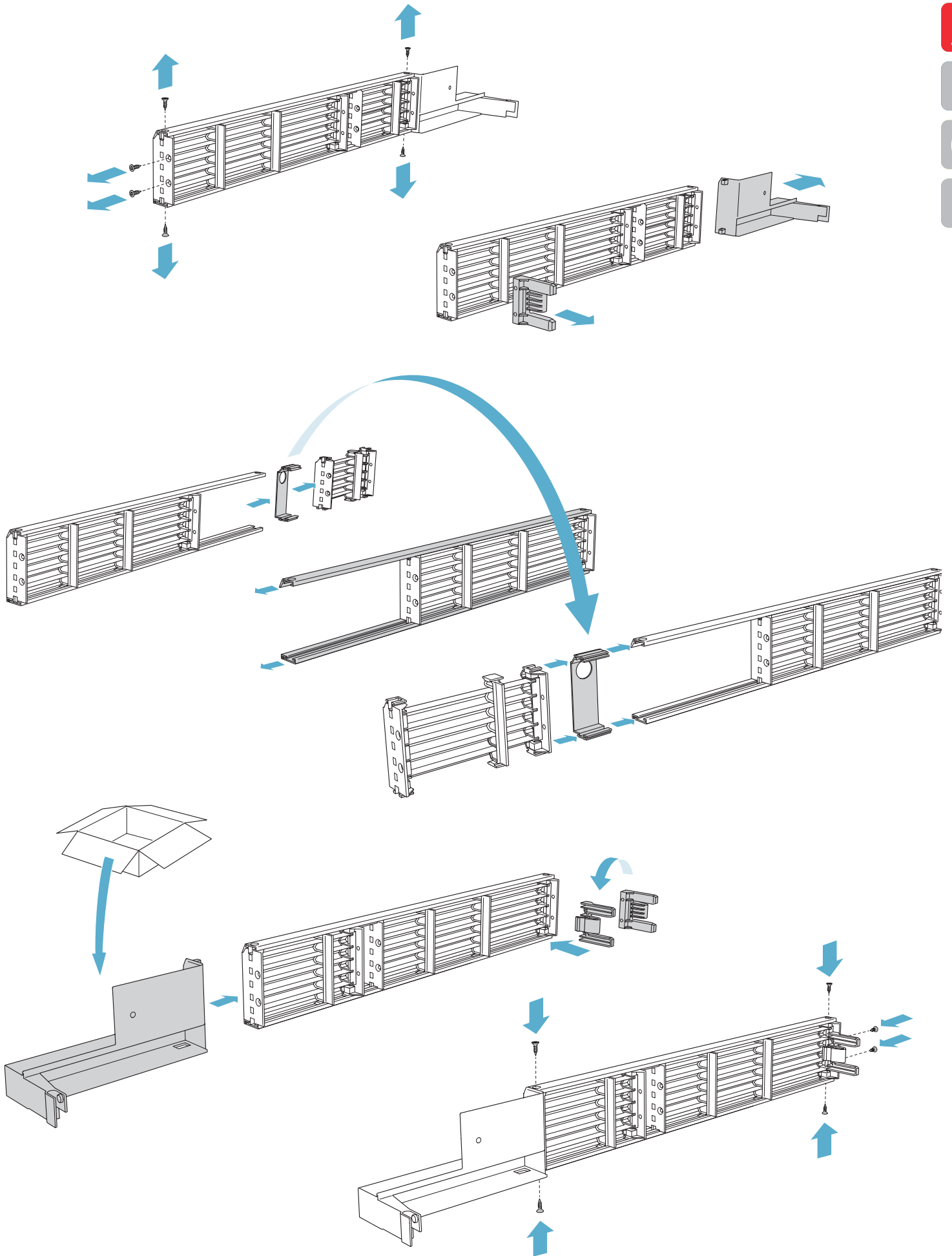

A

B

C

D

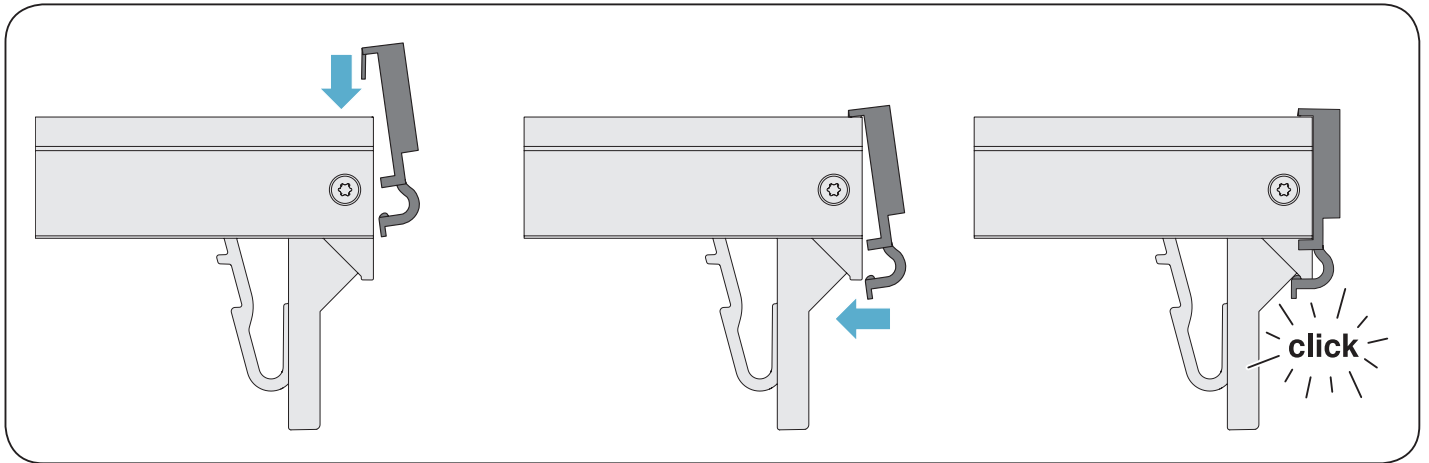
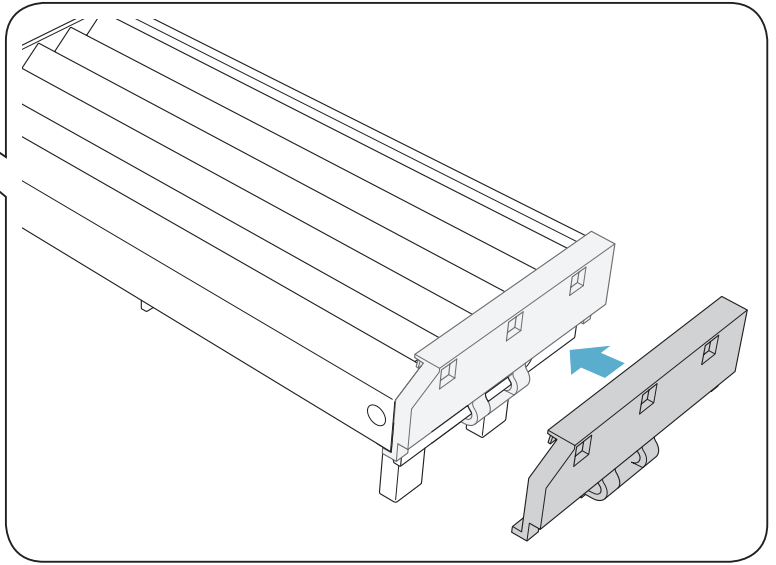
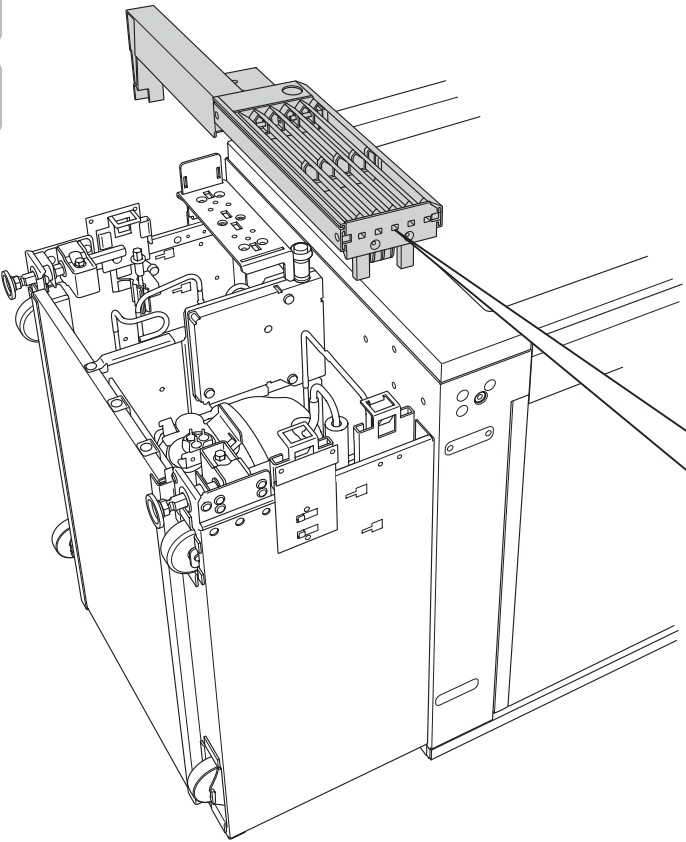
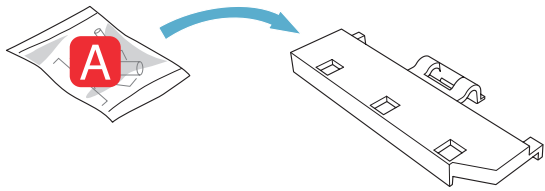

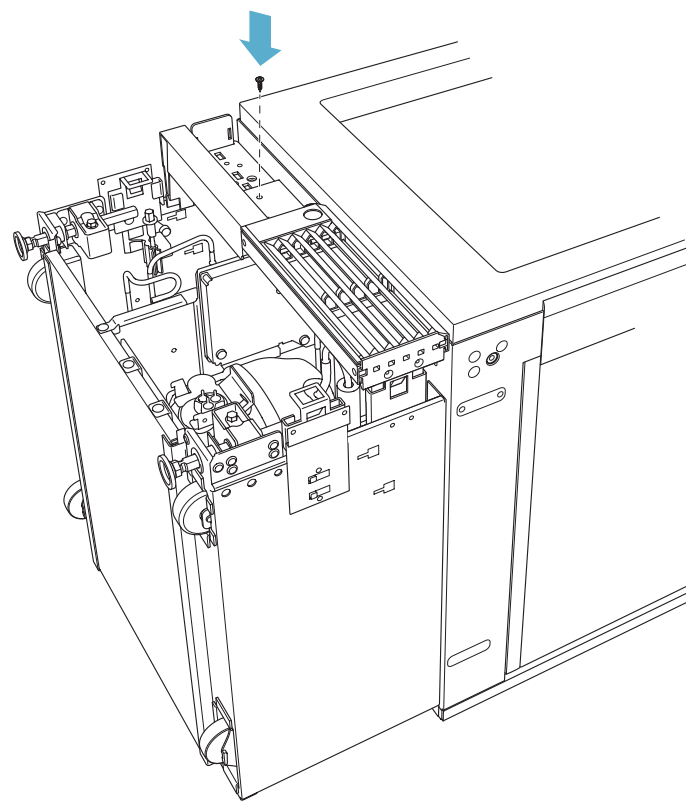
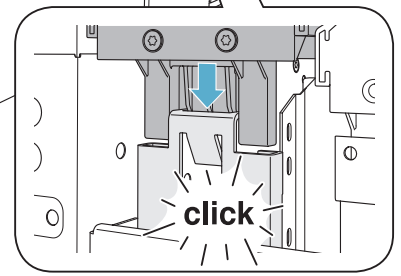
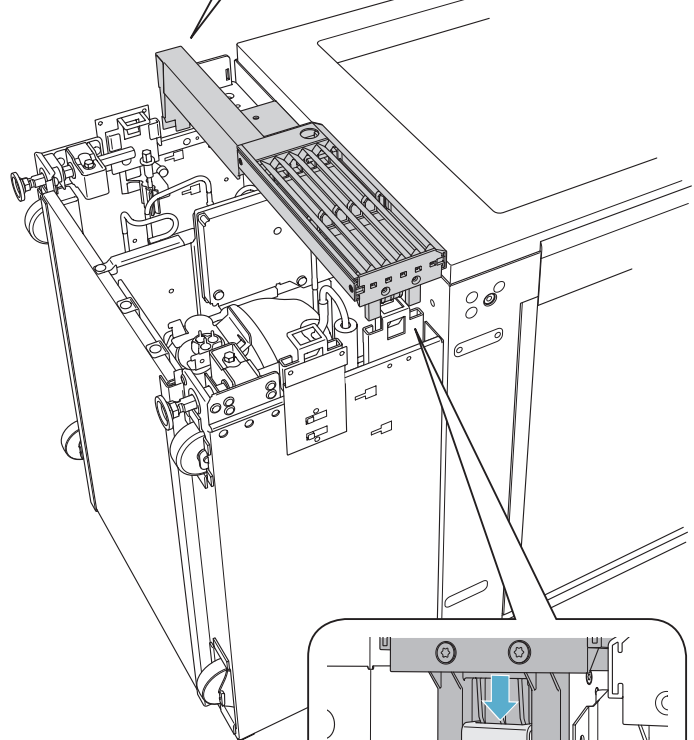
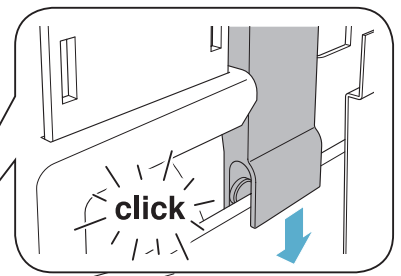
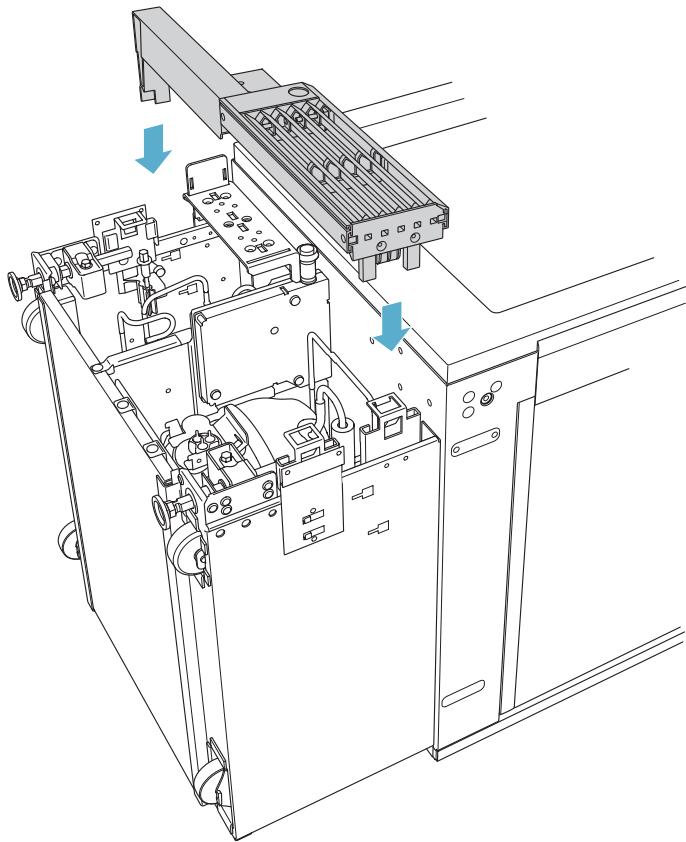

- A
- B
- C
- D

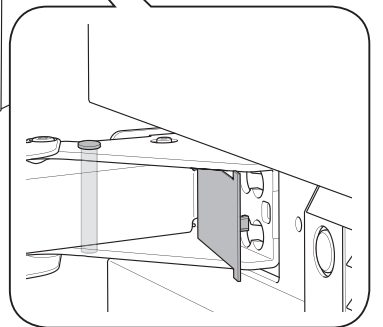
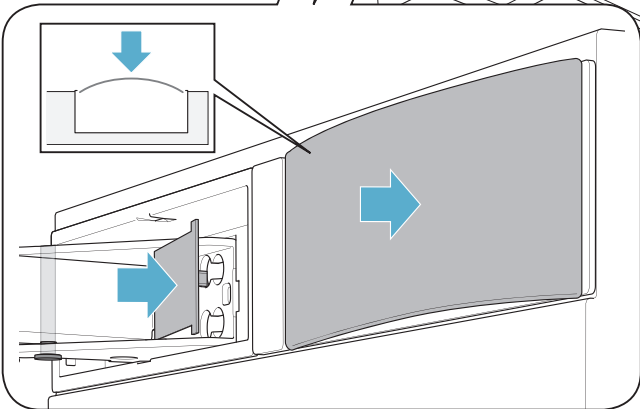
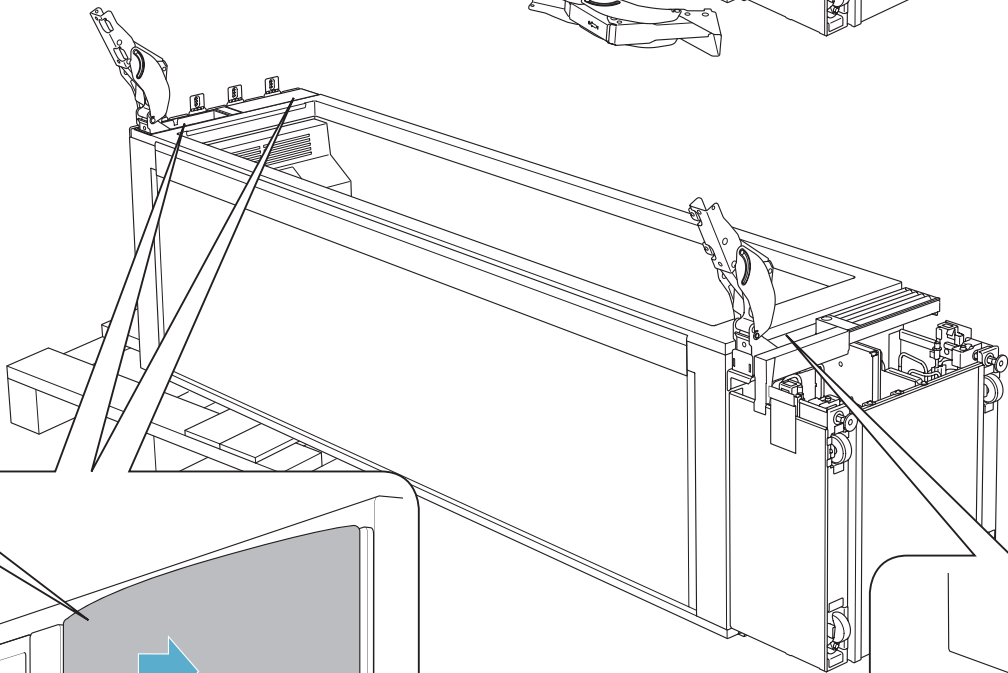
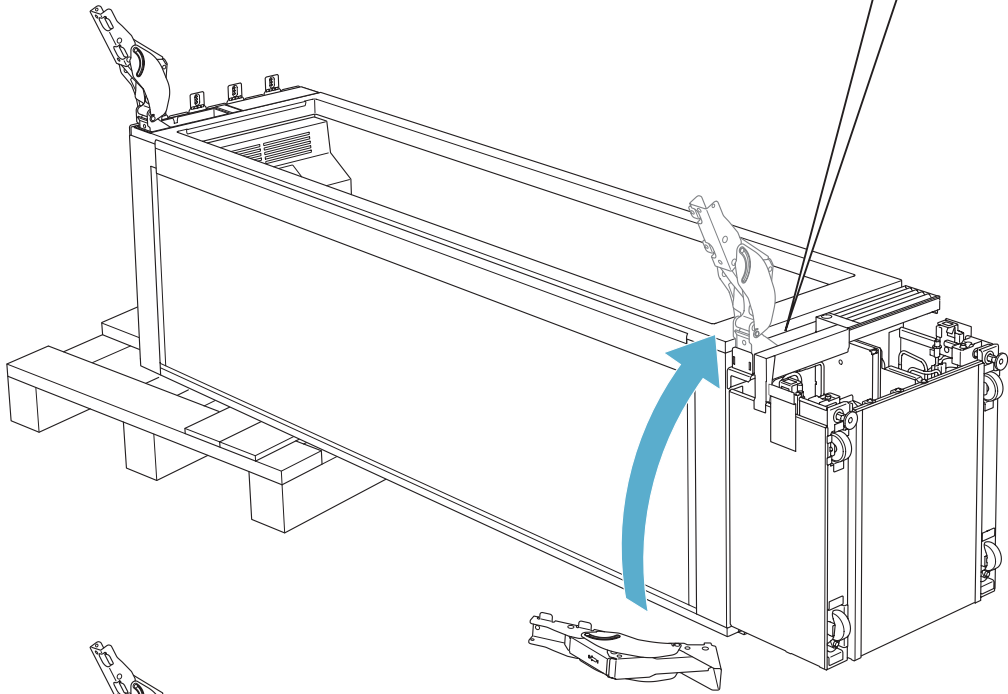
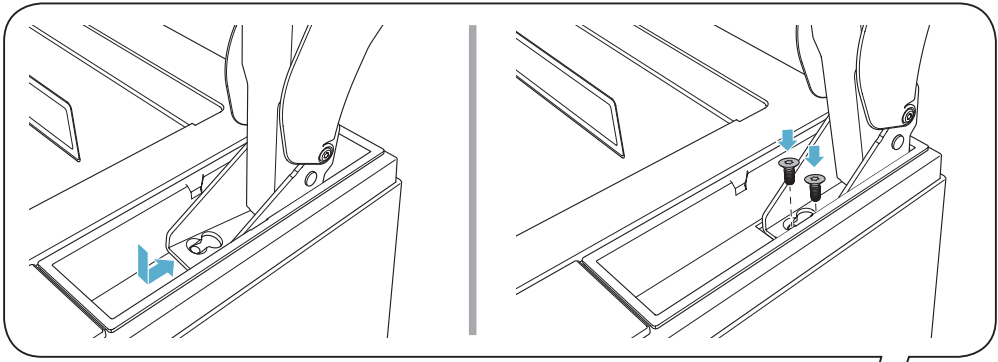

A
B
C
D

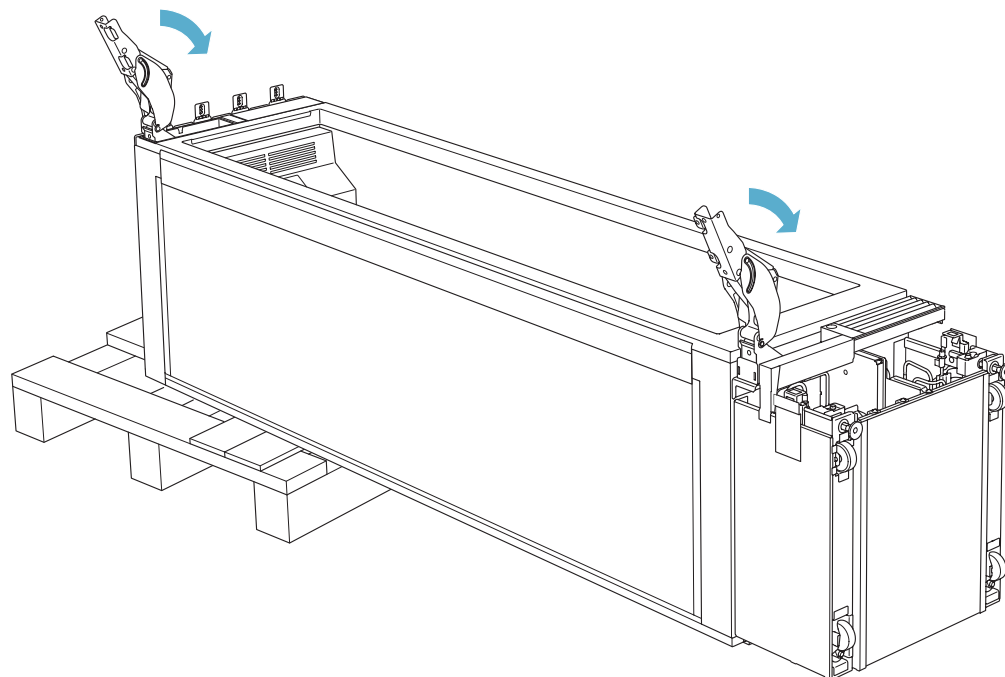
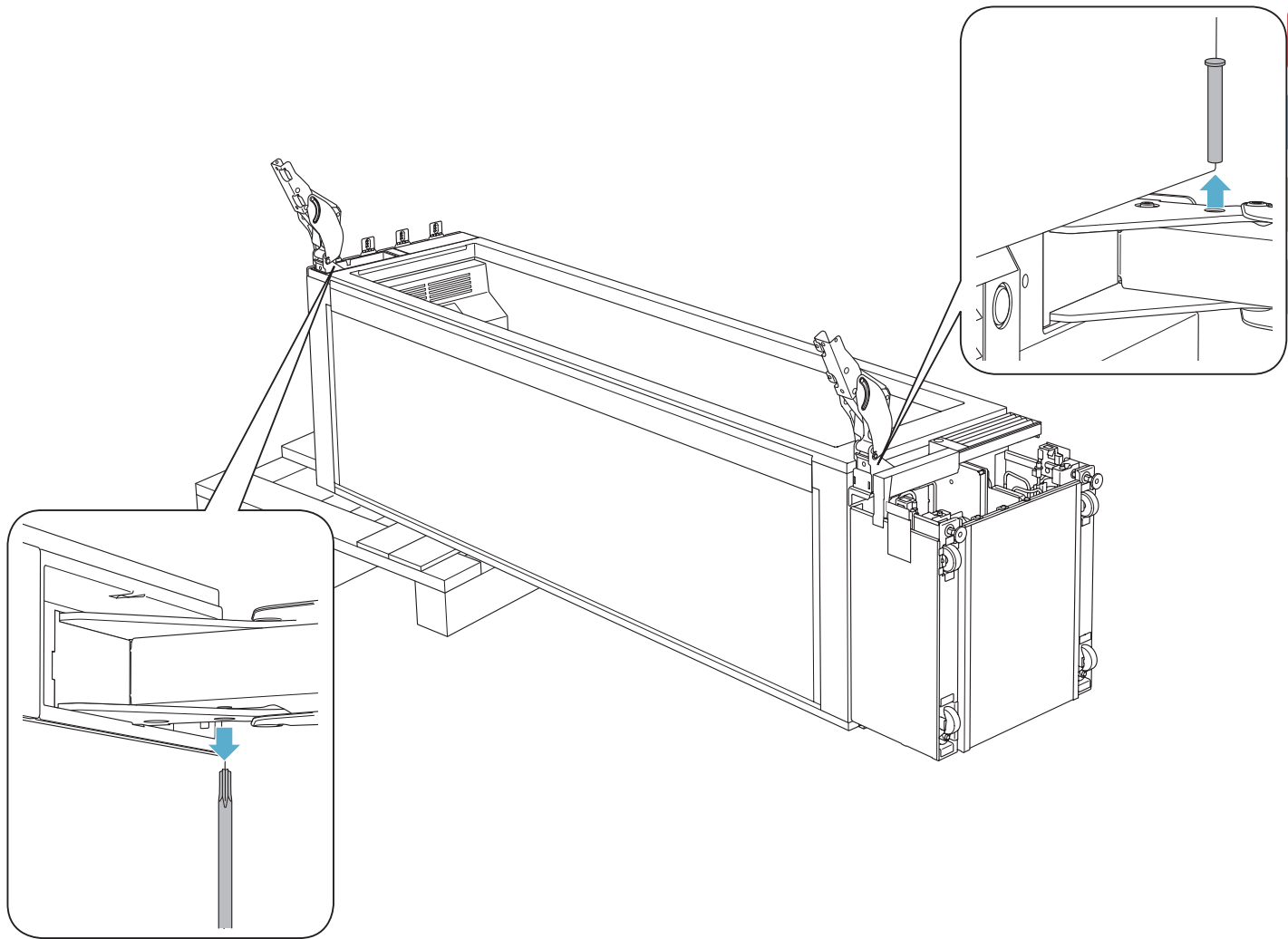

A
B
C
D

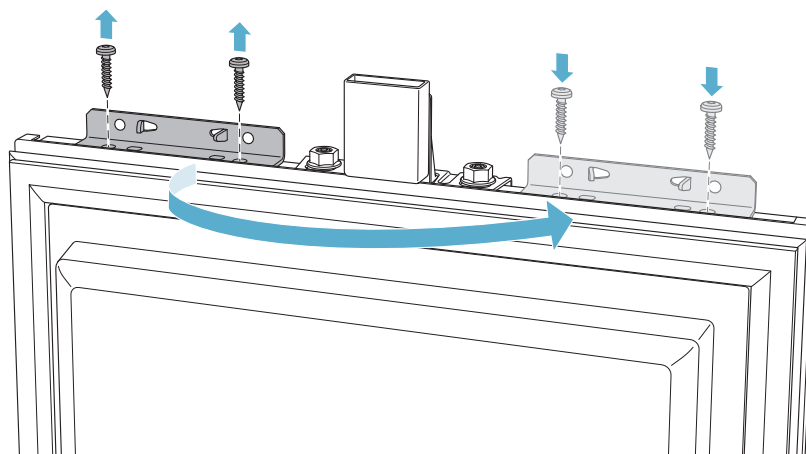
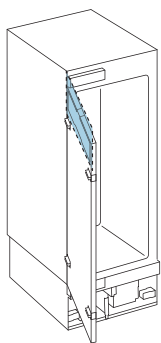
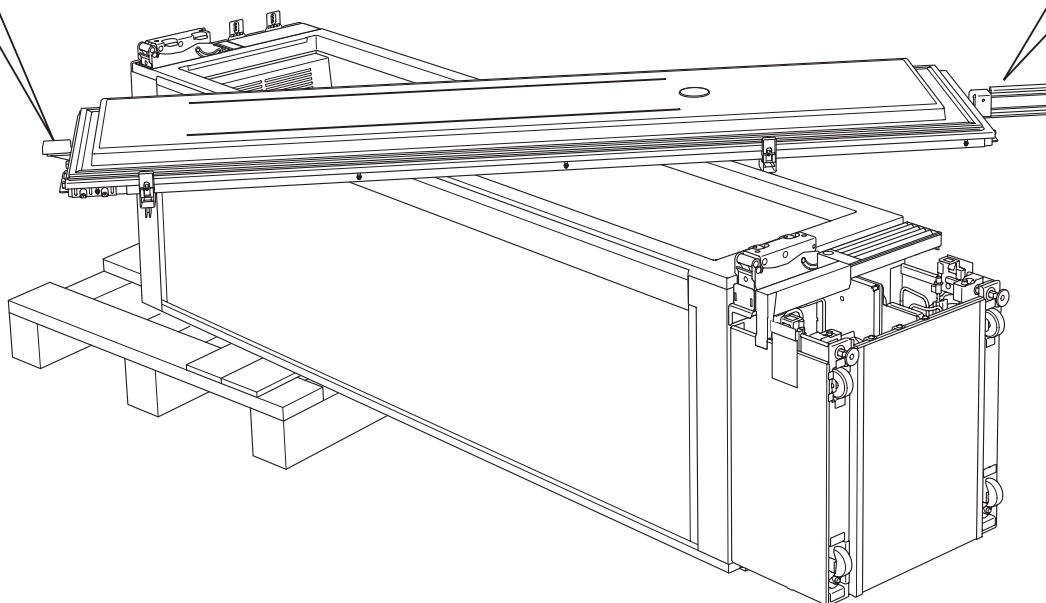
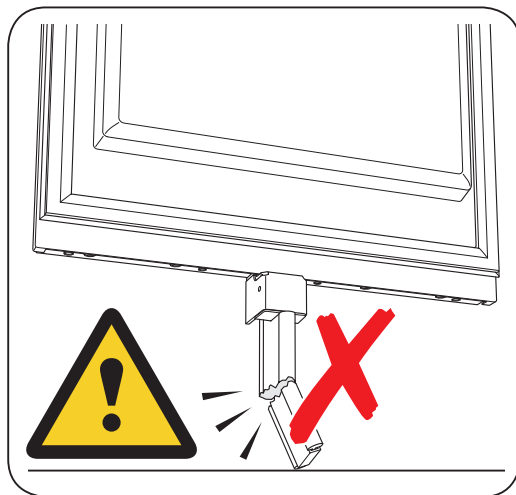
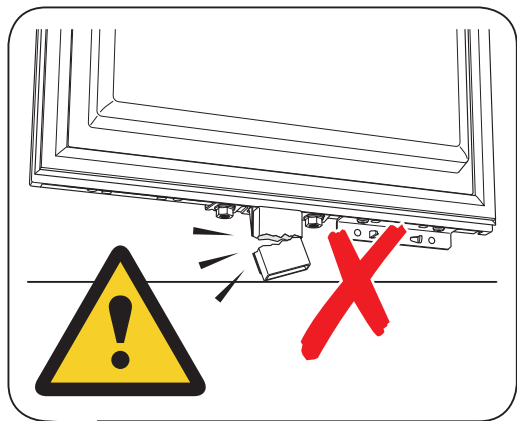

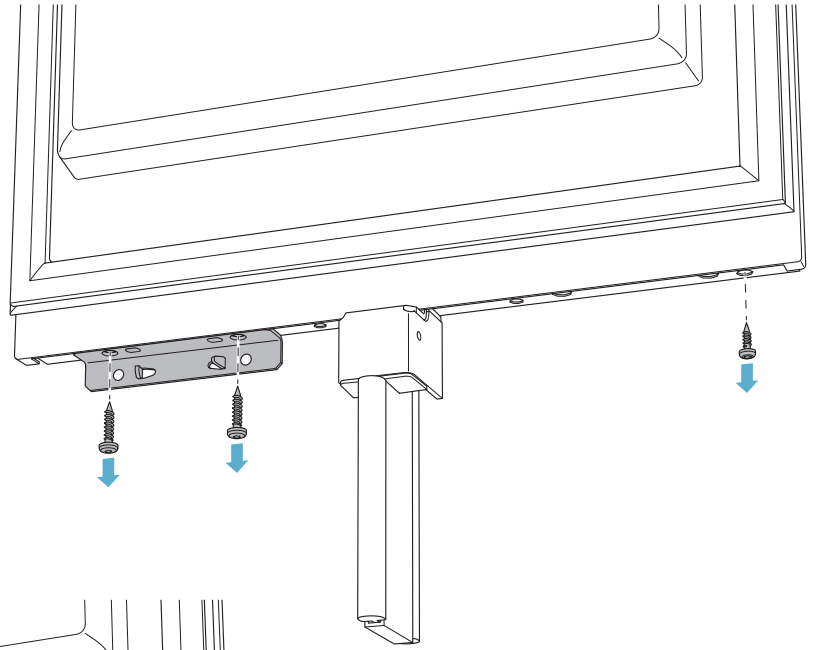
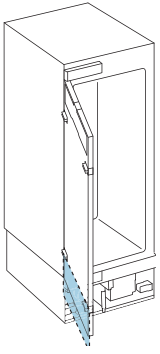

A
B
C
D

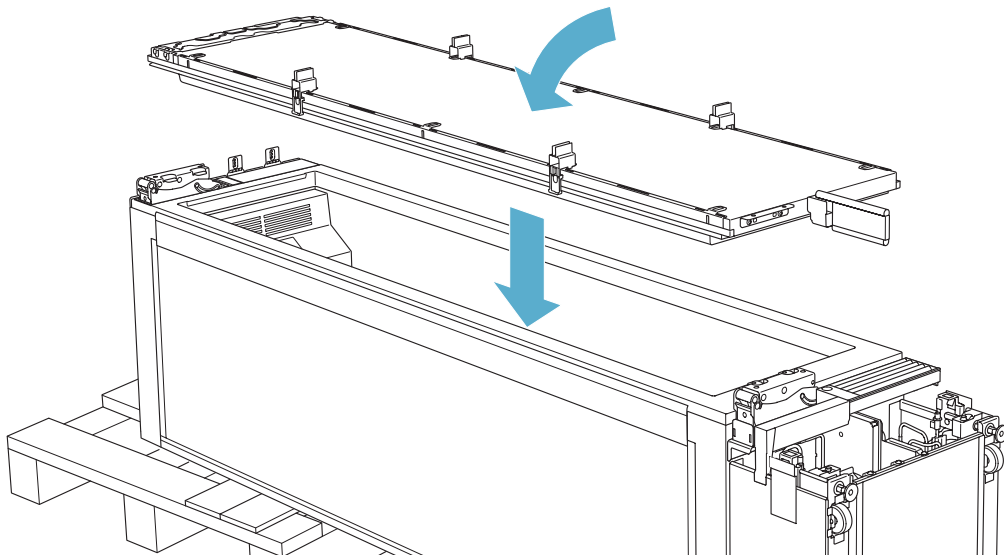
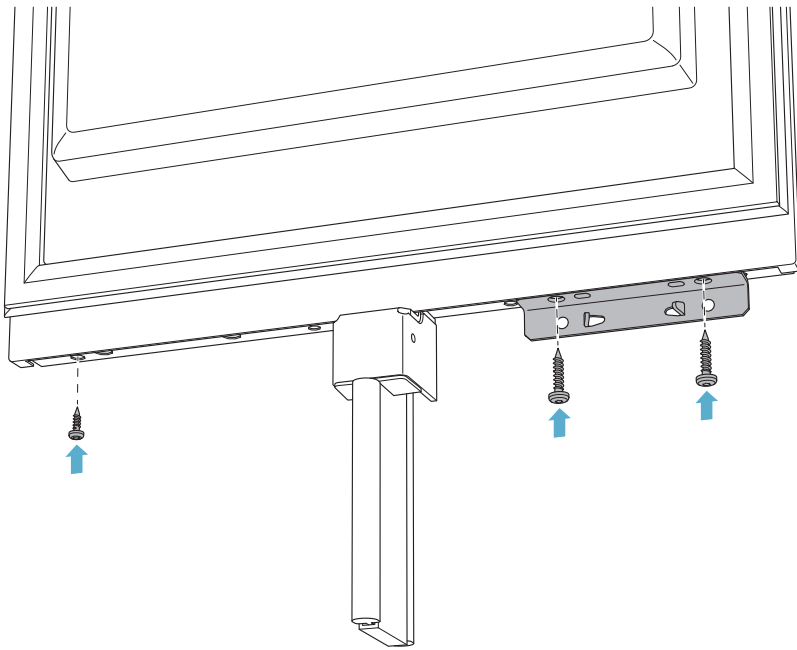

A
B
C
D

A

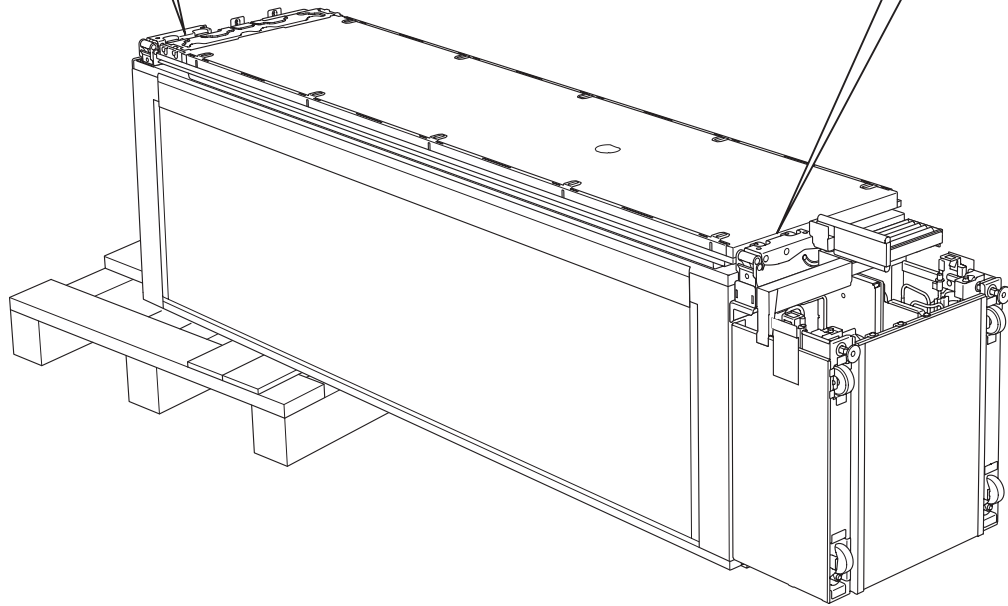
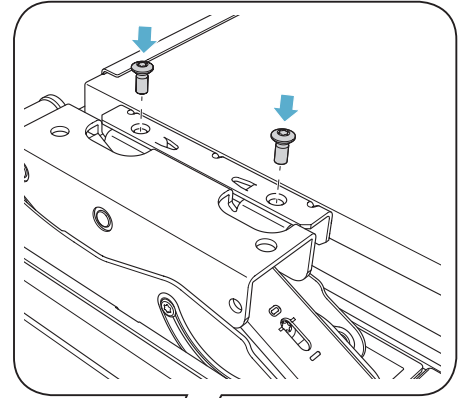
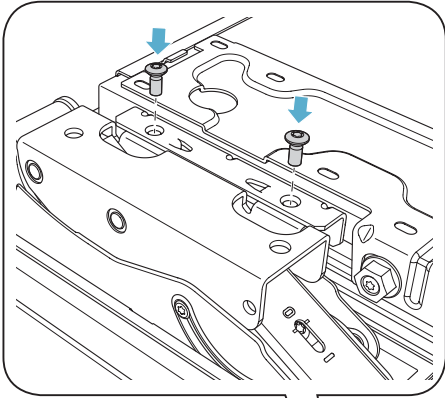

→ 46

B

A
B
C
D

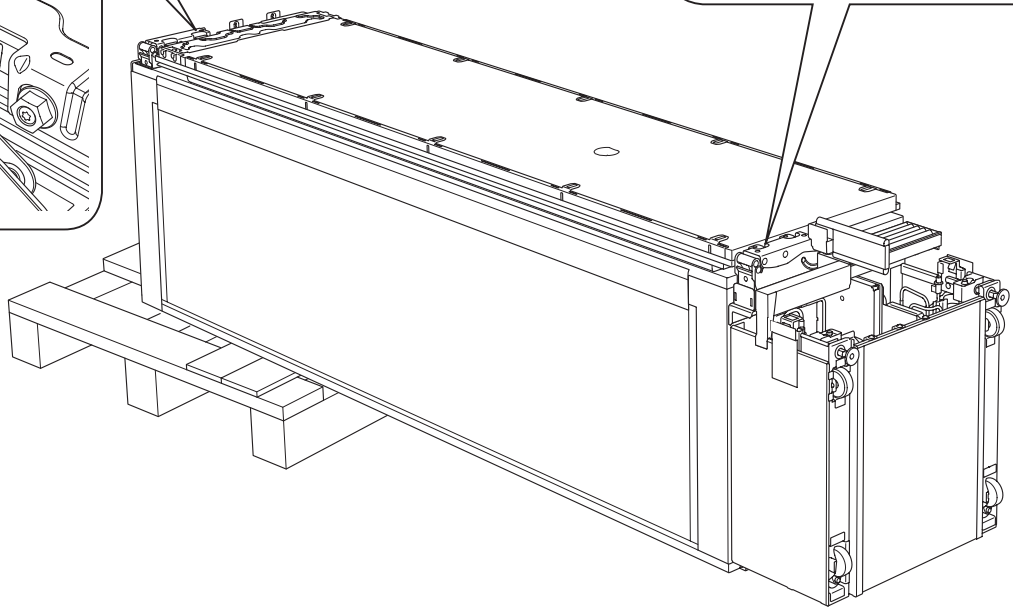
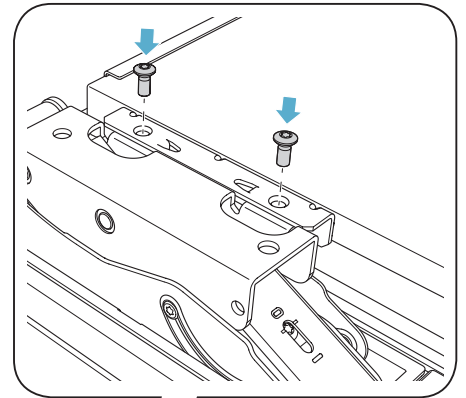
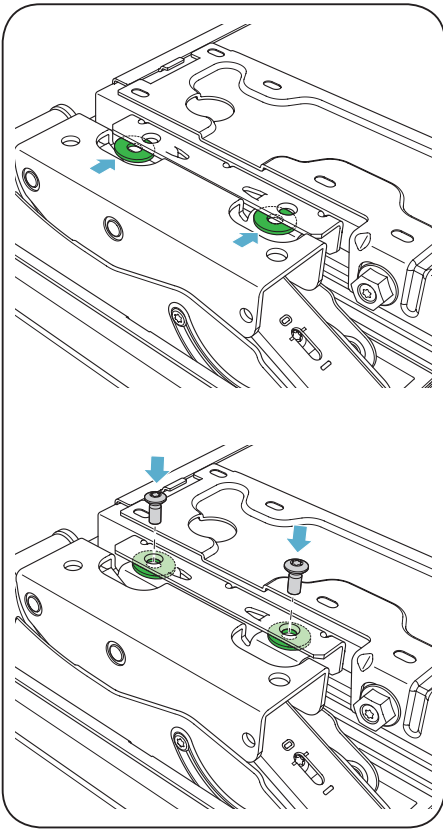
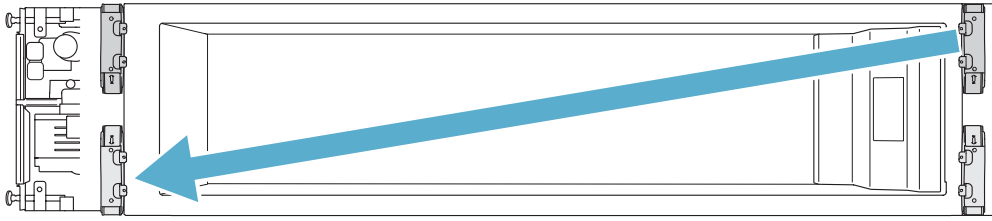

→ 46

A
B
C
D

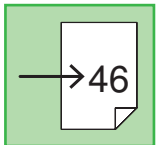
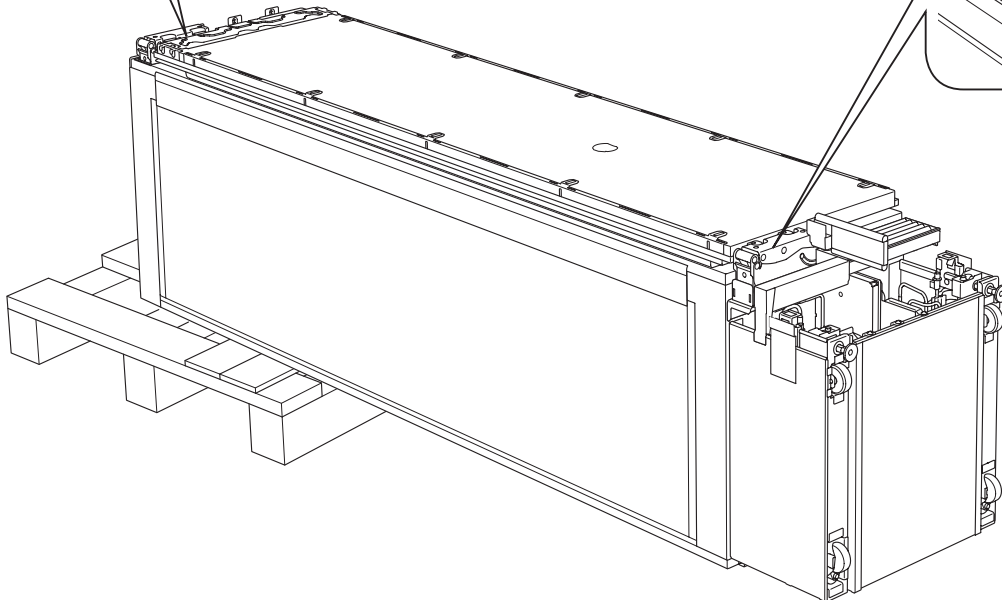
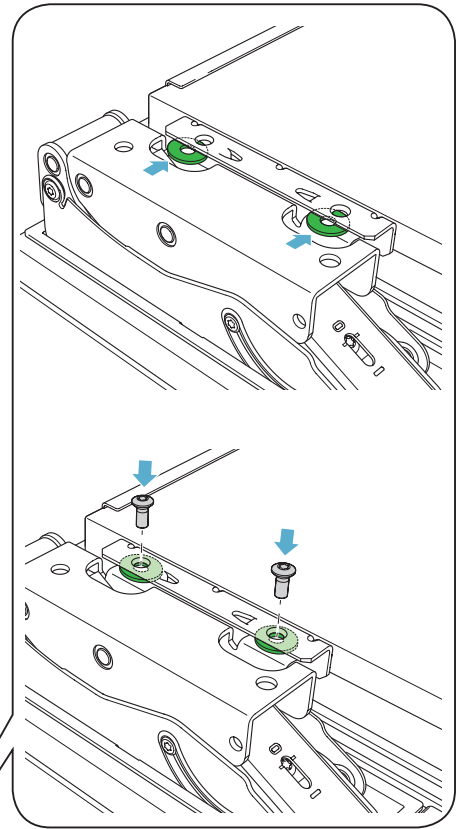
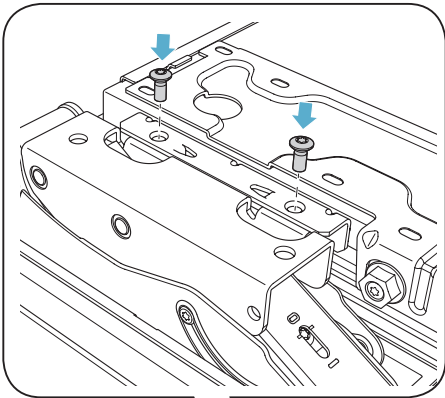
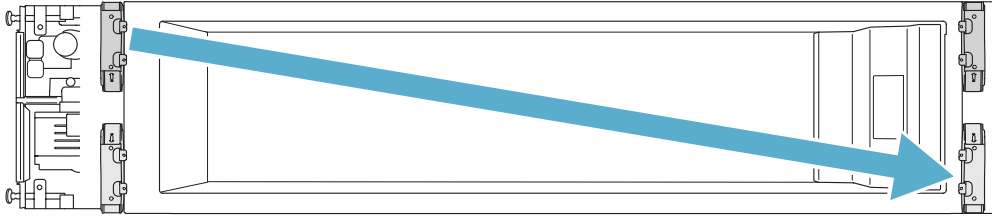

D

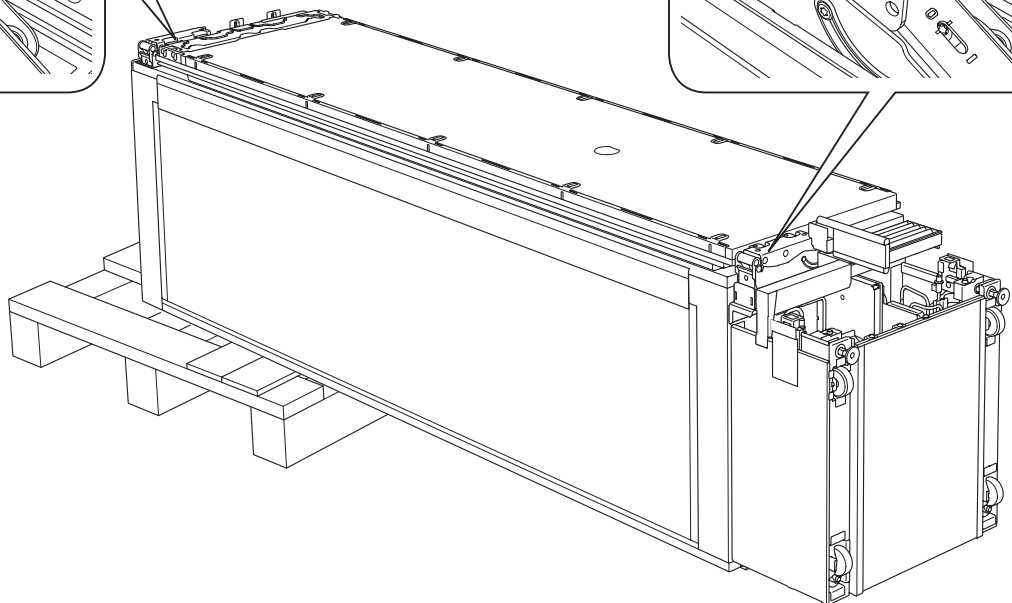
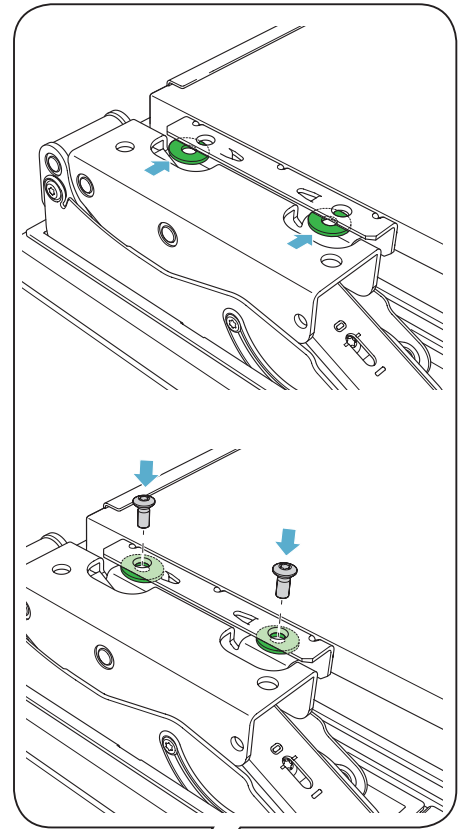
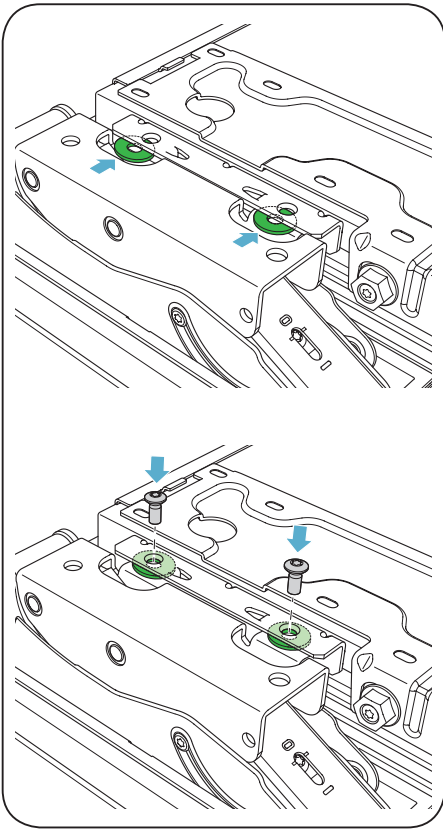
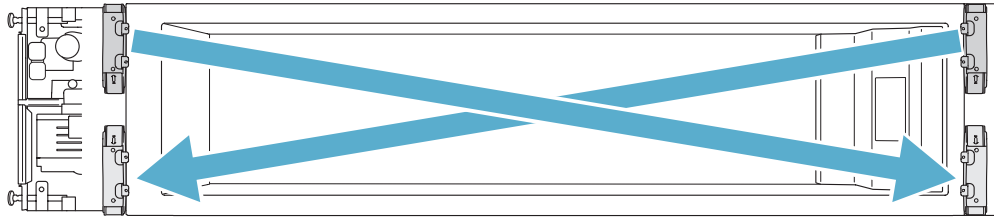

A
B
C
D

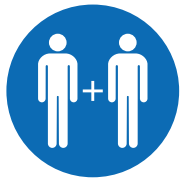
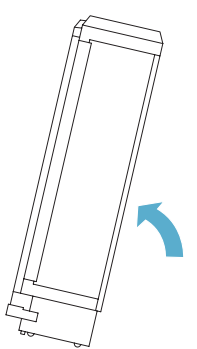
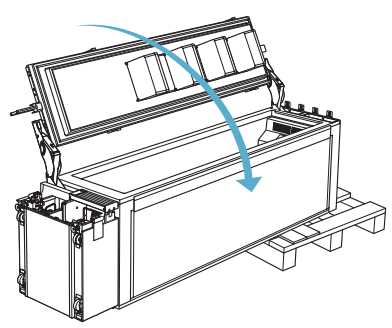
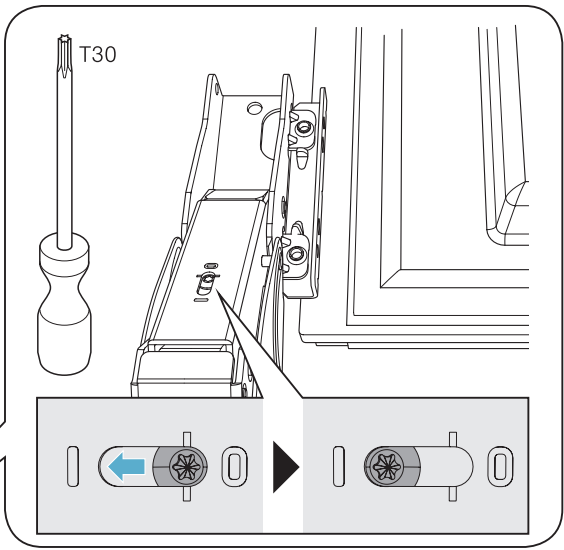
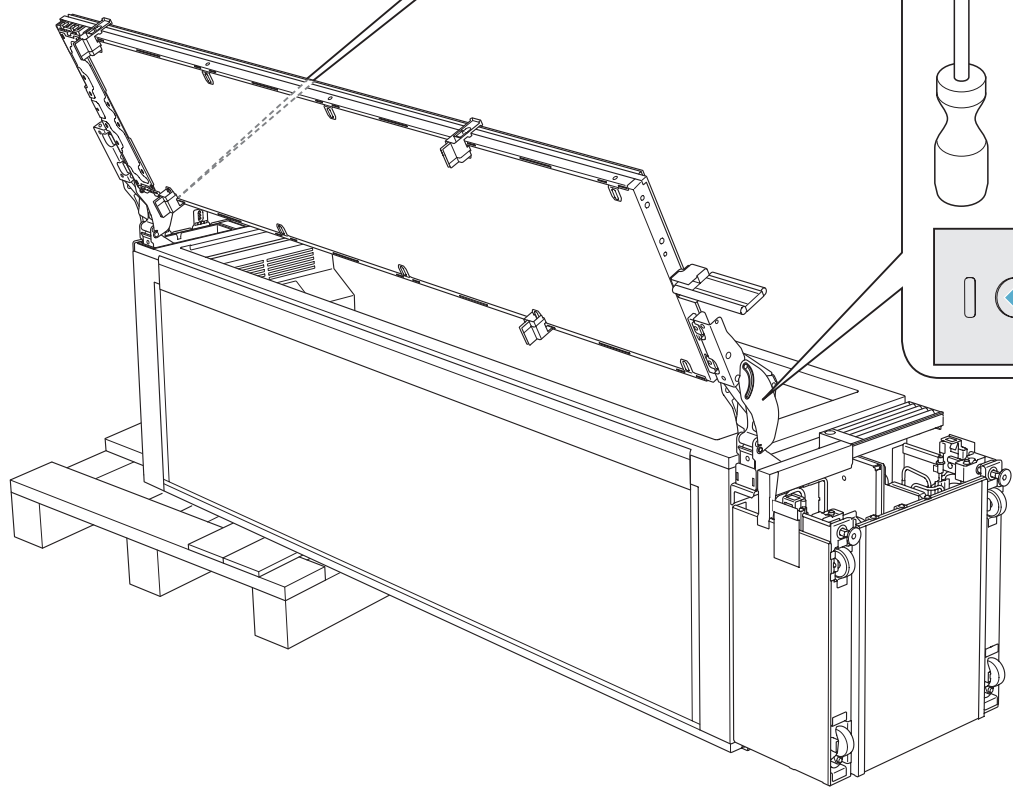
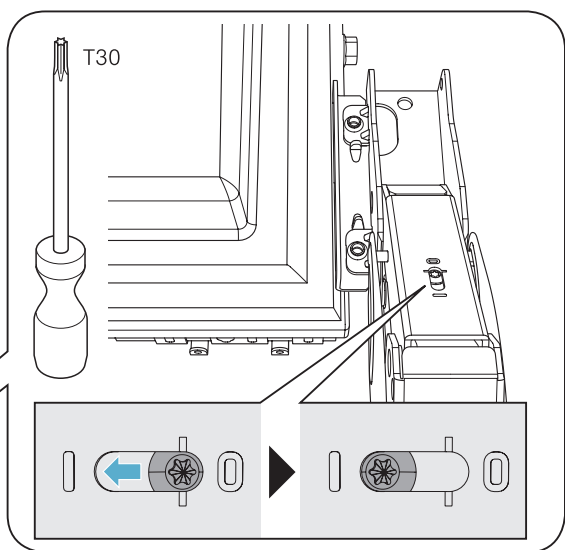
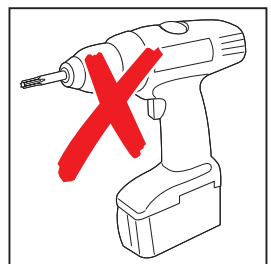
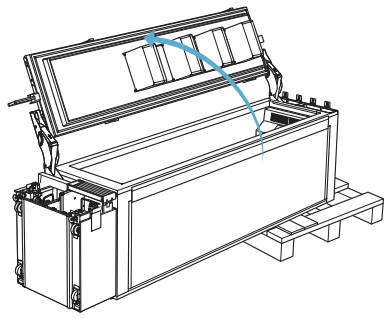

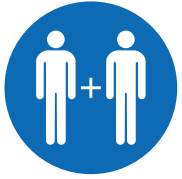

40

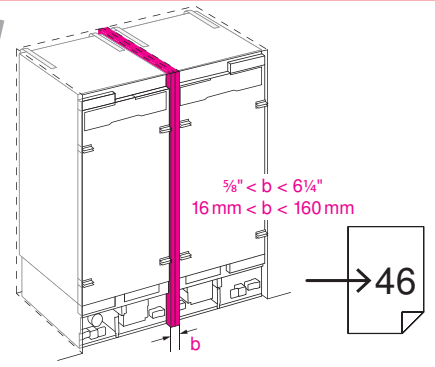
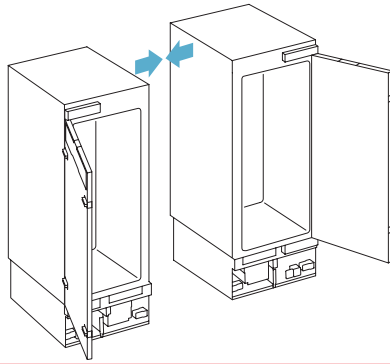

A
B
C
D

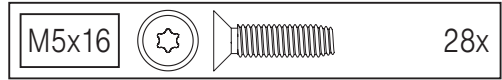
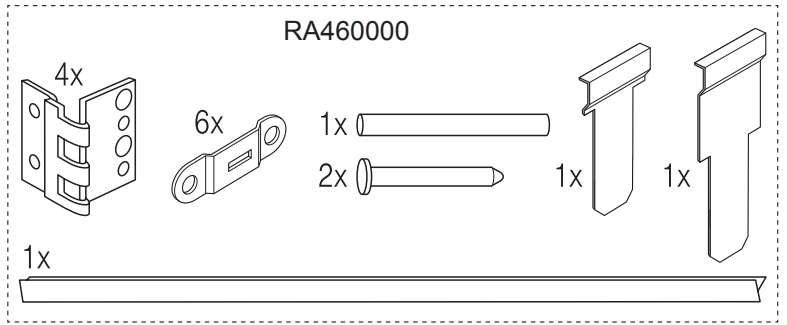
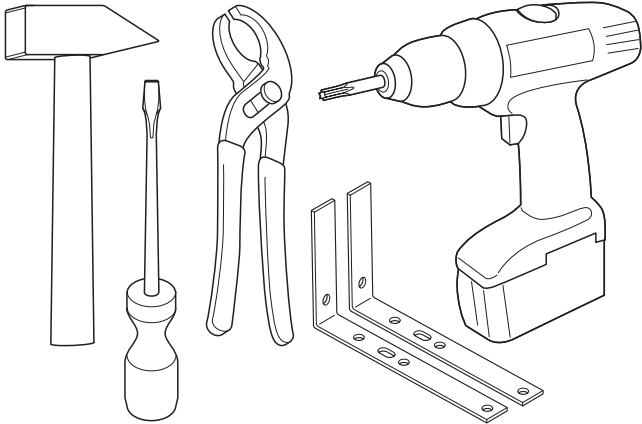

48

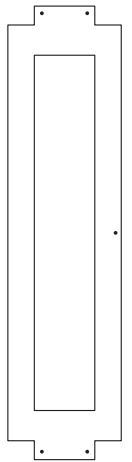
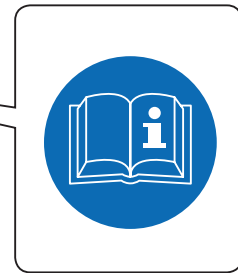
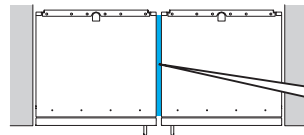

52

$\frac{5}{8}" \leq b < 6\frac{1}{4}"$
(16 mm \leq b < 160 mm)

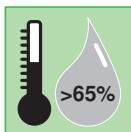
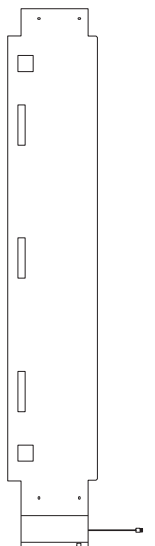
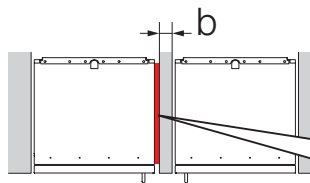

A

B

C

D

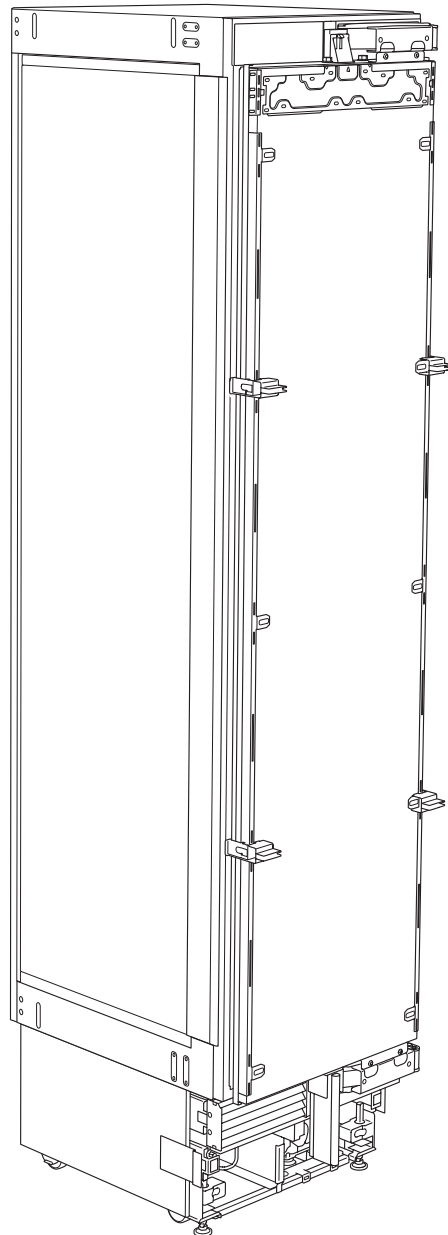
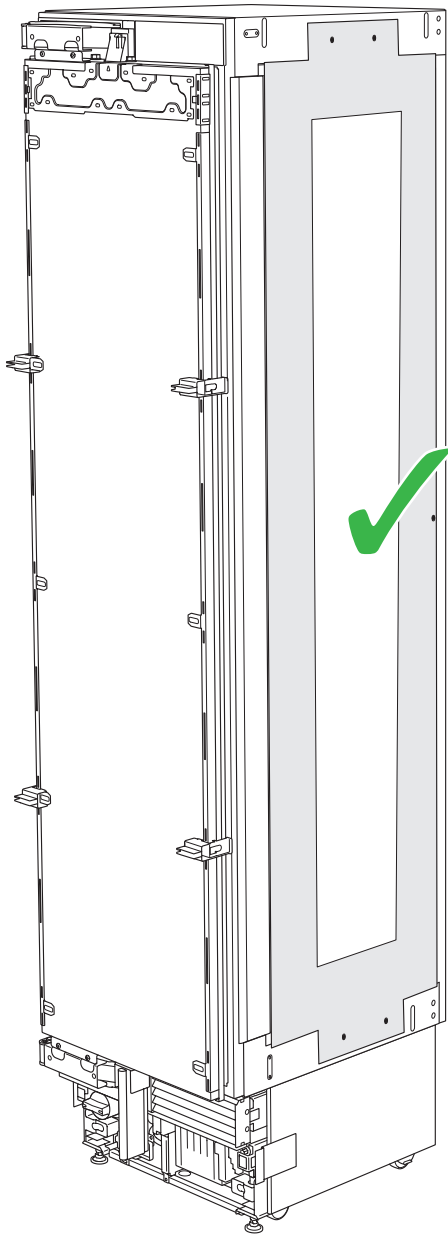
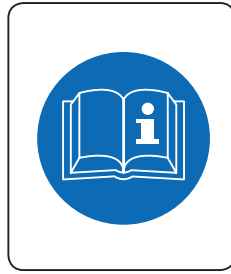
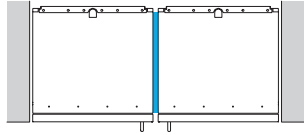

M5x16



12x

A

B

C

D

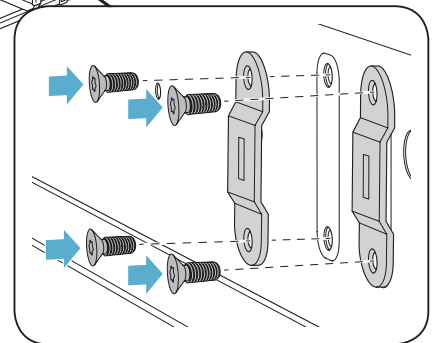
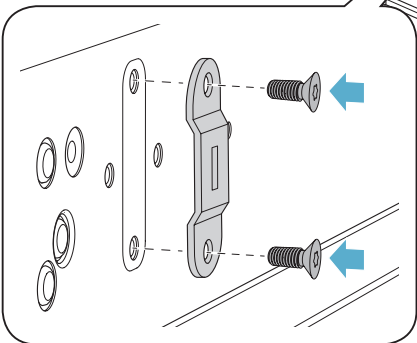
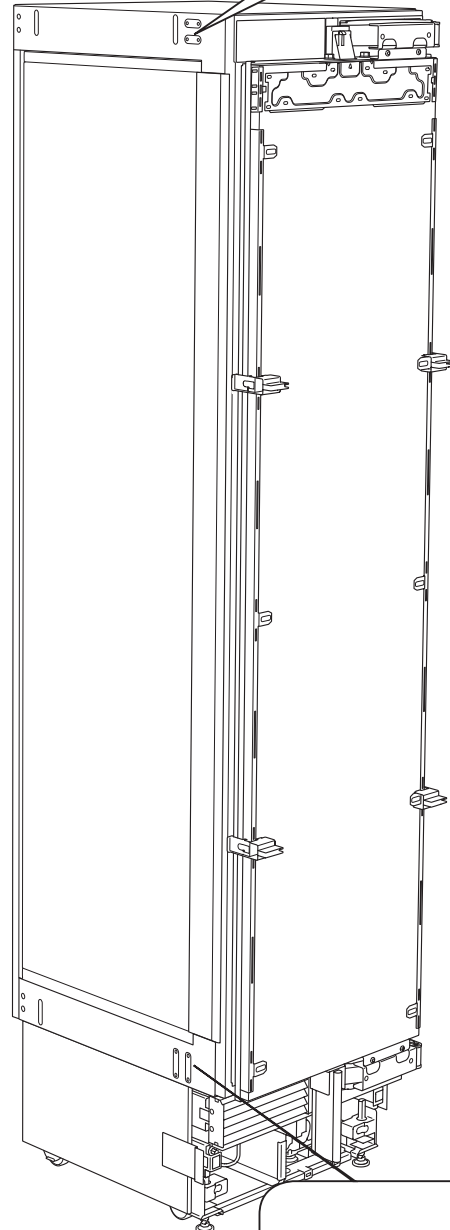
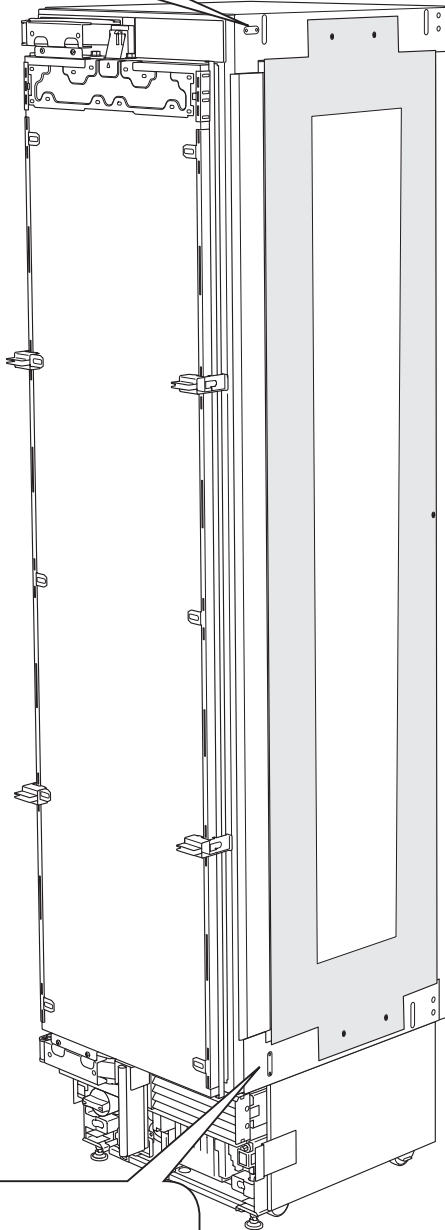
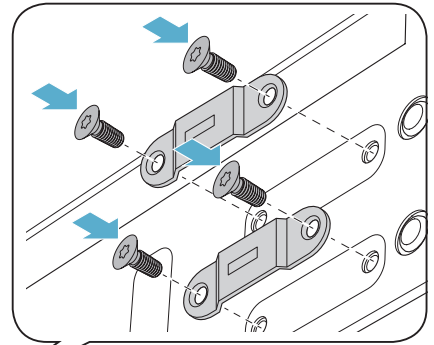
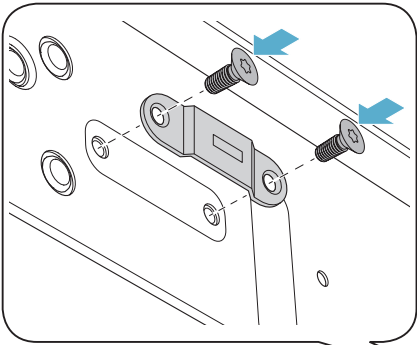



A

B

C

D

M5x16   16x

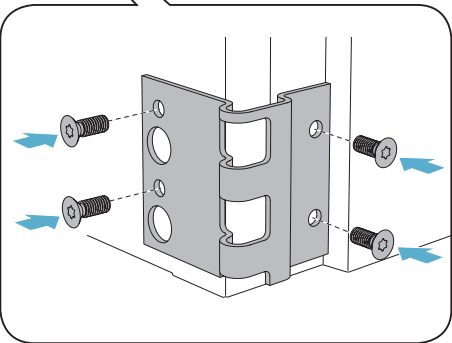
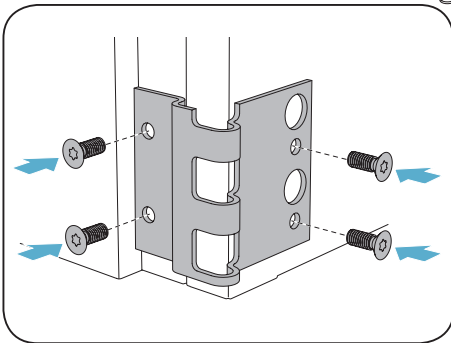
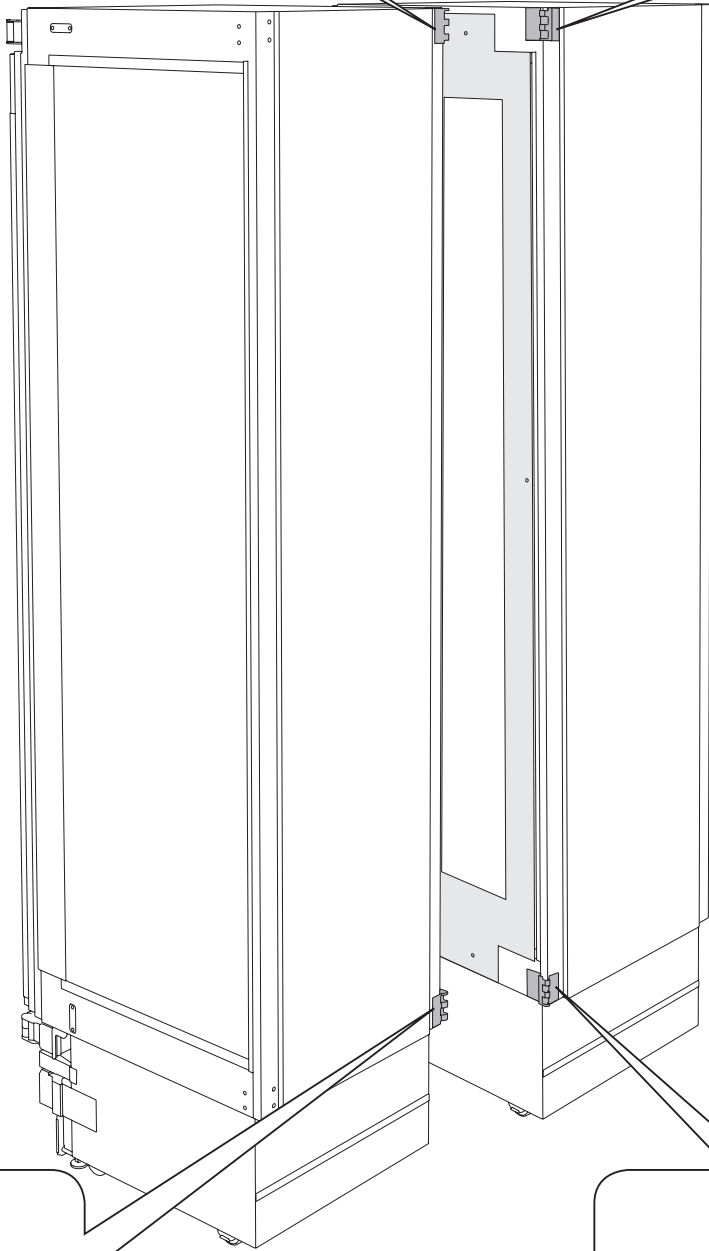
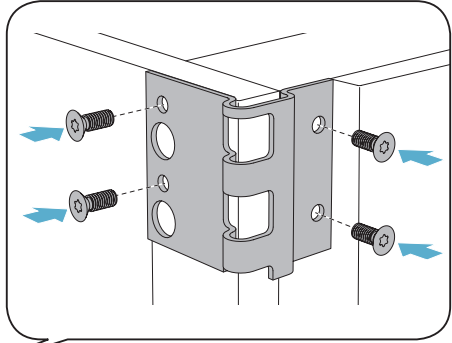
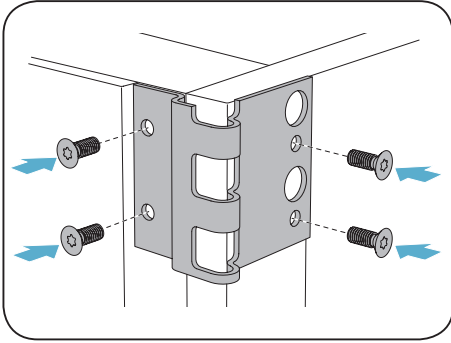

A

B

C

D

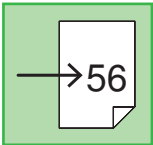
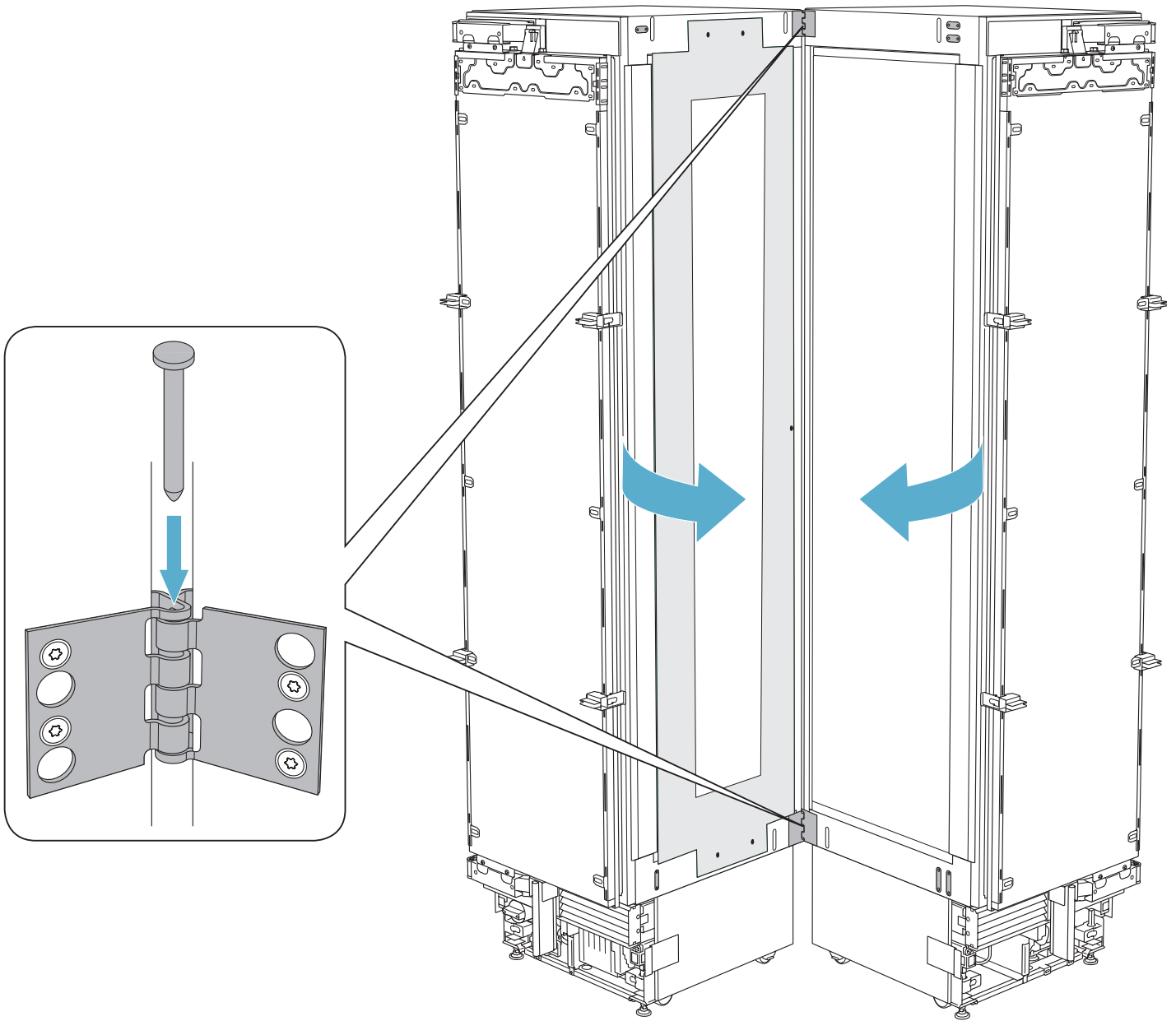

A
B
C
D

$\frac{5}{8}'' \leq b < 6\frac{1}{4}''$
(16 mm \leq b < 160 mm)

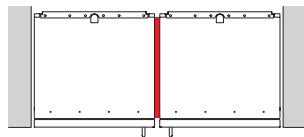
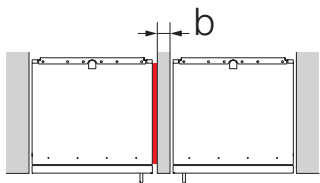
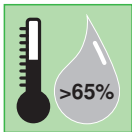



EN: When the appliances are installed less than 6¹/₄" (160 mm) apart from one another, but not connected side-by-side, purchase the heater kit **RA 460012** (Freedom Heater Kit). This kit is also recommended for use with any installation in areas that are subject to extreme humidity.

FR: Pour les appareils encastrés qui sont à moins de 6¹/₄" pouces (160 mm) l'un de l'autre, mais qui ne sont pas reliés entre eux, il faut acheter la trousse chauffage **RA 460012** (Freedom Heater Kit) en sus. Cette trousse est recommandée pour les installations dans les zones extrêmement humides.

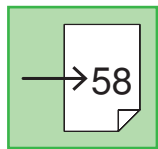
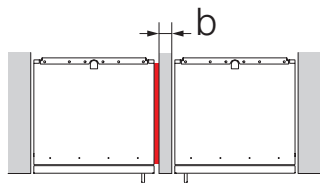
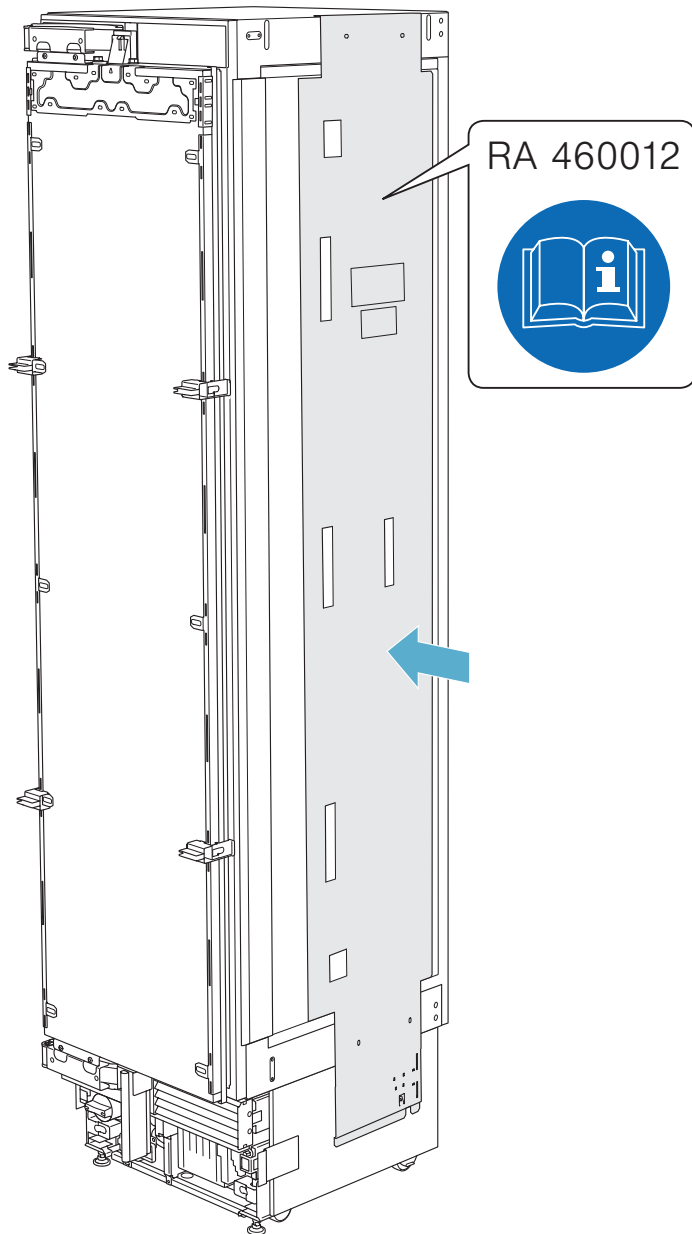
ES: Sí los aparatos que están empotrados a una distancia inferior a 6¹/₄" pulgadas (160 mm) entre ellos, pero que no están unidos entre sí, rogamos que se compre además el juego de piezas de calefacción **RA 460012** (Freedom Heater Kit). Este juego de piezas es recomendable también para el montaje en áreas extremadamente húmedas.



M5x16   12x

A
B
C
D

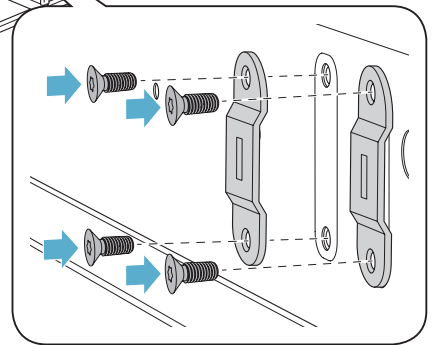
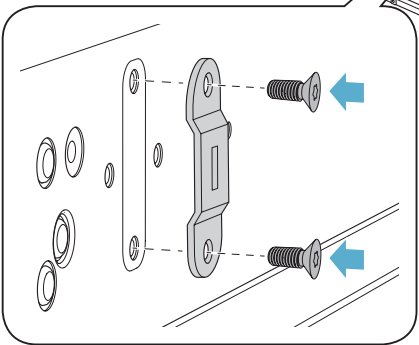
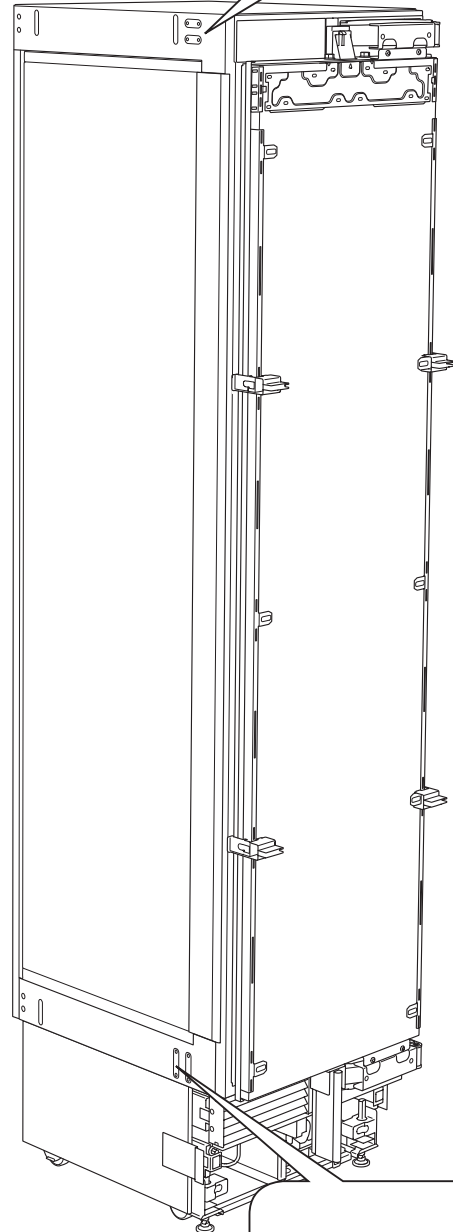
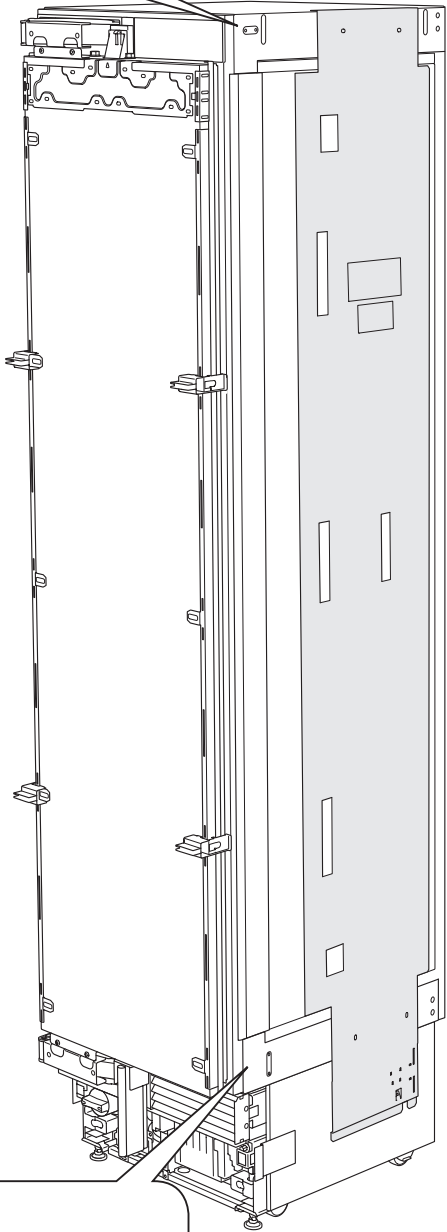
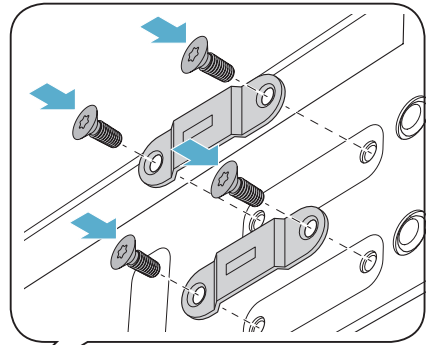
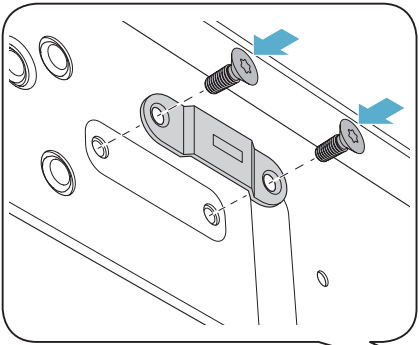

A

B

C

D

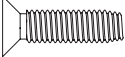
M5x16   16x

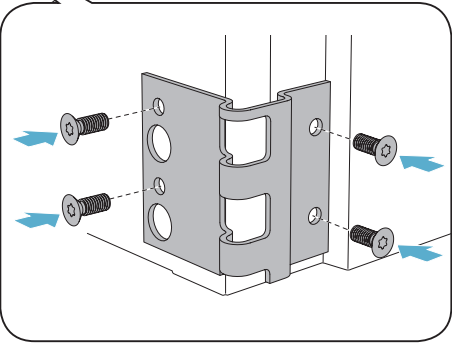
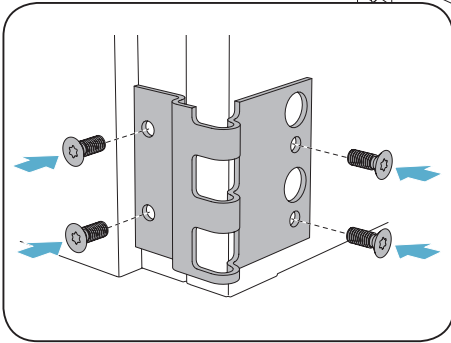
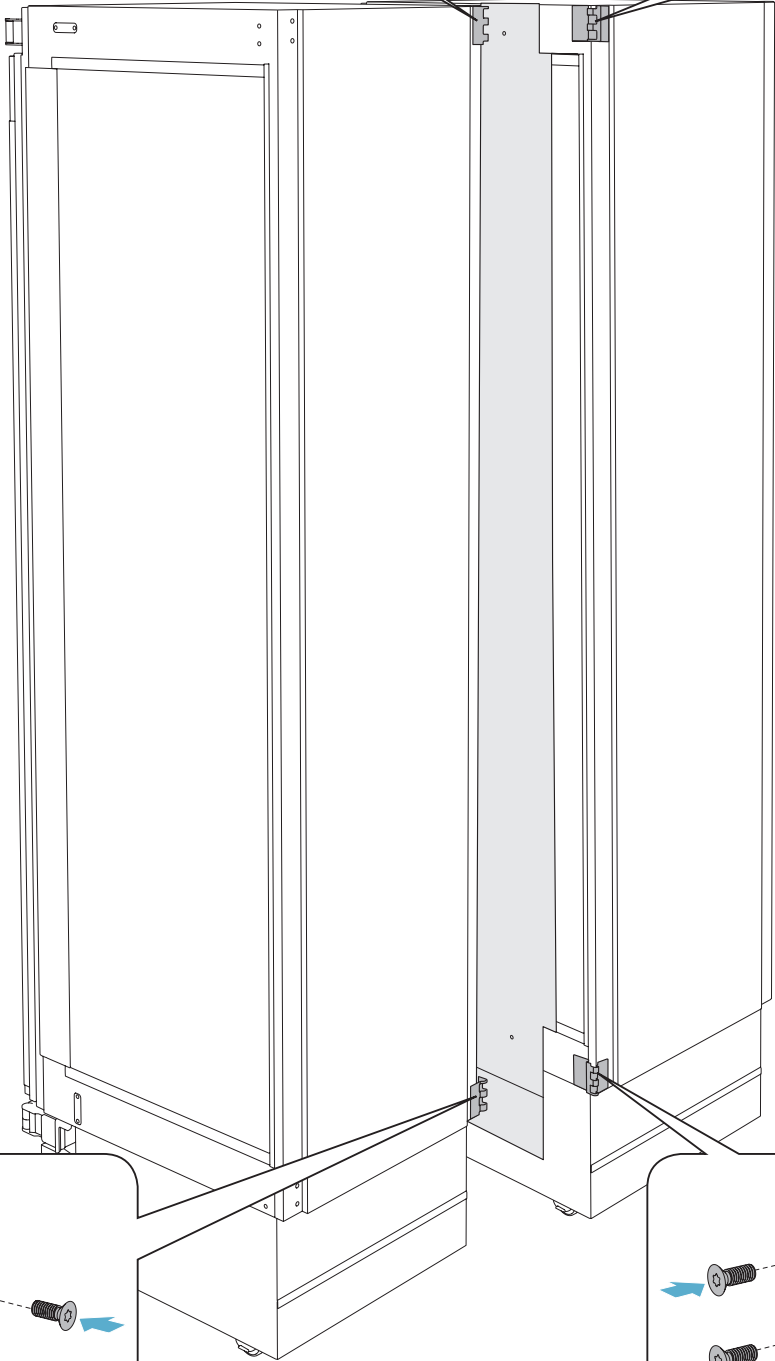
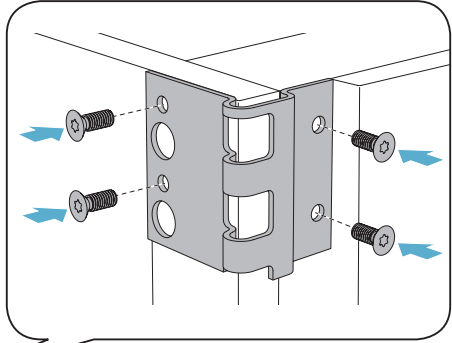
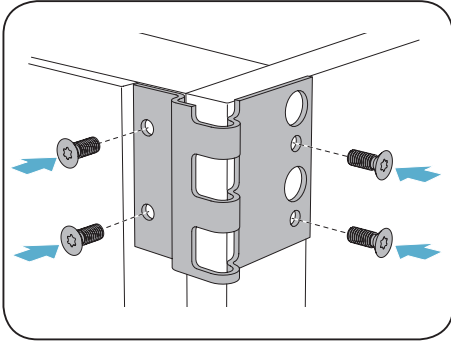

A

B

C

D

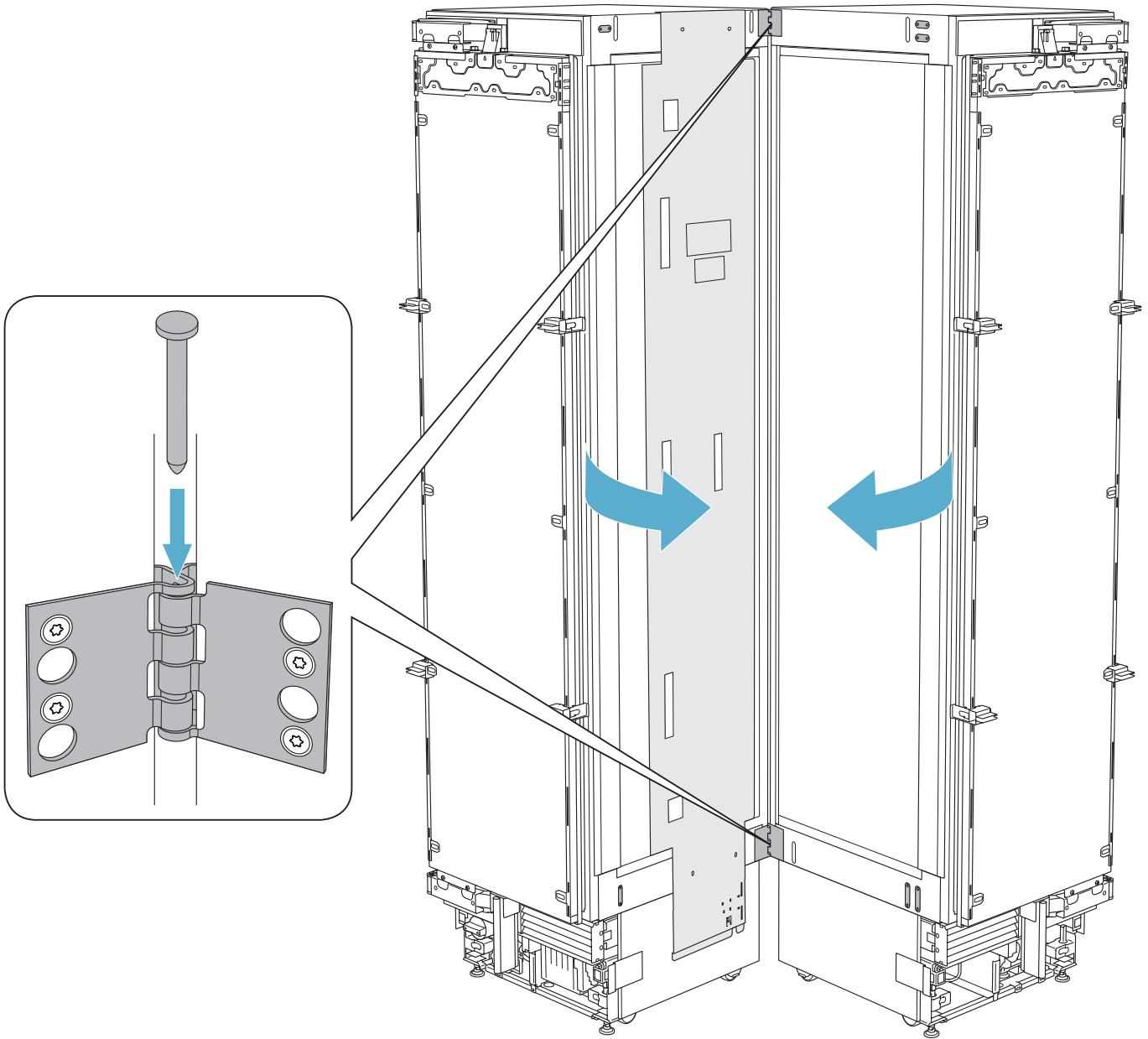

A
B
C
D

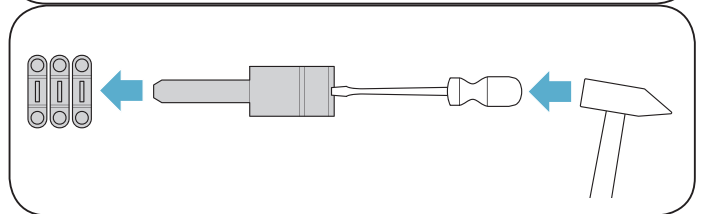
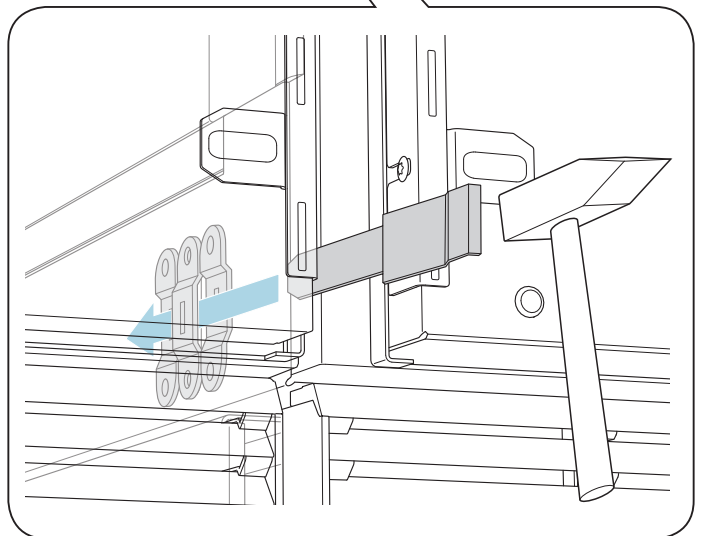
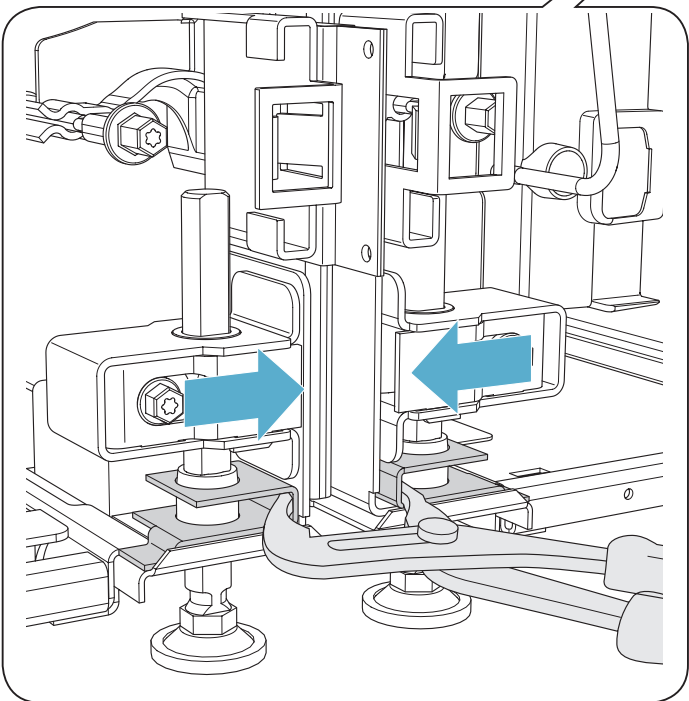
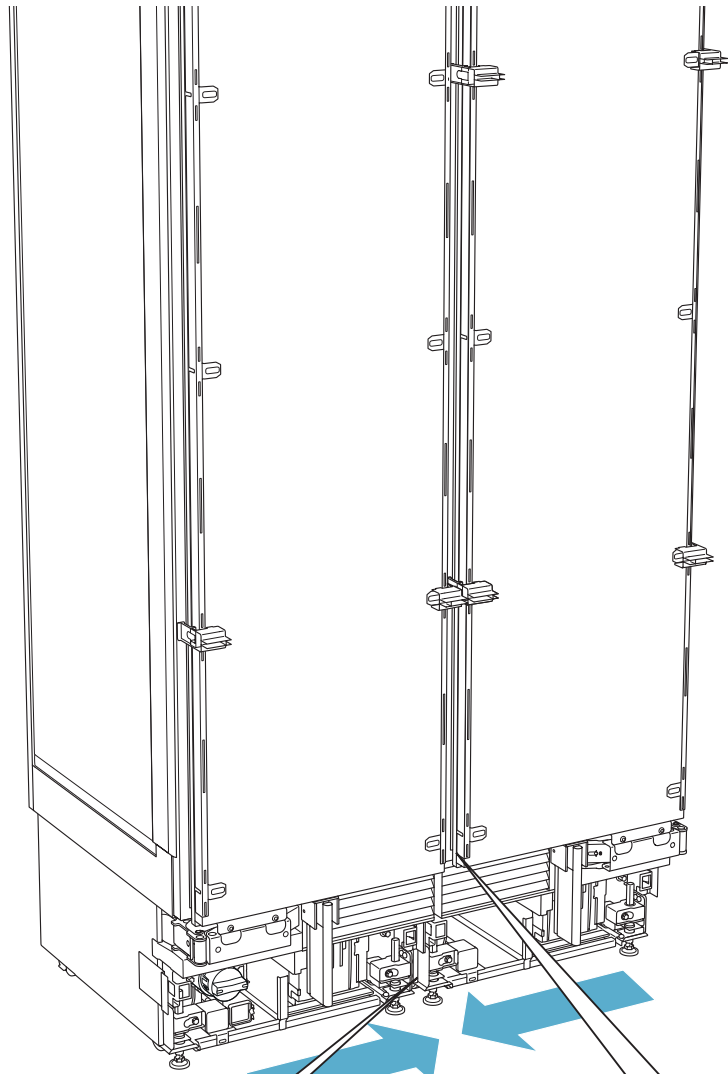
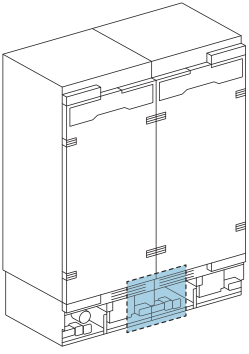

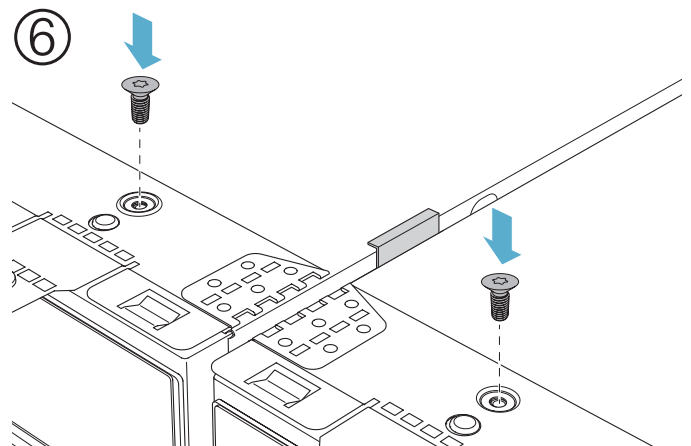
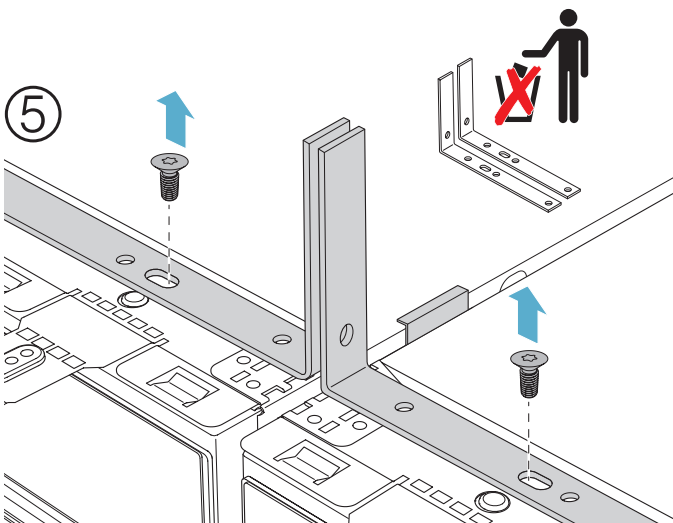
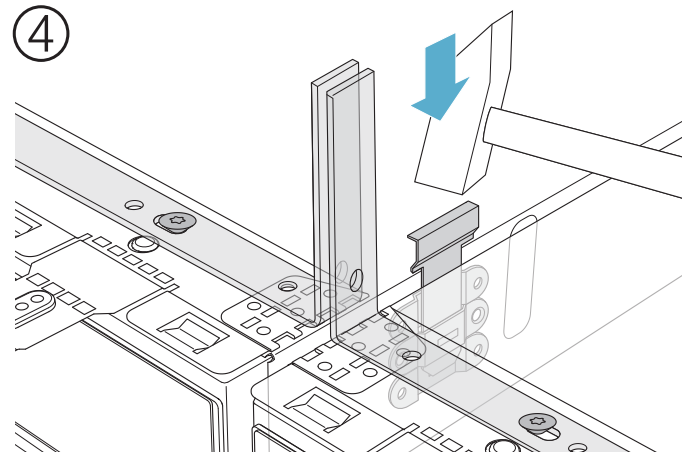
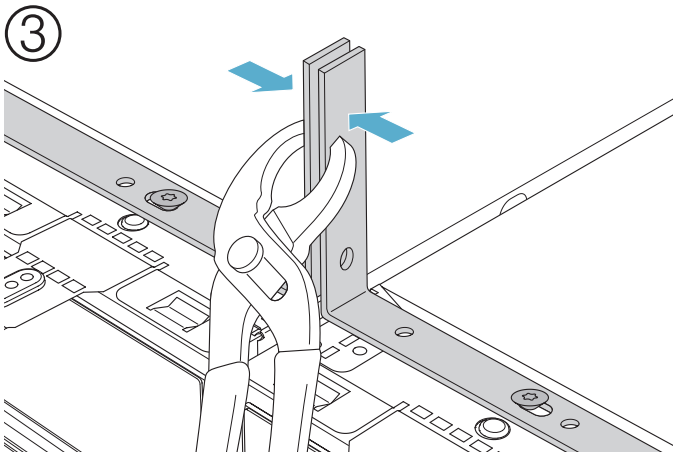
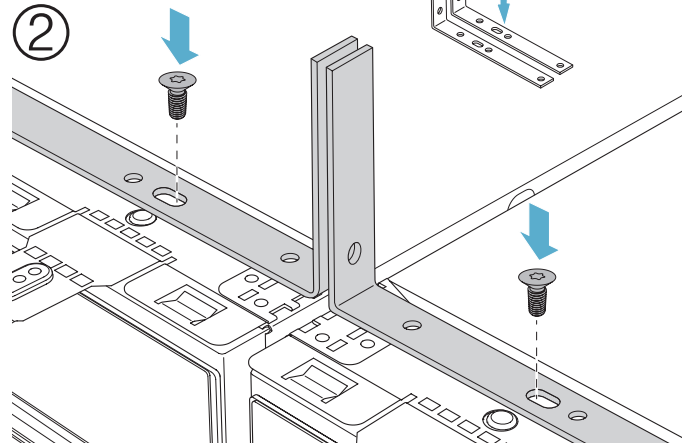
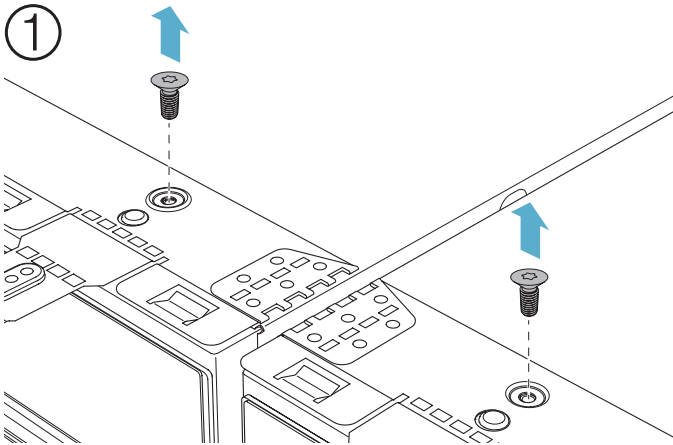
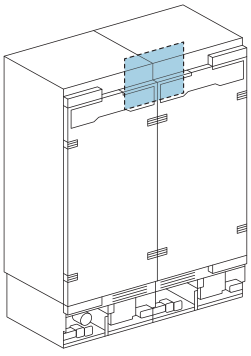

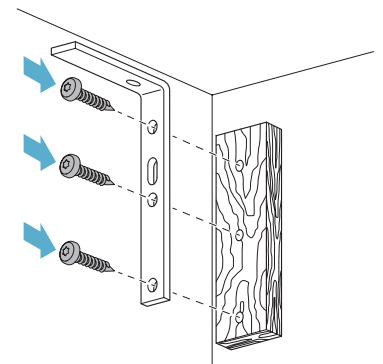
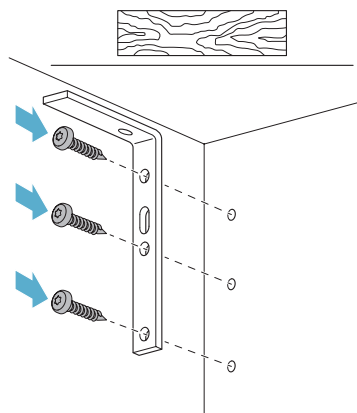
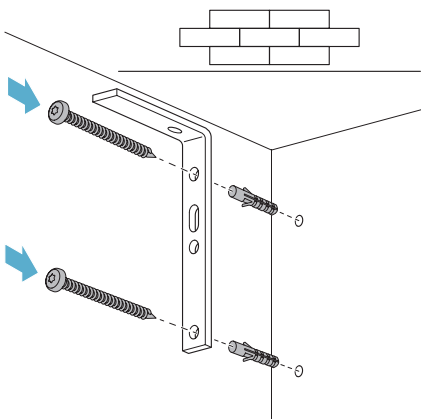
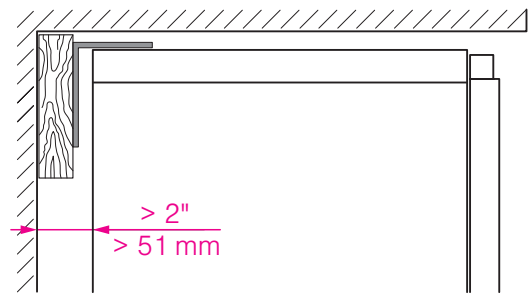
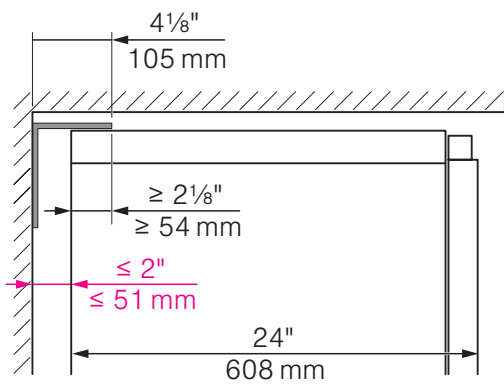
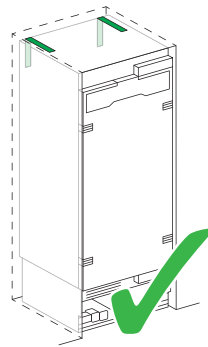
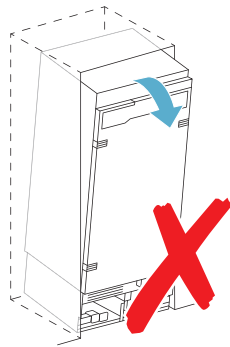
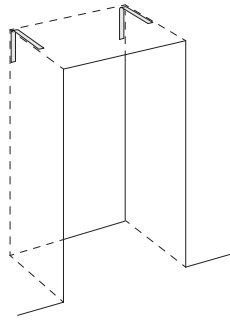

5x60			4x
6x31			4x

4x15			6x
------	--	--	----

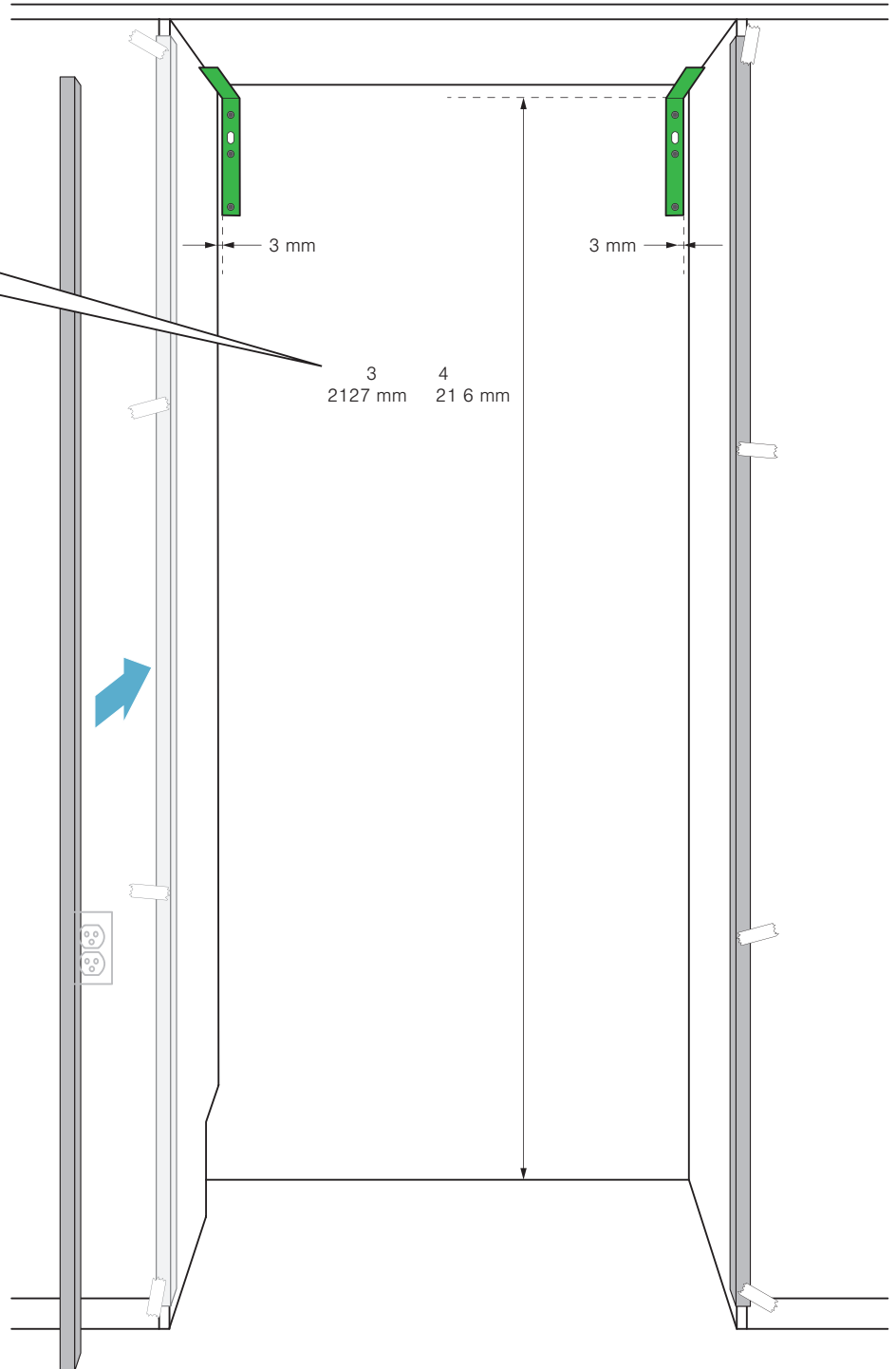
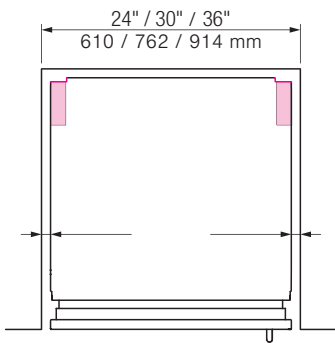
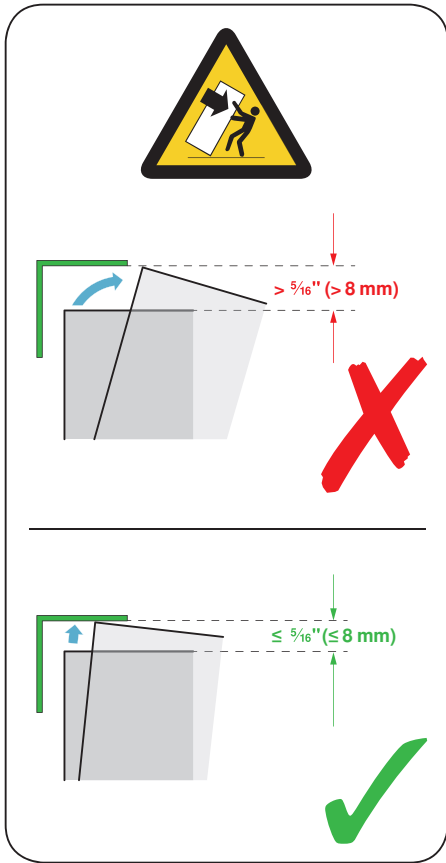
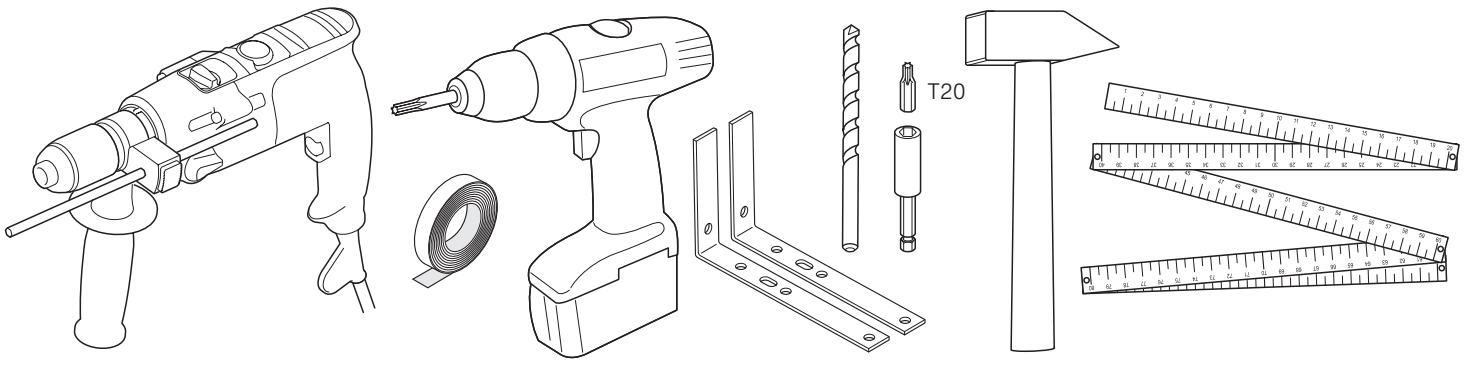

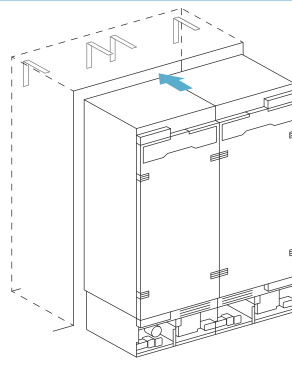
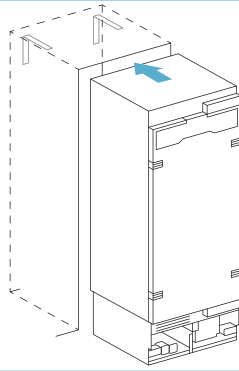
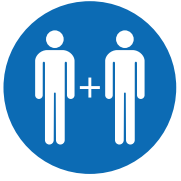

A

B

C

D

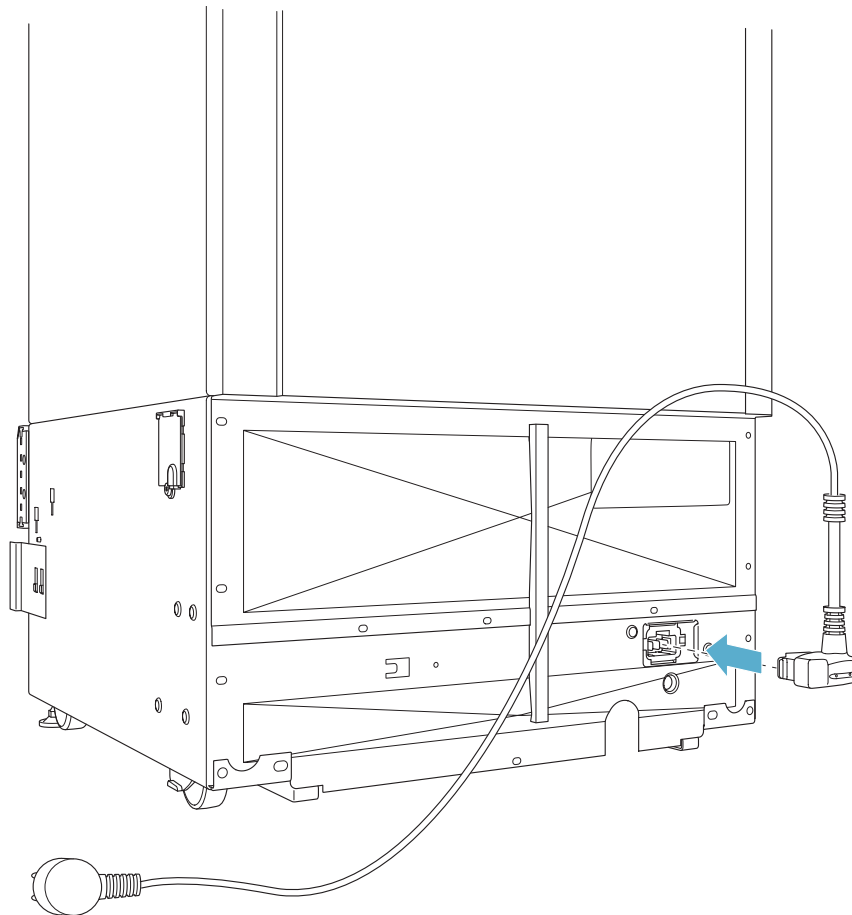
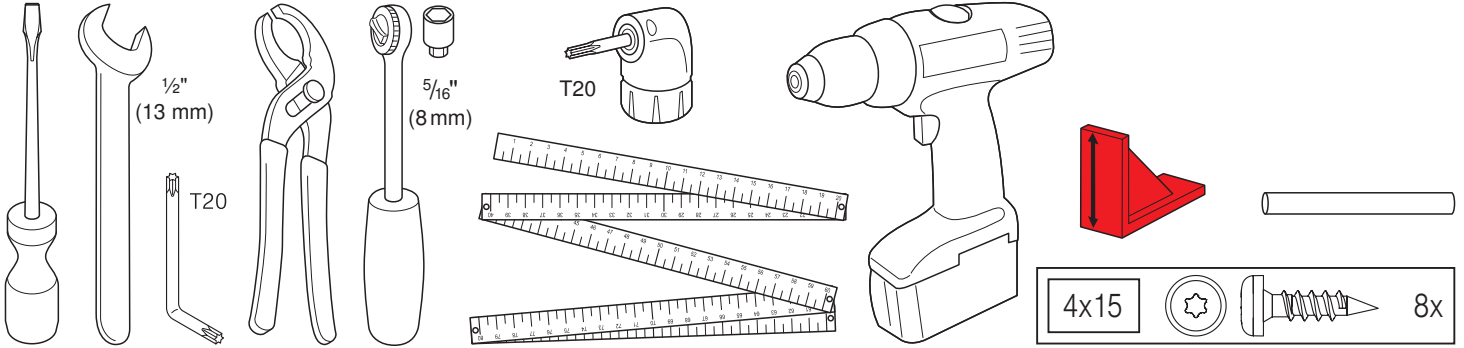

- A
- B
- C
- D

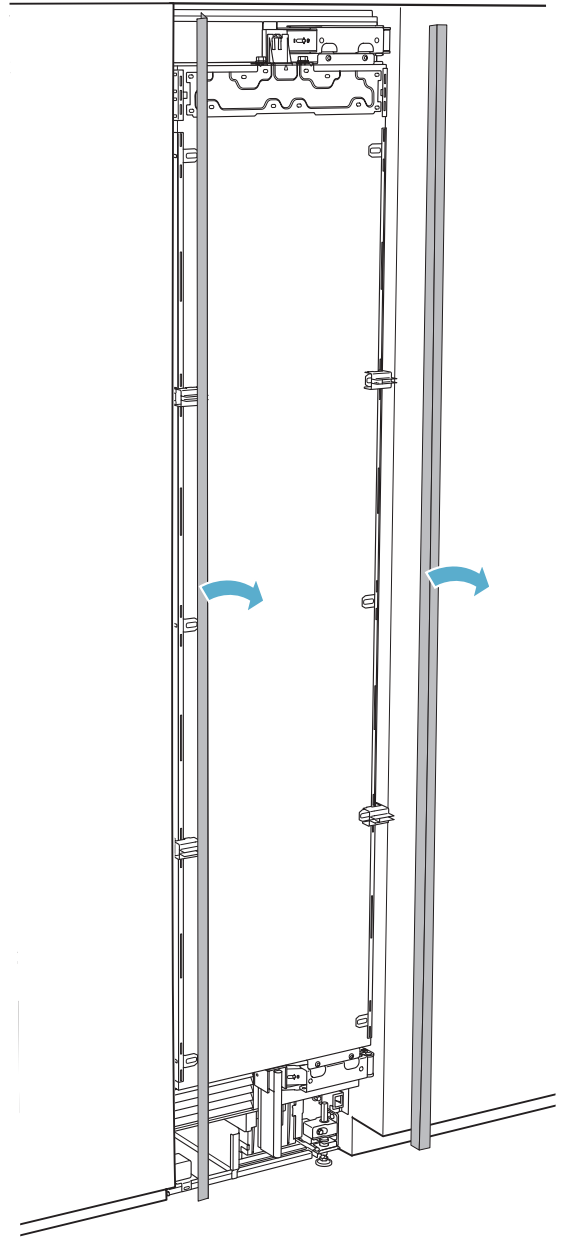
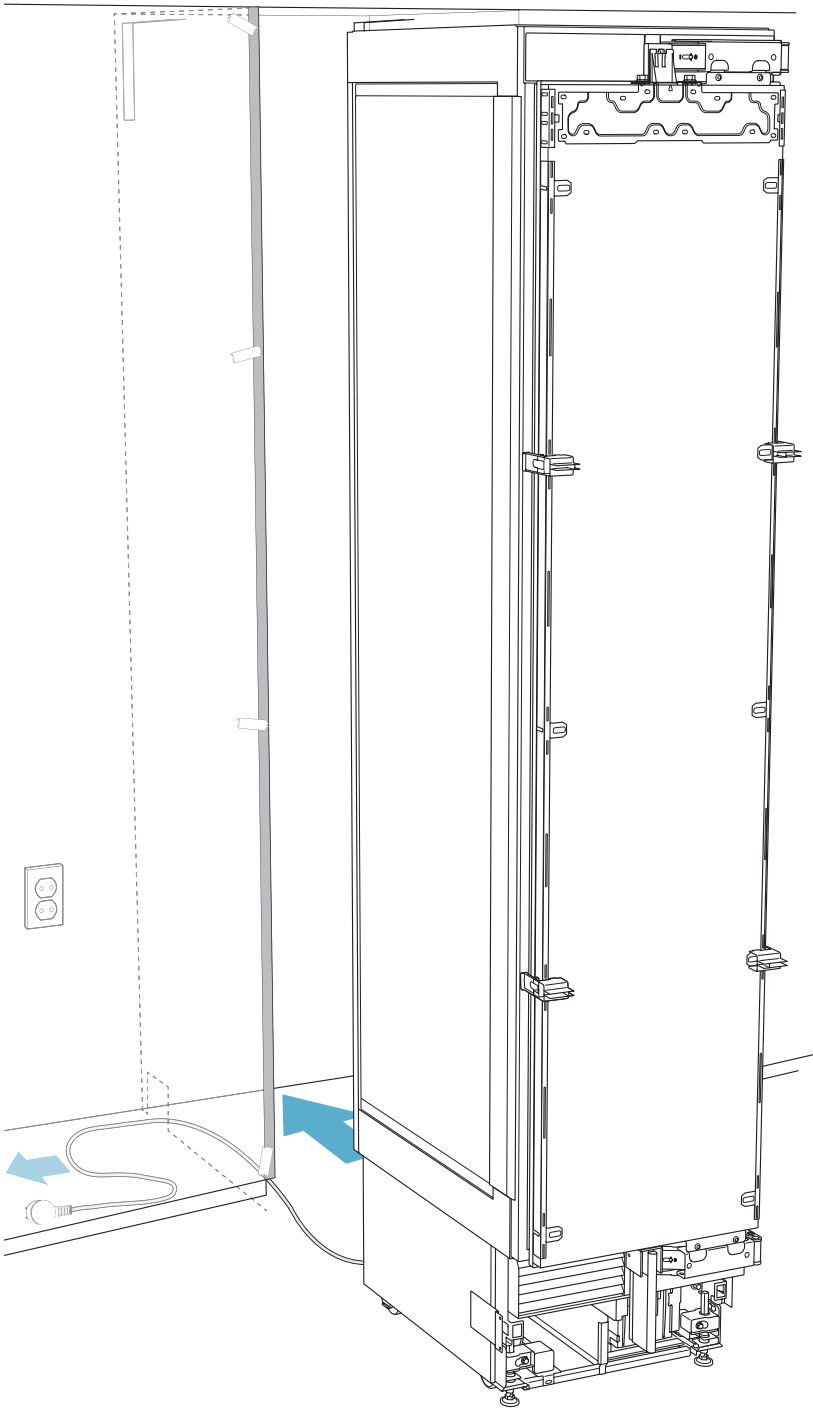
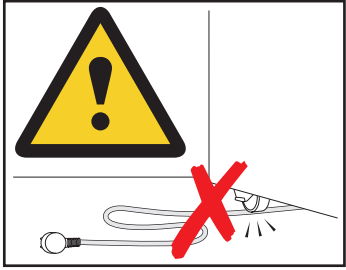

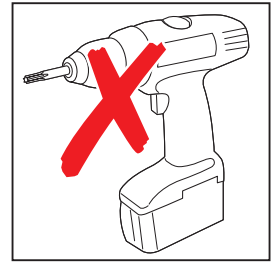
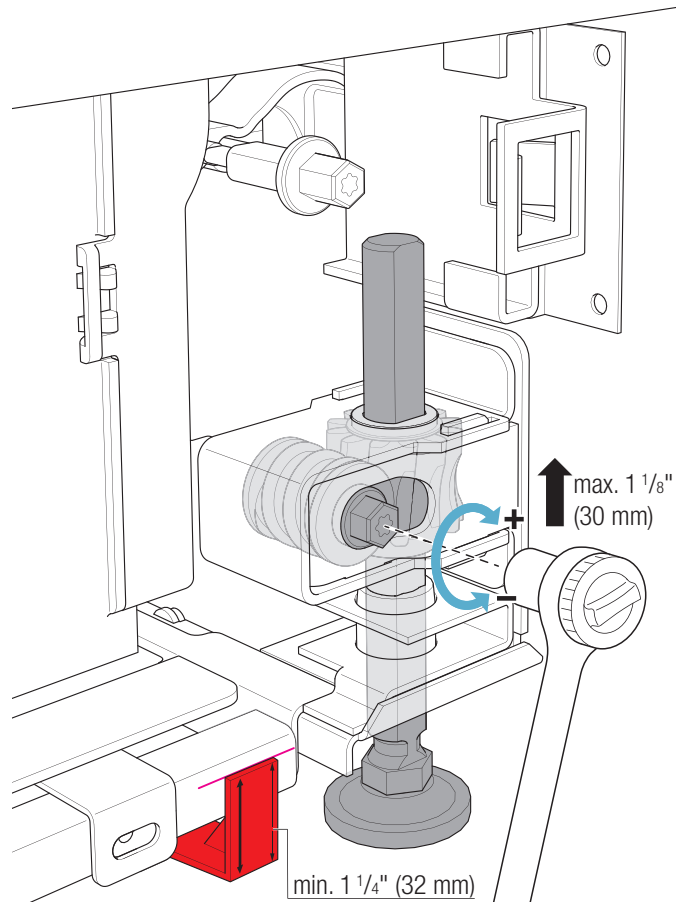
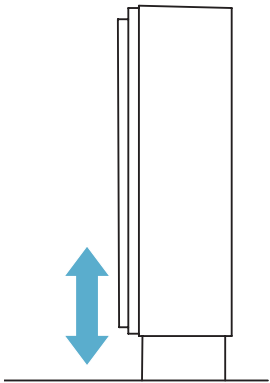
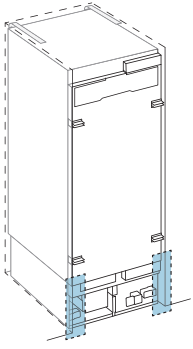

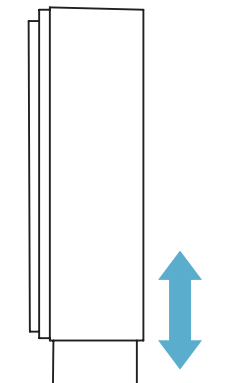
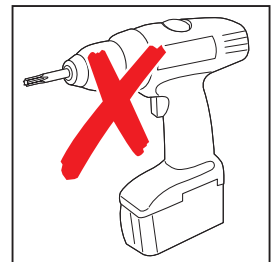
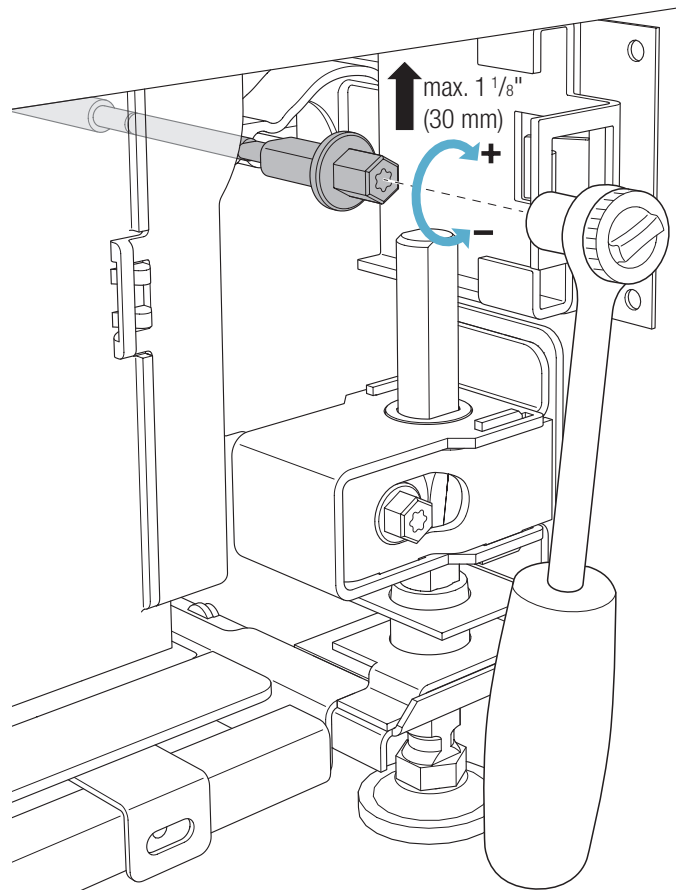

- A
- B
- C
- D

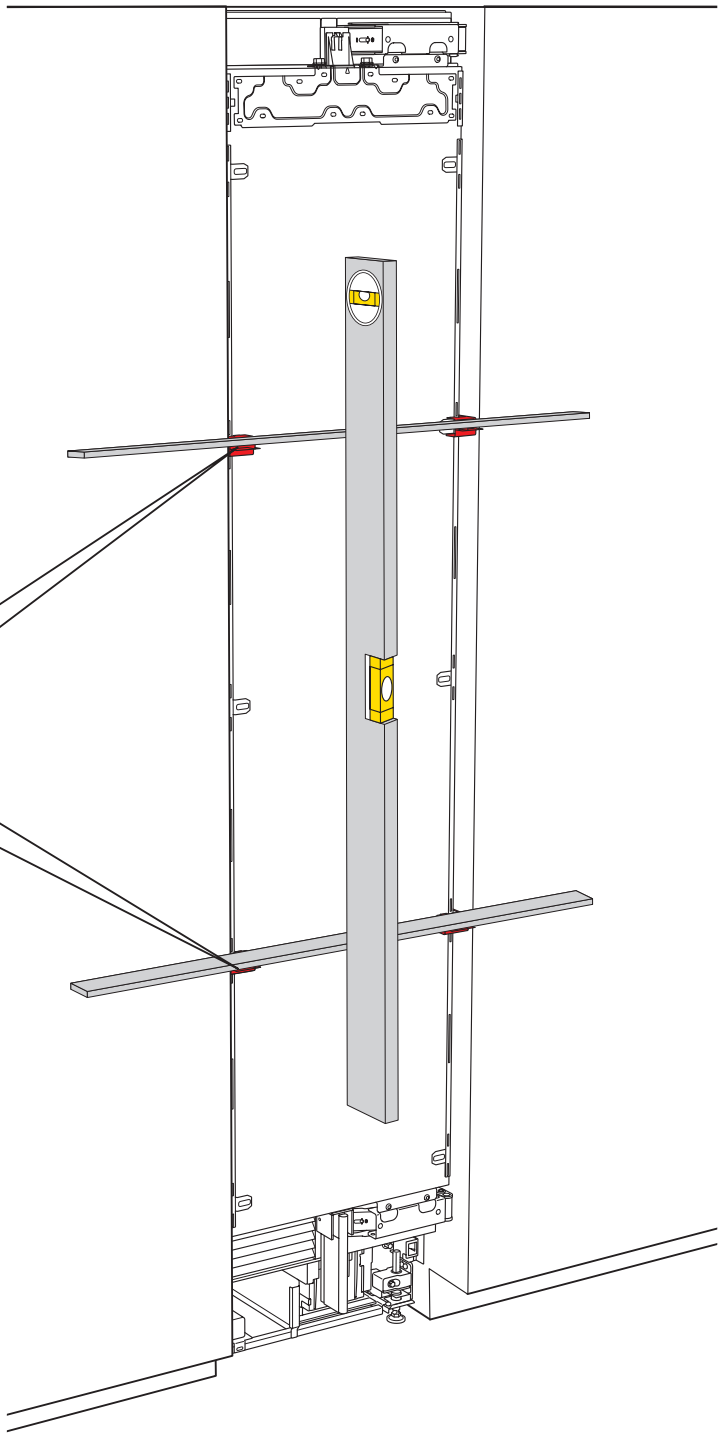
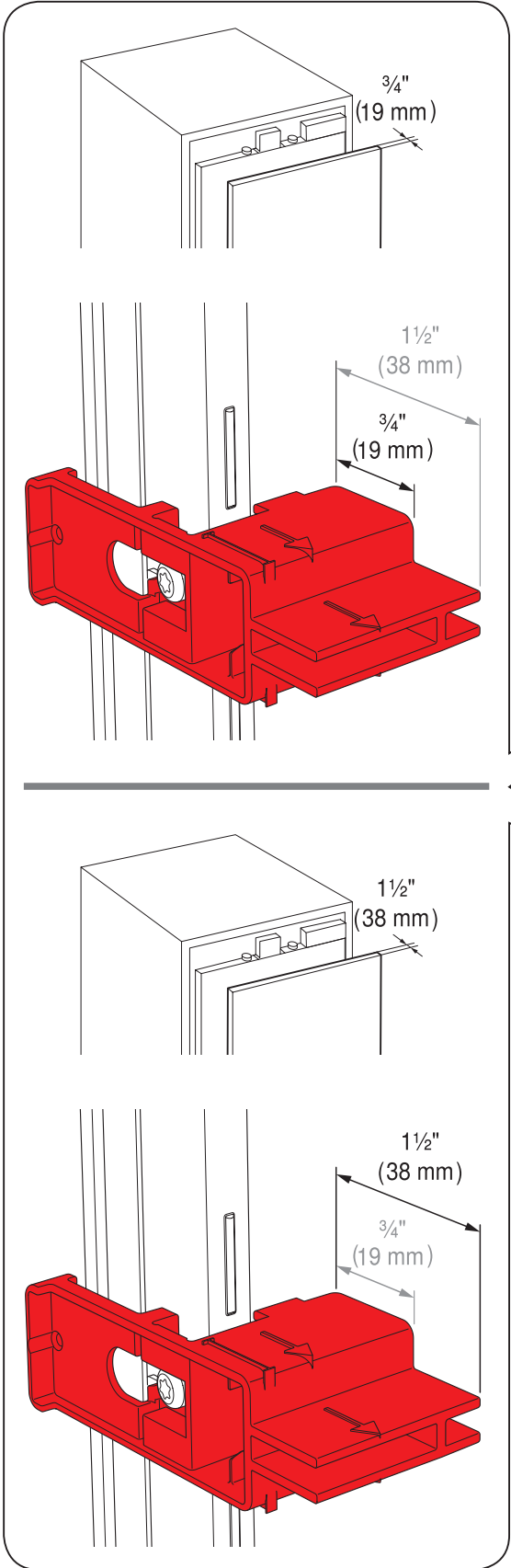

- A
- B
- C
- D

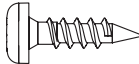

4x15   8x

A
B
C
D

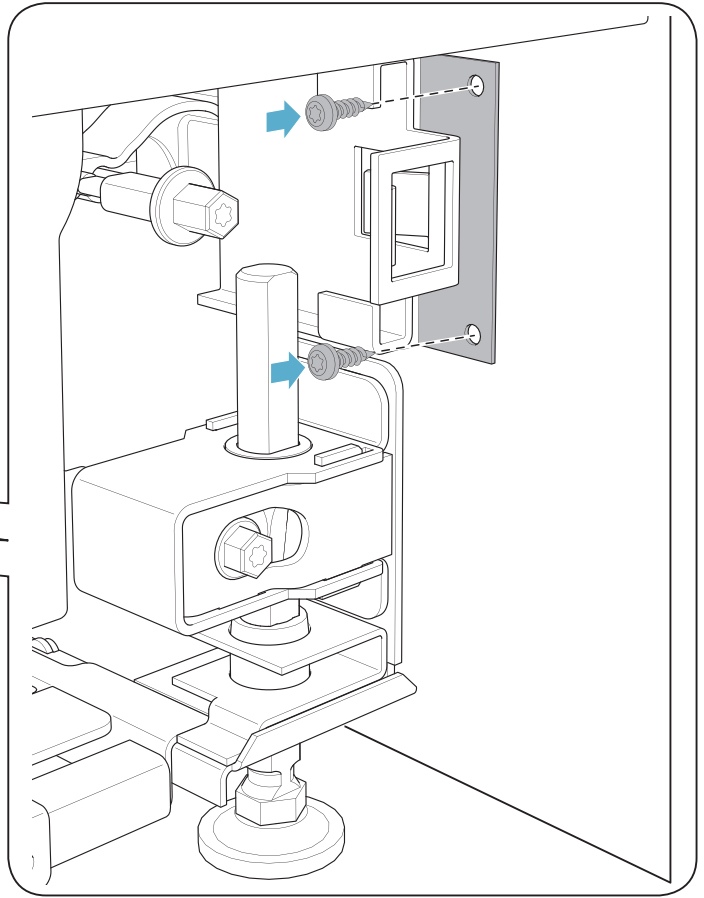
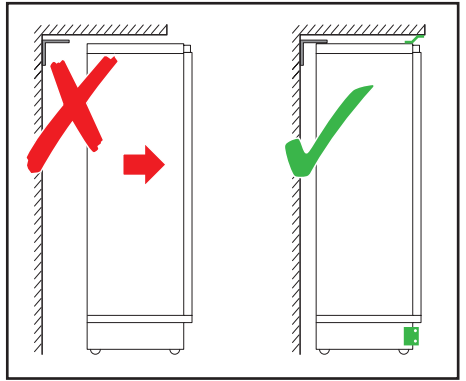
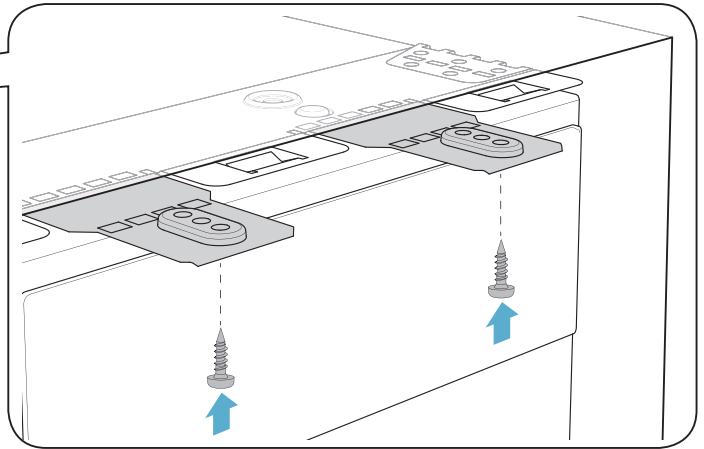

A
B
C
D

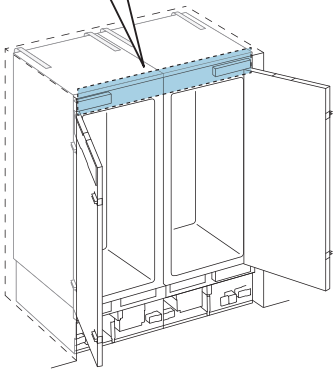
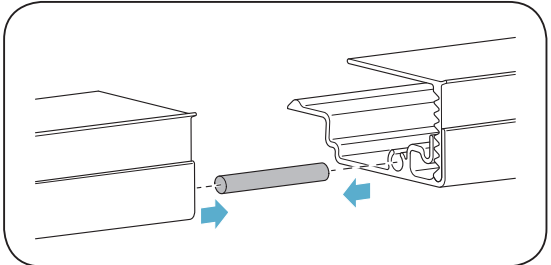
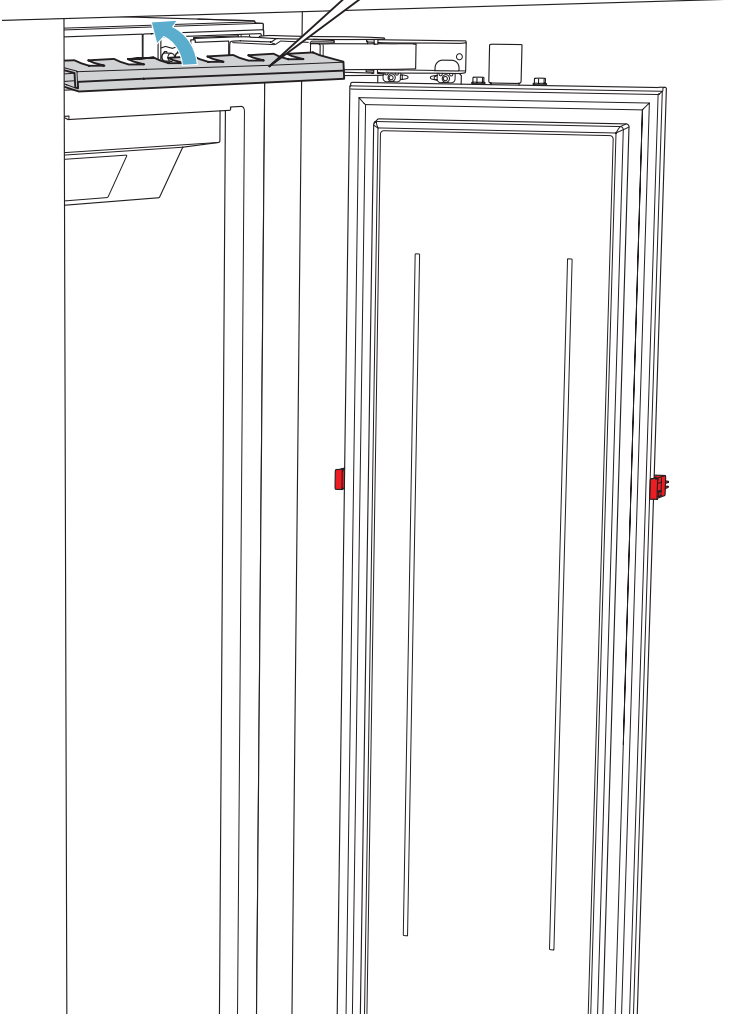
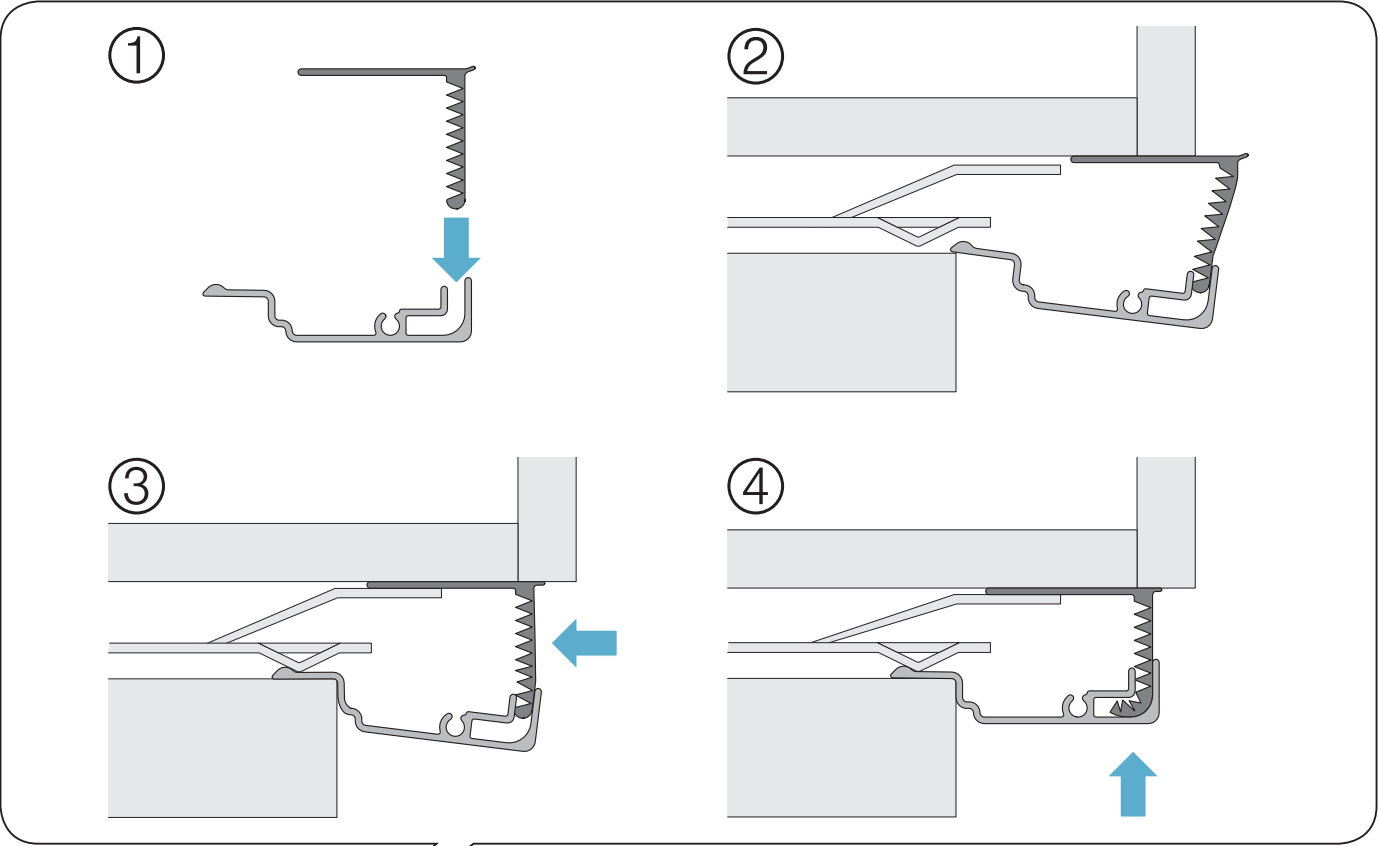

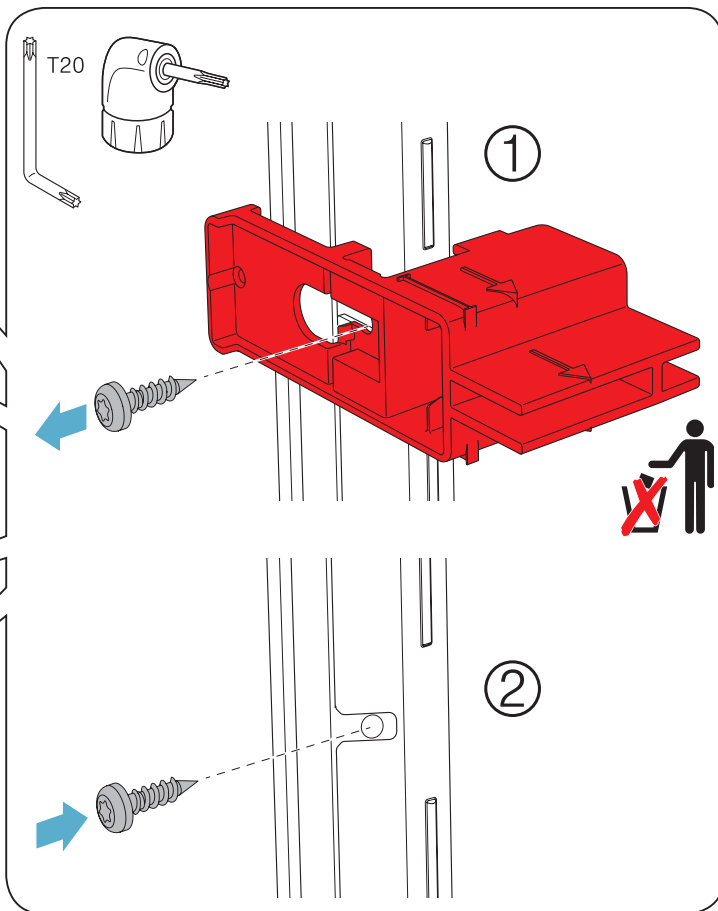
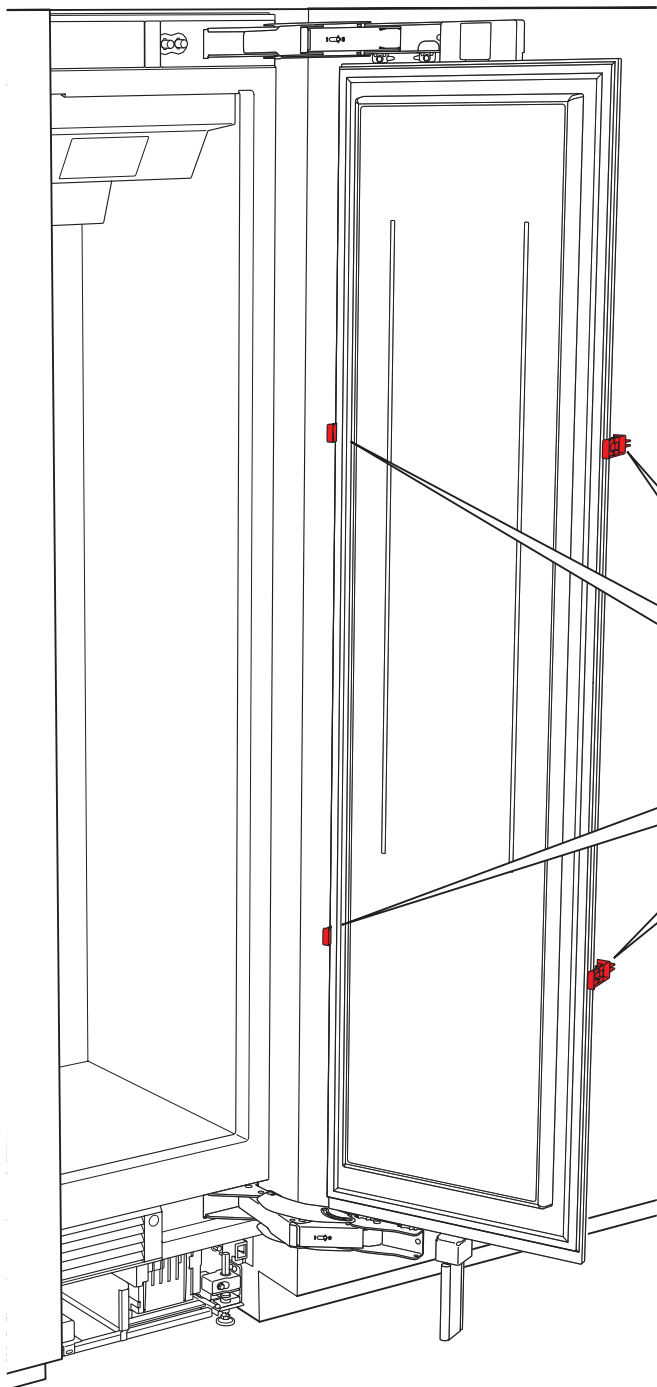

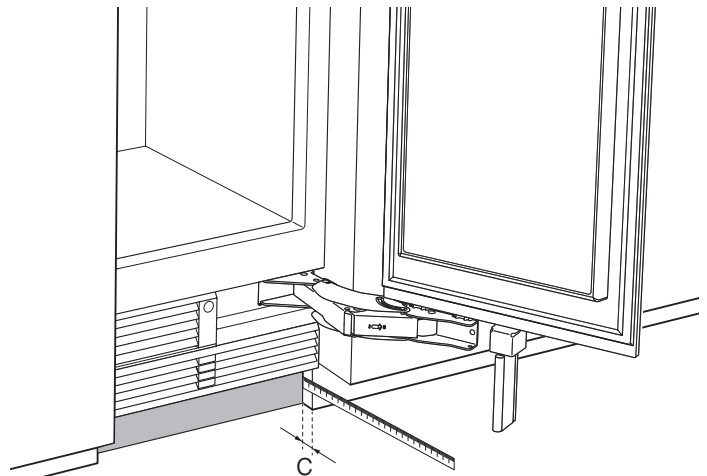
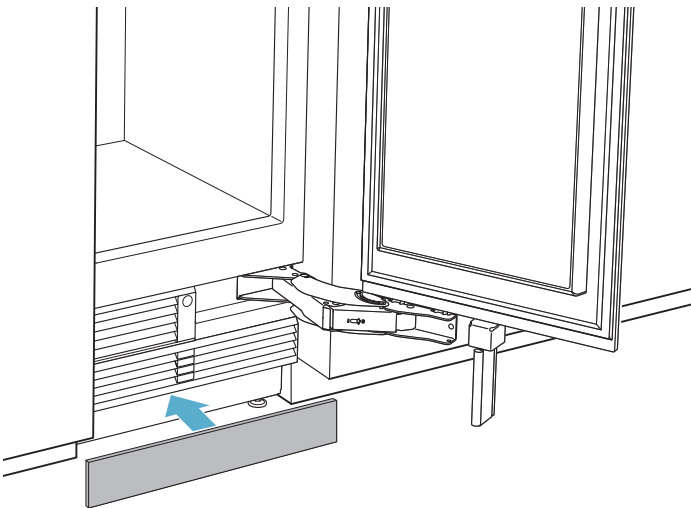
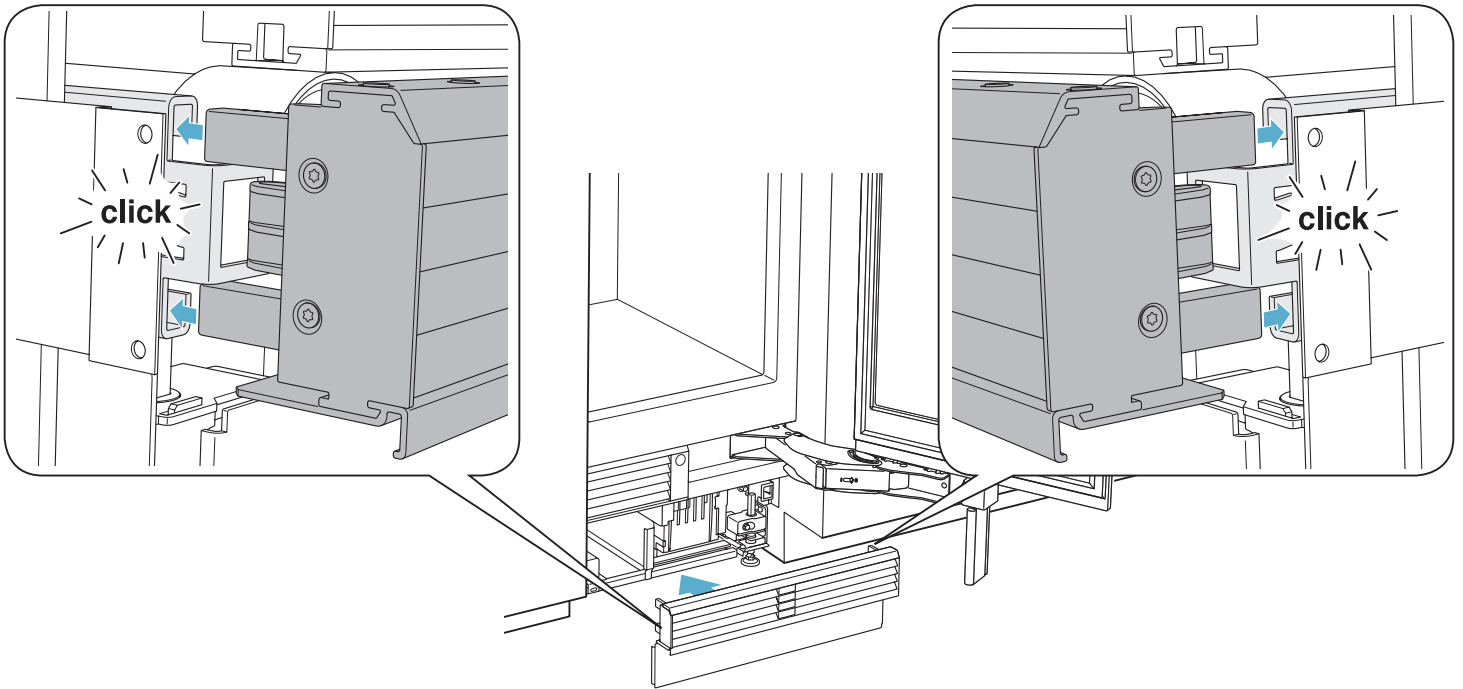
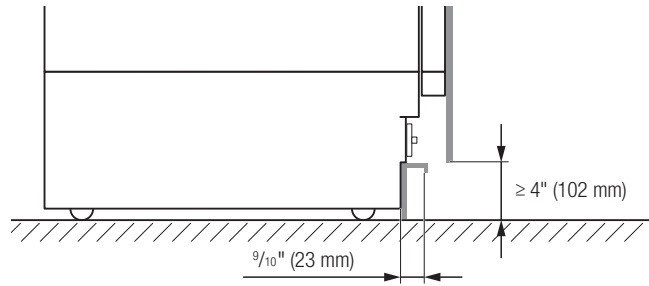
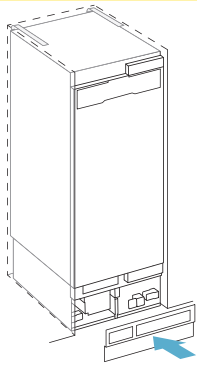

- A
- B
- C
- D

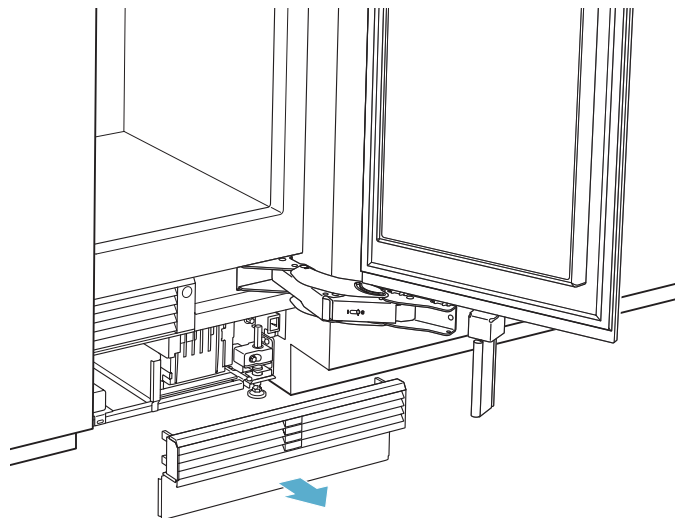
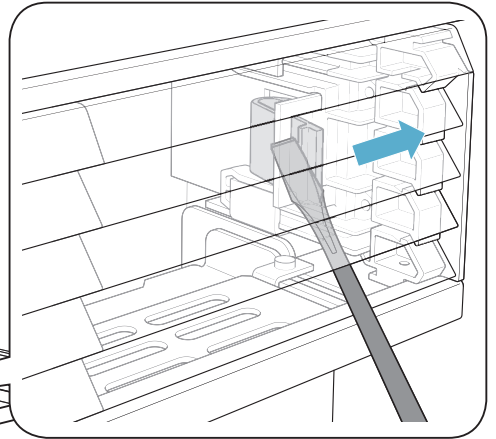
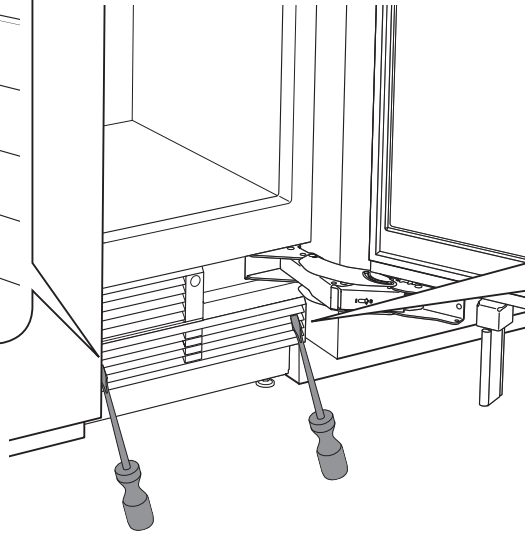
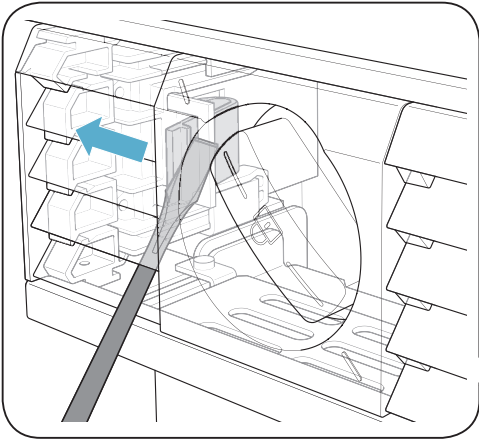
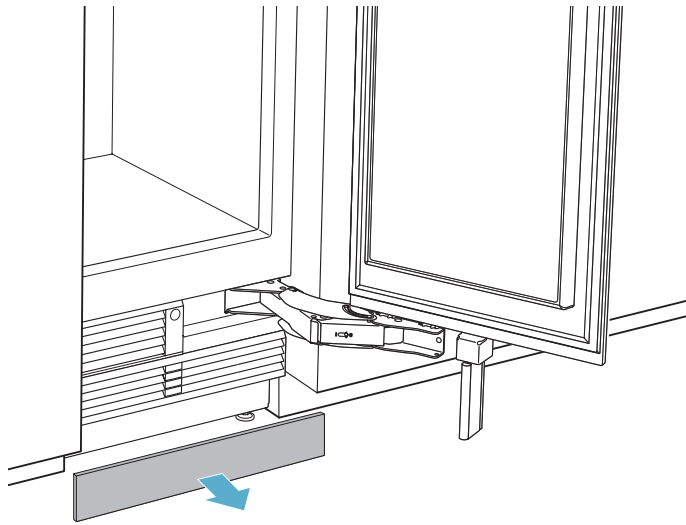

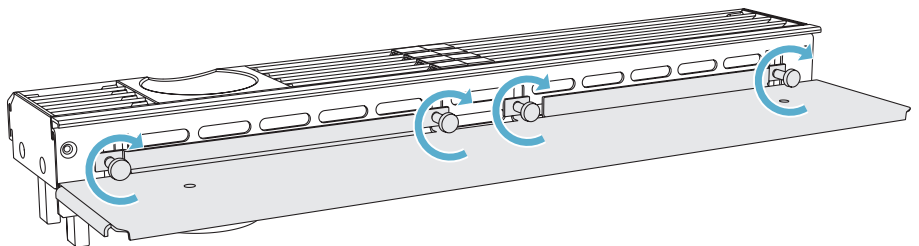
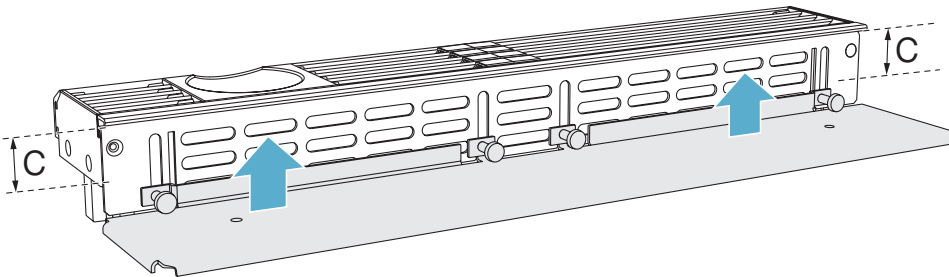
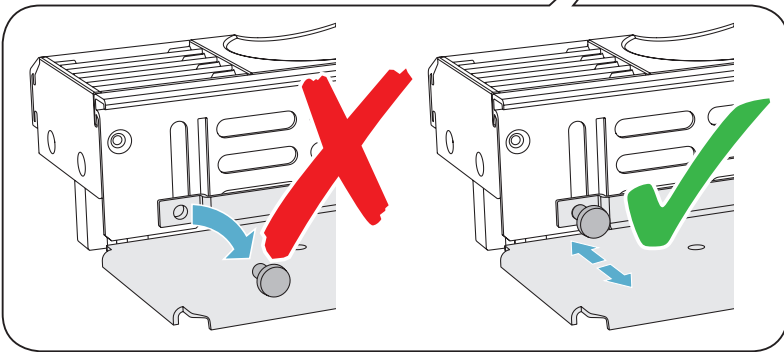
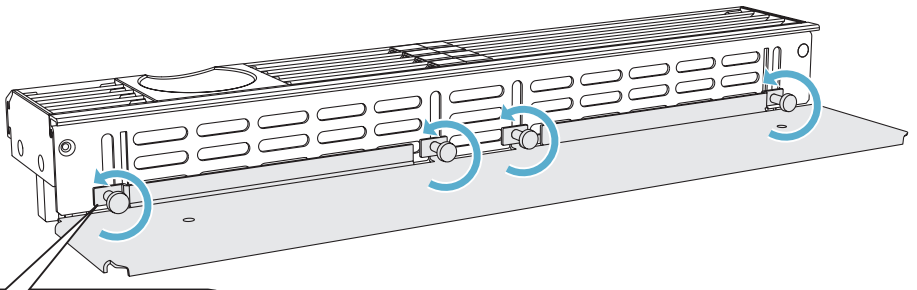
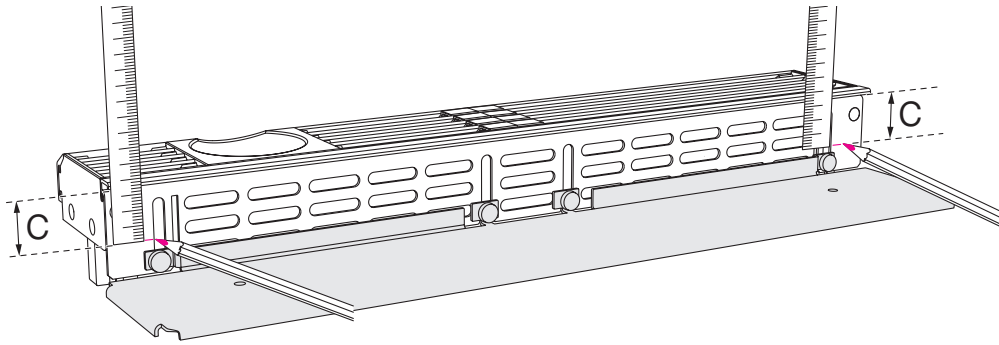

- A
- B
- C
- D

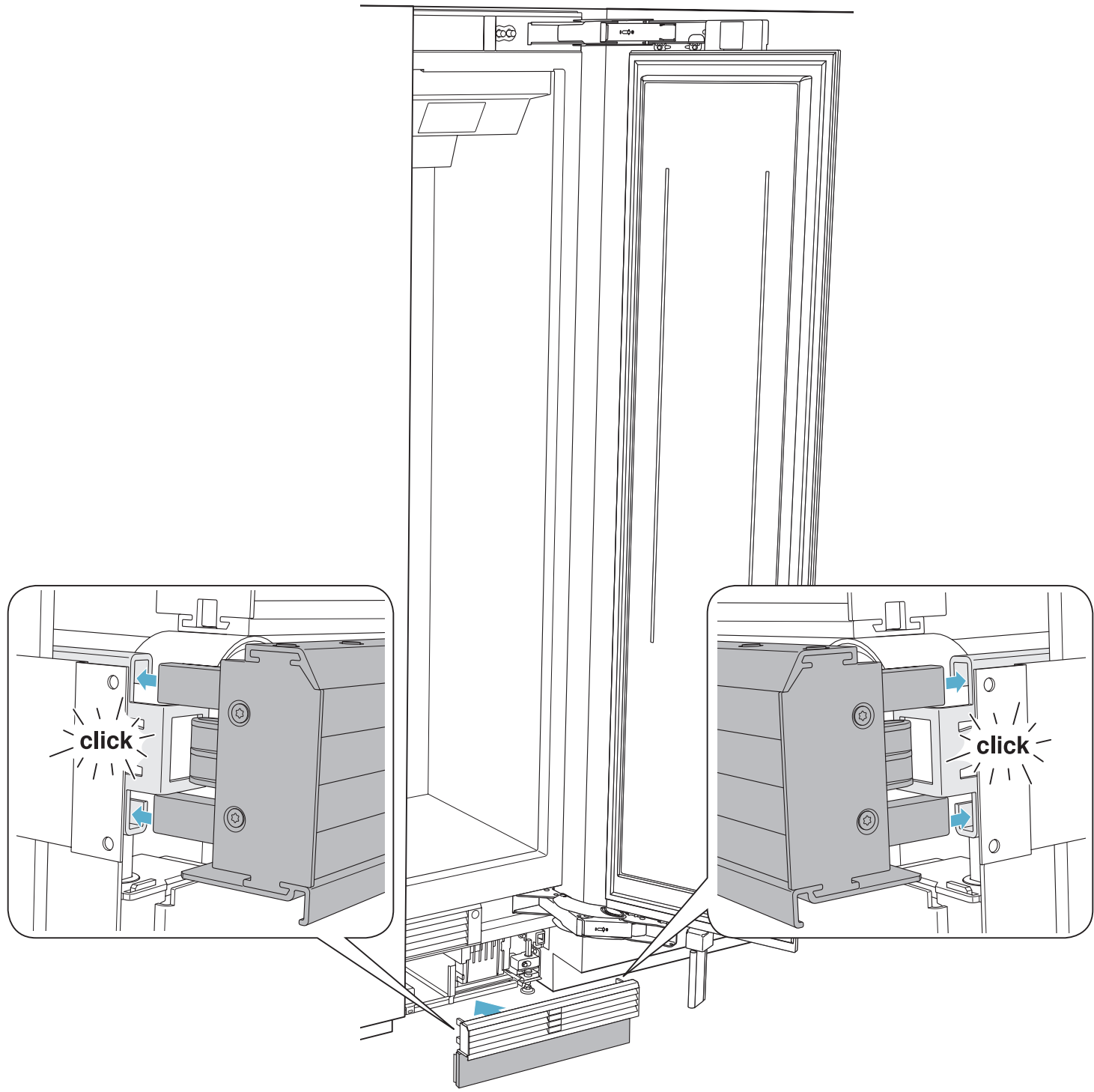
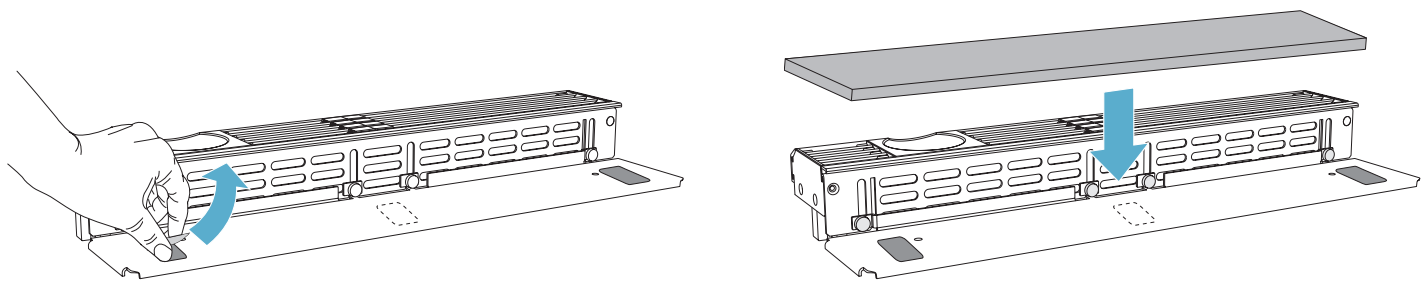

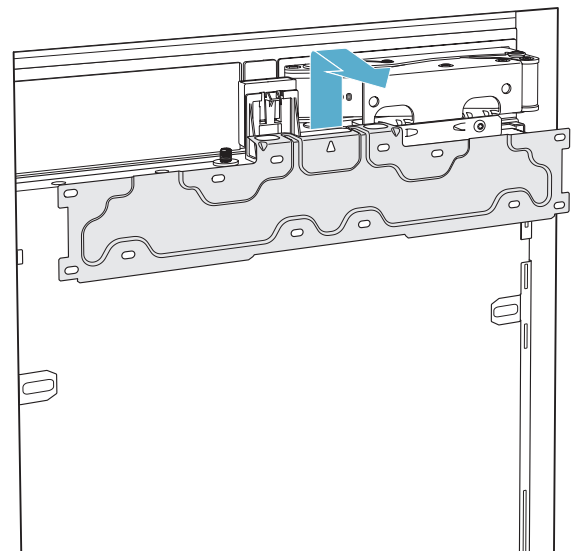
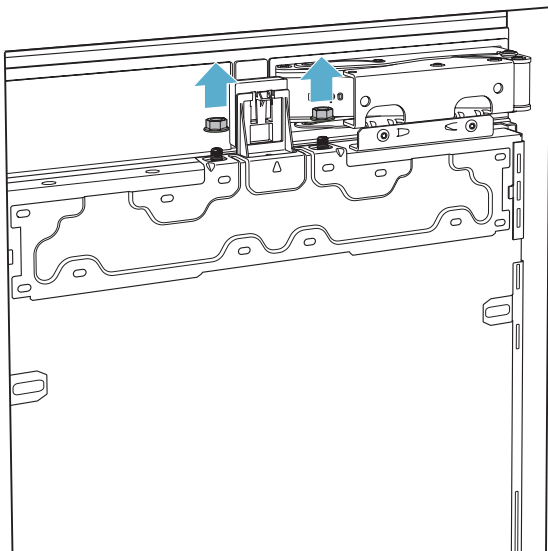
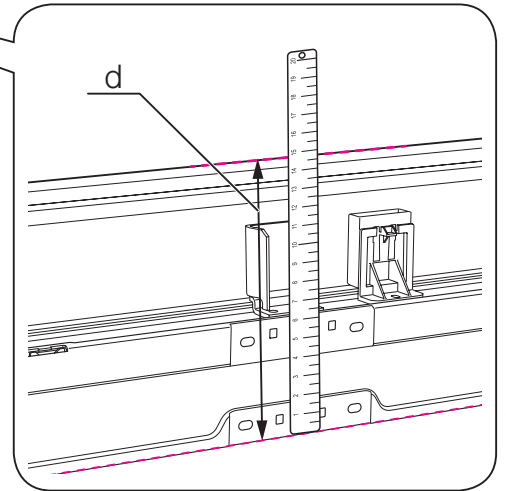
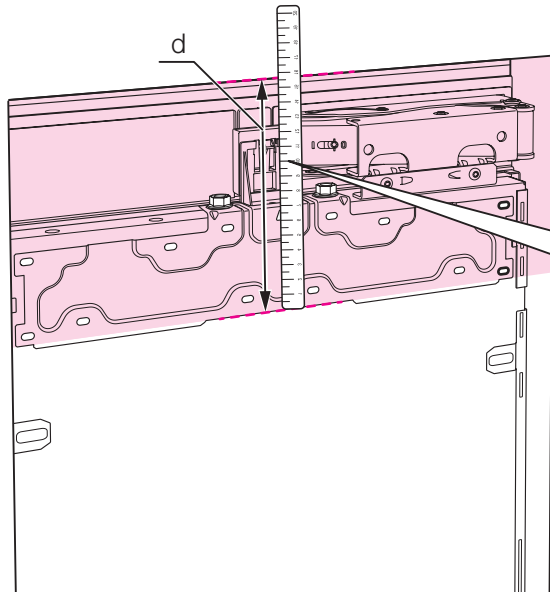
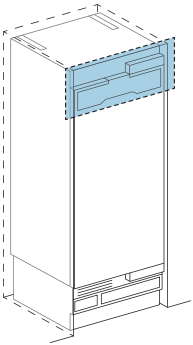
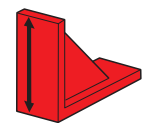
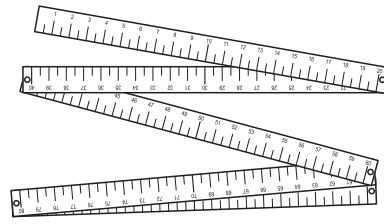
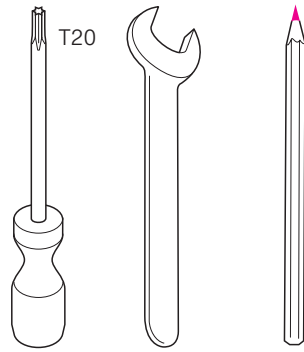
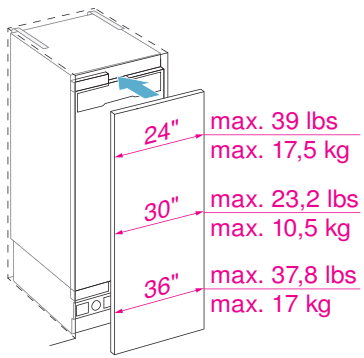

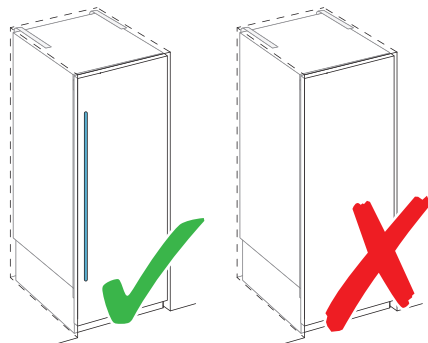
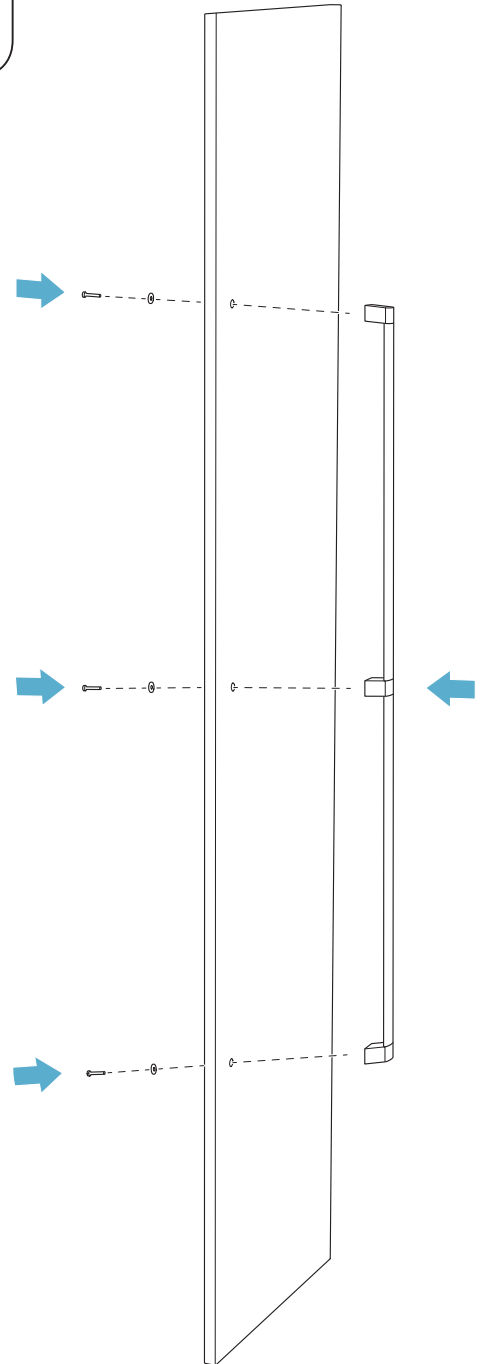
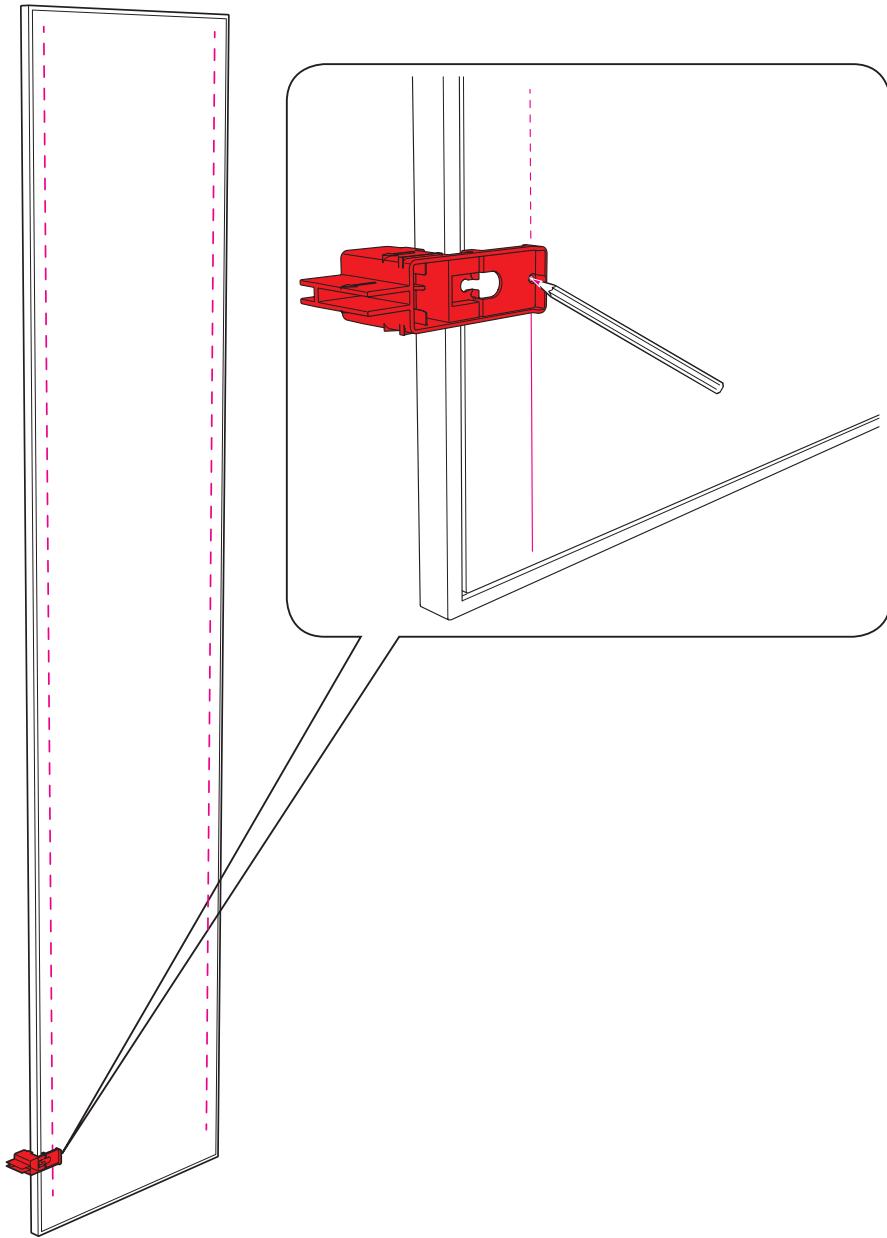

- A
- B
- C
- D

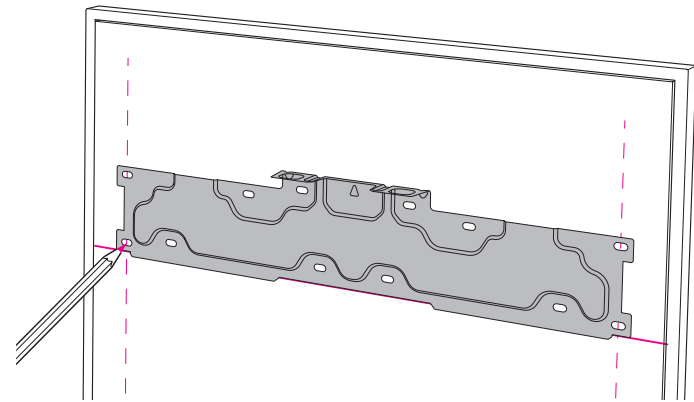
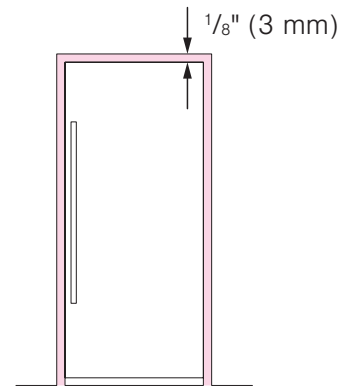
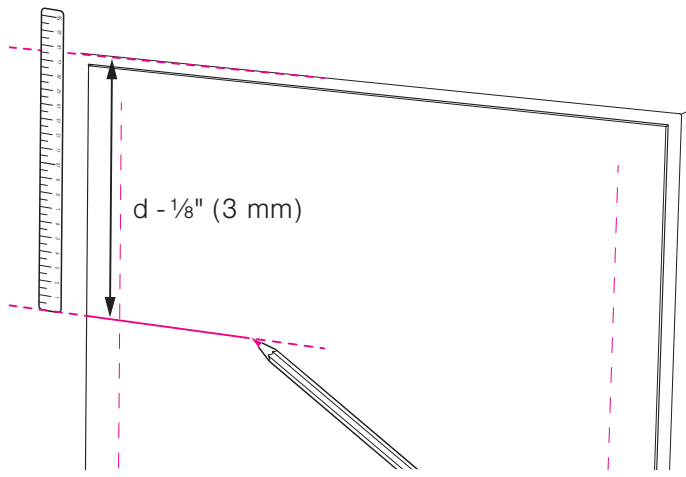



4x15			24" (610 mm) min. 6x
			30" (762 mm) min. 10x
			36" (915 mm) 12x

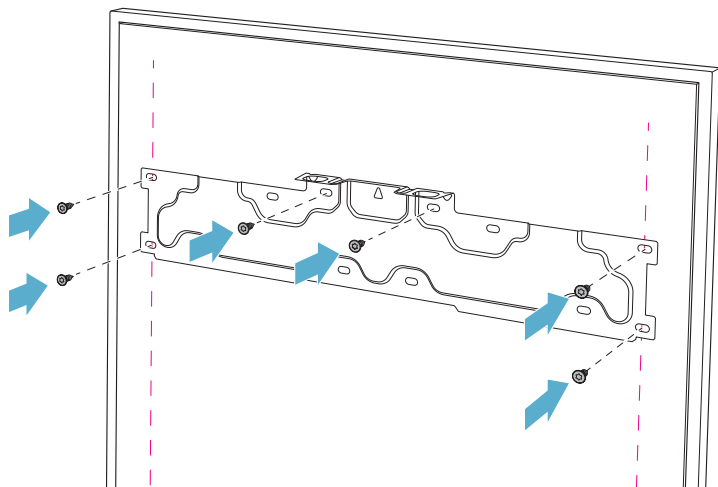

- A
- B
- C
- D

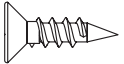
4x15   12x

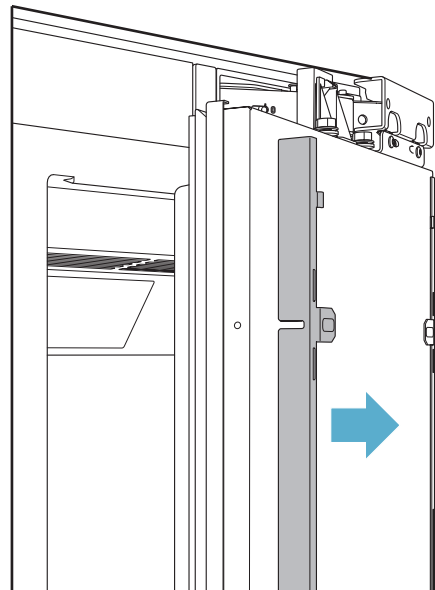
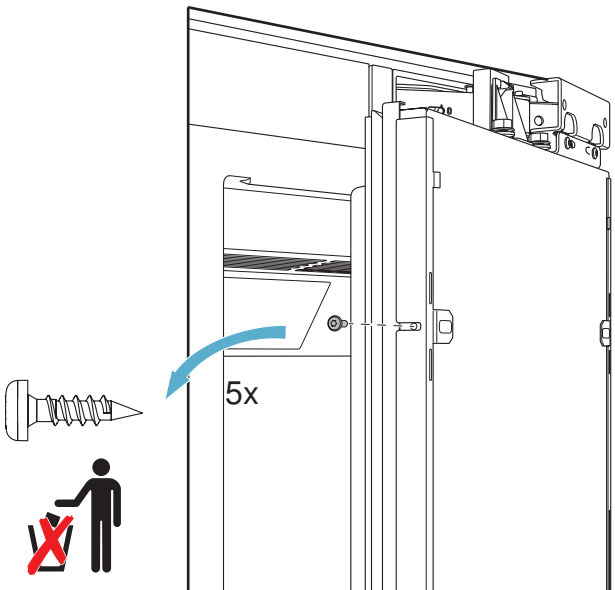
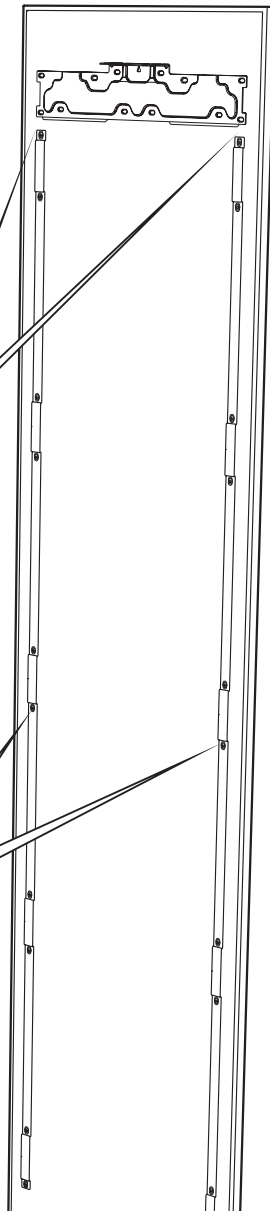
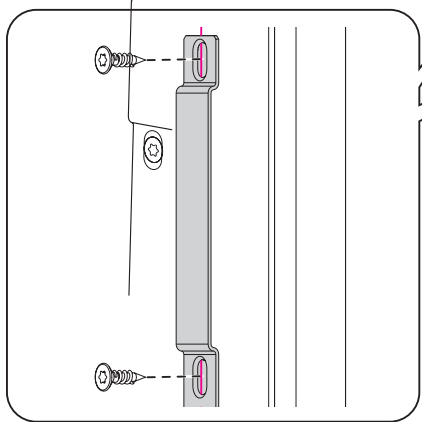
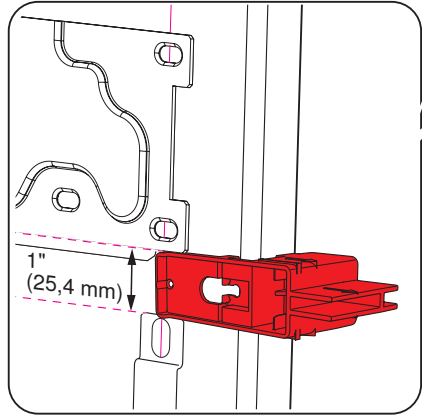

A

B

C

D

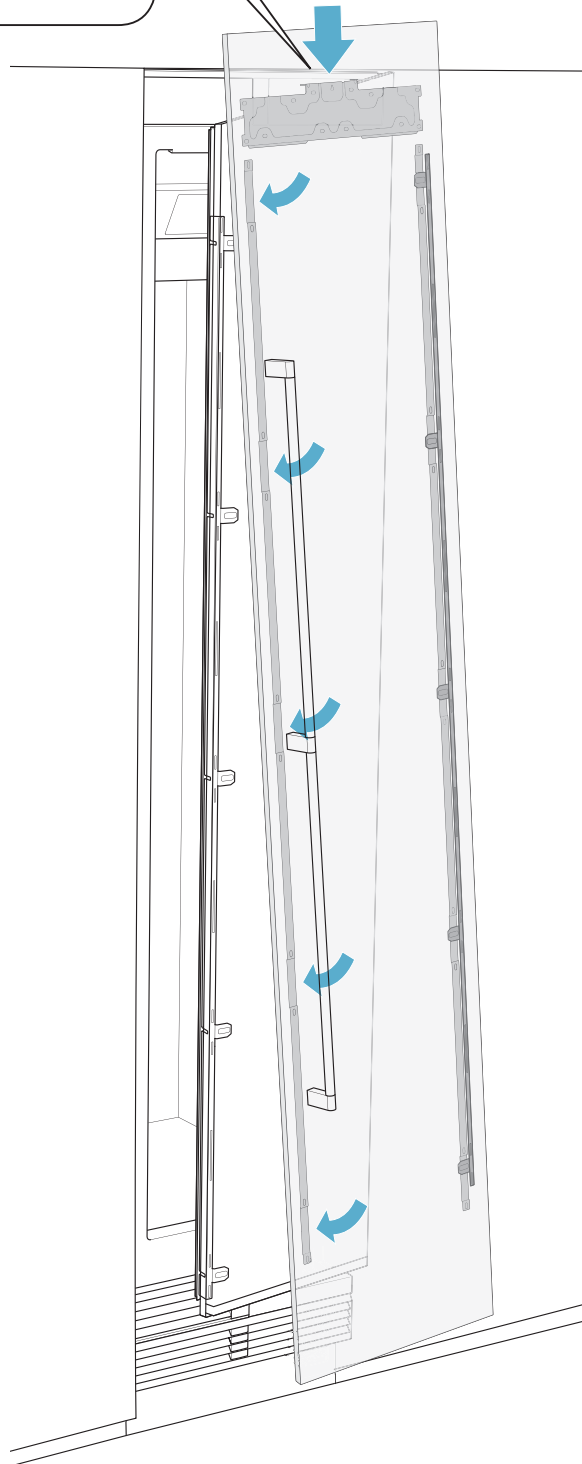
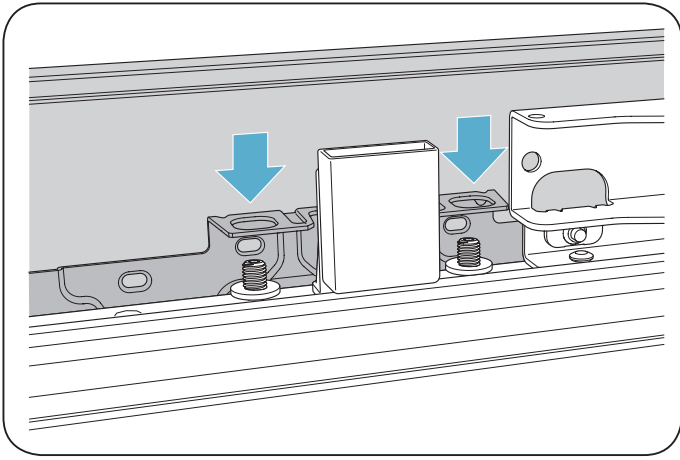

- A
- B
- C
- D

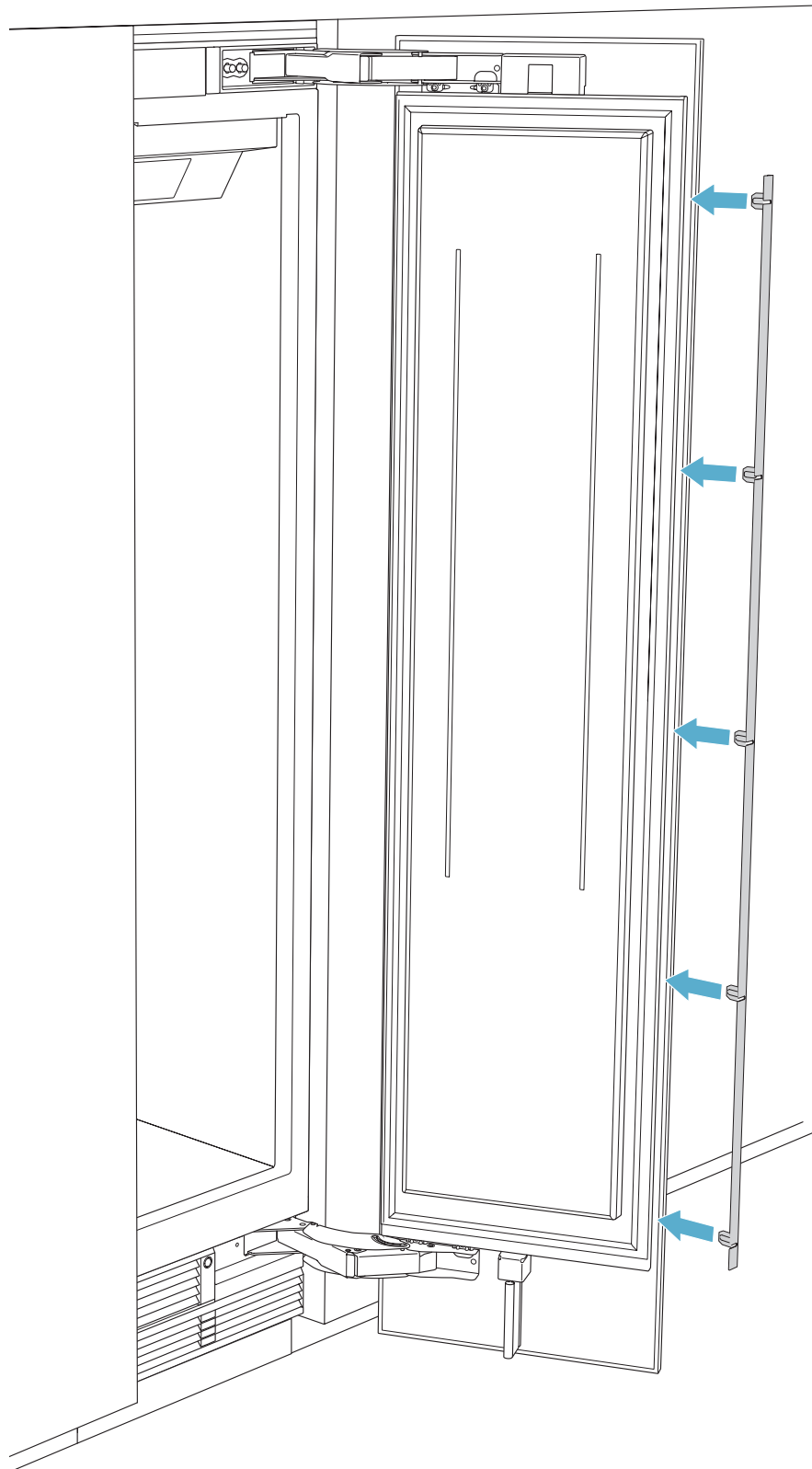

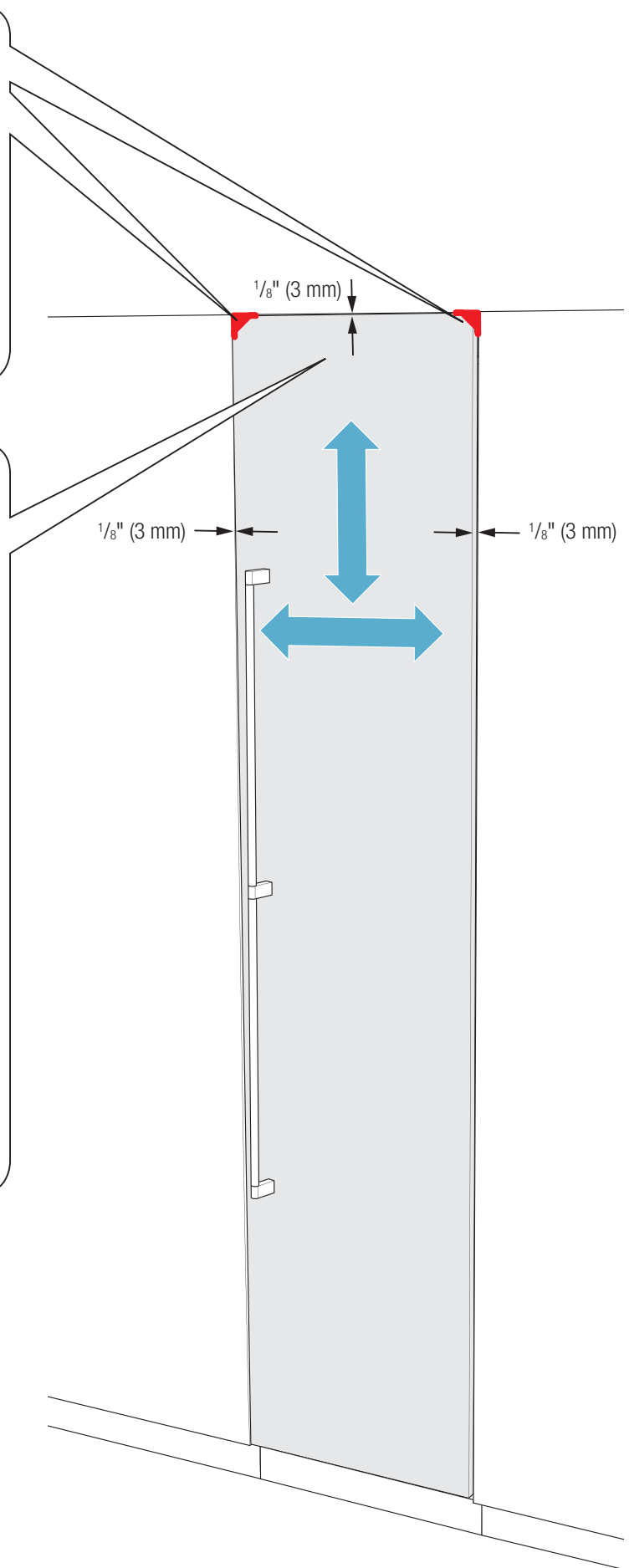
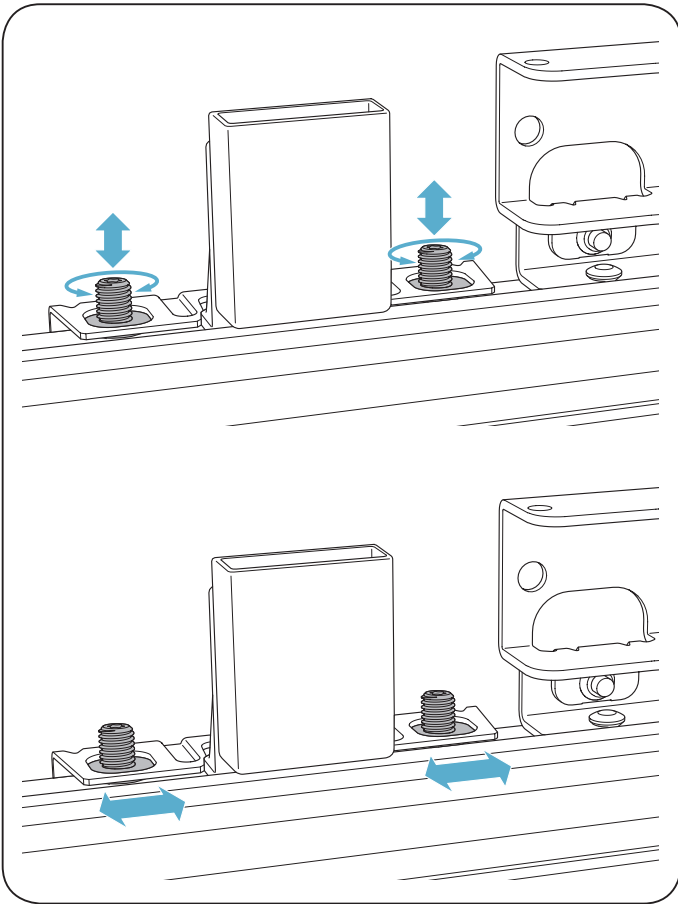
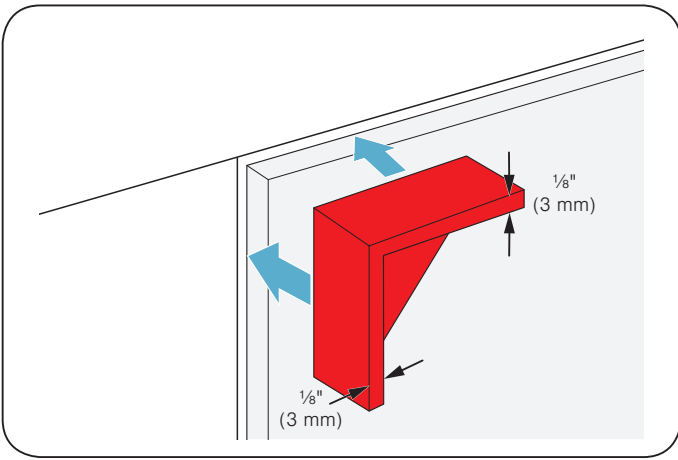

- A
- B
- C
- D

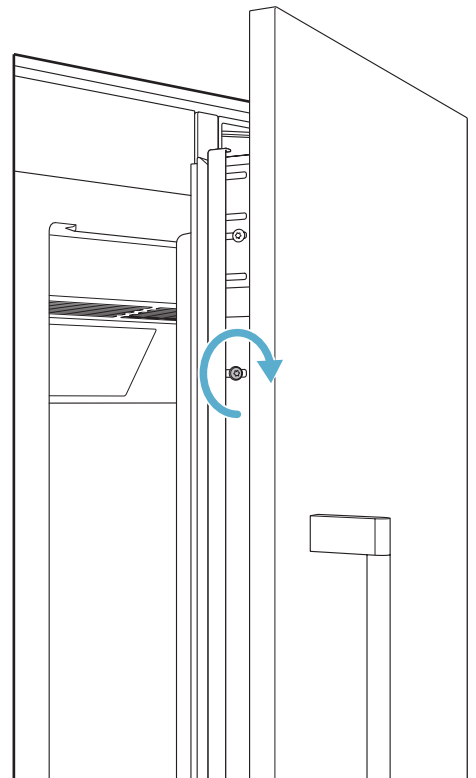
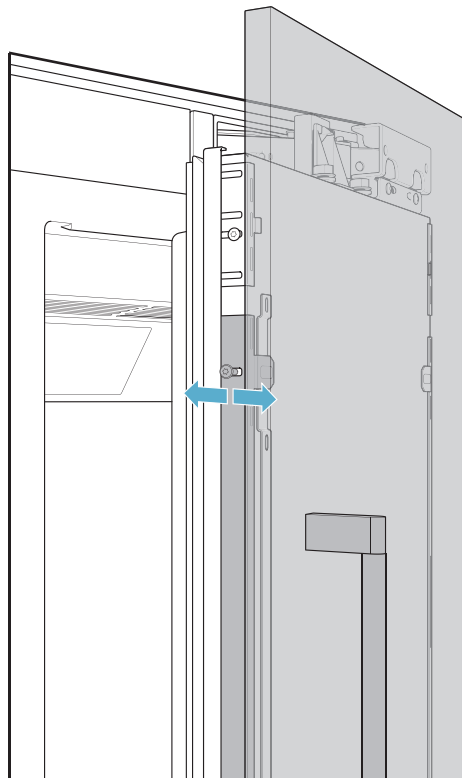
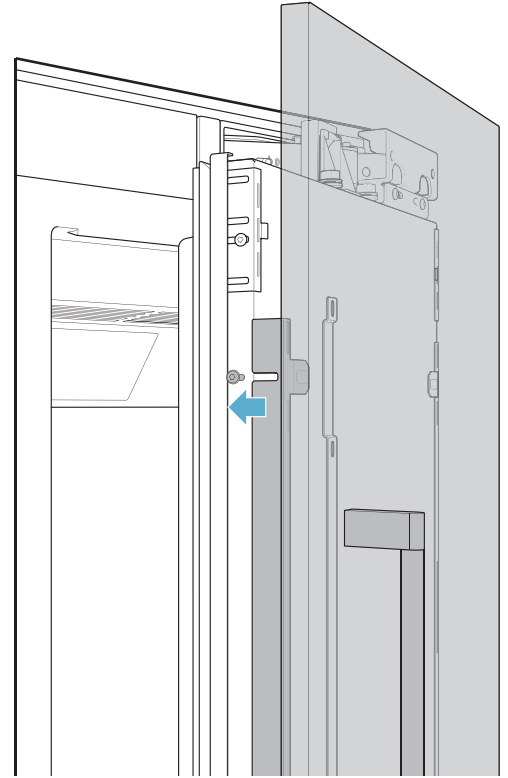
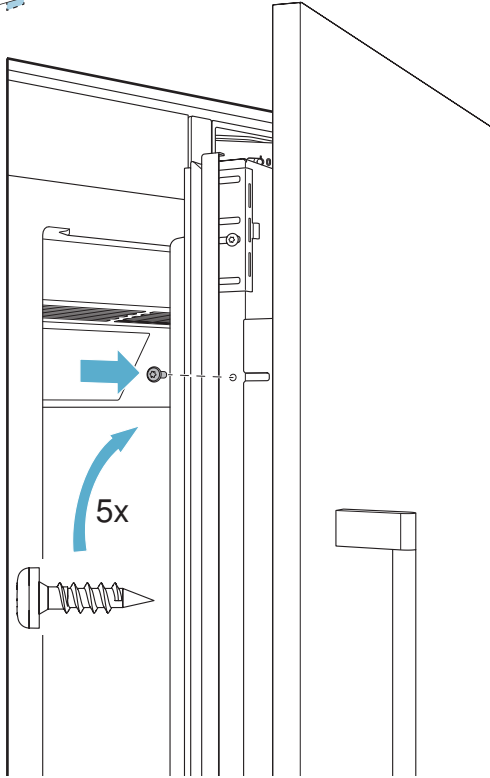
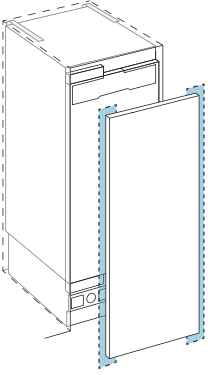

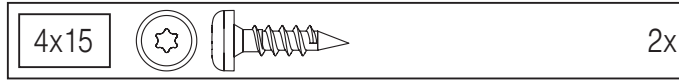
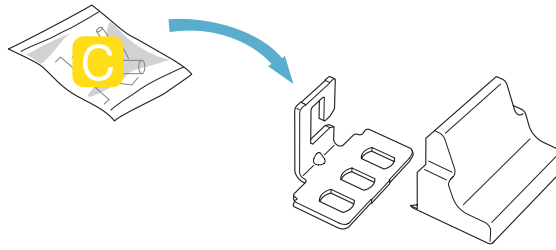
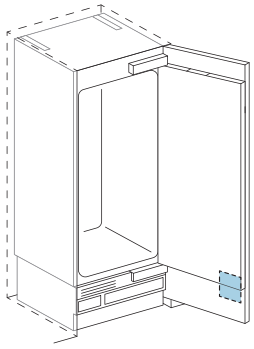

①

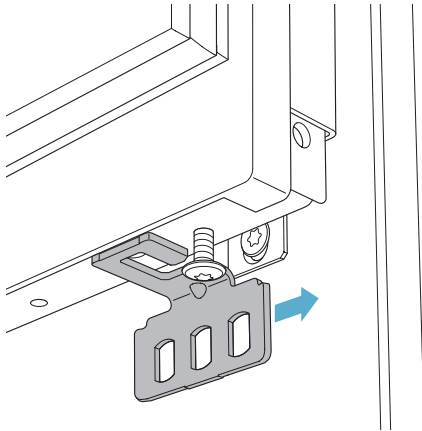

②

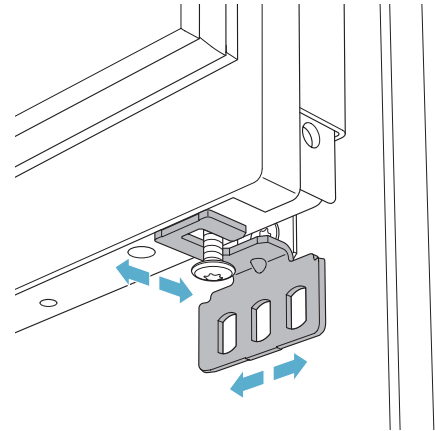

③

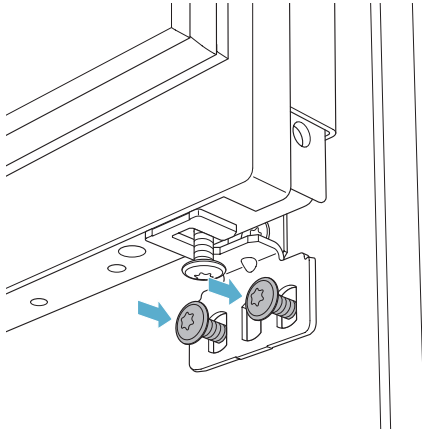

④

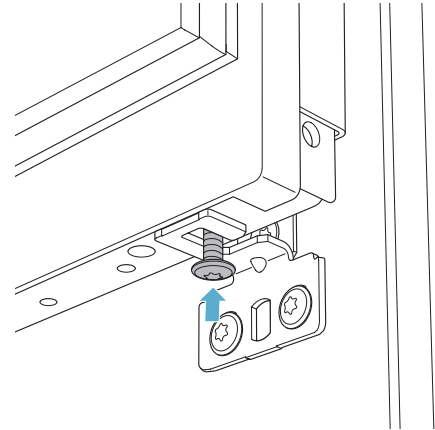

⑤

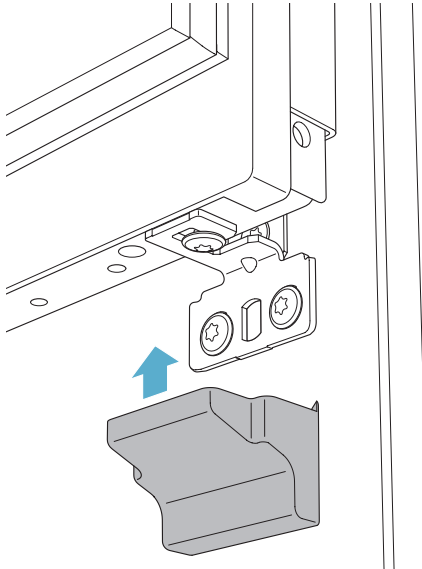

⑥

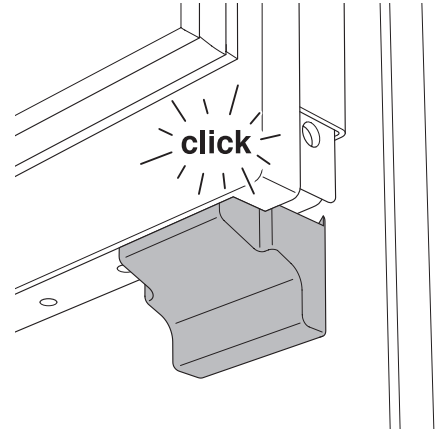

- A
- B
- C
- D

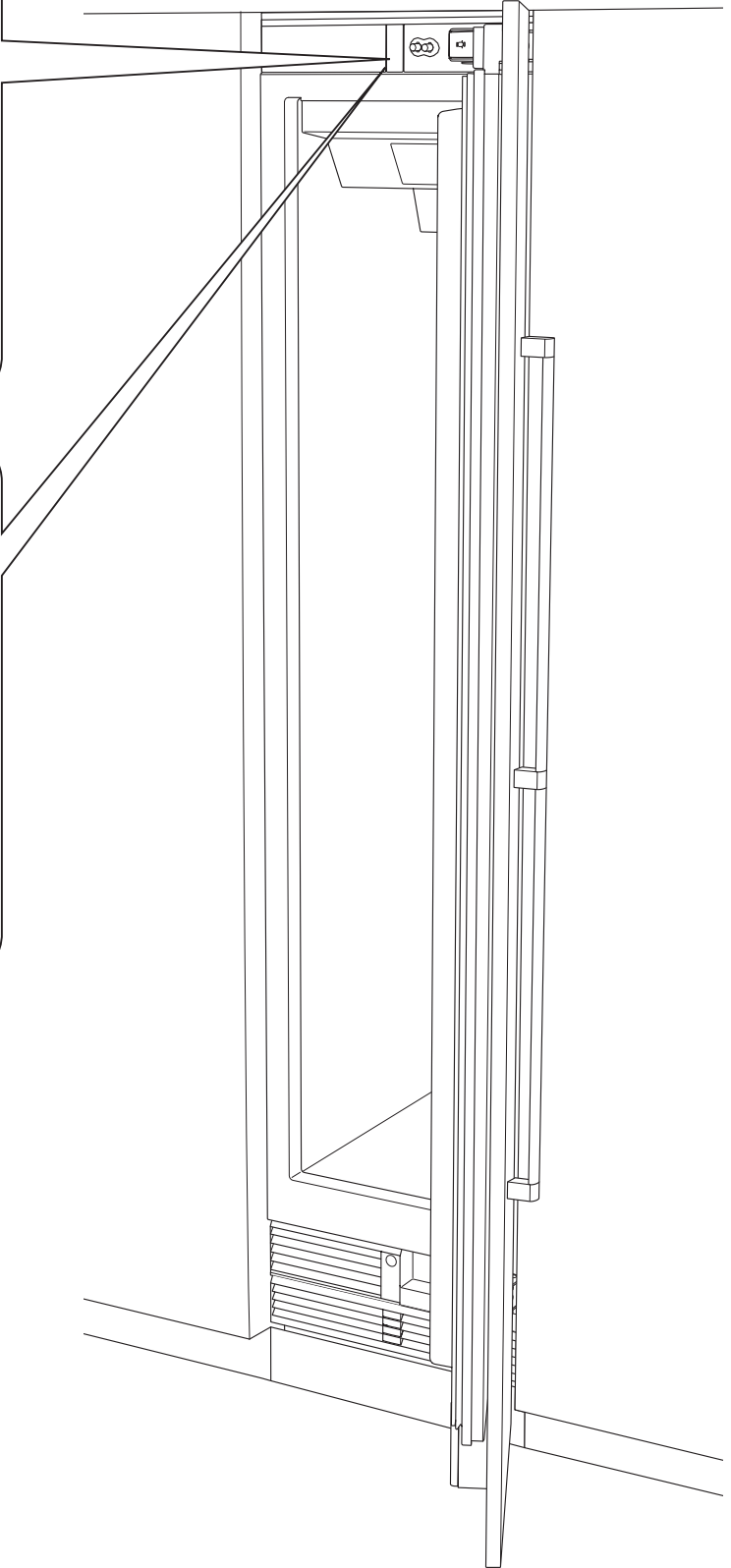
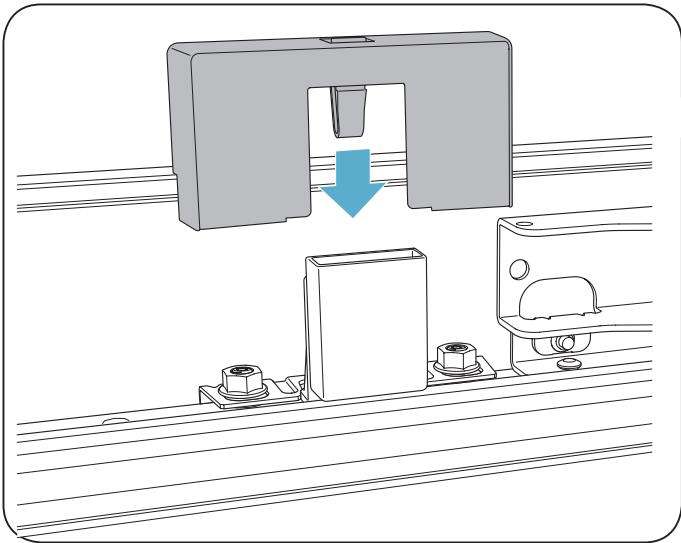
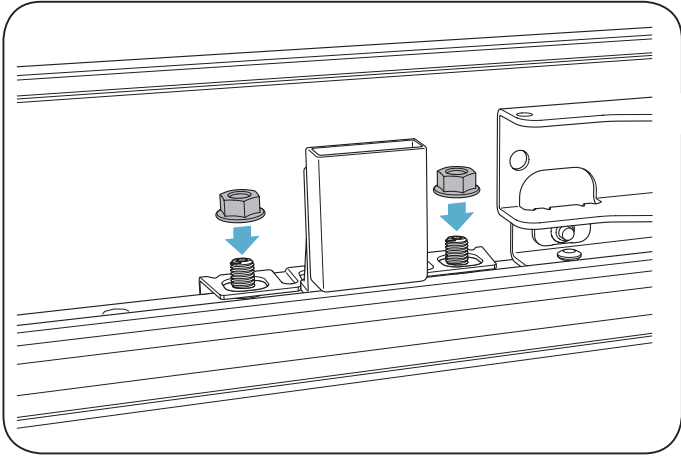

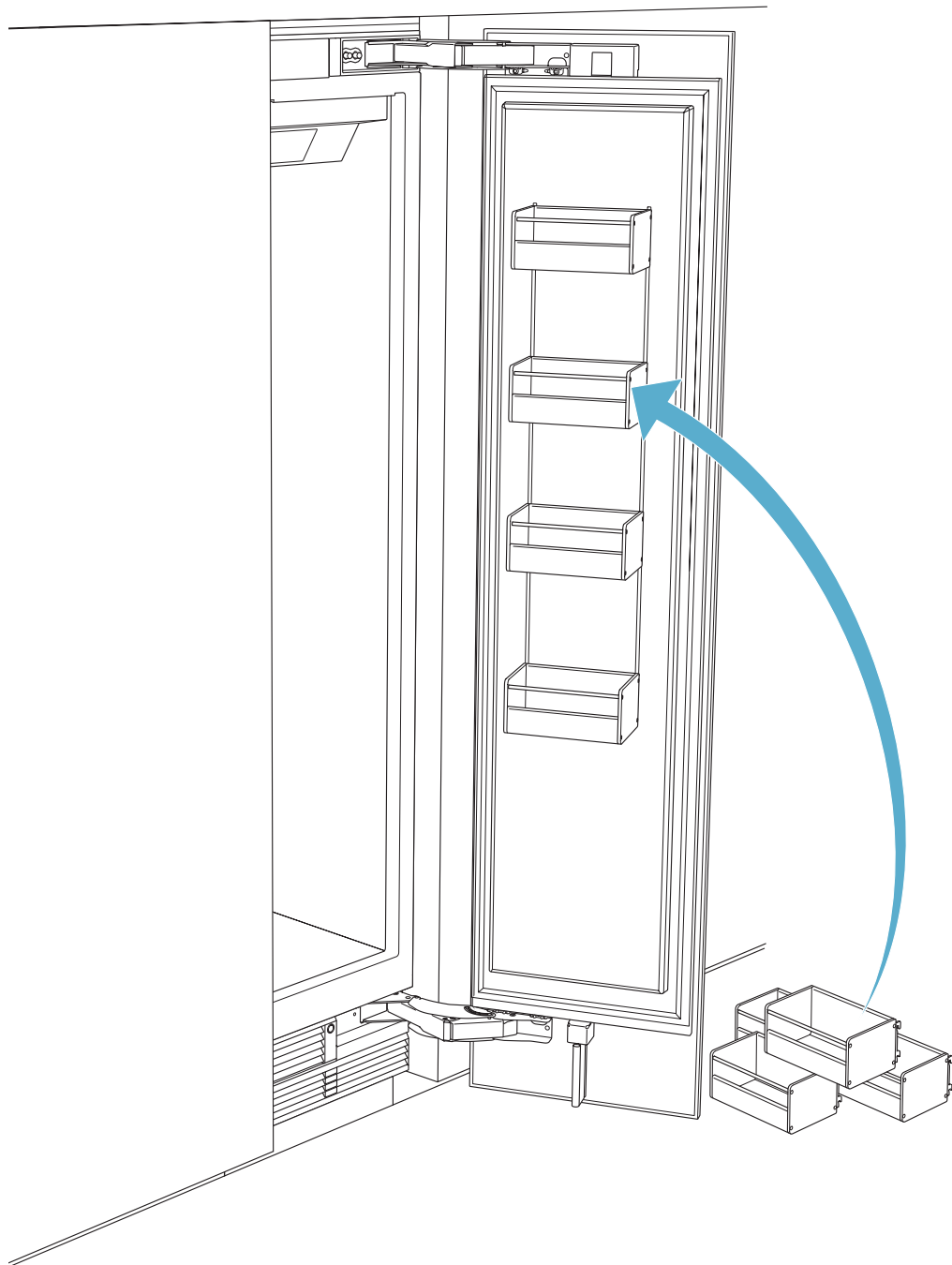

- A
- B
- C
- D

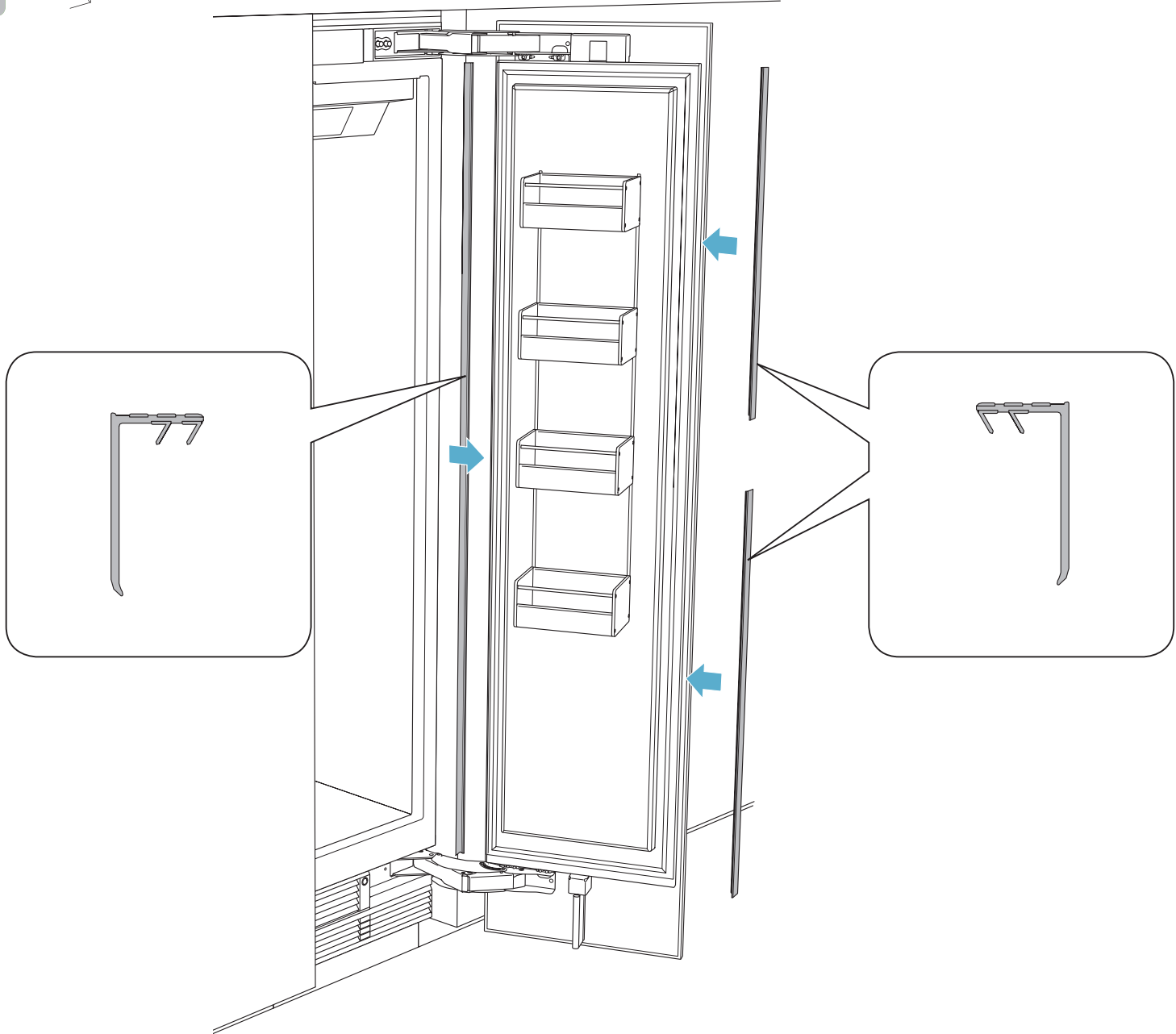
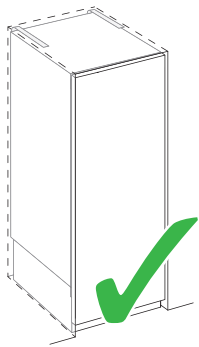

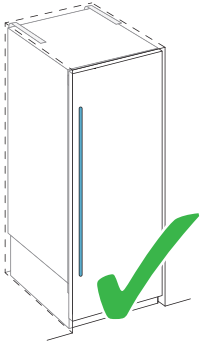

- A
- B
- C**
- D

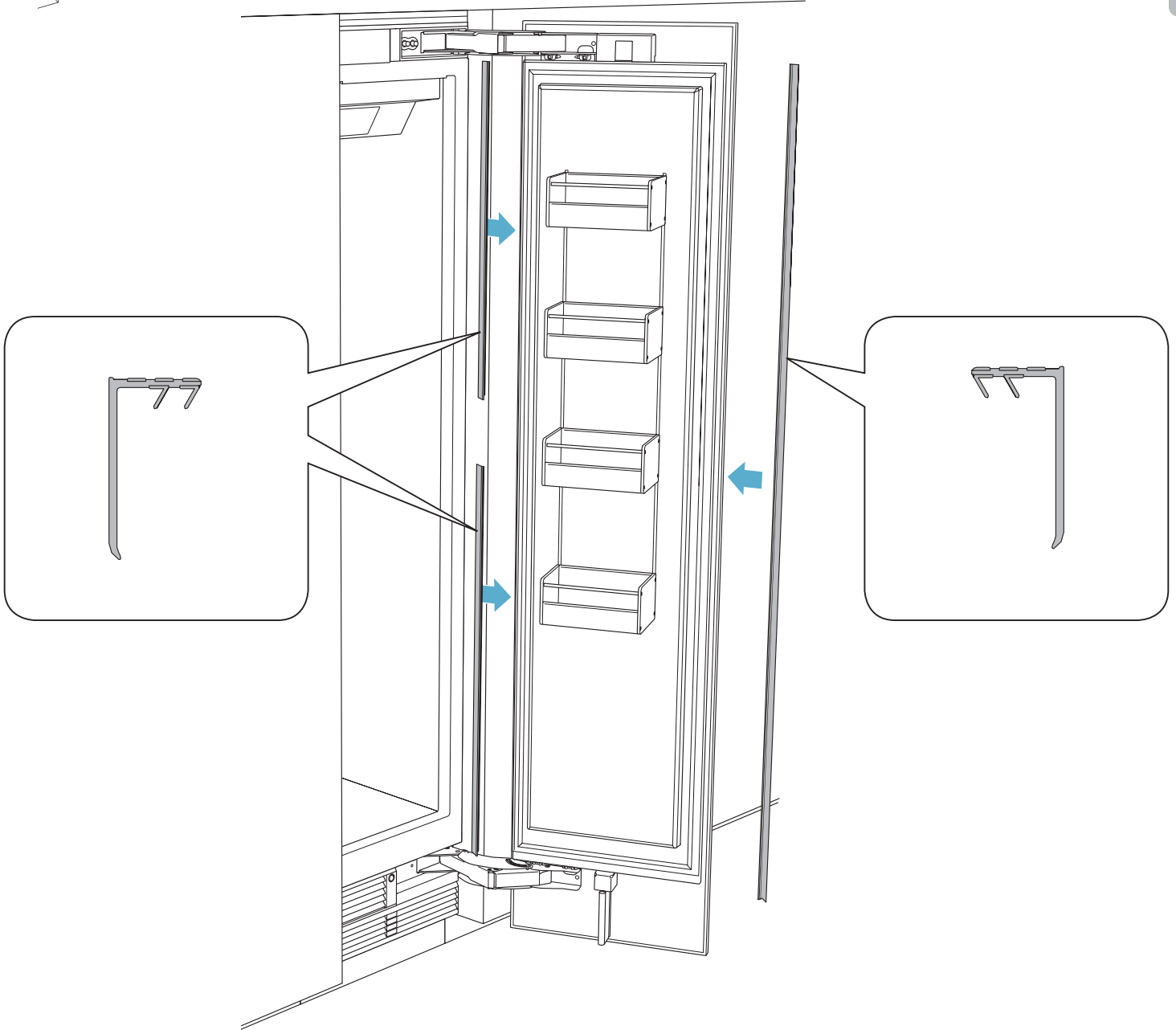

- A
- B
- C
- D

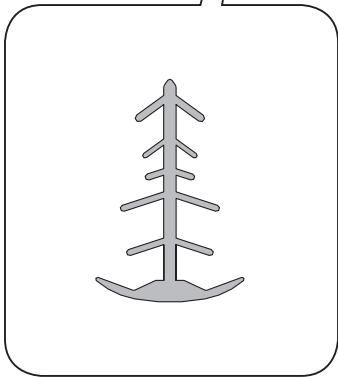
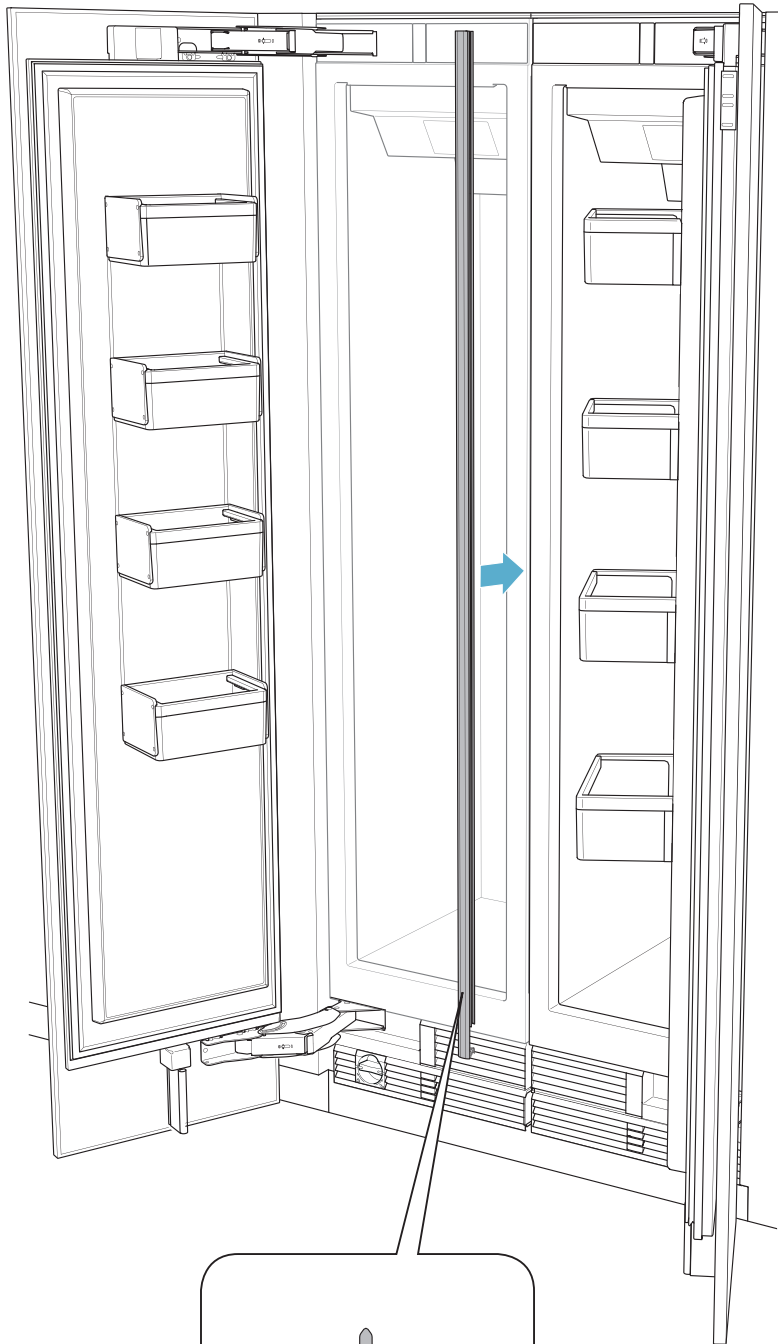

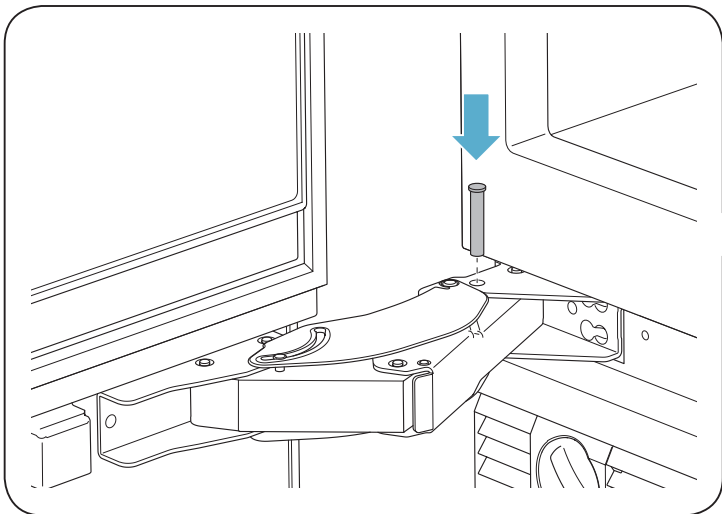
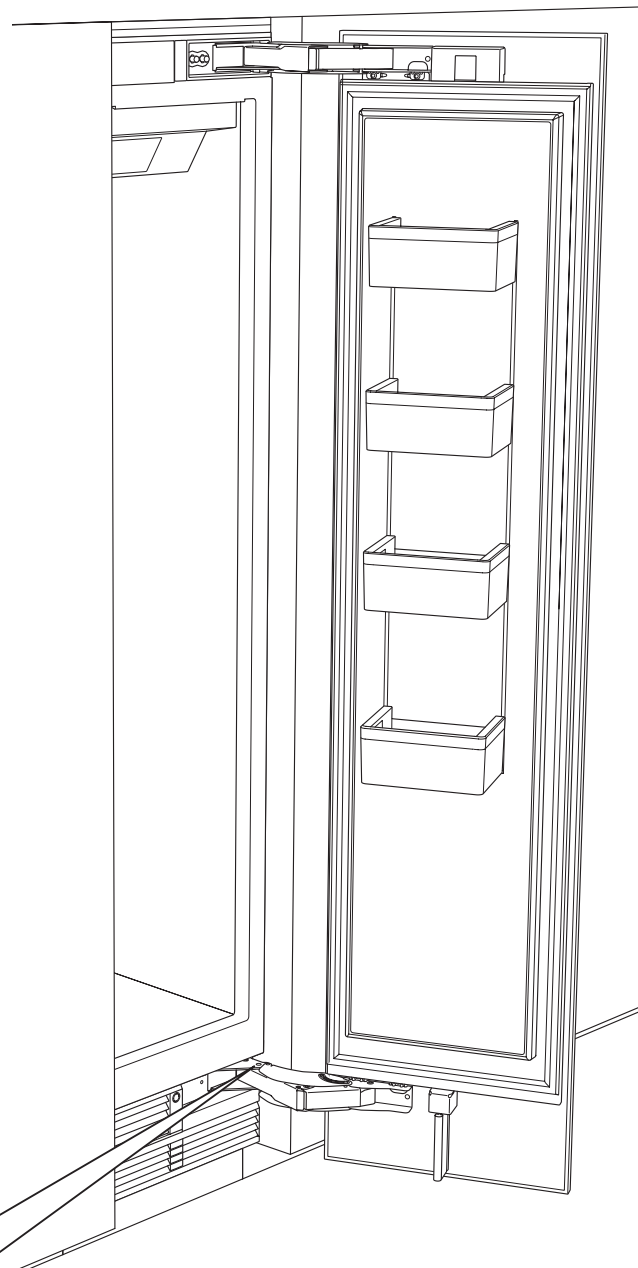
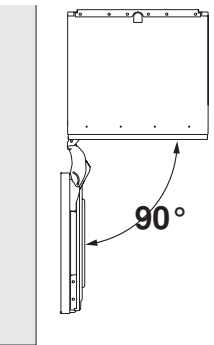
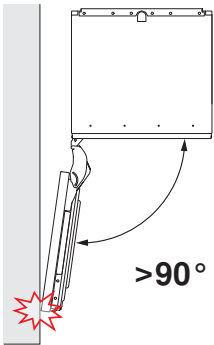
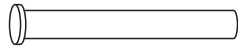

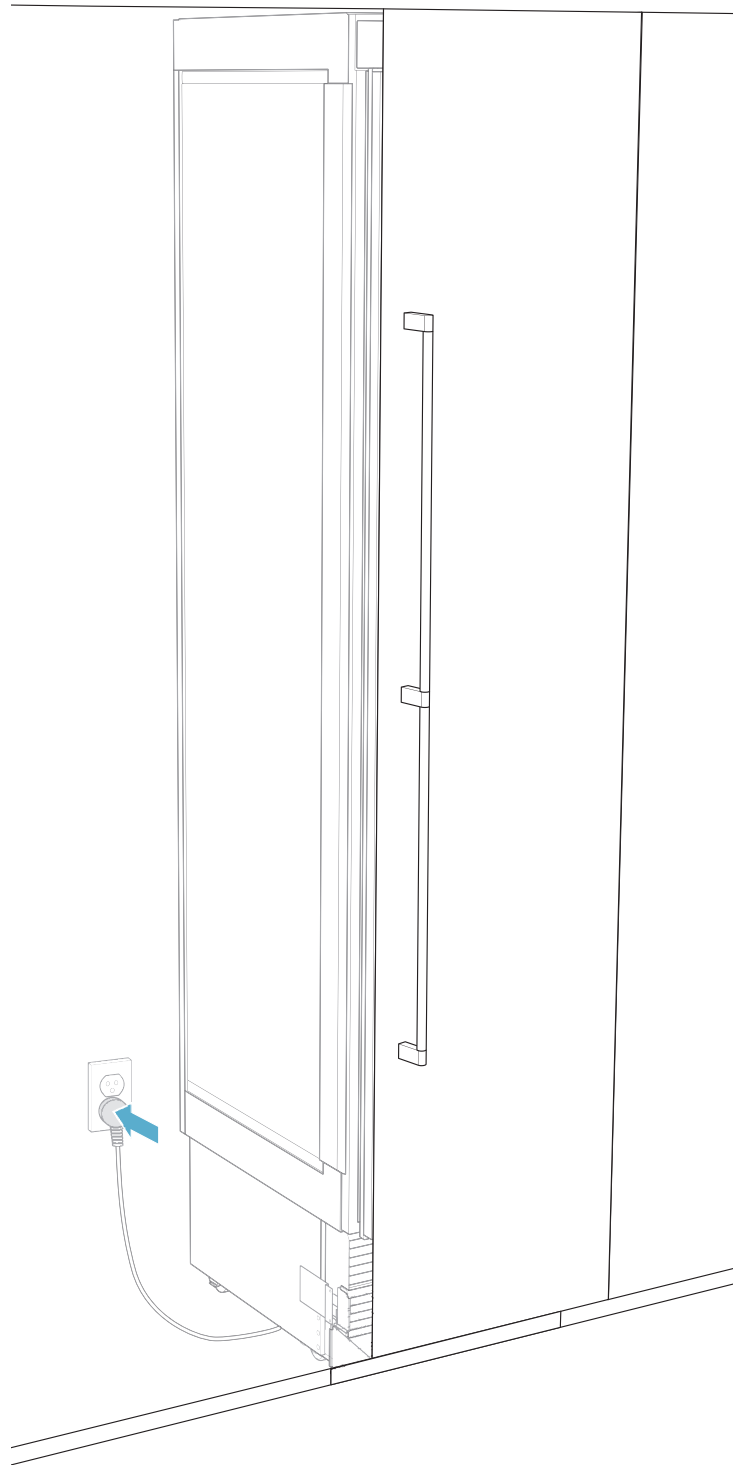

Gaggenau Hausgeräte GmbH
Carl-Wery-Straße 34
D-81739 München
www.gaggenau.com

Subject to alterations.
Sous réserve de modifications.
Se reserva el derecho a efectuar modificaciones.

GAGGENAU

8001170416 (9909)
en-us, fr-ca, es-mx