



SPEED QUEEN® MULTI-HOUSING LAUNDRY SOLUTIONS
Front Control Front Load Washer

Quantum® Gold Pro

Prep for Card | Coin Drop Installed

Built for Reliable Performance

Engineered and built like no other, the Speed Queen® front load washer is designed to be everything people thought a washer couldn't be, beginning with its revolutionary suspension and sensing technology. This groundbreaking innovation manages and redistributes out-of-balance loads to deliver uninterrupted cycles, virtually eliminate vibration and operate so quietly neighboring residents won't even know it's running. It also touts an incredible 440 G-Force extraction speed to maximize moisture removal, reduce dry times and minimize utility costs. And as if that's not game-changing enough, this smooth-running, laundry-optimizing machine delivers increased water efficiency. It's everything you never knew it could be. Front controlled products have met every design standard to be 100% ADA compliant.

- Revolutionary balancing technology
- Industry leading 1200 RPM spin speed exerts 440 G-force extraction
- Integrated meter case
- Extra-wide 15.5" door opening and 180° door swing
- Rugged suspension system
- Easy-to-read digital display
- Large capacity meter case standard
- Multi-level vend pricing
- Individual cycle modifier keys
- Durable stainless steel tub standard
- Four-compartment soap dispenser
- Wash Alert™ capability



Quantum® Gold Pro Control

The Quantum® Gold Pro control delivers a truly premium experience to residents. From intuitive soft touch buttons that walk them through cycle options to multiple actuations (coin, card, mobile) for payment flexibility, this control gives residents the wash and dry options they want, and the revenue potential managers desire.

Front Control Front Load Washer

Quantum® Gold Pro

Specifications		
Control Option	Quantum Gold Pro	
Color	White	
Capacity - lb (kg)	21.5 (9.5)	
Overall Width - in (mm)	26.875 (683)	
Overall Depth - in (mm)	27.73 (704)	
Overall Height - in (mm)	44.34 (1126)	
Cylinder Volume - cu. ft. (liters)	3.42 (96.8)	
Spin Speed G-Force (RPM)	440 (1200)	
Motor Size - HP (kw)	0.9 (0.67)	
Water Consumption Per Cycle - g (liter)**	13.68 (51.8)	
IWF (Water Factor) - gal/ft ³ (liters/liter/cycle)**	4.0 (0.53)	
MEF _{j2} (Modified Energy Factor) ft ³ /kWh/cycle (Liters/kWh/cycle)**	2.20 (62.3)	
Available Water Temperatures	Hot, Warm, Cold	
Available Cycles	Normal, Perm Press, Delicates/Bulky	
Electrical Requirements (v/Hz/Ph-Amp)	120/60/1 - 15 Amp	
Water Pressure - p.s.i. (bar)	20-120 (1.4/8.3)	
Cylinder Finish	Stainless Steel	
Net Weight - lb (kg)	260 (118)	
Shipping Weight - lb (kg)	270 (122.5)	
Shipping Dimensions Approx. - in (mm)	Width	34 (864)
	Depth	30 (762)
	Height	44.5 (1130)
Agency Approvals	cULus	

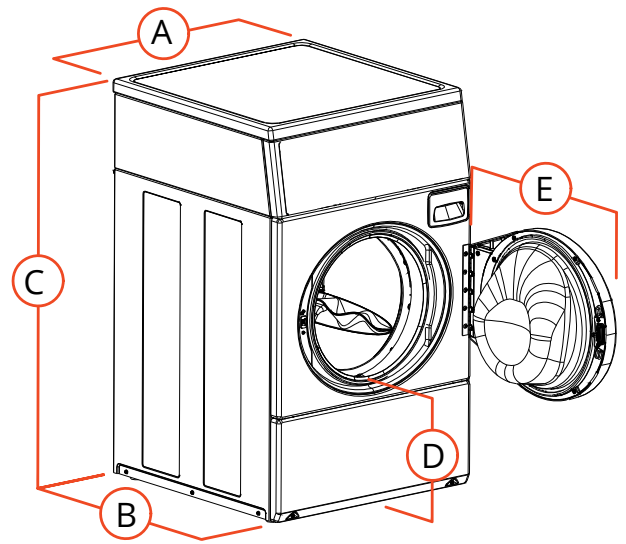

A. Overall Width - in (mm)	26.875 (683)
B. Overall Depth - in (mm)	27.73 (704)
C. Overall Height - in (mm)	44.34 (1126)
D. Floor To Door Opening -in (mm)	14.6 (371)*
E. Door Swing - in (mm)	24 (610)

* For ADA compliance turn legs out from base 0.5 inches

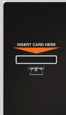
Models	Drain	Actuation
SFNNCASP116TW01	Pump	Coin Drop Installed 
SFNNCASG116TW01	Gravity	
SFNNYASP116TW01	Pump	Prep for Card 
SFNNYASG116TW01	Gravity	

Supply inject kits available.

** Average usage based on multiple load sizes and current DOE test protocol. Real usage will vary depending on load size, composition and cycle selectivity.

For the most accurate information, the installation guide should be used for all design and construction purposes. Due to continuous product improvements, design and specifications subject to change without notice. The quality management systems at Alliance Laundry Systems are registered to ISO 9001.