

Frigidaire

Factory Parts Catalog

Product No.	FGHT1846KE1	FGHT1846KF1	FGHT1846KP1	FGHT1846KR1
Series	Gallery	Gallery	Gallery	Gallery
Color	black (smooth)	stainless (RH)	white (smooth)	stainless (LH)
Volts	115	115	115	115
Wiring Diagram	241582401	241582401	241582401	241582401
Owner's Guide	242008000	242008000	242008000	242008000
Market	North America	North America	North America	North America
Energy Guide	241935550	241935550	241935550	241935550
Service Data Sheet	241588203	241588203	241588203	241588203
Installation Instructions	240568304	240568304	240568304	240568304



Electrolux Major Appliances
 North & Latin America
 P.O. BOX 212378
 AUGUSTA, GA 30917

Publication No.
5995541389
 09/05/28
 (EN/SERVICE/DCS)
 390

**TOP-MOUNT
 REFRIGERATOR**

**Model No.
 FGHT1846K**

Copyright © 2009 Electrolux Home Products, Inc.
 All rights reserved.

DOOR

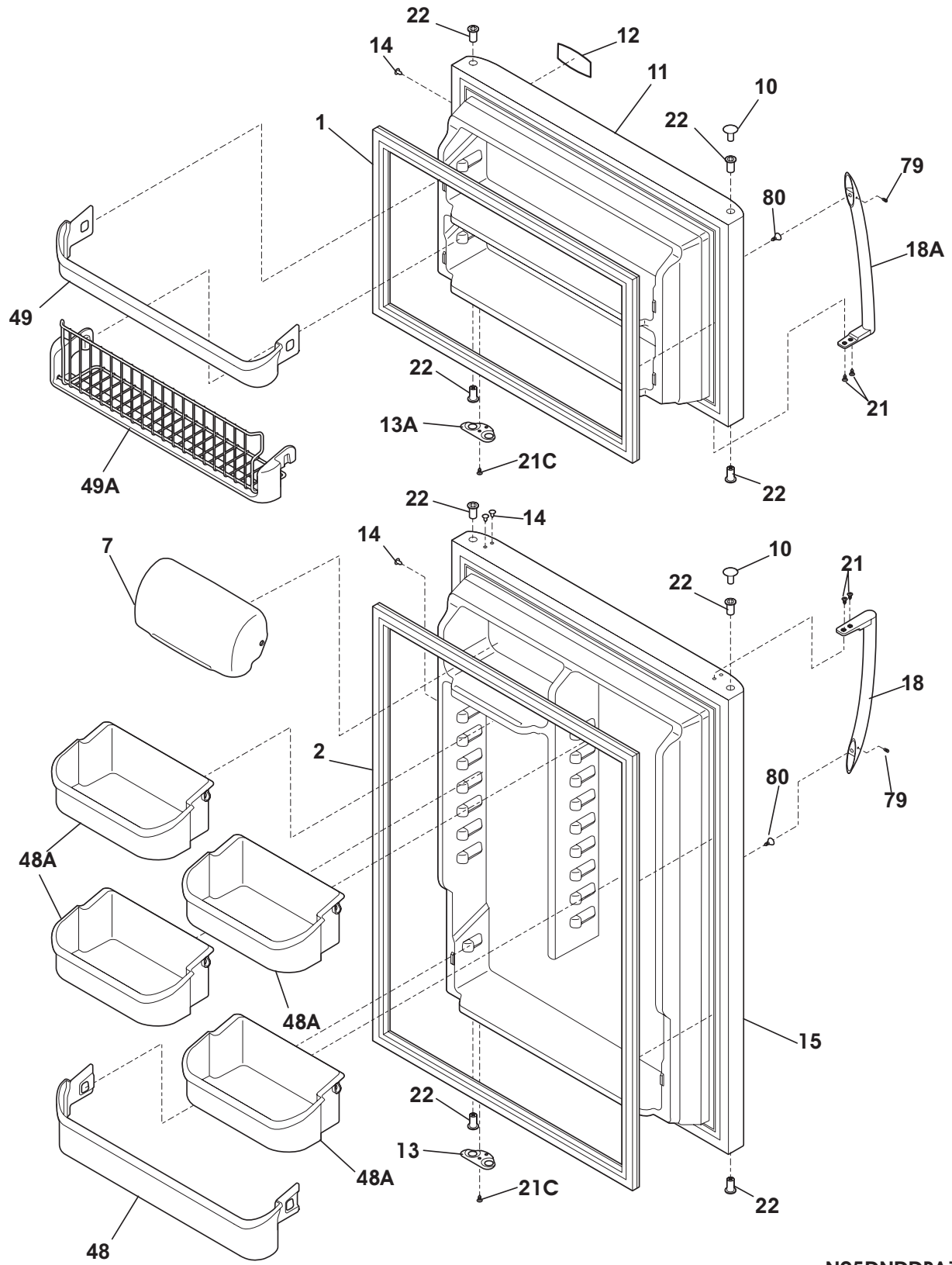

N05DNDDBA1

DOOR

Model Index: A FGHT1846K (FGHT1846KE1)
 B FGHT1846K (FGHT1846KF1)
 C FGHT1846K (FGHT1846KP1)
 D FGHT1846K (FGHT1846KR1)

POS. NO	PART NO.		DESCRIPTION
1	241872509	A B - D	Gasket-frzr door, black, magnetic
1	241872503	- - C -	Gasket-frzr door, white, magnetic
2	241872512	A B - D	Gasket-refr door, black, magnetic
2	241872506	- - C -	Gasket-refr door, white, magnetic
7	240338313	A B C D	Door, dairy, clear
10	240381303	A - - -	Plug-button, black, hinge brg hole
10	240381301	- - C -	Plug-button, white, hinge brg hole, (2)
11	240437409	A - - -	Panel-frzr door, black, complete assy
11	241623327	- B - -	Door-frzr, stainless, complete assy
11	240437407	- - C -	Panel-frzr door, white, complete assy
11	241623328	- - - D	Door-frzr, stainless, complete assy
12	242015201	A B C D	Label-nameplate
13	240312405	A B - D	Door Stop, black, refr
13	240312403	- - C -	Door Stop, white, refr
13A	240312415	A B - D	Door Stop, black, frzr
13A	240312414	- - C -	Door Stop, white, frzr
14	240494003	A - - -	Plug-button, black
14	240494001	- - C -	Plug-button, white
15	240438624	A - - -	Door-refr, black, complete assy
15	241623439	- B - -	Door-refr, stainless, complete assy
15	240438622	- - C -	Door-refr, white, complete assy
15	241623440	- - - D	Door-refr, stainless, complete assy
18	241977505	A - - -	Handle-door, black, refr-RH/frzr-LH
18	241977501	- B - D	Handle-door, stainless, refr-RH/frzr-LH
18	241977503	- - C -	Handle-door, white, refr-RH/frzr-LH
18*	241601001	A B C D	Wrench, allen
18*	241701901	A B C D	Screw Driver
18A	241977506	A - - -	Handle-door, black, refr-LH/frzr-RH
18A	241977502	- B - D	Handle-door, stainless, refr-LH/frzr-RH
18A	241977504	- - C -	Handle-door, white, refr-LH/frzr-RH
21	240383408	A - - -	Screw, truss hd quad, 10 x 16, black
21	240383406	- B - D	Screw, truss hd quad, #10-16 x .500, zinc
21	240383407	- - C -	Screw, truss hd quad, #10-16 x .500, white
21C	218252201	A B C D	Screw, #8 truss hd, 10-32CA x 0.500
22	240527102	A B - D	Bearing-hinge, black
22	240527101	- - C -	Bearing-hinge, natural color
48	240338101	A B C D	Bin-door, pseudo, bottom
48A	240338202	A B C D	Bin-door, gallon
48A*	241779603	A B C D	Liner, bin
49	240495804	A B C D	Bin-door, pseudo, frzr
49A	241801402	A B C D	Bin-tilt out, tilt-out
79	218755402	A B C D	Screw-set, 10-32 x 0.375
80	218755504	A B C D	Screw-shoulder, #10 AB, handle mounting

CABINET

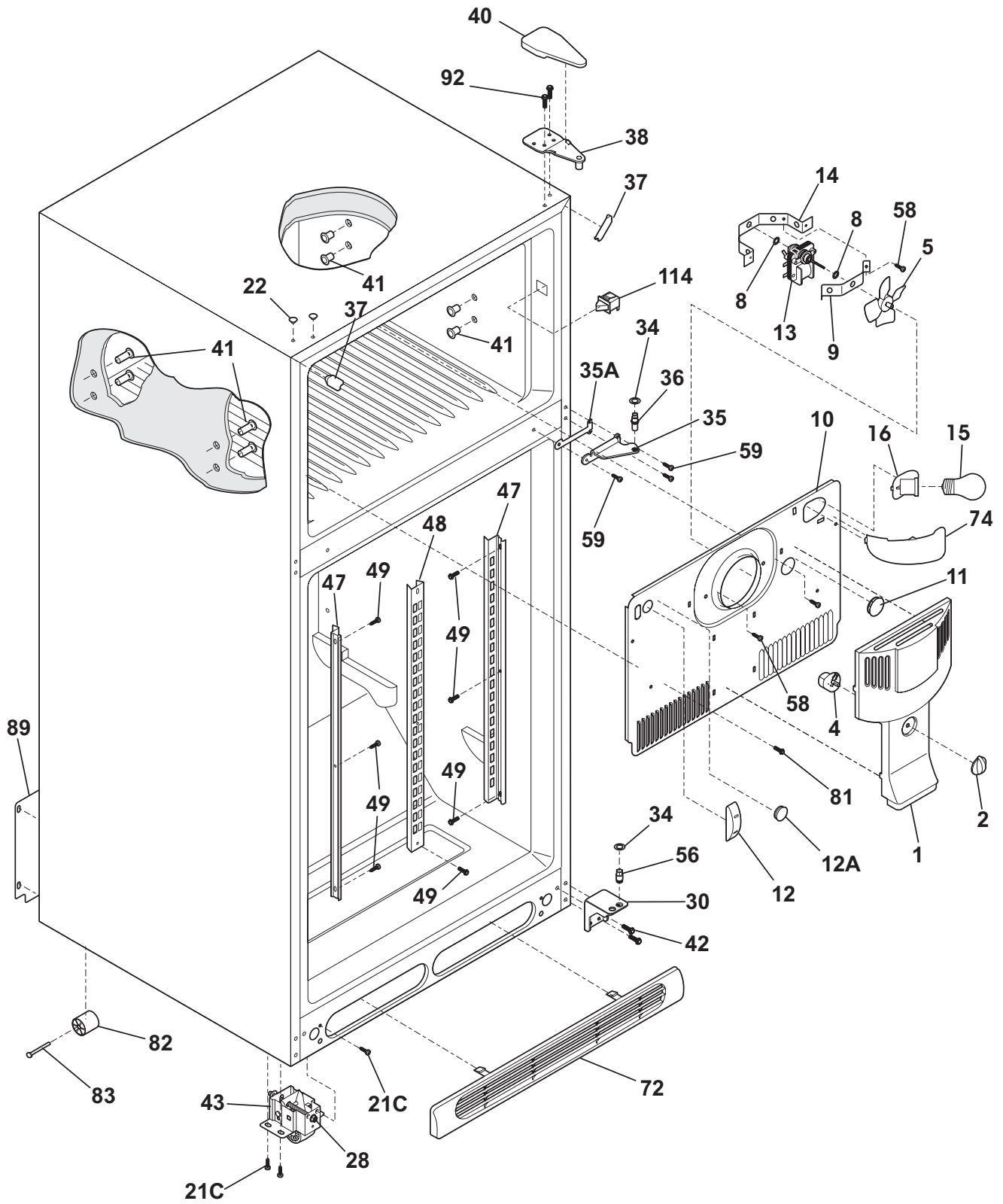

N05BAAABC10

CABINET

Model Index: A FGHT1846K (FGHT1846KE1)
 B FGHT1846K (FGHT1846KF1)
 C FGHT1846K (FGHT1846KP1)
 D FGHT1846K (FGHT1846KR1)

POS. NO	PART NO.		DESCRIPTION
1	241652301	A B C D	Cover-fan
2	240367001	A B C D	Knob-damper control
4	241523701	A B C D	Damper-fan cover
5 #	5308000010	A B C D	Fan Blade, red, evaporator fan
8	242014101	A B C D	Bushing-motor mtg, (2)
9	5303292396	A B C D	Bracket-motor mtg, front
10	241652213	A B C D	Cover-evap coil
10*	240568601	A B C D	Seal-coil cover
11	5303208309	A B C D	Plug-hole, factory test
12	241557601	A B C D	Plug-ice maker harness, rectangular
12A	240374401	A B C D	Plug-wtr inlet tube, round, 1"
12A*	241586701	A B C D	Plug-foam-wtr-inlet, round
13 #	241854501	A B C D	Motor-evap fan
13*	215474201	A B C D	Washer, "slinger", nylon, evap fan shaft
13*	218515401	A B C D	Clip
14	5303292397	A B C D	Bracket-motor mtg, rear
14*	240433204	A B C D	Screw, hex washer head, 8-18 x 5/16
15	241560701	A B C D	Light Bulb
16 #	241513901	A B C D	Socket-light
21C	218252201	A B C D	Screw, #8 truss hd, 10-32CA x 0.500
22	215774918	A B - D	Plug-button, black, upr hinge holes
22	215774901	- - C -	Plug-button, white, upr hinge holes
28	240335502	A B C D	Bolt-roller adj, hex washer head, 1/4-20 x 4.020, (2), special
30	240314003	A B - D	Bracket-lower hinge, black
30	240314011	- - C -	Bracket-lower hinge, zinc
34	240311303	A B C D	Washer, hinge, nylon, (2)
35	240313803	A B - D	Bracket-ctr hinge, black
35	240313806	- - C -	Bracket-ctr hinge, zinc
35A	240336803	A B - D	Spacer-hinge, center, black
35A	240336802	- - C -	Spacer-hinge, center
36	240516402	A B C D	Pin-center hinge
37	241611303	A B - D	Trim-cabinet corner, black, (2)
37	241611301	- - C -	Trim-cabinet corner, white, (2)
38	240313701	A B C D	Bracket-upper hinge
40	240354404	A B - D	Cover-upper hinge, black
40	240354401	- - C -	Cover-upper hinge, white
41	5308009759	A B C D	Grommet, shelf mtg, 1.25", LH, (4)
42	240578902	A B C D	Screw, hex head, 1/4-20 x 5/8
43	240335005	A B C D	Roller Assy, adjustable, front, (2)
47	218233301	A B C D	Channel-shelf mtg, side, (2)
48	241566901	A B C D	Channel-shelf mtg, center (ml)
49	218362501	A B C D	Screw, hex washer head, 8-18AB x 1.250, spacer, (2)
56	240516502	A B C D	Pin-lower hinge
58	5304456287	A B C D	Screw, hex washer head, 8-15A x 0.500
59	240442707	A B - D	Screw-#10-32 X 3/4, black
59	240442706	- - C -	Screw-#10-32 X 3/4, zinc
72	241839407	A B - D	Grille/Kickplate, black

CABINET

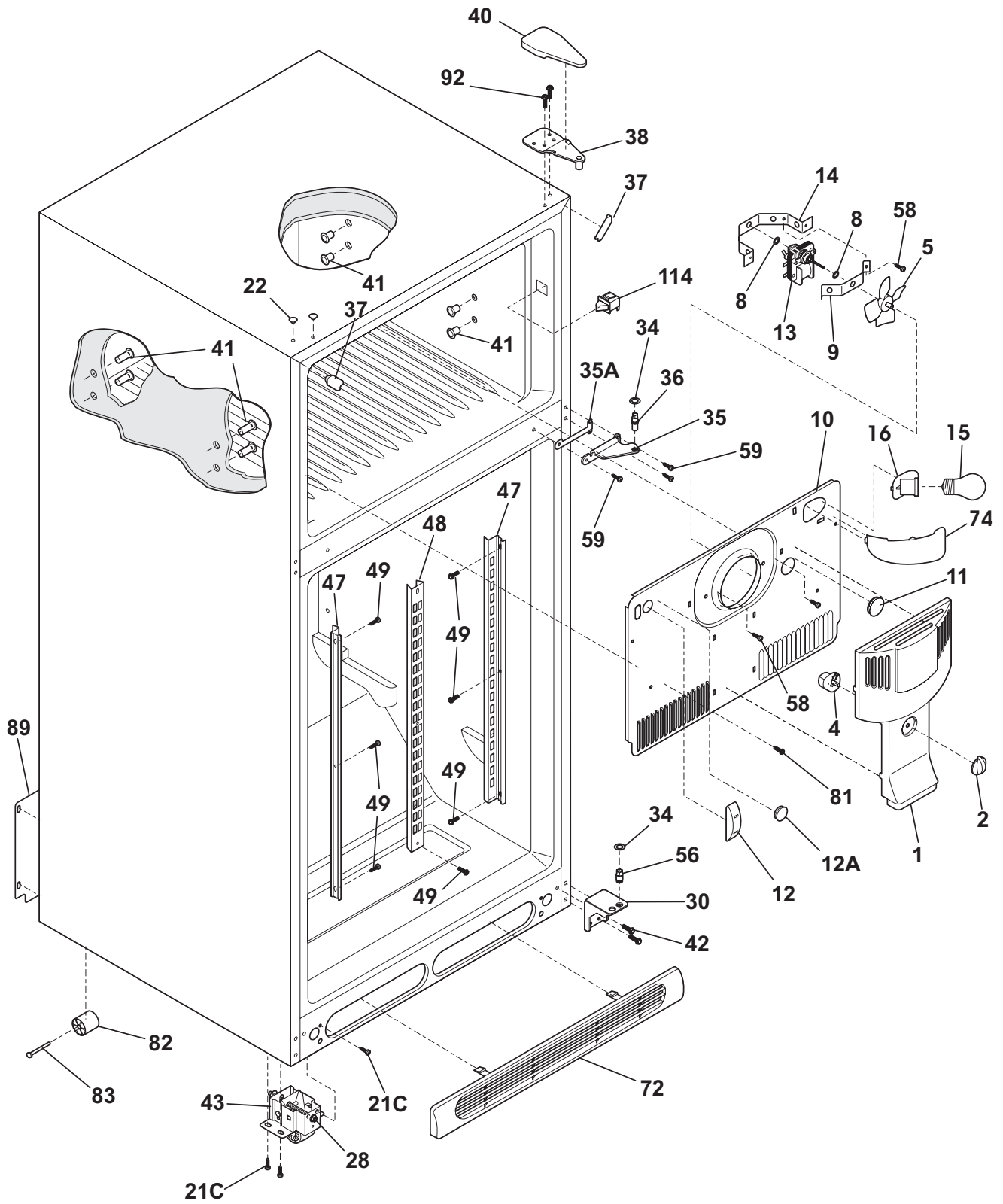

N05BAAABC10

CABINET

Model Index: A FGHT1846K (FGHT1846KE1)
 B FGHT1846K (FGHT1846KF1)
 C FGHT1846K (FGHT1846KP1)
 D FGHT1846K (FGHT1846KR1)

POS. NO	PART NO.		DESCRIPTION
72	241839405	- - C -	Grille/Kickplate, white
74	240354302	A B C D	Shield-light, frzr
81	5304455650	A B C D	Screw, hex washer head, 8-15A x 0.625, low profile
82	5304418225	A B C D	Roller, compressor base, rear, (2)
83	5304455655	A B C D	Rivet, flat head, 1/4 OD x 1-3/4, roller pin
89	241733907	A B C D	Cover-access, with label
89*	241500304	A B C D	Screw, hex washer head, 8-18AB x 0.625
92	241710601	A B C D	Screw, hex washer hd, 1/4 x 7/8, hinge mtg
114	241554901	A B C D	Switch-light/lamp
*	240479601	A B C D	Plug, button, cab liner holes
*	5303321321	A B - D	Paint, touch-up, black
*	5303321319	- - C -	Paint, touch-up, white

SHELVES

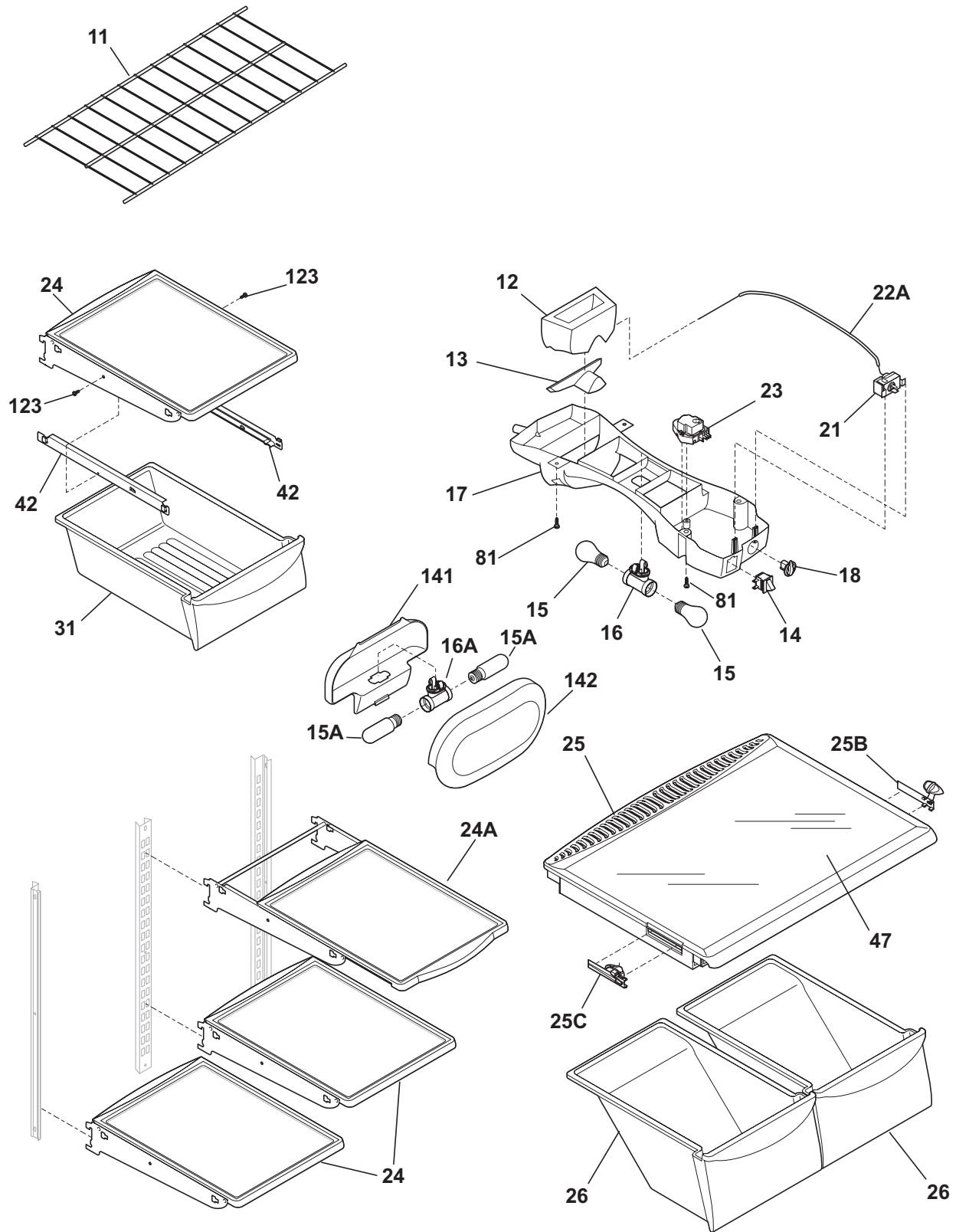

N05SADAFX1

SHELVES

Model Index: A FGHT1846K (FGHT1846KE1)
 B FGHT1846K (FGHT1846KF1)
 C FGHT1846K (FGHT1846KP1)
 D FGHT1846K (FGHT1846KR1)

POS. NO	PART NO.		DESCRIPTION
11	240358005	A B C D	Shelf, freezer, full-width, wire
12	241542001	A B C D	Diffuser, air, top
13	240362601	A B C D	Diffuser, air, bottom
14 #	241554901	A B C D	Switch-light/lamp
15	241555401	A B C D	Light Bulb
15A	241552802	A B C D	Light Bulb
16	240364202	A B C D	Socket-light/lamp, dual
16A	241507803	A B C D	Socket-light
16A*	241593901	A B C D	Harness-wiring
17	240352701	A B C D	Control Box
17*	241566801	A B C D	Harness-wiring, c/box M/Level
18	240360801	A B C D	Knob, temp control
21 #	5304421256	A B C D	Control, temperature
22A	240468201	A B C D	Tube, sensor sleeve, 31 inch, plastic, white
23 #	215846606	A B C D	Timer, defrost, 60 Hz, 0.25 W, 120 V, 10 hour/30 min
23*	5304455649	A B C D	Screw, pan hd, 6-20 x 0.438
24	241616607	A B C D	Shelf-"Spill-Safe", cantilever, half width, fixed
24A	241730504	A B C D	Shelf-"Spill-Safe", cantilever, sliding
25	240364787	A B C D	Cover-crisper pan
25B	241613501	A B C D	Control-humidity, RH
25C	241613502	A B C D	Control-humidity, LH
26	240337103	A B C D	Pan-crisper, clear, (2), no graphics
31	240530811	A B C D	Pan-meat, w/o graphics, clear
42	240356501	A B C D	Track, meat pan hanger, RH
42	240365401	A B C D	Track, meat pan hanger, LH
47	240350608	A B C D	Insert-pan cover, 23.82" x 15.50", glass
81	5304455650	A B C D	Screw, hex washer head, 8-15A x 0.625, low profile
123	215005101	A B C D	Screw, hanger/rlr mtg, 8-10 x 7/16
141	241562101	A B C D	Shield-heat, Mid Level
142	241562202	A B C D	Shield-light Mid Level
*	241935550	A B C D	Energy Guide

SYSTEM

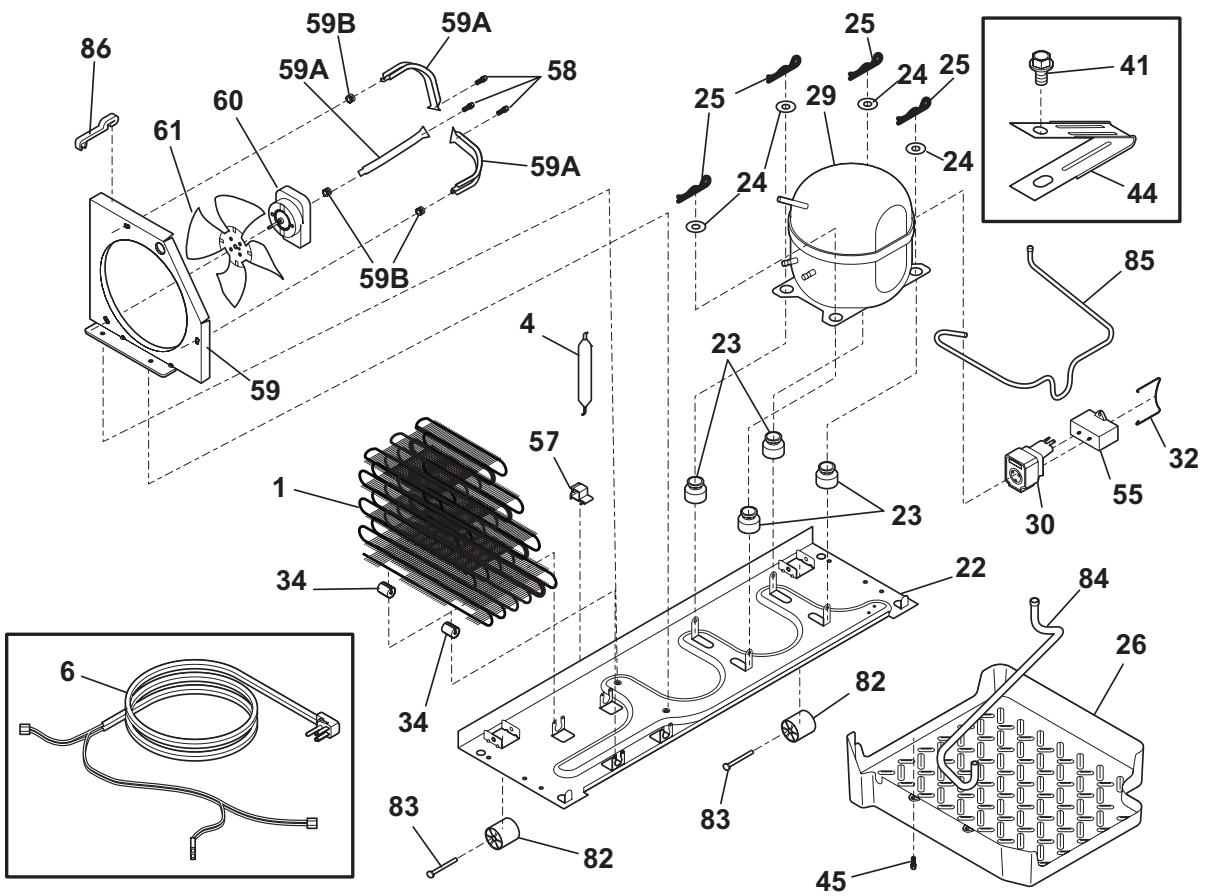
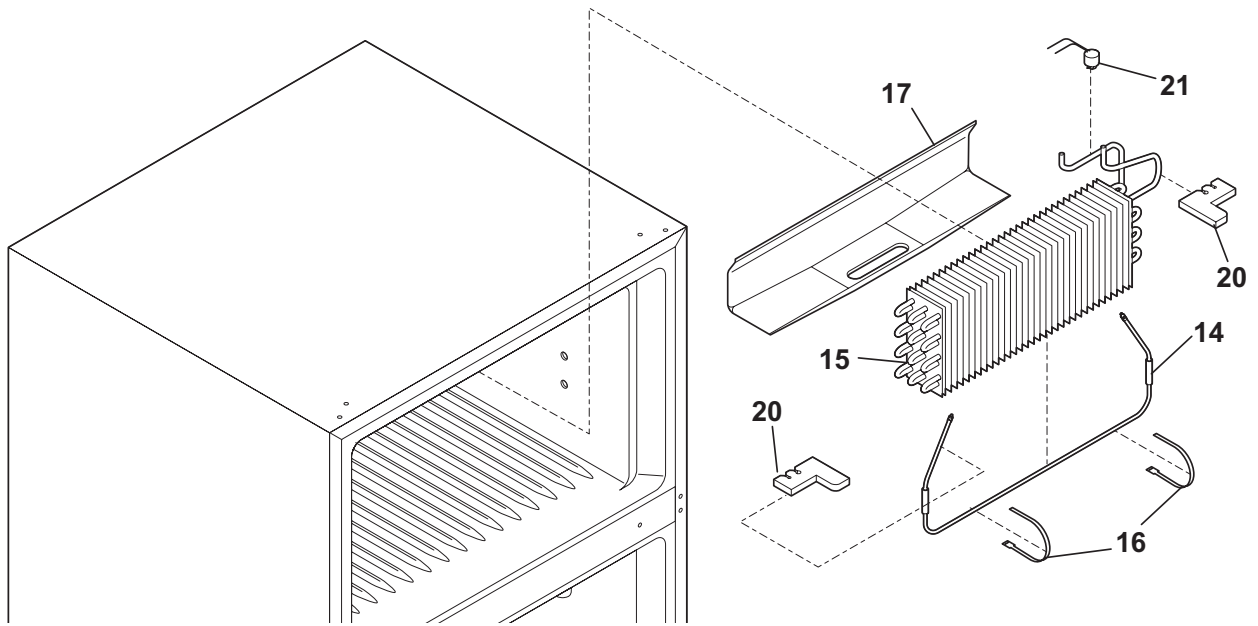

N05CAABAD4

SYSTEM

Model Index: **A** FGHT1846K (FGHT1846KE1)
 B FGHT1846K (FGHT1846KF1)
 C FGHT1846K (FGHT1846KP1)
 D FGHT1846K (FGHT1846KR1)

POS. NO	PART NO.		DESCRIPTION
1 #	241785402	A B C D	Condenser, dynamic
4	218944002	A B C D	Drier-filter, R134a System
6 #	241607001	A B C D	Harness-wiring, machine compt
6*	241566801	A B C D	Harness-wiring, c/box M/Level
14 #	240356221	A B C D	Heater-defrost
15 #	5303918274	A B C D	Evaporator Kit
16	5308000110	A B C D	Strap-evap/heater, aluminum, (2)
17	241801301	A B C D	Trough-drain
20	241551902	A B C D	Insulation Block
21 #	5303918202	A B C D	Thermostat-defrost, kit
22	241665606	A B C D	Base-compressor
22*	218252201	A B C D	Screw, #8 truss hd, 10-32CA x 0.500
23	218513300	A B C D	Grommet-compr mtg, (4)
24	241812301	A B C D	Washer-compr mtg
25	216056401	A B C D	Clip-compressor mtg
26	241683601	A B C D	Pan-defrost
29 #	5303918415	A B C D	Compressor Kit
30 #	241707720	A B C D	Starter-PTC
32	216649200	A B C D	Clip, controller
34	240405201	A B C D	Grommet, rubber, black, cond tube/wire
41	240433204	A B C D	Screw, hex washer head, 8-18 x 5/16
44	5304456288	A B C D	Clamp-wiring harness, strain relief, galv steel
45	241500304	A B C D	Screw, hex washer head, 8-18AB x 0.625
55	218909913	A B C D	Capacitor, run, 220 VAC, 15 microfarad
57	240542601	A B C D	Clip-wiring harness
58	240569201	A B C D	Screw, 8-18 x 0.500
59	240315505	A B C D	Shroud-cond fan
59*	240346701	A B C D	Tape-foam seal, shroud
59*	240359403	A B C D	Screw-fan shroud, (2)
59A	240346501	A B C D	Bracket-support, cond mtr, (3)
59B	240346601	A B C D	Grommet-bracket, (3)
60	241584301	A B C D	Motor-condenser fan
61	241639501	A B C D	Blade-condenser fan
82	5304418225	A B C D	Roller, compressor base, rear, (2)
83	5304455655	A B C D	Rivet, flat head, 1/4 OD x 1-3/4, roller pin
84	240500801	A B C D	Tube-drain, rubber, lower
85	242014601	A B C D	Tube-connector, suction
86	240409302	A B C D	Spacer-cond tube, black
*	240396801	A B C D	Clamp, tube/wiring, nylon, black/natural
*	5303918222	A B C D	Hot Tube Repair Kit, service
*	5303918263	A B C D	Heat Exchanger Kit, suction line

WIRING SCHEMATIC

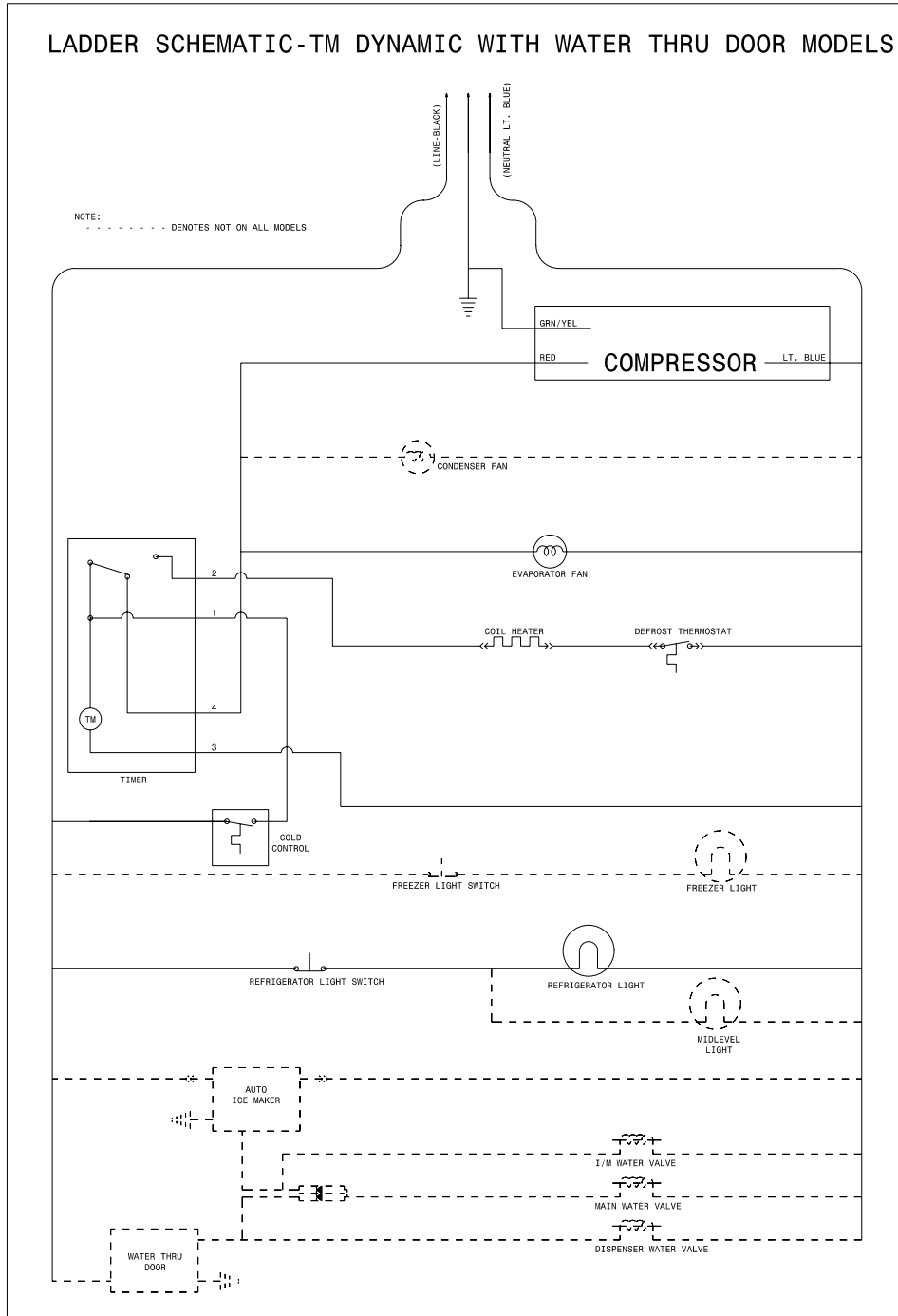

WIRING DIAGRAM

