

*Frigidaire*

Factory Parts Catalog

Product No.	FGHT2134KB0	FGHT2134KW0	FGHT2144KF0	FGHT2144KR0
Series	Gallery	Gallery	Gallery	Gallery
Color	black	white	stainless RH	stainless lh
Volts	115	115	115	115
Wiring Diagram	241582401	241582401	241582401	241582401
Owner's Guide	242008000	242008000	242008000	242008000
Market	North America	North America	North America	North America
Energy Guide	241935552	241935552	241935553	241935553
Service Data Sheet	241588203	241588203	241588203	241588203
Installation Instructions	240568304	240568304	240568304	240568304



Electrolux Major Appliances  
 North & Latin America  
 P.O. BOX 212378  
 AUGUSTA, GA 30917

Publication No.  
**5995535399**  
 09/03/13  
 (EN/SERVICE/DCS)  
 137

**TOP-MOUNT  
 REFRIGERATOR**

Model No.  
**FGHT2134K /  
 FGHT2144K**

Copyright © 2009 Electrolux Home Products, Inc.  
 All rights reserved.



**DOOR**

*Model Index:* A FGHT2134K (FGHT2134KB0)  
 B FGHT2134K (FGHT2134KW0)  
 C FGHT2144K (FGHT2144KF0)  
 D FGHT2144K (FGHT2144KR0)

POS. NO	PART NO.		DESCRIPTION
1 #	241872511	A - C D	Gasket-frzr door, black, magnetic
1	241872505	- B - -	Gasket-frzr door, white, magnetic
2 #	241872514	A - C D	Gasket, refr door seal, black, magnetic
2 #	241872513	- B - -	Gasket, refr door seal, white, magnetic
7	240338303	A B C D	Door, dairy, clear
10	240381303	A - - -	Plug-button, black, hinge brg hole
10	240381301	- B - -	Plug-button, white, hinge brg hole, (2)
11	241798413	A - - -	Door-frzr, black, complete assy
11	241798401	- B - -	Door-frzr, white, complete assy
11	240450394	- - C -	Door-frzr, stainless, complete assy
11	240450393	- - - D	Door-frzr, stainless, complete assy
12	242015201	A B C D	Label-nameplate
13	240312405	A - C D	Door Stop, black, refr
13	240312403	- B - -	Door Stop, white, ref
13A	240312406	A - C D	Door Stop, black, frzr
13A	240312404	- B - -	Door Stop, white, frzr
14	240494003	A - - -	Plug-button, black
14	240494001	- B - -	Plug-button, white
15	241798552	A - - -	Door-refr, black, complete assy
15	241798551	- B - -	Door-refr, white, complete assy
15	241837285	- - C -	Door-refr, stainless, complete assy
15	241837284	- - - D	Door-refr, stainless, complete assy
18	241977203	A - - -	Handle-door, black, refr-RH/frzr-LH
18	241977201	- B - -	Handle-door, white, refr-RH/frzr-LH
18	241977501	- - C D	Handle-door, stainless, refr-RH/frzr-LH
18*	241601001	- - C D	Wrench, allen
18*	241701901	- - C D	Screw Driver
18A	241977206	A - - -	Handle-door, black, frzr-RH/refr-LH
18A	241977204	- B - -	Handle-door, white, frzr-RH/refr-LH
18A	241977502	- - C D	Handle-door, stainless, refr-LH/frzr-RH
21	240383406	A B C D	Screw, truss hd quad, #10-16 x .500, zinc
21C	218252201	A B C D	Screw, #8 truss hd, 10-32CA x 0.500
22	240527102	A - C D	Bearing-hinge, black
22	240527101	- B - -	Bearing-hinge, natural color
48	240338101	A B C D	Bin-door, pseudo, bottom
48A	240338201	A B C D	Bin-door, gallon, white
49	240495804	A B C D	Bin-door, pseudo, frzr
79	218755402	A B C D	Screw-set, 10-32 x 0.375
80	218755504	A B C D	Screw-shoulder, #10 AB, handle mounting

CABINET

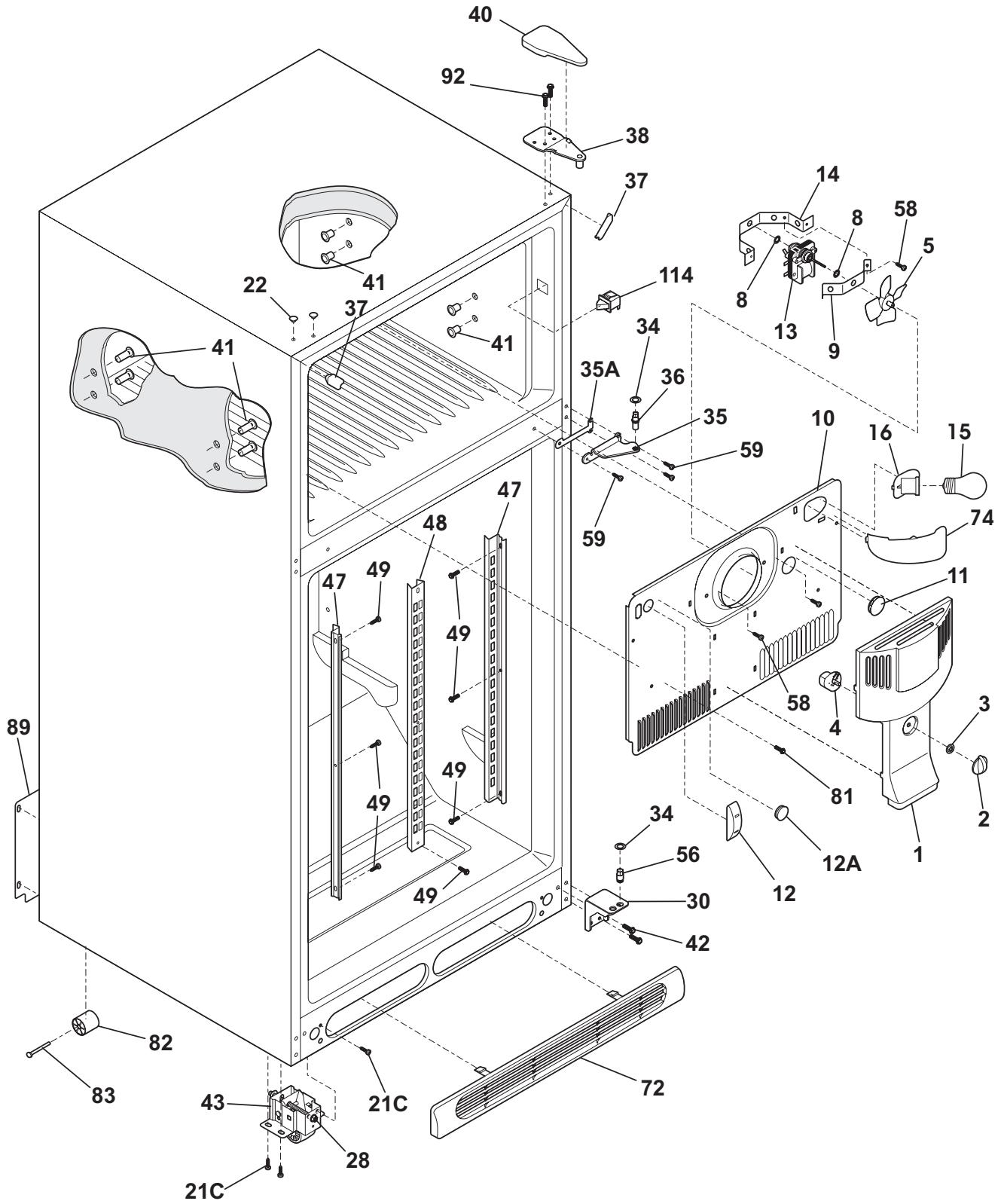

N05BAAABC8

**CABINET**

*Model Index:* A FGHT2134K (FGHT2134KB0)  
 B FGHT2134K (FGHT2134KW0)  
 C FGHT2144K (FGHT2144KF0)  
 D FGHT2144K (FGHT2144KR0)

POS. NO	PART NO.		DESCRIPTION
1	240355402	A B C D	Cover-fan
2	240367001	A B C D	Knob-damper control
3	5303212803	A B C D	Nut
4	240367401	A B C D	Damper-fan cover
5 #	5308000010	A B C D	Fan Blade, red, evaporator fan
8	5300157666	A B C D	Bushing-motor mtg, (2)
9	5303292396	A B C D	Bracket-motor mtg, front
10	240313611	A B C D	Cover-evap coil, w/light
10*	240568606	A B C D	Seal-coil cover
11	5303208309	A B C D	Plug-hole, factory test
12	241557601	A B C D	Plug-ice maker harness, rectangular
12A	240374401	A B C D	Plug-wtr inlet tube, round, 1"
12A*	241586701	A B C D	Plug-foam-wtr-inlet, round
13 #	241854501	A B C D	Motor-evap fan
13*	215474201	A B C D	Washer, "slinger", nylon, evap fan shaft
14	5303292397	A B C D	Bracket-motor mtg, rear
14*	240433204	A B C D	Screw, hex washer head, 8-18 x 5/16
15	241560701	A B C D	Light Bulb
16 #	241513901	A B C D	Socket-light
21C	218252201	A B C D	Screw, #8 truss hd, 10-32CA x 0.500
22	215774918	A - C D	Plug-button, black, upr hinge holes
22	215774901	- B - -	Plug-button, white, upr hinge holes
28	240335502	A B C D	Bolt-roller adj, hex washer head, 1/4-20 x 4.020, (2), special
30	240314003	A - C D	Bracket-lower hinge, black
30	240314011	- B - -	Bracket-lower hinge, zinc
34	240311303	A B C D	Washer, hinge, nylon, (2)
35	240313803	A - C D	Bracket-ctr hinge, black
35	240313806	- B - -	Bracket-ctr hinge, zinc
35A	240336803	A - C D	Spacer-hinge, center, black
35A	240336802	- B - -	Spacer-hinge, center
36	240516402	A B C D	Pin-center hinge
37	240337610	A - C D	Trim-cabinet corner, black, (2)
37	240337608	- B - -	Trim-cabinet corner, white, (2)
38	240313701	A B C D	Bracket-upper hinge
40	240354404	A - C D	Cover-upper hinge, black
40	240354401	- B - -	Cover-upper hinge, white
41	5308009759	A B C D	Grommet, shelf mtg, 1.25", LH, (4)
42	240578902	A B C D	Screw, hex head, 1/4-20 x 5/8
43	240335006	A B C D	Roller Assy, front, (2)
47	218233301	A B C D	Channel-shelf mtg, side, (2)
48	5303292395	A B C D	Channel-shelf mtg, center
49	218362501	A B C D	Screw, hex washer head, 8-18AB x 1.250, spacer, (2)
56	240516502	A B C D	Pin-lower hinge
58	5304456287	A B C D	Screw, hex washer head, 8-15A x 0.500
59	240442707	A - C D	Screw-#10-32 X 3/4, black
59	240442706	- B - -	Screw-#10-32 X 3/4, zinc
72	241839407	A - C D	Grille/Kickplate, black

CABINET

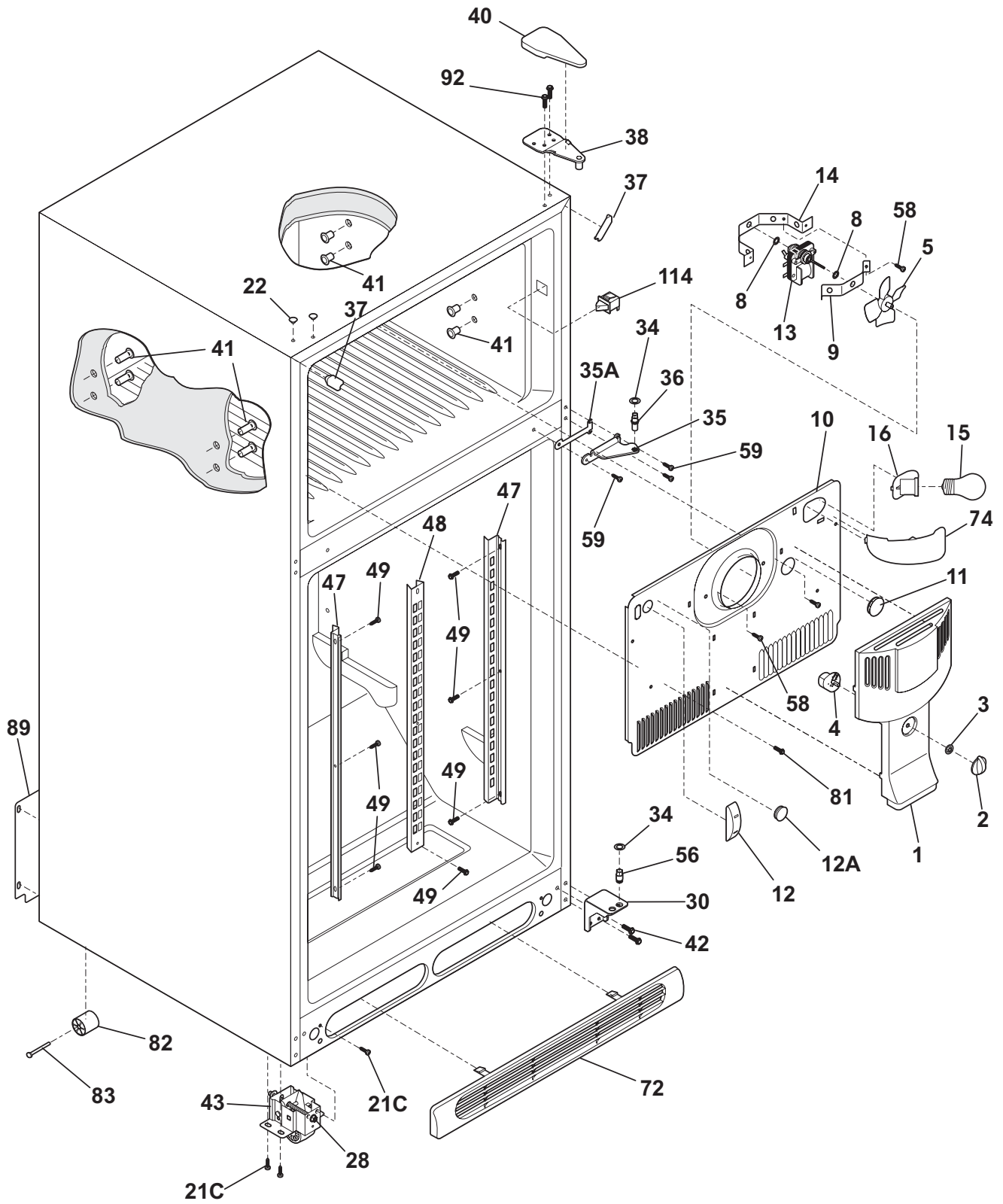

N05BAAABC8

**CABINET**

*Model Index:*    **A** FGHT2134K (FGHT2134KB0)  
                           **B** FGHT2134K (FGHT2134KW0)  
                           **C** FGHT2144K (FGHT2144KF0)  
                           **D** FGHT2144K (FGHT2144KR0)

POS. NO	PART NO.		DESCRIPTION
72	241839405	- B - -	Grille/Kickplate, white
74	240354302	A B C D	Shield-light, frzr
81	5304455650	A B C D	Screw, hex washer head, 8-15A x 0.625, low profile
82	5304418225	A B C D	Roller, compressor base, rear, (2)
83	5304455655	A B C D	Rivet, flat head, 1/4 OD x 1-3/4, roller pin
89	241733907	A B C D	Cover-access, with label
89*	241500303	A B C D	Screw, hex washer head, 8-18AB x 0.500
92	241710601	A B C D	Screw, hex washer hd, 1/4 x 7/8, hinge mtg
114	240505801	A B C D	Switch, light/lamp
*	240479601	A B C D	Plug, button, cab liner holes
*	5303321321	A - C D	Paint, touch-up, black
*	5303321319	- B - -	Paint, touch-up, white

**SHELVES**

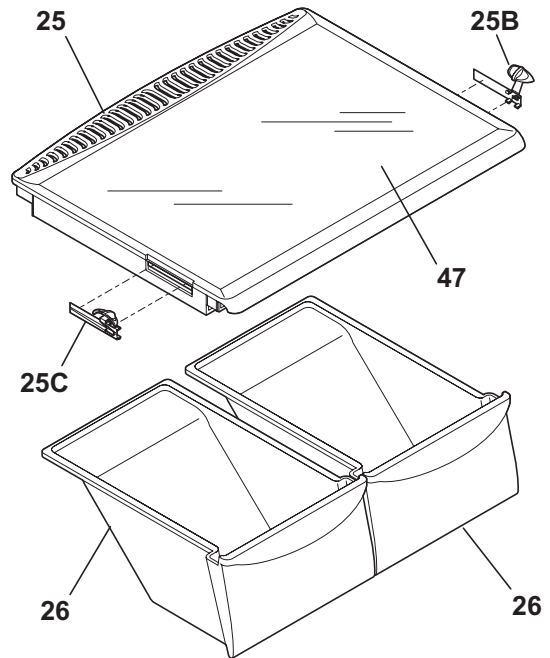
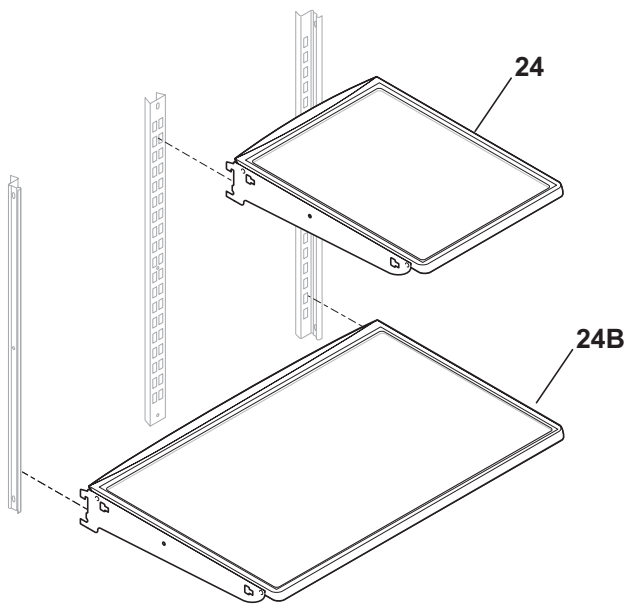
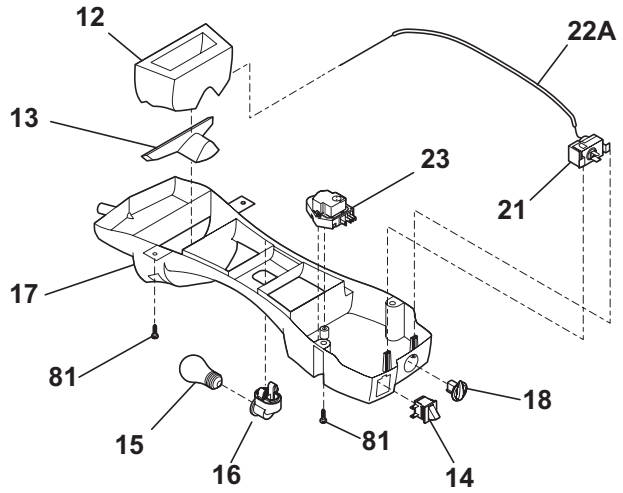
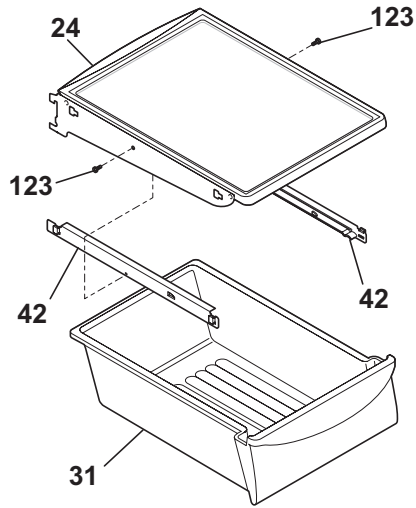
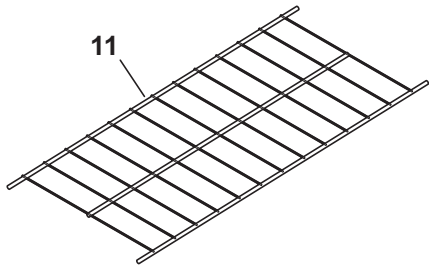

**N05SADAFH1**



**SHELVES**

*Model Index:* A FGHT2134K (FGHT2134KB0)  
 B FGHT2134K (FGHT2134KW0)  
 C FGHT2144K (FGHT2144KF0)  
 D FGHT2144K (FGHT2144KR0)

POS. NO	PART NO.		DESCRIPTION
11	240358006	A B C D	Shelf, freezer, full-width, wire
12	240545901	A B C D	Diffuser-air, top
13	240362601	A B C D	Diffuser, air, bottom
14 #	241554901	A B C D	Switch-light/lamp
15	241555401	A B C D	Light Bulb
16	241559801	A B C D	Socket-light
17	240368102	A B C D	Control Box
17*#	240388701	A B C D	Wiring Harness, control box
18	240360801	A B C D	Knob, temp control
21#	5304445058	A B C D	Control-temperature
22A	240468201	A B C D	Tube, sensor sleeve, 31 inch, plastic, white
23 #	215846606	A B C D	Timer, defrost, 60 Hz, 0.25 W, 120 V, 10 hour/30 min
23*	5304455649	A B C D	Screw, pan hd, 6-20 x 0.438
24	240355261	A B C D	Shelf-"Spill-Safe", fixed
24B	240408909	A B C D	Shelf-"Spill-Safe", cantilever fixe
25	240364790	A B C D	Cover-crisper pan
25B	241613501	A B C D	Control-humidity, RH
25C	241613502	A B C D	Control-humidity, LH
26	240343803	A B C D	Pan, crisper, (2)
31	240530803	A B C D	Pan-meat, w/o graphics, clear
42	240356501	A B C D	Track, meat pan hanger, RH
42	240365401	A B C D	Track, meat pan hanger, LH
47	240350609	A B C D	Insert-pan cover, glass
81	5304455650	A B C D	Screw, hex washer head, 8-15A x 0.625, low profile
123	215005101	A B C D	Screw, hanger/r/r mtg, 8-10 x 7/16
*	241935552	A B - -	Energy Guide
*	241935553	- - C D	Energy Guide

**SYSTEM**

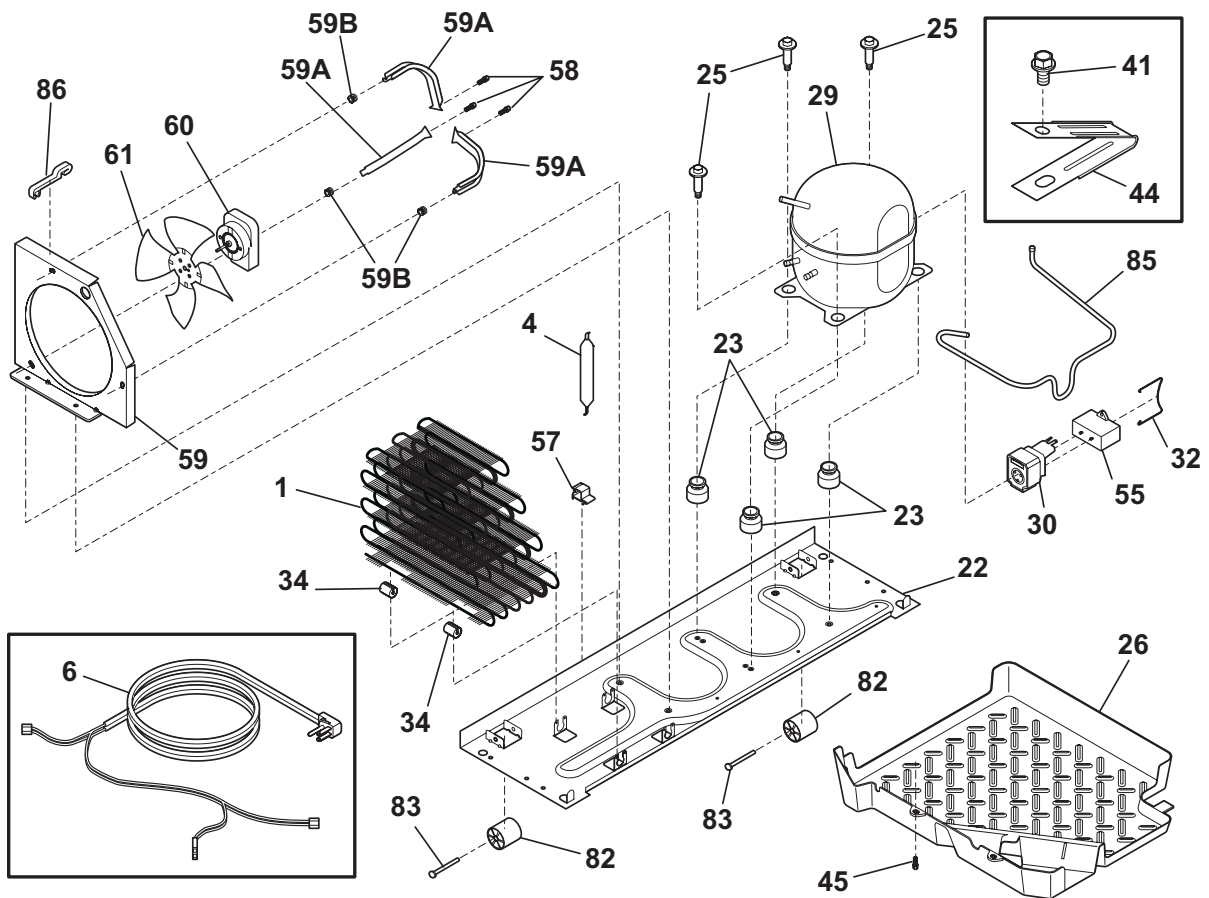
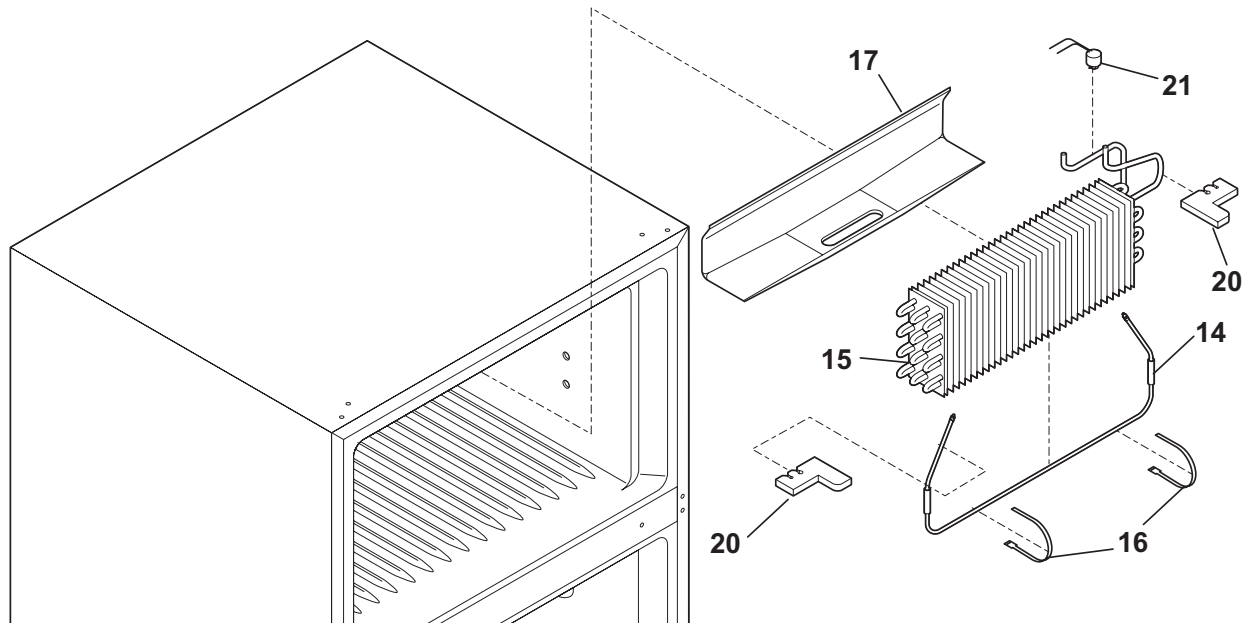

N05CAAAC9

## SYSTEM

*Model Index:*    **A** FGHT2134K (FGHT2134KB0)  
                           **B** FGHT2134K (FGHT2134KW0)  
                           **C** FGHT2144K (FGHT2144KF0)  
                           **D** FGHT2144K (FGHT2144KR0)

POS. NO	PART NO.		DESCRIPTION
1	241965001	A B C D	Condenser, dynamic
4 #	218944001	A B C D	Drier-filter, R134a System
6 #	241607001	A B C D	Harness-wiring, machine compt
6* #	240388701	A B C D	Wiring Harness, control box
14 #	241940103	A B C D	Heater-defrost
15 #	5303918274	A B C D	Evaporator Kit
16	5308000110	A B C D	Strap-evap/heater, aluminum, (2)
17	241801301	A B C D	Trough-drain
20	241551902	A B C D	Insulation Block
21 #	5303918202	A B C D	Thermostat-defrost, kit
22	241602010	A B C D	Base-compressor
22*	218252201	A B C D	Screw, #8 truss hd, 10-32CA x 0.500
22*	218709101	A B C D	Screw, hex head, 10-32 x 0.500
23	241659701	A B C D	Grommet, compressor
25	240491503	A B C D	Screw-compressor mtg, 1/4-28 x 1.16, (4)
26	241637401	A B C D	Pan-defrost
29 #	5303918359	A B C D	Compressor, w/o electricals
30 #	241707701	A B C D	Starter, PTC
32	241650901	A B C D	Clamp, elec cont mtg, compressor
34	240405201	A B C D	Grommet, rubber, black, cond tube/wire
41	240555002	A B C D	Screw-#8-32 X 3/8
44	215174700	A B C D	Clamp-service cord, strain relief, galv steel
45	5304455650	A B C D	Screw, hex washer head, 8-15A x 0.625, low profile
55	218909913	A B C D	Capacitor, run, 220 VAC, 15 microfarad
57	240542601	A B C D	Clip-wiring harness
58	240433203	A B C D	Screw, hex washer head, 8-18 x 3/8
59	240315502	A B C D	Shroud-cond fan
59*	240346701	A B C D	Tape-foam seal, shroud
59*	240359403	A B C D	Screw-fan shroud, (2)
59A	240346501	A B C D	Bracket-support, cond mtr, (3)
59B	240346601	A B C D	Grommet-bracket, (3)
60	241584301	A B C D	Motor-condenser fan
61	241639501	A B C D	Blade-condenser fan
82	5304418225	A B C D	Roller, compressor base, rear, (2)
83	5304455655	A B C D	Rivet, flat head, 1/4 OD x 1-3/4, roller pin
85	241844801	A B C D	Tube-connector, suction
86	240409302	A B C D	Spacer-cond tube, black
* #	240396801	A B C D	Clamp, tube/wiring, nylon, black/natural
* #	5303918330	A B C D	Heat Exchanger Kit, suction line, service
* #	5304421289	A B C D	Hot Tube Repair Kit, service

### WIRING SCHEMATIC

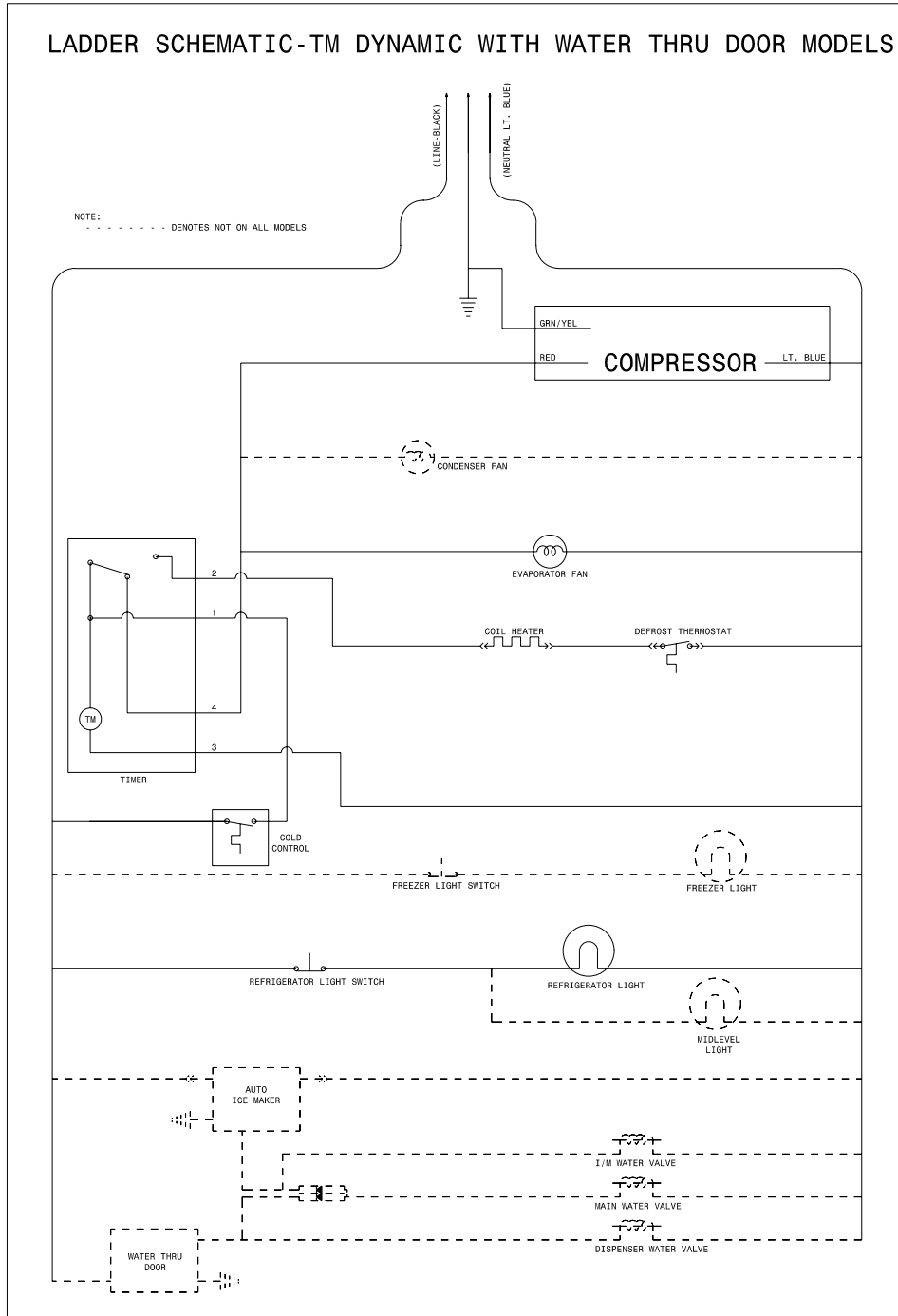

WIRING DIAGRAM

