

Frigidaire

Factory Parts Catalog

Product No.	FFU17F5HBA
Series	EZ Set
Color	black
Volts	115
Wiring Diagram	297246001
Owner's Guide	297245700
Market	North America
Energy Guide	216795415

 **Electrolux**

Electrolux Major Appliances
North & Latin America
P.O. BOX 212378
AUGUSTA, GA 30917

Publication No.
5995515292
08/05/22
(EN/SERVICE/MLR)
365

UPRIGHT FREEZER

Model No.
FFU17F5HB

Copyright © 2008 Electrolux Home Products, Inc.
All rights reserved.

DOOR

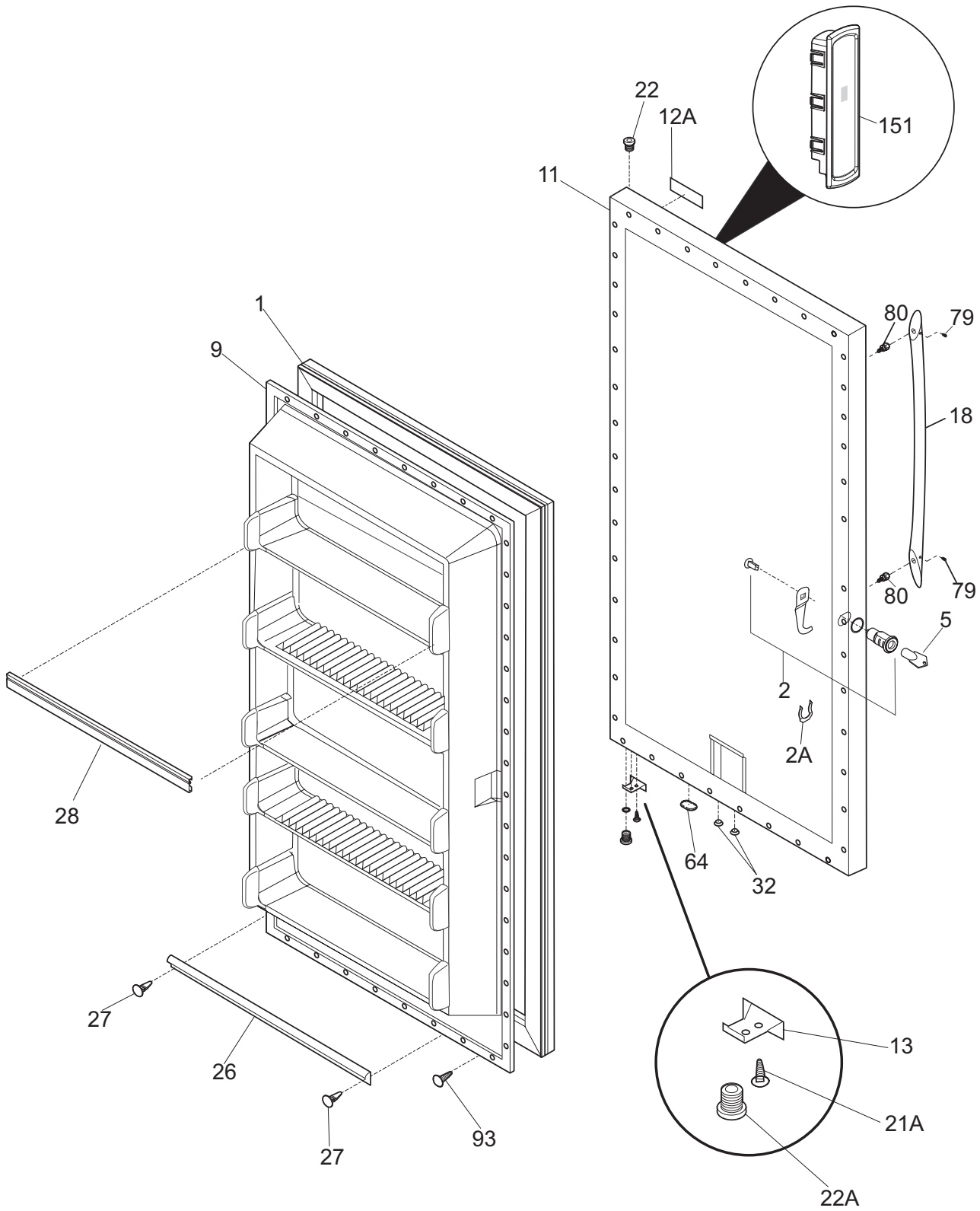

P08D0561

DOOR

POS. NO	PART NO.	DESCRIPTION
1	216522311	Gasket-door, black
2 #	297213400	Lock Assy
2A	297213300	Clip, spring
5	297147700	Key, lock
9	216527816	Panel-inner door, frzr
11	297245203	Panel-outer door, black
12A	241808601	Label-nameplate
13	297148400	Door Stop
18	297233801	Handle-door, black
*	240537301	Nut-anchor, door hdl screw
21A	297197500	Screw, door stop mtg, FH38-16X.750, P Twin
22	216970800	Bearing, hinge w/o'ring, top
22A	297006800	Bearing-hinge, btm, w/o'ring
26	216524200	Gasket, secondary
27	5303212828	Clip, panel mtg
27*	5304406520	Clip, panel mtg kit, (40)
28	216951600	Rack-door, (5)
32	5309950074	Valve, breather
64	216403700	Plug-button, hole filler, door base
79	218755404	Screw-set, 10-32 x 1.100
80	218755504	Screw-shoulder, #10 AB, handle mounting
93	5304460605	Screw, ph truss head, 8-18AB x 0.500
151#	297241801	Control-electronic, assy, black, 115V

CABINET

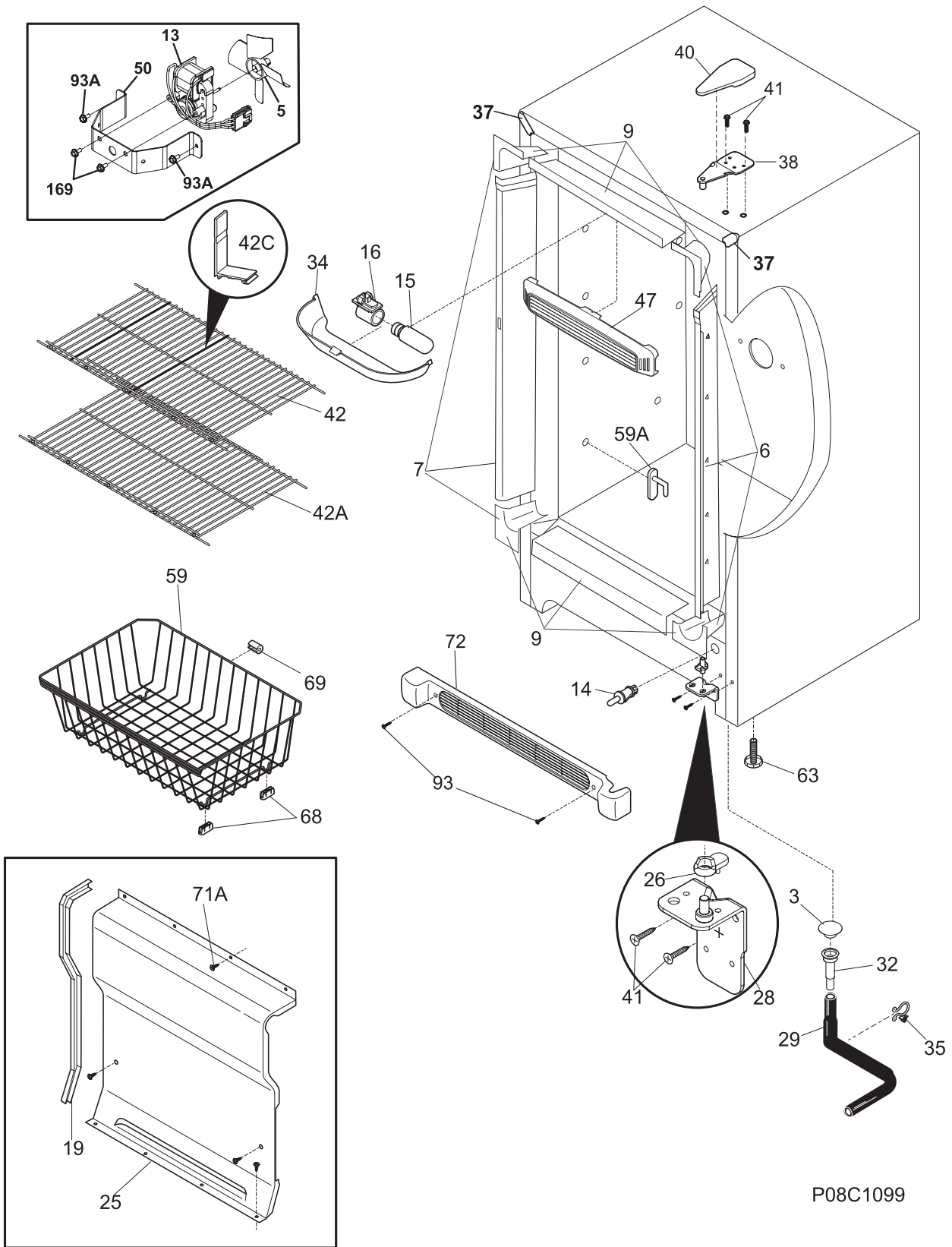

CABINET

POS. NO	PART NO.	DESCRIPTION
3	216503100	Screen-drain
5 #	216325600	Fan Blade
6	297200600	Breaker Kit w/corners, no lock slot
7	297200800	Breaker Kit w/corners, incl lock catch
9	297200100	Breaker Kit w/corners, 32", top and bottom
13	216934100	Motor, fan, 115 V
14	297243801	Switch, light/lamp, black, plunger
15	216846400	Light Bulb/Lamp
16	216817600	Socket, light/lamp, 25 W
19	216204900	Gasket, evap cover
25	297098851	Cover-evaporator
26	216503300	Ramp, door closer
28	297240800	Hinge-bottom, stepped pin
29	216313501	Hose-drain
32	5308005500	Drain
34	297184400	Shield-light
35	216273000	Clip, drain hose
37	241611303	Trim-cabinet corner, black, (2)
38	297164300	Hinge-upper
40	297164401	Cover-upper hinge, black
41	297236200	Screw, tamper proof, 1/4-20 x 5/8
42	216458400	Shelf, 14.50x27.88, (3)
42A	216458200	Shelf, 12.50x27.88, white
*	216502400	Grommet-shelf mtg
42C	297183702	Divider, blue, wire shelf
47	297192900	Baffle, air
50	216394050	Bracket, fan motor mount
59	297210800	Basket
59A	216486500	Stop-basket, (2)
63	216396900	Screw, leveling foot, plastic, adjustable
68	08009560	Glide-basket, (4)
69	5305878546	Bumper-basket, (2)
71A	297146800	Screw, 8-18AB x 0.470, EVAP PANEL
72	297198901	Grille/Kickplate, 32", black
93	5304460605	Screw, ph truss head, 8-18AB x 0.500
93A	216629601	Screw, hex washer head, 10-16 x 0.500, tapping
169	216912401	Screw, hex washer head, 8-32 x 0.500, bracket fan mtr, (2)
*	216795415	Energy Guide
*	5303305324	Paint, touch-up, white
*	297001704	Insulation, 24", drain tube
*	297241400	Label, EZ start guide

SYSTEM

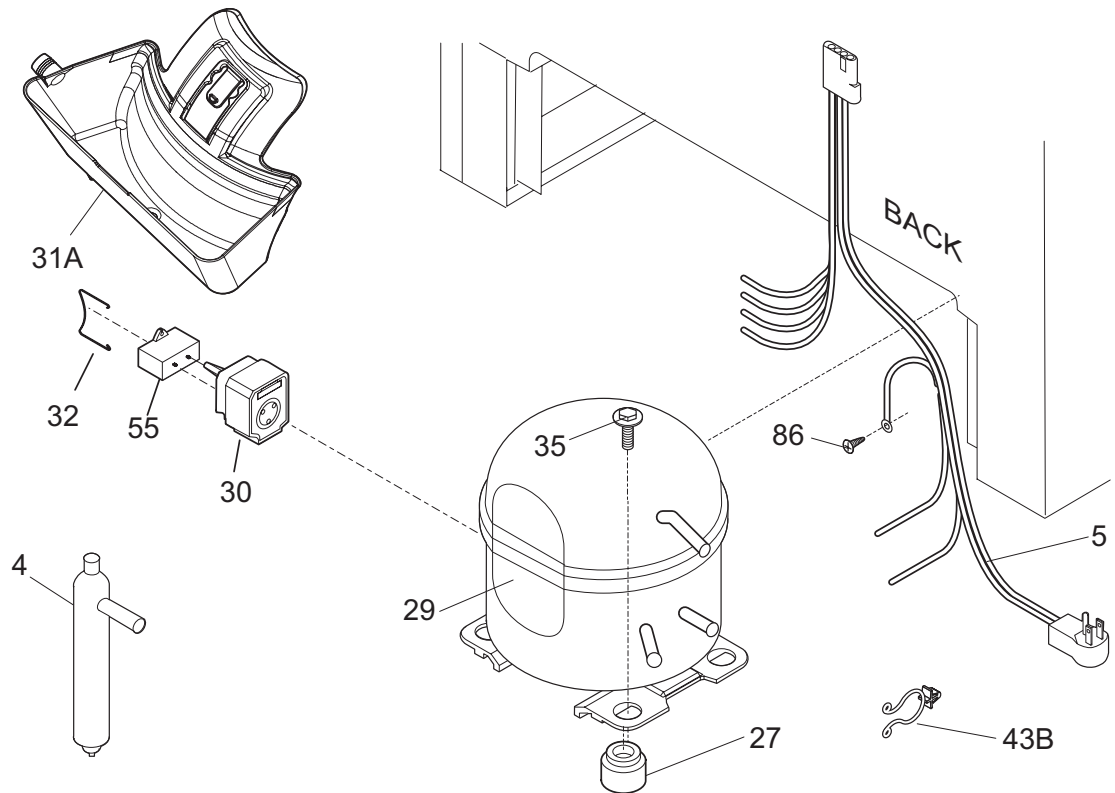
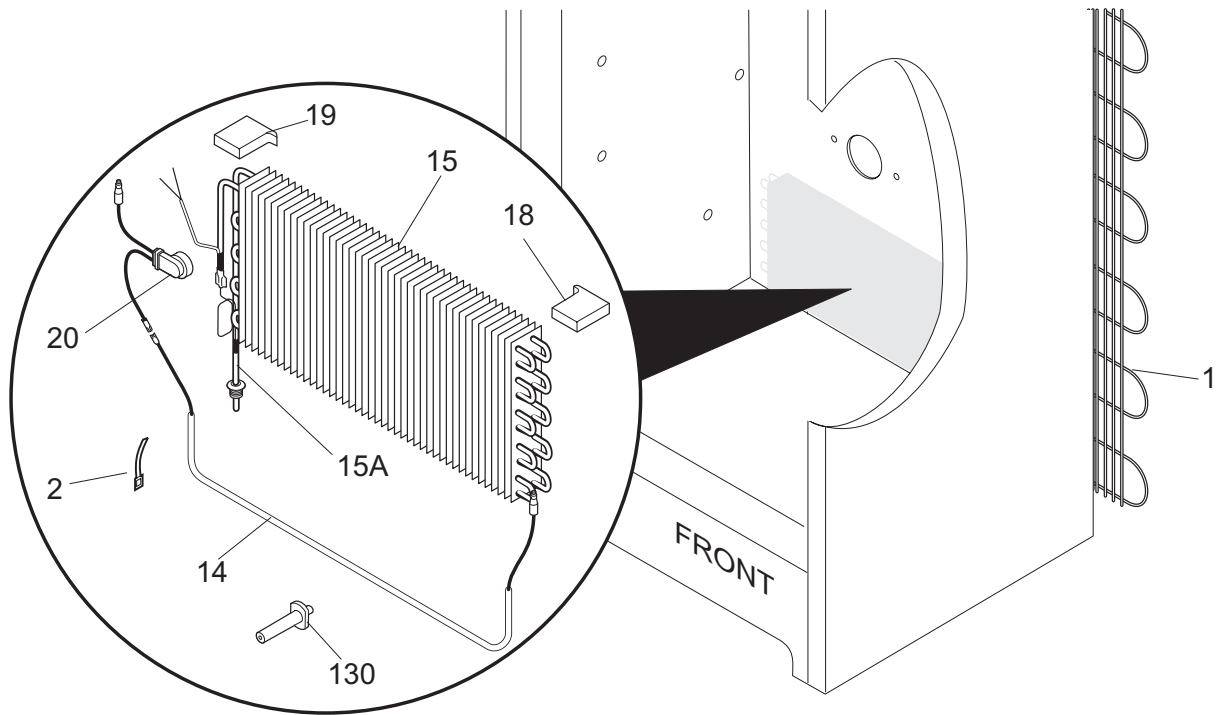

P08S0485

SYSTEM

POS. NO	PART NO.	DESCRIPTION
1 #	5300083897	Condenser
2	5308000110	Strap-evap/heater, aluminum, (2)
4	216987500	Drier-filter
5 #	297237600	Harness-main
14 #	216730700	Heater-defrost
15 #	216997300	Evaporator
15A	297217900	Heat Exchanger, suct/cap tube
18	297078700	Insulator-evap, styrofoam
19	297078800	Insulator-evap, styrofoam
20	216872200	Thermostat, defrost
27	5308002681	Grommet, compressor
29#	297223700	Compressor, w/grommets, w/o electricals
30	216954216	Controller, compressor
31A	297231900	Pan-drain
32	216954300	Clip, controller
35	240491503	Screw-compressor mtg, 1/4-28 x 1.16, (4)
43B	297048400	Clip
55 #	218909912	Capacitor, run, 220 VAC, 12 microfarad
86	216036601	Screw, RWHD, 8-32A x 0.500, GX-CA
130	297244700	Support, evaporator mtg
*	216502500	Sleeve, suction line
*	240555002	Screw-#8-32 X 3/8
*	297014500	Plug-suction line
*	297018400	Thermistor
*	297102800	Spacer-tube
* #	297169900	Cord-power, flat