

52C and 52P  
SERIES

**OWNER'S MANUAL**  
**PACKAGED TERMINAL AIR CONDITIONERS**  
**AND HEAT PUMPS**  
**7,000-15,000 Btuh**

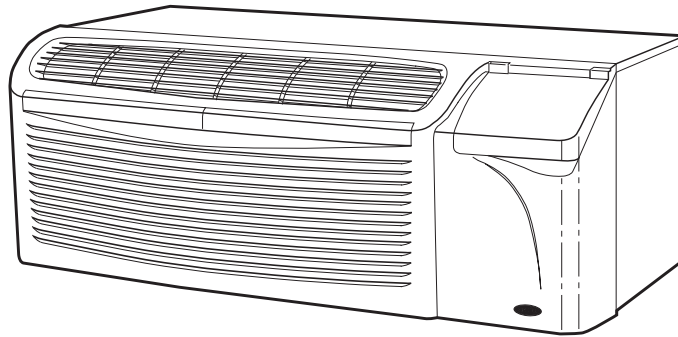

**CONTENTS**

	Page		Page
<b>GENERAL</b> .....	2	<b>CARE AND MAINTENANCE</b> .....	11,12
<b>UNIT INSPECTION</b> .....	2,3	INDOOR-AIR INLET FILTERS .....	11
FRONT PANEL .....	2	EXTERNAL PARTS .....	12
<b>ELECTRICAL DATA</b> .....	4	INTERNAL PARTS .....	12
ALL UNITS .....	4	<b>PREVENTATIVE MAINTENANCE</b> .....	13
VOLTAGE SUPPLY .....	4	<b>TROUBLESHOOTING</b> .....	13
<b>INSTALLATION</b> .....	5-8	<b>ACCESSORIES</b> .....	14
CHASSIS INSTALLATION .....	5		
WALL THERMOSTAT INSTALLATION .....	8		
<b>OPERATION</b> .....	9,10		
COMFORT CONTROLS .....	9		
OPERATING CONTROLS .....	10		
OPERATING MODES .....	10		

**1•800•894•6449** (in USA and Canada)  
For Service/Technical Assistance  
**1•800•830•8600** (Mexico)



Manufacturer reserves the right to discontinue, or change at any time, specifications or designs without notice and without incurring obligations.

# GENERAL

Thank you for choosing Carrier! You can feel confident in your selection because the same pride in craftsmanship and engineering knowledge that goes into Carrier equipment at the Astrodome in Texas, the Sistine Chapel in Rome, the US Capitol Hall of Congress, and thousands of other installations worldwide has gone into the construction of this unit.

The Carrier package terminal air conditioners and heat pumps provide a high standard of quality in performance, workmanship, durability and appearance as they heat and cool the occupied air space year round.

This manual provides information for ease of installation, operation and maintenance of the 52C and 52P units. The following units are covered in this manual (see Figure 1 for additional unit information):

- 52CE 60 Hz cooling with electric heat units
- 52CQ 60 Hz cooling, electric heat, and heat pump units
- 52PE 60 Hz cooling with electric heat units
- 52PQ 60 Hz cooling, electric heat, and heat pump units
- 52PC 60 Hz cooling only units

All models are designed for through-the-wall installation. Separate installation instructions are included

with all accessory components. See Accessories section on page 14 for complete listing of accessories.

# UNIT INSPECTION

Examine unit for damage incurred during shipment. File a claim immediately with the transit company if damage is found.

The data information plate (Figure 1) lists the model number, voltage ranges, and other important electrical information about this product. Reading and understanding this material is important for proper use of this unit. To access the information plate, the front panel must be removed; see Figure 2.

## FRONT PANEL

To remove the front panel:

1. Grasp panel firmly near bottom of both sides.
2. Pull panel forward then upward to release magnetic latches and partition hooks.

NOTE: Front panel may be secured to chassis with 2 screws located behind indoor air inlet filters. In order to remove these screws, the filters must be removed first. Refer to page 10 in this manual for instructions on removing indoor air inlet filters.

**IMPORTANT:** The front panel has to be off the unit to complete future checks and installation procedures. **Do not reinstall front panel at this time.**

Using Figures 1 and 3 as reference, verify that the packaged terminal product ordered will operate properly in your facility. If you do not understand the information given or have questions about the product, please call your local dealer or distributor.

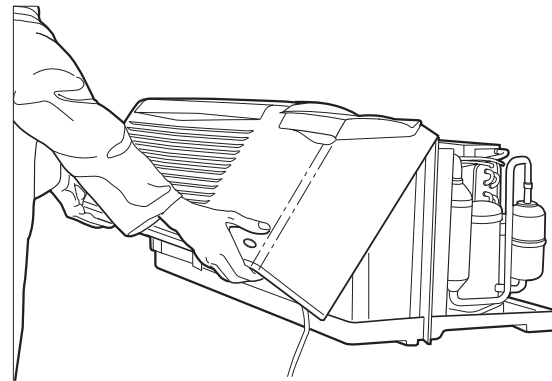

FIGURE 2 — REMOVING FRONT PANEL

Replacement Package Terminal Air Conditioner, CLASSIFIED BY UNDERWRITERS LABORATORIES INC., AS TO ELECTRIC SHOCK, FIRE AND CASUALTY HAZARDS ONLY. FOR FIELD INSTALLATION WITH EXISTING WALL SLEEVES, OUTDOOR LOUVERS, AND INDOOR PANELS AS SPECIFIED ON THE PRODUCT.



MODEL	52PQA312301AA		
SERIAL	3701X11520		
DATE OF MFG.	09/12/2001		
VOLT RANGE	187-253		
VOLTS	230/208		
PH	1	HZ	60
MIN CKT AMPACITY	19.3		
R-22 OZ	34		
DESIGN PSIG	350 HIGH SIDE, 150 LOW SIDE		
<b>COOLING</b>			
BTU/HR	12,100/12,000		
AMPS	4.8/5.3		
WATTS	1100/1100		
EER	11.0/10.9		
COMP	RLA	6.1	
	LRA	29	
FAN	FLA	0.75	
MOTOR	HP	1/8	
<b>HEATING</b>			
BTU/HR	10,800/10,700		
AMPS	15.6/14.5		
WATTS	3570/2997		
COP	3.2/3.2		
HEATER	AMPS	14.8/13.7	
	WATTS	3400/2850	
BTU/HR	WATER		
	STEAM		
USE	20 AMP	CANADIAN INSTALLATION	
TIME DELAY FUSE		MAX FUSE	MAX BREAKER
OR HACR TYPE	20 AMP	20 AMP	
CIRCUIT BREAKER			
* ABOVE DATA FOR PERMANENTLY CONNECTED UNIT ONLY			
MOTOR - COMPRESSOR THERMALLY PROTECTED			
LISTED PACKAGE TERMINAL AIR CONDITIONER		CARRIER Competition	
MADE IN MEXICO 99LR520212 REV D			
FOR SERVICE/TECHNICAL ASSISTANCE IN THE U.S. & CANADA TELEPHONE			
<b>1-800-894-6449</b>			
IN MEXICO TELEPHONE			
<b>01-800-830-8600</b>			

FIGURE 1 — SAMPLE DATA INFORMATION PLATE

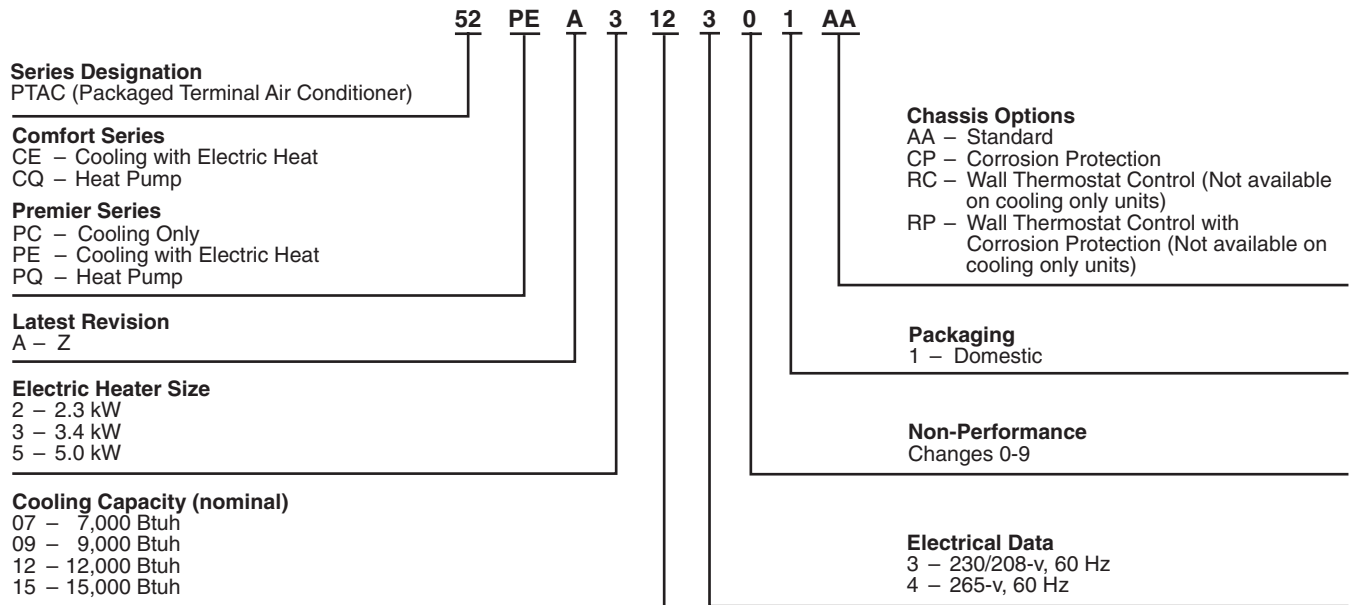

**FIGURE 3 — MODEL NUMBER NOMENCLATURE**

To install the front panel follow the procedure outlined below:

1. Firmly grasp bottom of front panel on both sides.
2. Hold front panel at a 45 degree angle to unit. Be sure front panel is centered with front of unit.
3. Connect top of front panel to partition rail on top of unit.
4. Gently lower front panel onto chassis, ensuring service cord is positioned through front panel slot.

NOTE: Magnets on bottom of front panel will secure front panel to unit.

To install locking feature on front panel be sure front panel is already installed on unit and follow the steps below:

NOTE: Two field-supplied no. 8, 1/2 in. sheet metal screws are required to secure front panel to chassis.

1. Remove both indoor air inlet filters to expose front panel engagement holes. See Figure 4.
2. Secure front panel to chassis by attaching the field-supplied screws into engagement holes. *Do not over tighten.*
3. Replace both indoor air inlet filters.

NOTE: Front panel alignment may have to be adjusted slightly to line with chassis.

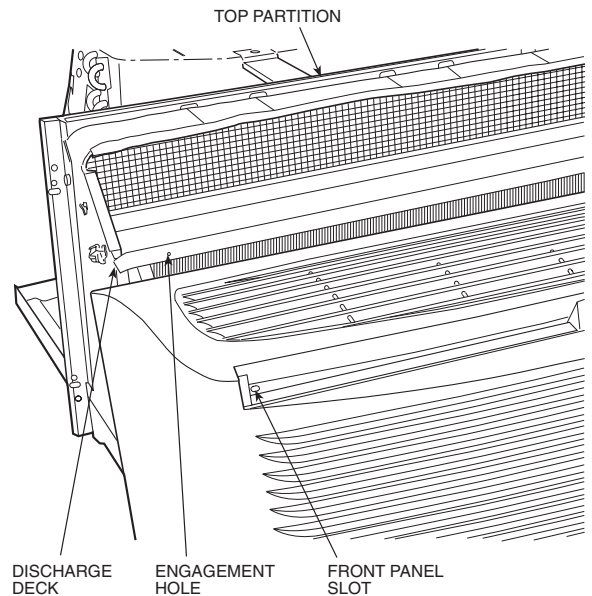

**FIGURE 4 — FRONT PANEL INSTALLATION WITH LOCKING FEATURE**

# ELECTRICAL DATA

## ⚠ WARNING

### ELECTRICAL SHOCK HAZARD

DO NOT alter cord or plug, and DO NOT use an extension cord. Personal injury or damage to the unit may result.

Be sure that your outlet matches the appropriate blade configuration of the supplied plug and that it is within reach of the service cord. A hardwire kit is available as an accessory to change cord-connected units to hardwired units. (See Accessories table on page 14.)

**IMPORTANT:** All standard cord-connected 265-v units will require a field-installed electrical sub-base accessory.

## ALL UNITS

■ **WIRE SIZE** — Use recommended wire size given in Table 1 and install a single branch circuit. All wiring must comply with local and national codes. **All units are designed to operate off single branch circuits only.**

NOTE: Use copper conductors only.

■ **GROUNDING** — For safety and protection, the unit is grounded through the service cord plug or through separate ground wire provided on hardwired units. Be sure that the branch circuit or general purpose outlet is grounded.

**TABLE 1 — SUGGESTED BRANCH CIRCUIT WIRE SIZES\***

NAMEPLATE AMPS	AWG WIRE SIZE†
7.0 to 12	14
12.1 to 16	12
16.1 to 24	10

### LEGEND

AWG — American Wire Gage

\*Single circuit from main box.







†Based on copper wire at 60 C temperature rating.

## VOLTAGE SUPPLY

Check voltage supply at outlet. For satisfactory results, the voltage range must always be within the ranges found on the data information plate (Figure 1).

■ **CORD-CONNECTED UNITS** — The 250-v field-supplied outlet must match the plug for the standard 208/230-v units and be within reach of the service cord. The standard cord-connected 265-v units require an accessory electrical subbase for operation. See Accessories table, page 14, for subbase selection. Refer to Table 2 for proper receptacle and fuse type.

**TABLE 2 — RECEPTACLES AND FUSE TYPES — 250,265 VOLTS**

RECEPTACLE						
	15 Amps	20 Amps	30 Amps	15 Amps	20 Amps	30 Amps
RATED VOLTS	250	250	250	265	265	265
TIME-DELAY TYPE FUSE (or HACR Circuit Breaker)	15	20*	30	15	20	30

### LEGEND

HACR — Heating, Air Conditioning, Refrigeration

\*May be used for 15-amp applications if fused for 15 amp.

# INSTALLATION

## CHASSIS INSTALLATION

Units are shipped without a sleeve. In applications where unit is a replacement, it is recommended that a Carrier sleeve be used.

The 52C and 52P units can retrofit General Electric, Amana, Trane, and Friedrich sleeves/grilles (be sure outdoor grille is installed on the sleeve). See Table 3 for details. Carrier Corporation must approve any other retrofit application.

For competitive retrofit applications, be sure that the foam seals (factory-installed on the tube sheets) provide a good seal between the grille and outdoor coil tube sheets. These foam seals provide a barrier to separate outdoor coil leaving air from mixing with the outdoor incoming air (known as air recirculation). See Figure 5.

**⚠ CAUTION**  
For retrofit applications, foam seals on outdoor coil tube sheets must make a seal between the coil and the grille or loss of performance and premature damage to the major components can result.

**TABLE 3 — RETROFIT WALL SLEEVES**

MANUFACTURER	WALL SLEEVE PART NUMBER
General Electric	Metal Sleeve RAB71
	Plastic Sleeve RAB77
Amana	Metal Sleeve WS900B
Trane	Metal Sleeve SLV149
Friedrich	T-Series Metal 11½-in. deep wall sleeve*
	Standard depth wall sleeve 16 x 42 x 13¾-in. PXWS

\*FR-SLEEVE-EXT accessory is required for retrofit into Friedrich (T-Series) wall sleeves.

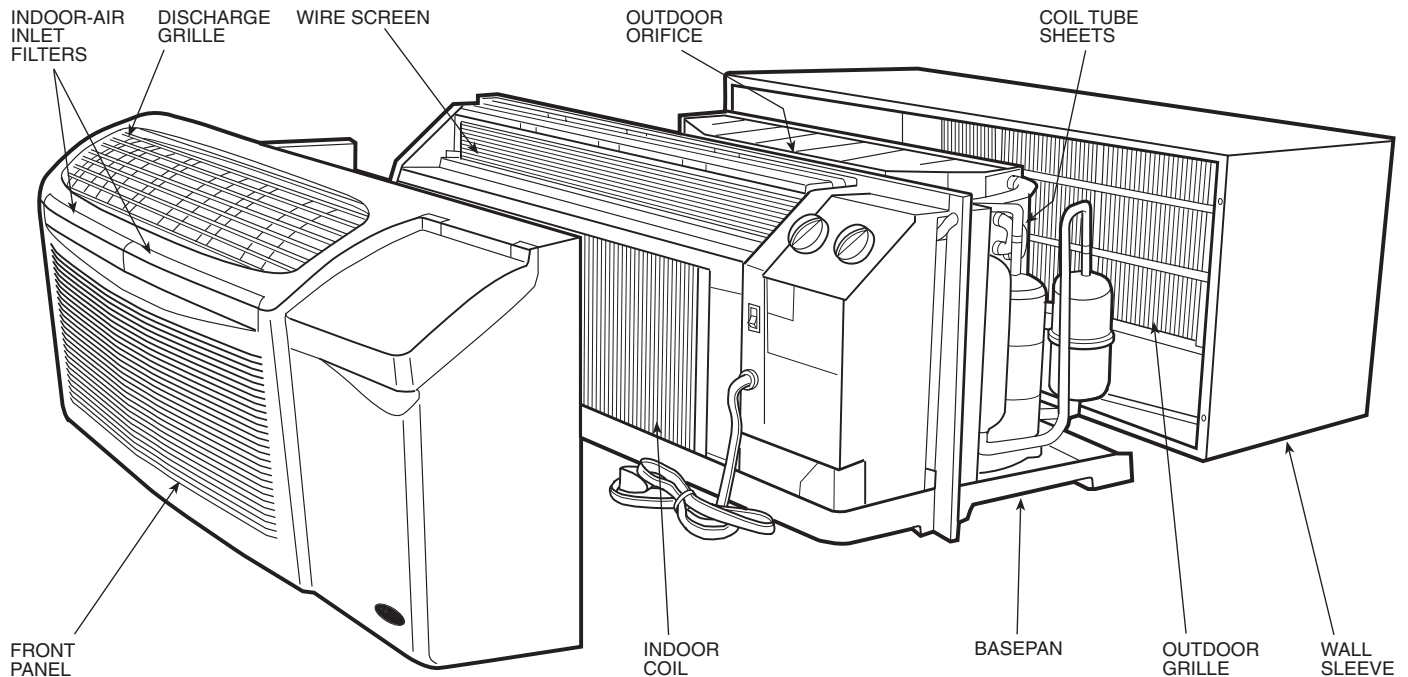

**FIGURE 5 — UNIT COMPONENTS**

■ **RETROFIT SLEEVE PREPARATION**

**IMPORTANT:** Inspect the wall sleeve thoroughly prior to installation. Manufacturer does not assume responsibility for costs or damages due to defects in the sleeve or improper installation.

**⚠ WARNING**

Disconnect all power to unit to avoid possible electrical shock during installation.

Remove any existing foam baffles that are installed on the outdoor grille if present. See Figure 6.

GE Sleeves Only

**Metal Wall Sleeve** — Remove metal clip on mounting rail located on left, inside bottom of metal sleeve and discard. See Figure 7.

**Plastic Sleeve** — Remove bottom seal from plastic sleeve. See Figure 8.

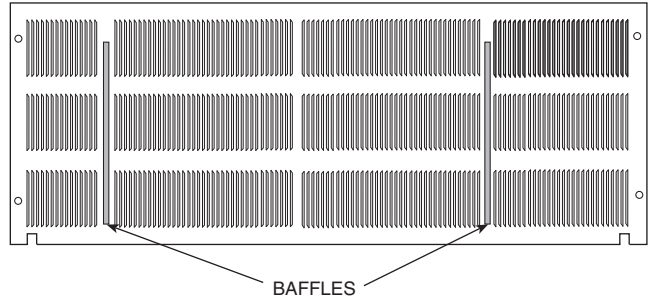

**FIGURE 6 — REMOVE EXISTING OUTDOOR GRILLE BAFFLES**

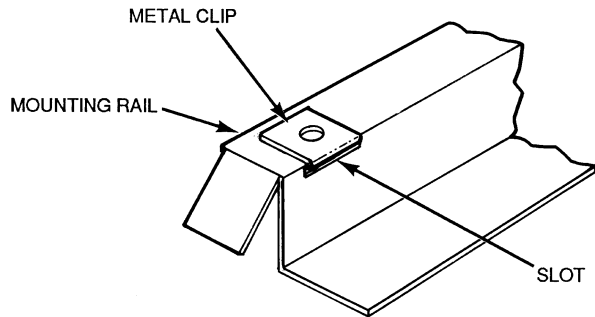

**FIGURE 7 — REMOVE METAL CLIP ON GE METAL SLEEVE**

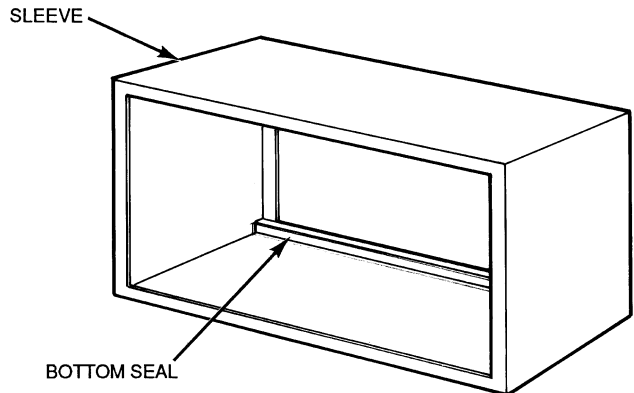

**FIGURE 8 — REMOVE BOTTOM SEAL FROM GE PLASTIC SLEEVE**

■ **INSTALL CHASSIS IN SLEEVE (See Figures 9 to 11)**

1. Inspect foam gaskets (top, bottom, both sides) on chassis. Replace foam gaskets if torn or missing.

**IMPORTANT:** The gaskets combine with the sleeve face to create a weather barrier. If the chassis is installed in a non-Carrier sleeve, this weather barrier may not be effective.

**▲ WARNING**  
Chassis weighs up to 150 lbs. For personal protection, seek help when lifting the unit. Lift unit by holding unit basepan.

2. If retrofitting into a GE, Amana, Trane, or Friedrich wall sleeve/grille, remove any existing foam seals from competitive manufacturer's grille before installing unit.
3. Remove shipping tape from vent door. See Figure 9.

**▲ CAUTION**  
Failure to remove shipping tape will prevent fresh air vent door from opening and may result in damage to the vent door cable.

4. Lift chassis level with wall sleeve.
5. Slide chassis into wall sleeve until foam gaskets rest firmly against front of wall sleeve. See Figure 10.
6. Screw chassis to wall sleeve with four 1<sup>3</sup>/<sub>4</sub>-in. long screws taped to the control box. Screw holes are located on both sides of the mounting angles of the chassis. For Carrier wall sleeves, use the top-most and bottom-most screw holes. For competitive wall sleeves, line up the correct attachment holes on the chassis with the holes in the sleeves. See Figure 11.

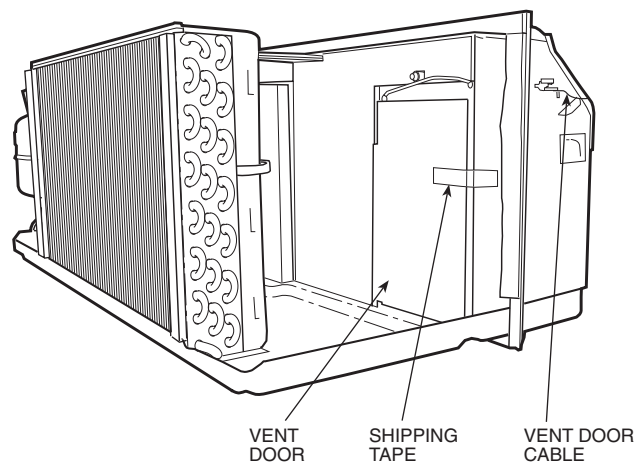

**FIGURE 9 — LOCATION OF SHIPPING TAPE ON VENT DOOR**

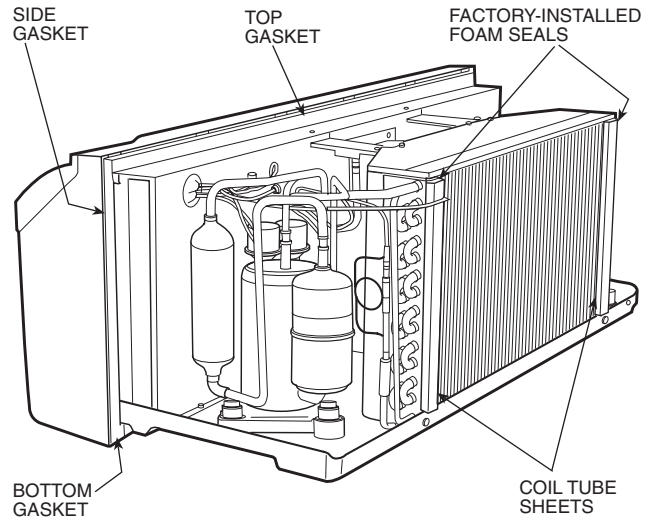

**FIGURE 10 — UNIT GASKETS AND TUBE SHEETS**

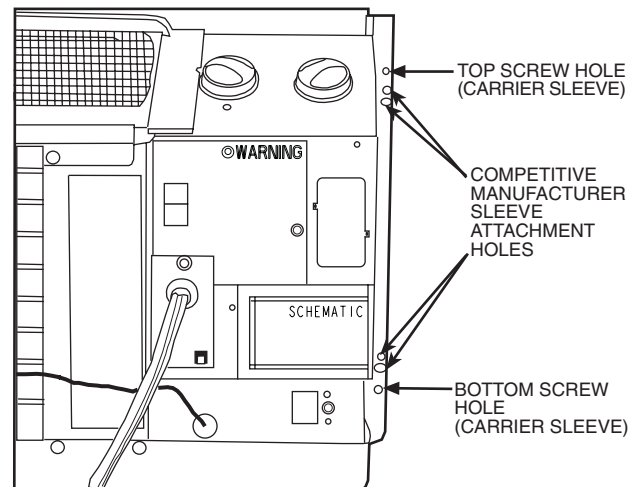

**FIGURE 11 — CHASSIS MOUNTING**

## WALL THERMOSTAT INSTALLATION

The following instructions apply to RC and RP units only.

NOTE: Carrier thermostats are recommended. See Accessories section.

**IMPORTANT:** Only trained, qualified personnel and service mechanics should install electrical accessories on Carrier 52C and 52P series products per Carrier's installation instructions. Please contact your local electrical contractor, dealer, or distributor for assistance.

### ■ INSTALL THERMOSTAT — All remote control units.

1. Check to be sure power to unit is disconnected.
2. Remove terminal board cover from control box cover by removing screw (see Figure 12).

NOTE: Terminal connector can be removed and replaced to simplify thermostat wiring.

3. Connect wires from terminals on the thermostat to terminals on chassis terminal board connector. See Figures 13 and 14.

4. Reinstall cover.
5. Restore power to unit.

NOTE: Refer to thermostat installation instructions for details on installing thermostat.

NOTE: Fan speed is user-selectable from the control panel on the unit.

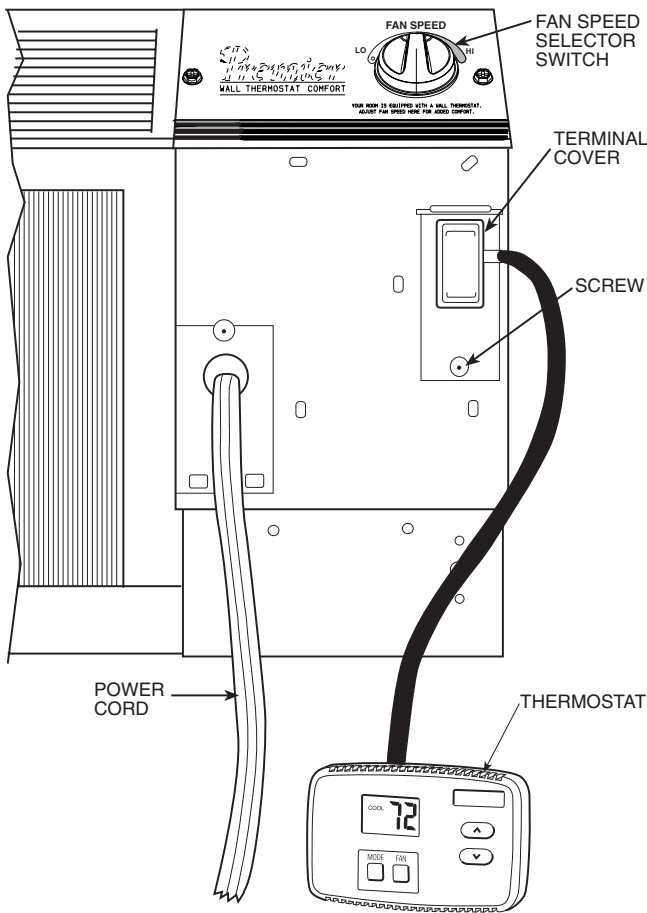

**FIGURE 12 — CONTROL BOX TERMINAL COVER FOR WALL THERMOSTAT MODELS**

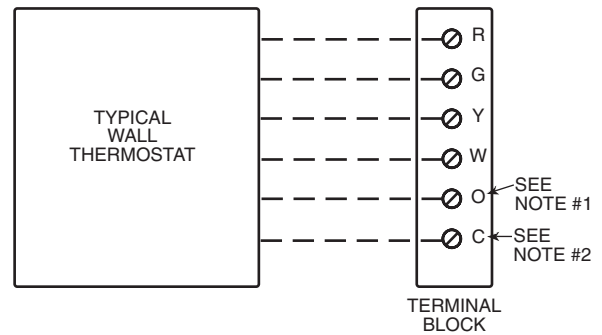

#### NOTES:

1. Use terminal "O" for heat pump connection only.
2. Terminal C (common) typically is only required for digital thermostats.
3. See table below for terminal descriptions.

TERMINAL	DESIGNATION
R	24 VAC
G	Fan
Y	Compressor
W	Electric Heat
O	Reversing Valve
C	Common

**FIGURE 13 — WIRING CONNECTIONS**

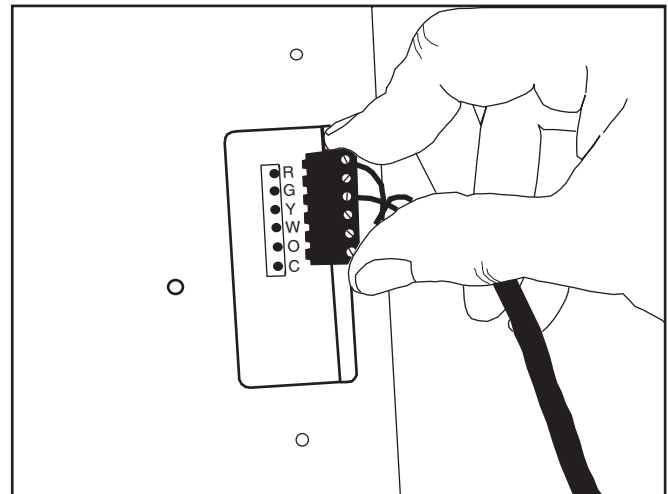

**FIGURE 14 — TERMINAL CONNECTOR REMOVAL AND REPLACEMENT**



# OPERATION

**IMPORTANT:** When unit is first started, high humidity conditions can cause condensation to form on discharge grille. Keep doors and windows closed. Room humidity decreases and moisture evaporates.

## COMFORT CONTROLS

■ **ADJUST AIRFLOW DIRECTION** — The discharge air grille is mounted on the front panel so that the air discharges forward. If upward discharge is required, remove the grille by removing screws on back of front panel. Rotate grille 180 degrees and reinstall on the front panel.

■ **ADJUST VENT** — The vent handle is on the left side of the unit. Turn handle to open or close vent. Vent will remain in last desired position until handle is turned again. Magnet will ensure positive closure. See Figure 15.

■ **SETTING TEMPERATURE LIMITS** — Setting temperature limits on the unit provides the user a restricted range of temperature control. See Figure 16.

**NOTE:** This adjustment is optional and is not applicable to remote control units.

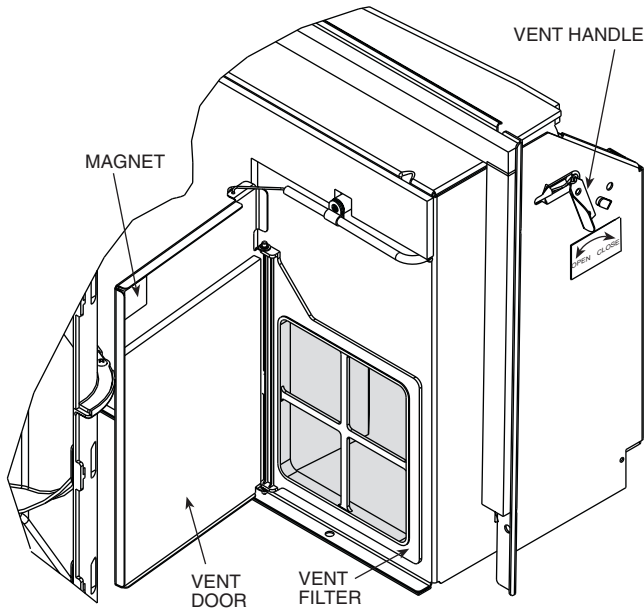
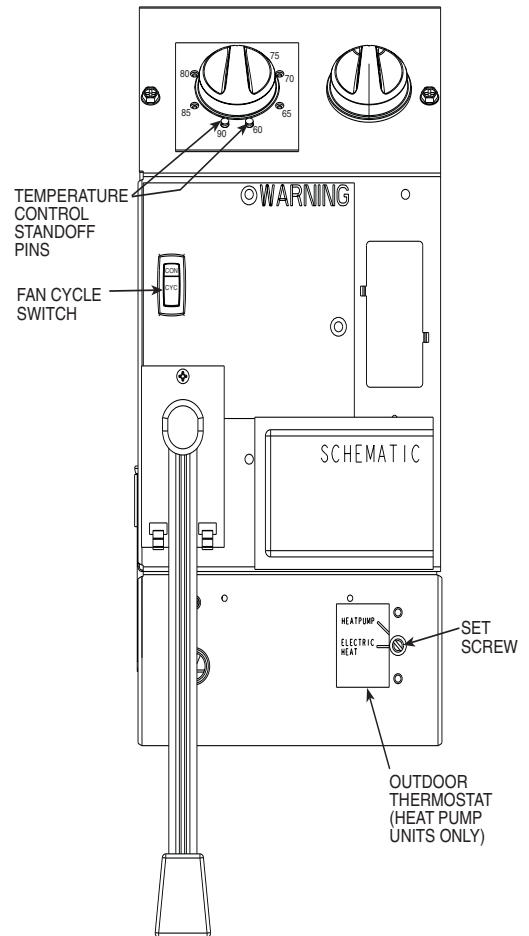

**FIGURE 15 — VENT DOOR**

The temperature limits are factory set to full range, which is 60 F to 90 F. To set restricted rotation of the temperature control knob:

1. Remove front panel.
2. Remove temperature control knob to expose temperature limiter.
3. Remove standoff pins from the 60 F and 90 F indicator holes.
4. Replace standoff pin in hole for desired minimum temperature.
5. Replace standoff pin in hole for desired maximum temperature.
6. Reinstall temperature control knob.
7. Reinstall front panel.

**NOTE:** Temperature indicators stamped on temperature limiter are approximate and represent degrees F.



**FIGURE 16 — OPERATING CONTROLS**

## OPERATING CONTROLS

The following controls are located on the front of the control box door, under front panel. To obtain access to operating controls, remove the unit front panel as shown on page 2. See Figure 16.

■ **FAN CYCLE SWITCH** — (Typically available at wall thermostat on RC or RP units.) This allows the fan to operate in two modes:

**CON (Continuous)** — This setting allows the fan to run continuously, circulating air even when the temperature setting has been satisfied. This switch helps to maintain the room temperature closer to the thermostat setting. Use this switch position when maximum comfort is desired. This is the factory default setting.

**CYC (Cycle)** — This setting allows the fan to cycle on and off with the compressor during heating or cooling. The fan stops when the temperature setting is satisfied. This results in longer unit off-time and wider variations in room temperature and humidity.

■ **OUTDOOR THERMOSTAT (52CQ and 52PQ HEAT PUMP UNITS ONLY)** — If the setscrew is left at the factory setting (in the heat pump position), the unit will operate in the reverse cycle heating mode. See Figure 16. When the temperature of the outdoor coil reaches 20° F (approximately 35° F outdoor air temperature), the compressor will shut down. The electric heater remains on until the temperature of the outdoor coil reaches 40° F; then the electric heater is shut off and the compressor is energized.

To set unit to operate in electric heat mode only, turn the setscrew to the electric heat position. See Figure 16.

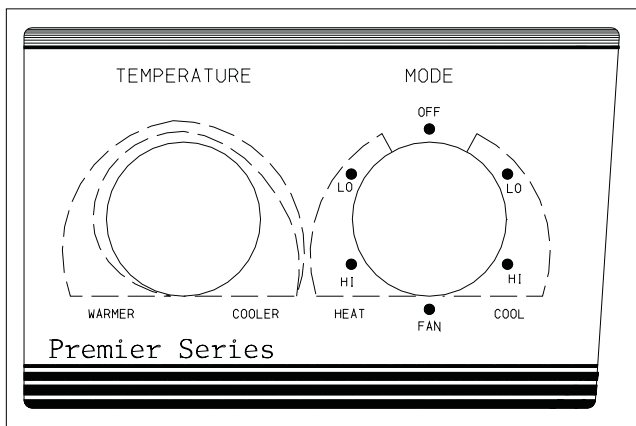

FIGURE 17 — 52P UNIT CONTROLS SHOWN

**IMPORTANT:** If setscrew on standard heat pump unit is set to electric heat mode operation, the compressor is disabled for *both* heating and cooling operations. If setscrew on heat pump unit with wall thermostat control is set to electric heat mode operation, the compressor will be disabled *only* for heating operation.

## OPERATING MODES (See Figures 17 and 18.)

■ **OUTSIDE AIR** — To bring outside air into occupied space, turn the vent handle to the full open position. See Figure 15.

■ **OFF** — The OFF mode terminates unit operation.

■ **FAN** — The FAN mode will circulate air in the space at high speed and at high or low speed for cooling only models.

■ **HIGH HEAT OR HIGH COOL** — Select mode and rotate temperature knob to desired comfort level. This function provides maximum heating or cooling, and is recommended to raise or lower the room temperature quickly.

■ **LOW HEAT OR LOW COOL** — Select mode and rotate temperature knob to desired comfort level. This function provides minimum heating or cooling with maximum dehumidification and quietest operation.

■ **FAN SPEED CONTROL FOR 52P AND 52C WALL THERMOSTAT MODELS** — For maximum comfort, fan speed is user selectable at the unit. See Figure 18.

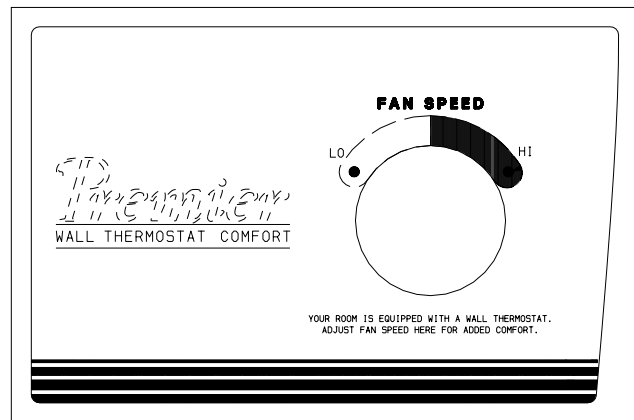

FIGURE 18 — 52P UNIT WITH WALL THERMOSTAT CONTROL SHOWN (Blank Plate)

---

## CARE AND MAINTENANCE

In order to maintain proper performance of your packaged terminal air conditioner or heat pump, it is very important that the fan and outdoor coil, the blower wheel, blower scroll, electric heater, and all drain passages are thoroughly cleaned at least once per year. Carrier recommends that as a minimum, the cleaning should be conducted prior to the start of each heating season. The air inlet filters should be cleaned every month.

Depending on local conditions, more frequent cleaning of the unit may be required to ensure optimum performance and long operating life. Examples of these special conditions include areas where construction dust or heavy airborne dirt is found, or environments that promote the growth of fungus.

### ▲ CAUTION

Some local conditions and environments can cause fungi to grow inside the air conditioner, especially on indoor blower section. Dried fungi, dirt and other foreign material are fire hazards. Be sure to clean unit according to the instructions that follow.

## INDOOR-AIR INLET FILTERS

■ **INDOOR-AIR INLET FILTERS** should be cleaned once each month.

**IMPORTANT:** Filters may become clogged if not cleaned properly. Clogged filters will restrict air-flow which may lead to severe component damage and efficiency loss.

■ **CLEANING INDOOR-AIR INLET FILTER** — Two interchangeable air filters are located on the backside of the front panel. Each can be removed and cleaned one at a time. To remove and clean the filter, follow the steps below:

1. Grasp filter with both hands.
2. Gently pull the filter up and away from the unit. See Figures 5 and 19.
3. To clean filter, use a vacuum or soft bristle brush with a small amount of mild detergent.

**NOTE:** If detergent is used, remove any detergent residual with a gentle stream of clean water.

4. Allow filters to air dry.
5. Re-insert dry filters back into front panel.

Additional filters are available in multi-packs. Refer to Accessories section.

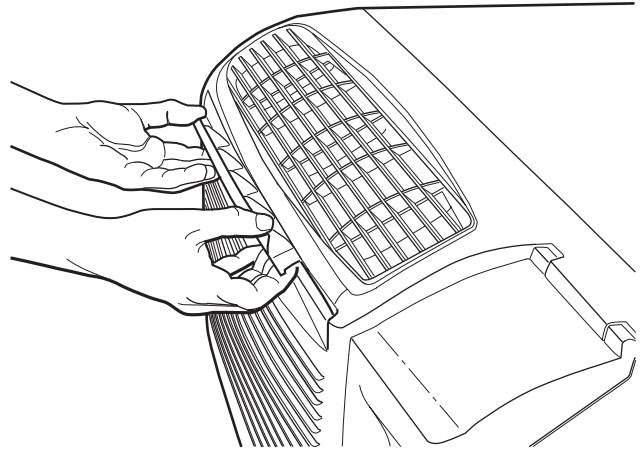

**FIGURE 19 — INDOOR-AIR INLET FILTER REMOVAL**

---

## EXTERNAL PARTS

■ **EXTERNAL PARTS** include the polymer sleeve and grilles. The sleeve manufacturer recommends cleaning the surface, including the grilles, with household detergent and water.

## INTERNAL PARTS

■ **INTERNAL PARTS** should be cleaned at least once during the year. The outdoor vent filter should be cleaned at least once during a cooling or heating season.

Internal parts that should be cleaned include the following (see Figures 5, 20, and 21):

- Outdoor vent filter
- Basepan
- Outdoor orifice and fan
- Indoor and outdoor refrigeration coils
- Indoor blower wheel
- Wire screen
- Scroll
- Wall sleeve internal surfaces
- Outdoor grille

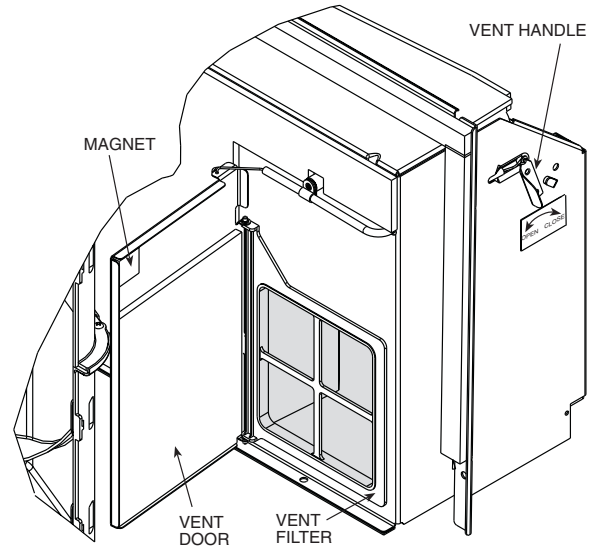

**FIGURE 20 — OUTDOOR VENT FILTER  
(Left Side of Chassis)**

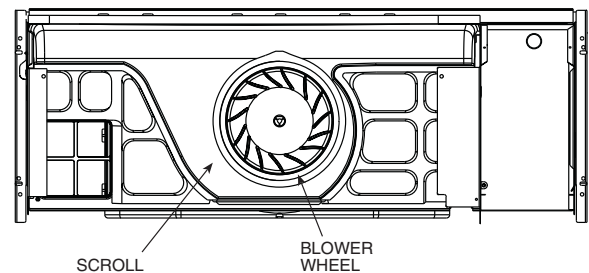

**FIGURE 21 — BLOWER WHEEL AND SCROLL**

# PREVENTATIVE MAINTENANCE

Preventative maintenance is essential to proper unit operation, efficiency and longevity. To assure equipment operates properly it must be properly maintained. Equipment operation should be checked and verified several times during each year.

During regular unit inspection and maintenance, follow the guidelines below:

- Wash both sides of outdoor coil
- Wash basepan and outdoor vent filter
- Wash the indoor coil
- Clean the blower wheel and front panel
- Clean or install new indoor-air inlet filter(s)
- Ensure knobs are secure and operable
- Inspect cord and receptacle
- Secure electrical connections
- Ensure front panel is properly mounted and not damaged
- Ensure wall sleeve is installed properly
- Ensure heat and cool cycles operate properly

## TROUBLESHOOTING

POSSIBLE CAUSES	SOLUTIONS
<b>UNIT DOES NOT START</b> <ul style="list-style-type: none"> <li>• Unit may have become unplugged</li> <li>• Fuse may have blown</li> <li>• Circuit breaker may have been tripped</li> <li>• Unit mode dial may be set to the OFF position</li> </ul>	<ul style="list-style-type: none"> <li>• Check that plug is securely in wall receptacle.</li> <li>• Replace the fuse. See Note 1.</li> <li>• Reset circuit breaker. See Note 1.</li> <li>• Switch mode dial to an operating mode.</li> </ul>
<b>UNIT NOT COOLING/HEATING ROOM</b> <ul style="list-style-type: none"> <li>• Unit air discharge section is blocked</li> <li>• Temperature setting is not high or low enough</li> <li>• Unit air filters are dirty</li> <li>• Room is excessively hot or cold when unit is started</li> <li>• Vent door left open</li> </ul>	<ul style="list-style-type: none"> <li>• Make sure that curtains, blinds or furniture are not restricting or blocking unit airflow.</li> <li>• Reset to a lower or higher temperature setting.</li> <li>• Remove and clean filters.</li> <li>• Allow sufficient amount of time for unit to heat or cool the room. Start heating or cooling early before outdoor temperature, cooking heat or gatherings of people make room uncomfortable.</li> <li>• Close vent door.</li> </ul>
<b>UNIT MAKING NOISES</b>	<ul style="list-style-type: none"> <li>• Clicking, gurgling and whooshing noises are normal during operation of unit.</li> </ul>
<b>WATER DRIPPING OUTSIDE</b>	<ul style="list-style-type: none"> <li>• If a drain kit has not been installed, condensation run-off during very hot and humid weather is normal. See Note 2. If a drain kit has been installed and is connected to a drain system, check gaskets and fittings around drain for leaks and plugs.</li> </ul>
<b>WATER DRIPPING INSIDE</b> <ul style="list-style-type: none"> <li>• Wall sleeve is not installed level</li> </ul>	<ul style="list-style-type: none"> <li>• Wall sleeve must be installed level for proper drainage of condensation. Check that installation is level and make any necessary adjustments.</li> </ul>
<b>ICE OR FROST FORMS ON INDOOR COIL</b> <ul style="list-style-type: none"> <li>• Low outdoor temperature</li> <li>• Dirty filters</li> </ul>	<ul style="list-style-type: none"> <li>• When outdoor temperature is approximately 55 F or below, frost may form on the indoor coil when unit is in Cooling mode. Switch unit to FAN operation until ice or frost melts.</li> <li>• Remove and clean filters.</li> </ul>

**NOTES:**

1. If circuit breaker is tripped or fuse is blown more than once, contact a qualified electrician.
2. If unit is installed where condensation drainage could drip in an undesirable location, an accessory drain kit should be installed and connected to drain system.



# ACCESSORIES

ACCESSORY	FORM NUMBER	PART NUMBER	DESCRIPTION
Wall Sleeves	52S-48SI	WALL-SLEEVE-1PK WALL-SLEEVE-9PK SLEEVE-INSUL-1PK	Non-Insulated Polymer Wall Sleeve, 1 per pack Non-Insulated Polymer Wall Sleeve, 9 per pack Insulated Polymer Wall Sleeve, 1 per pack
	52S-50SI	SLEEVE-STEEL-1PK	Insulated Metal Wall Sleeve, 1 per pack
	52S-49SI	SLEEVE-EXT24-1PK SLEEVE-EXT26-1PK SLEEVE-EXT28-1PK SLEEVE-MOLDING	Extended Metal Wall Sleeve for Deep Wall Applications (24 in. deep), 1 per pack Extended Metal Wall Sleeve for Deep Wall Applications (26 in. deep), 1 per pack Extended Metal Wall Sleeve for Deep Wall Applications (28 in. deep), 1 per pack Molding kit to trim the wall sleeve to the wall
	52C,P-20SI	FR-SLEEVE-EXT	Friedrich wall sleeve extension to retrofit Carrier PTAC unit into Friedrich 11 <sup>1</sup> / <sub>2</sub> " deep (T Series) wall sleeve. 1 per pack
	Exterior Grilles*	52S-59SI	GRILLE-ALU-STAMP
52S-58SI		GRILLE-PLA-ALPIN GRILLE-PLA-BROWN GRILLE-PLA-BEIGE	Polymer Architectural Rear Grille, Alpine (matches Carrier Wall Sleeve) Polymer Architectural Rear Grille, Brown Polymer Architectural Rear Grille, Beige
52S-60SI		GRILLE-ALU-CLEAR GRILLE-ALU-WHITE GRILLE-ALU-BRONZ GRILLE-ALU-MBRNZ GRILLE-ALU-BROWN GRILLE-ALU-BEIGE GRILLE-ALU-ALPIN GRILLE-ALU-PEACH GRILLE-ALU-MELON GRILLE-ALU-LGREY GRILLE-ALU-SGREY GRILLE-ALU-RDBRK GRILLE-ALU-BLUE GRILLE-ALU-GREEN	Aluminum Architectural Exterior Grille, Clear Finish Aluminum Architectural Exterior Grille, White Aluminum Architectural Exterior Grille, Light Bronze Aluminum Architectural Exterior Grille, Medium Bronze Aluminum Architectural Exterior Grille, Brown (Dark Bronze) Aluminum Architectural Exterior Grille, Beige Aluminum Architectural Exterior Grille, Alpine (matches Carrier Wall Sleeve) Aluminum Architectural Exterior Grille, Peach Aluminum Architectural Exterior Grille, Melon Aluminum Architectural Exterior Grille, Light Grey Aluminum Architectural Exterior Grille, Slate Gray Aluminum Architectural Exterior Grille, Red Brick Aluminum Architectural Exterior Grille, Blue Aluminum Architectural Exterior Grille, Green
52C,P-1SI		SUBBASE-NON-ELEC	Non-electrical Subbase
52C,P-2SI		SUBBASE-230V-15A SUBBASE-230V-20A SUBBASE-230V-30A	Electrical subbase with factory-installed 208/230V, 15 amp receptacle Electrical subbase with factory-installed 208/230V, 20 amp receptacle Electrical subbase with factory-installed 208/230V, 30 amp receptacle
Subbase	52C,P-17SI	SUBBASE-265V-15A SUBBASE-265V-20A SUBBASE-265V-30A	Electrical subbase with factory-installed 265V, 15 amp receptacle Electrical subbase with factory-installed 265V, 20 amp receptacle Electrical subbase with factory-installed 265V, 30 amp receptacle
	52C,P-3SI	SUBBASE-HARDWIRE	Electrical subbase with factory-installed hardwire kit (230/208V and 265V)
Subbase Field-Installed Kits	52C,P-4SI	SUBBASE-SWITCH	Field-Installable Switch kit for an electrical subbase
	52C,P-5SI	SUBBASE-FUSE-15A SUBBASE-FUSE-20A SUBBASE-FUSE-30A	Field-Installed Fuse Kit (15 amp) for electrical subbase Field-Installed Fuse Kit (20 amp) for electrical subbase Field-Installed Fuse Kit (30 amp) for electrical subbase
Electrical Connections	52C,P-11SI	HARDWIRE-KIT-1PK	Permanent power connection to the unit (includes 36" of flexible conduit and unit-mounted connector, 230/208V and 265V) 1 per pack
	52C,P-19SI	CONDUIT-INTF-4PK	Interface kit for field-supplied conduit to provide permanent power connection (230/208V and 265V) to the unit. Kit includes Molex connector for easy connect/disconnect. 4 per pack
Condensate Drain Kit	52S-53SI	DRAIN-KIT-4PK	Attaches to wall sleeve for controlled internal or external disposal of condensate 4 per pack
Wall Thermostats	N/A	HH01AD045 TSTATCCBPC01-B TSTATCCBPH01-B TSTATCCPA01-B TSTATCCPH01-B	Electro-mechanical Wall Thermostat (Heat/Cool and Heat Pump) Value Series Electronic Thermostat w/Digital display (Heat/Cool Models) Value Series Electronic Thermostat w/Digital display (Heat Pump Models) 7-Day Programmable Electronic Thermostat (Heat/Cool Models) 7-Day Programmable Electronic Thermostat (Heat Pump Models)
Wall Thermostat Interface Retrofit Kit	52C,P-7SI	RC-FIELDKIT230HC RC-FIELDKIT230HP RC-FIELDKIT265HC RC-FIELDKIT265HP	Field-installed wall thermostat retrofit kit to convert a standard 230V Heat/Cool unit to an RC unit. Wall thermostat sold separately (can be used to convert a cool only unit to RC). Field-installed wall thermostat retrofit kit to convert a standard 230V Heat Pump unit to an RC unit. Wall thermostat sold separately. Field-installed wall thermostat retrofit kit to convert a standard 265V Heat/Cool unit to an RC unit. Wall thermostat sold separately (can be used to convert a cool only unit to RC). Field-installed wall thermostat retrofit kit to convert a standard 265V Heat Pump unit to a RC unit. Wall thermostat sold separately.
	N/A	2SPEED-TSTAT-KIT	Field-installed automatic heat/cool changeover thermostat with 2-speed fan control at thermostat.
	N/A	TSTATCOVER-6X7	Clear plastic locking thermostat cover prevents unauthorized access to thermostat. Cover for use with non-programmable and electro-mechanical thermostats. Outside dimensions: 6 <sup>1</sup> / <sub>2</sub> " x 7 <sup>1</sup> / <sub>2</sub> " x 2 <sup>1</sup> / <sub>8</sub> ". 1 per pack
	N/A	TSTATCOVER-7X10	Clear plastic locking thermostat cover prevents unauthorized access to thermostat. Cover for use with programmable thermostats. Outside dimensions: 7 <sup>1</sup> / <sub>4</sub> " x 9 <sup>3</sup> / <sub>4</sub> " x 3 <sup>3</sup> / <sub>8</sub> ". 1 per pack
	Replacement Filters	N/A	AIR-FILTER-10PK
Energy Management	52C,P-10SI	EM-KIT	Allows unit to be turned on and off from a remote location (includes freeze guard protection)
Locking Security Control Door	52C,P-13SI	SECURITY-DOOR	Key-locking security door to prevent access to heating and cooling controls
Lateral Duct Kit	52C,P-14SI	LATERAL-DUCT	Ductwork to allow one unit to heat and cool two rooms (plenum plus extension duct and registers)
Power Fresh Air Vent	N/A	PWR-VENT-DOOR230 PWR-VENT-DOOR265	Power vent with automatic door that opens and closes when the fan turns on and off.(230V) Power vent with automatic door that opens and closes when the fan turns on and off. (265V)
Air/Curtain Deflector	52C,P-9SI	DEFLECTOR-1PK	Lateral air deflector, with individually adjustable louvers, to enhance air circulation, 1 per pack
	52C,P-21SI	CURTDL-52CP-1PK	Curtain deflector for 52C and 52P models — prevents curtains from blowing into discharge air stream. 1 per pack. NOTE: Curtain deflector for previous models are also available. Contact Carrier Representative.
Touch-Up Paint	N/A	CARRIER-TOUCH-UP	Touch up paint for repainting scratches or chips.

\*Custom colors are also available.

# Carrier Packaged Terminal Air Conditioner Warranty

**FULL ONE-YEAR WARRANTY** — During the first year after purchase, CARRIER will, through its authorized independent servicing dealers or service stations\*, and free of charge to the user or subsequent users, repair or replace any parts which are defective in material or workmanship. The replacement part can be a new or remanufactured part as provided at CARRIER'S sole option.

**FULL EXTENDED FOUR-YEAR WARRANTY ON SEALED REFRIGERATION SYSTEM ONLY** — During the second through fifth years after date of original purchase, CARRIER will, through its authorized servicing dealers and service stations\* and free of charge to the end user or subsequent users, repair or replace the compressor, condenser, evaporator or connecting tubing if defective in material or workmanship. This includes system refrigeration charge. The replacement part can be new or a remanufactured part as provided at CARRIER'S sole option.

**LIMITED EXTENDED FOUR-YEAR WARRANTY ON NON-SEALED REFRIGERATION SYSTEM ONLY** — During the second through fifth years after date of original purchase, Carrier will, through its authorized servicing dealers and service stations and free of charge to the end user or subsequent users, repair or replace any non-sealed system part (motor, solenoid, thermostat, relay, switch, capacitor, overload, drain valve, bulb heater, fan, stator) if defective in material or workmanship. The replacement part can be new or a remanufactured part at CARRIER'S sole option. THIS LIMITED WARRANTY DOES NOT INCLUDE LABOR, user is responsible for labor, including cost of diagnosis of problem, removal and transportation of the air conditioner to and from the service center, and reinstallation charges necessary to accomplish repair.

**LIMITATION OF WARRANTIES** — ALL IMPLIED WARRANTIES (INCLUDING IMPLIED WARRANTIES OF MERCHANTABILITY) ARE HEREBY LIMITED IN DURATION TO THE PERIOD FOR WHICH EACH LIMITED WARRANTY IS GIVEN AND APPLIES. SOME STATES DO NOT ALLOW LIMITATIONS ON HOW LONG AN IMPLIED WARRANTY LASTS, SO THE ABOVE LIMITATION MAY NOT APPLY TO YOU. THE EXPRESSED WARRANTIES MADE IN THIS WARRANTY ARE EXCLUSIVE AND MAY NOT BE ALTERED, ENLARGED, OR CHANGED BY ANY DISTRIBUTOR, DEALER, OR OTHER PERSON WHATSOEVER.

ALL WORK UNDER THE TERMS OF THIS WARRANTY SHALL BE PERFORMED DURING NORMAL WORKING HOURS. ALL REPLACEMENT PARTS, WHETHER NEW OR REMANUFACTURED, ASSUME AS THEIR WARRANTY PERIOD ONLY THE REMAINING TIME PERIOD OF THIS WARRANTY.

## CARRIER WILL NOT BE RESPONSIBLE FOR:

- CLEANING REQUIRED PRIOR TO WARRANTY REPAIR.**  
Standard maintenance, cleaning or damage resulting from failure to perform normal maintenance as outlined in the owner's manual.
- Instruction on methods of control and use of air conditioning unit after initial installation.
- Damage or repairs needed as a consequence of faulty installation or application. This is the responsibility of the installer.
- Failure to start due to voltage conditions, blown fuses, open circuit breakers or any other damages due to the inadequacy or interruption of electrical services.
- Damage or repairs needed as a consequence of any misapplication, abuse, unauthorized alteration, improper servicing or operation.
- Damage as a result of floods, winds, fires, lightning, accidents, corrosive environment, or other conditions beyond the control of CARRIER.
- EXCEPTION TO CORROSIVE ENVIRONMENT IN ABOVE PARAGRAPH** — Packaged terminal units (52 Series) built with corrosion protection are exempt from the exclusion — "Corrosive Environment." The unit model number is identified on the nameplate with a CP suffix.
- Reimbursement for replacement parts or repair services which are not supplied or designated by CARRIER and which are specifically covered under this warranty.
- CARRIER products installed outside the continental U.S.A., Alaska, Hawaii and Canada.
- Shipping damage or damage as a result of transporting the unit. This is the responsibility of the selling dealer or the authorized Room Air Conditioner service station.
- ANY SPECIAL, INDIRECT OR CONSEQUENTIAL PROPERTY OR COMMERCIAL DAMAGE OF ANY NATURE WHATSOEVER. Some states do not allow the exclusion or limitation of incidental or consequential damages, so the above limitation or exclusion may not apply to you.
- Warranty coverage of accessory items (wall thermostats, wall sleeves, etc.).

NOTE: Service and Maintenance items excluded in this warranty may be covered by a separate service agreement through the seller at time of purchase.

\*Authorized independent dealers or service stations are registered with Carrier Air Conditioning through its distributor organization.

**This warranty gives you specific legal rights, and you may also have other rights which vary from state to state.**

Catalog No. 530-122 (Rev. 3/02)



# Carrier Corporation

## IF YOUR AIR CONDITIONER DOES NOT WORK, FOLLOW THESE STEPS IN ORDER:

1. CHECK THE THINGS YOU CAN DO YOURSELF. These include being sure the air conditioner is plugged in firmly in an appropriate receptacle, checking the fuse or circuit breaker and ensuring its re-placement or resetting, if necessary, and rereading the instruction book to ensure that all controls are set properly. By doing this you can save money. Many unnecessary service calls result in the serviceman doing what the owner can do for him or herself.
2. CONTACT YOUR DEALER OR THE CARRIER AUTHORIZED SERVICE CENTER HE RECOMMENDS. They have been set up to handle the great majority of all possible service problems. The quickest, surest, and best way to get your air conditioner back in service is to use this step before proceeding further.
3. CONTACT THE CARRIER DISTRIBUTOR SERVING YOUR AREA. Your dealer can give you his name or you can consult your yellow pages.
4. CONTACT CARRIER IF A SATISFACTORY SOLUTION IS NOT REACHED IN STEPS 2 AND 3.  
Carrier Air Conditioning  
Consumer Relations Department  
Carrier Parkway, P.O. Box 4808  
Syracuse, New York 13221  
Telephone: 1-800-894-6449