

SINK SPECIFICATIONS

STEELART

BLANCO PRECISION™ MICROEDGE™ 1-3/4 BOWL With Ledge (1 Hole)

Model 516195

BLANCO

FEATURED MODEL

516195 10" bowl depths

ADDITIONAL MODELS

516198 1-3/4 Bowl with Ledge (3 Hole)

516202 1-3/4 Bowl

FEATURES

- 18 gauge, 304 series stainless steel
- 18/10 chrome/nickel content
- Satin polished finish
- Versatile design with Inset (Similar to Drop-in) or Flushmount installation capabilities
- Polished "MicroEdge" rim with 1/4" corner radius
- Stylish drain grooves for improved functionality
- New design allows for easy installation in standard 25" countertop

CODE/STANDARDS COMPLIANCE

ASME 112.19.3-00

IAPMO/UPC listed

OPTIONAL ACCESSORIES

- Sink Grids: 223-190 (Lg), 223-189 (Sm)
 Colander: 224387 (Available May 2009)
 Glass Cutting Board: 224390 (Available May 2009)

WARRANTY

Blanco America's BLANCO PRECISION MICROEDGE sinks feature a LIMITED LIFETIME WARRANTY to be free of all manufacturing defects under normal use. See our complete warranty for details.

While Blanco America endeavors to provide accurate information, all dimensions are nominal, cannot be guaranteed, and are subject to change or cancellation. Blanco America assumes no responsibility for use of superseded or voided specifications.

PRODUCT SPECIFICATION

Inset or Flushmount sink to be 33-1/2" in length and 20-1/2" in front-to-back depth. Each sink is handcrafted from a single panel of 18 gauge, 304 series stainless steel, with 18/10 chrome/nickel content and satin polished finish. Sink to feature polished "MicroEdge" 1/16" rim with 1/4" corner radius edge and rear drain placement. Sink to be Blanco Model 516195, with both left and right bowl equal depths of 10".

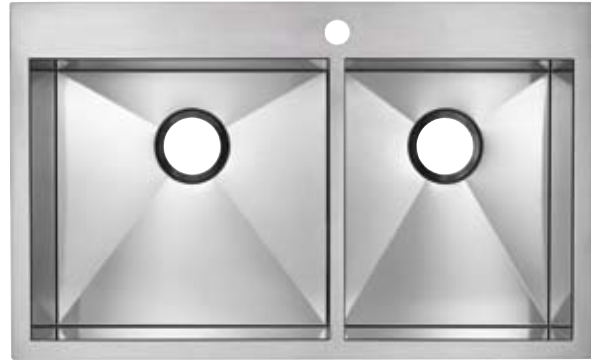

MODEL 516195

NOMINAL DIMENSIONS

MODEL	OVERALL	BOWL DEPTH		DRAIN DIAMETER
		LEFT	RIGHT	
516195	33-1/2 x 20-1/2	10	10	3-1/2

DXF cutout templates available on our web site.

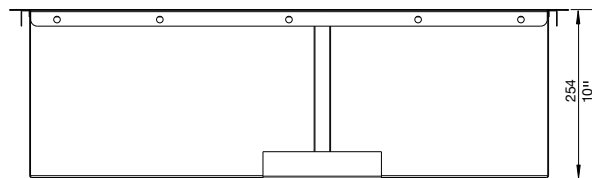
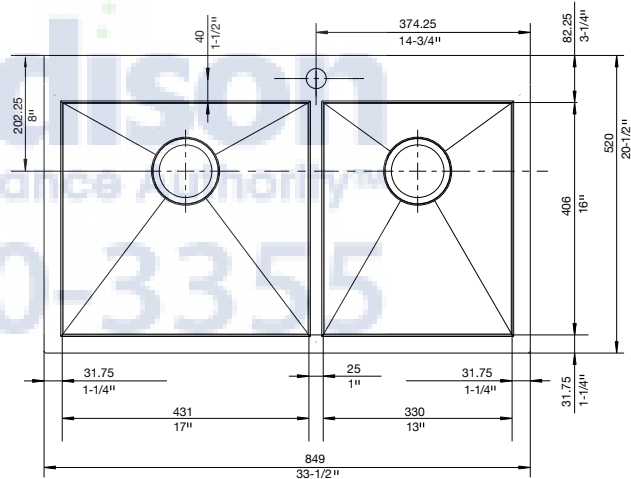

JOB INFORMATION

Job Name: _____

Contact: _____

Date Specified: _____

Specifier: _____

Contractor: _____

BLANCO AMERICA
800.451.5782
www.blancoamerica.com

© 2008 BLANCO AMERICA

11/08

SPEC-003