



Coyote Outdoor Living was conceived to bring to market a suite of products that allows consumers to create the outdoor kitchen of their dreams.

The cornerstone of the lineup is the Coyote grill. In all of the available barbecue models, the Coyote grill marries solid construction with strong aesthetics and remarkable performance. Designed to endure, the Coyote grill will be the heart of the outdoor living space. The ease of use coupled with great cooking performance makes the Coyote grill a must have for your outdoor kitchen.

To complement the grill, Coyote Outdoor Living offers a branded living space that will aesthetically and functionally enhance all outdoor cooking areas. The current Coyote outdoor offering includes a broad range of storage solutions, secondary cooking options, refrigeration, and more.

Whether you are creating an intimate outdoor cooking oasis or an extravagant outdoor kitchen design, Coyote has the product to make your space the envy of the neighborhood.



TABLE OF CONTENTS

	Page
Features and Benefits	4
C-Series Grills	6
28" C-Series Grills and Accessories	7
34" C-Series Grills and Accessories	8
36" C-Series Grills and Accessories	9
S-Series Grills	10
36" S-Series Grills and Accessories	11
42" S-Series Grills and Accessories	12
Hybrid, Charcoal and Smoker Grills	13
50" Centaur Gas Grill and Accessories	14
36" Charcoal Grill and Accessories	15
Asado Smoker	16
Complementary Products	17
Side Burners / Power Burner	18
Access Doors	19
Warming Drawer / Combination Storage Units	20
Drawers / Storage	21
Refrigeration and Drop-in Cooler	22
Refreshment Center / Griddle	23
Dimensions and Specifications	24
Warranty and Service Information	25
Pinnacle Express, Inc. Terms and Conditions	26

STOCK ITEMS ARE LISTED IN RED

FEATURES AND BENEFITS

Premium Fit and Finish:

- Premium 304 Stainless Steel Construction
- Double-Walled Stainless Steel Hood
- Corrosion and Color-Fade Resistant
- Ergonomic Handle
- Nickel Alloy Knobs
- Full attention to all finish details

One Year Limited Parts and Labor Warranty Included on All Grills Not Sold on the Internet

Two Year Limited Parts and Labor Warranty Available for an Additional Fee for All Grills

Limited Lifetime Warranty on the Housing and the Burner

Large Cooking Area on All Grill Models

Fuel Efficient Cast Stainless Steel Burners and Premium Grates

Warming Rack and Performance Enhancing Heat Control Grids™ – Included on All Models

Interior Lights, Temperature Gauge, Electronic Ignition, and Removable Drip Tray - Included on All Models

Grill Carts – Commercial Grade – Self Closing Cabinets/Drawers – Prebuilt



FEATURES AND BENEFITS

Full Line of Competitively Priced Grill Accessories including:

- Side Burners
- Power Burners with Optional Teppanyaki/Wok
- Warming Drawers
- Access Doors
- Storage Drawers
- Combination Storage Units
- Drop-in Coolers
- Refreshment Center
- Outdoor Refrigerators
- Insulated Jackets
- Grill and Accessory Covers



FEATURE COMPARISON

Features	28" C-Series	34" C-Series	36" C-Series	36" S-Series	42" S-Series
Cooking Area (In Square Inches)	640	780	875	875	1,275
BTUs (Maximum)	40,000	60,000	80,000	90,000	110,000
Cast SS Infinity Burners™	2	0	0	3	4
Cast SS Coyote iBurners™	0	3	4	0	0
Infrared Rear Burners	No	No	No	Yes	Yes
RapidSear™ Burner	No	No	No	Yes	Yes
Interior Hood Lights	Yes	Yes	Yes	Yes	Yes
Backlit Knobs	No	No	No	Yes	Yes
Rotisserie Kit Included	No	No	No	Yes	Yes
Smoker Box Included	No	No	No	Yes	Yes
Individual Electric Ignition	Yes	Yes	Yes	Yes	Yes

C-SERIES GRILLS

The Coyote C-Series grills are made to meet the needs of the most demanding grill masters. The C-Series features premium stainless steel construction with hand-welded stainless steel burners, grates and components. All C-Series grills feature double-walled canopies and a continuously welded grill box with seamless edging. All C-Series grills also have a stainless warming rack and Coyote's Heat Control Grids™.

Standard Features:

- Premium 304 Stainless Steel Construction
- One Year Limited Parts and Labor Warranty Included on All Grills Not Sold on the Internet
- Continuous Weld on Grill Box with Seamless Polished Edging
- Cast Stainless Steel 20,000 BTU *Infinity Burners™* (28" Model Only)
- Double Walled Stainless Steel Hood
- Interior Hood Lights
- Nickel Alloy Knobs
- Heat Control Grids™ for Even Distribution
- Temperature Gauge and Removable Drip Tray
- Cart Bodies Arrive Fully Assembled

28" C-Series Grill

- Two High Performance Coyote *Infinity Burners™*
- 640 Sq. In. Cooking Area
- Interior Hood Lights
- Up To 40,000 BTUs
- Regulator is Included
- Individual Electric Ignition



34" C-Series Grill

- Three High Performance Coyote iBurners™
- 780 sq. in. Cooking Area
- Interior Hood Lights
- Up to 60,000 BTUs
- Regulator is Included
- Individual Electric Ignition

36" C-Series Grill

- Four high performance Coyote iBurners™
- 875 sq. in. of Cooking Area
- Interior Hood Lights
- Up to 80,000 BTUs
- Regulator is Included
- Individual Electric Ignition



STOCK ITEMS ARE LISTED IN RED

28" C-SERIES GRILLS



Freestanding CY-C1C28 -
*Arrives in One Box
Pre-Assembled!*

28" C-Series Grill Features

- Two High Performance Coyote *Infinity Burners™*
- 640 Sq. In. Cooking Area
- Interior Hood Lights
- Up To 40,000 BTUs
- Cutout dimensions: 11" X 25" X 20.5"
- Overall dimensions: 22.5" X 28" X 23.75
- Regulator is Included
- Individual Electric Ignition

28" C-Series Grills

MODEL	DESCRIPTION	UMRP	BUILDER	MSRP (Retail)
CY-C1C28LP	Coyote C-Series 28" Grill - 2 SS Infinity Burners, LP	\$ 999	\$1,029	\$1,099
CY-C1C28NG	Coyote C-Series 28" Grill - 2 SS Infinity Burners, NG	\$ 999	\$1,029	\$1,099
CY-C1C28LP-FS	Coyote C-Series 28" Grill with Cart - 2 SS Burners, LP	\$1,199	\$1,235	\$ 1,319
CY-C1C28NG-FS	Coyote C-Series 28" Grill with Cart - 2 SS Burners, NG	\$1,199	\$1,235	\$ 1,319

28" C-Series Accessories

MODEL	DESCRIPTION	UMRP	BUILDER	MSRP (Retail)
CY-CJAKTCC2	Insulated Jacket for C1C28	\$ 479	\$ 493	\$ 529
CY-CCVR2-BI	C1C28 Grill Cover (Grill Head Only)	\$ 59	\$ 61	\$ 69
CY-CCVR2-CT	C1C28 Grill Cover (Grill plus Cart)	\$ 99	\$ 1092	\$ 109
CY-CROTC2	Rotisserie Kit for C1C28	\$ 199	\$ 205	\$ 219
CY-CSBX	Smoker Box	\$ 39	\$ 40	\$ 45
CY-CGRDL	Heavy Duty Drop-In Griddle, 2015 and Earlier Models - See Page 23 for more details	\$ 249	\$ 256	\$ 279
CY-C1GRDL	Heavy Duty Drop-In Griddle, 2016 Models - See Page 23 for more details	\$ 249	\$ 256	\$ 279
CY-CCX2LP2NG	LP to NG Conversion Kit (Models Manufactured 2015 and Earlier)	\$ 89	\$ 92	\$ 99
CY-CCX2NG2LP	NG to LP Conversion Kit (Models Manufactured 2015 and Earlier)	\$ 89	\$ 92	\$ 99
CY-C128LP2NG	C1C28 Conversion Kit LP to NG	\$ 89	\$ 92	\$ 99
CY-C128NG2LP	C1C28 Conversion Kit NG to LP	\$ 89	\$ 92	\$ 99
CY-CLPREG	LP Regulator	\$ 39	\$ 40	\$ 49
CY-CNGREG	Natural Gas Regulator	\$ 49	\$ 50	\$ 59
CY-CWG28	Wind Guard for 28" Grill	\$ 35	\$ 36	\$ 39
CY-CSIGRATE15	Signature Grates 3 pk - 28" and 42" Grills	\$ 299	\$ 308	\$ 329
CY-CCHTRAY15	Charcoal Trays 1 pc - 28" and 42" Grills	\$ 99	\$ 102	\$ 109
CY-CINLNREG	1/2" In-line Regulator (Required for use with underground LP tank)	\$ 39	\$ 40	\$ 49
CY-2YRWARR	2 Year Parts and Labor Warranty	\$ 89	\$ 92	\$ 99

34" C-SERIES GRILLS



CY-C1C34 with Optional Cart
(Cart Body Arrives Fully Assembled)

34" C-Series Grill Features

- Three High Performance Coyote iBurners™
- 780 sq. in. Cooking Area
- Interior Hood Lights
- Up to 60,000 BTUs
- Cutout dimensions: 11" X 31" X 20.5"
- Overall dimensions: 22.5" X 34" X 23.75"
- Regulator is Included
- Individual Electric Ignition

34" C-Series Grills

MODEL	DESCRIPTION	UMRP	BUILDER	MSRP (Retail)
CY-C1C34LP	Coyote C-Series 34" Grill - 3 SS iBurners, LP	\$1,299	\$1,338	\$1,429
CY-C1C34NG	Coyote C-Series 34" Grill - 3 SS iBurners, NG	\$1,299	\$1,338	\$1,429
CY-C1C34CT	Cart for C1C34 34" Grill	\$ 549	\$ 565	\$ 599

34" C-Series Accessories

MODEL	DESCRIPTION	UMRP	BUILDER	MSRP (Retail)
CY-CJAKTCC3	Insulated Jacket for C1C34	\$ 529	\$ 545	\$ 589
CY-CCVR3-BI	C1C34 Grill Cover (Grill Head Only)	\$ 65	\$ 67	\$ 79
CY-CCVR3-CT	C1C34 Grill Cover (Grill plus Cart)	\$ 119	\$ 123	\$ 129
CY-CROTC3	Rotisserie Kit for C1C34	\$ 199	\$ 205	\$ 219
CY-CSBX	Smoker Box	\$ 39	\$ 40	\$ 45
CY-CGRDL	Heavy Duty Drop-In Griddle, 2015 and Earlier Models - See Page 23 for more details	\$ 249	\$ 256	\$ 279
CY-C1GRDL	Heavy Duty Drop-In Griddle, 2016 Models - See Page 23 for more details	\$ 249	\$ 256	\$ 279
CY-CXLP2NG	LP to NG Conversion Kit (Models Manufactured 2015 and Earlier)	\$ 89	\$ 92	\$ 99
CY-CXNG2LP	NG to LP Conversion Kit (Models Manufactured 2015 and Earlier)	\$ 89	\$ 92	\$ 99
CY-C1CLP2NG	Conversion Kit LP to NG	\$ 89	\$ 92	\$ 99
CY-C1CNG2LP	Conversion Kit NG to LP	\$ 89	\$ 92	\$ 99
CY-CLPREG	LP Regulator	\$ 39	\$ 40	\$ 49
CY-CNGREG	Natural Gas Regulator	\$ 49	\$ 50	\$ 59
CY-CWG34	Wind Guard for 34" Grill	\$ 37	\$ 38	\$ 42
CY-CSIGRATE12	Signature Grates 3 pk - 34" and 36" Grills	\$ 299	\$ 308	\$ 329
CY-CCHTRAY12	Charcoal Trays 1 pk - 34" and 36" Grills	\$ 99	\$ 102	\$ 109
CY-CINLNREG	1/2" In-line Regulator (Required for use with underground LP tank)	\$ 39	\$ 40	\$ 49
CY-2YRWARR	2 Year Parts and Labor Warranty	\$ 89	\$ 92	\$ 99

36" C-SERIES GRILLS



CY-C1C36 with Optional Cart
(Cart Body Arrives Fully Assembled)

36" C-Series Grill Features

- 4 high performance Coyote iBurners™
- 875 sq. in. of Cooking Area
- Up to 80,000 BTU
- Interior hood lights
- Cutout dimensions: 11" x 32.5" x 20.5"
- Overall dimensions: 22.5" x 35.5" x 23.75"
- Regulator is Included
- Individual Electric Ignition

36" C-Series Grills

MODEL	DESCRIPTION	UMRP	BUILDER	MSRP (Retail)
CY-C1C36LP	Coyote C-Series 36" Grill - 4 SS iBurners, LP	\$1,599	\$1,647	\$1,759
CY-C1C36NG	Coyote C-Series 36" Grill - 4 SS iBurners, NG	\$1,599	\$1,647	\$1,759
CY-C1S36CT	Cart for C1C36	\$ 599	\$ 617	\$ 659

36" C-Series Accessories

MODEL	DESCRIPTION	UMRP	BUILDER	MSRP (Retail)
CY-CJAKTCS36	Insulated Jacket for C1C36	\$ 539	\$ 555	\$ 599
CY-CCVR36-BI	C1C36 Grill Cover (Grill Head Only)	\$ 65	\$ 67	\$ 79
CY-CCVR36-CT	C1C36 Grill Cover (Grill plus Cart)	\$ 119	\$ 123	\$ 129
CY-CROTC36	Rotisserie Kit for C1C36	\$ 199	\$ 205	\$ 219
CY-CSBX	Smoker Box	\$ 39	\$ 40	\$ 45
CY-CGRDL	Heavy Duty Drop-In Griddle, 2015 and Earlier Models - See Page 23 for more details	\$ 249	\$ 256	\$ 279
CY-C1GRDL	Heavy Duty Drop-In Griddle, 2016 Models - See Page 23 for more details	\$ 249	\$ 256	\$ 279
CY-CXLP2NG	LP to NG Conversion Kit (Models Manufactured 2015 and Earlier)	\$ 89	\$ 92	\$ 99
CY-CXNG2LP	NG to LP Conversion Kit (Models Manufactured 2015 and Earlier)	\$ 89	\$ 92	\$ 99
CY-C1CLP2NG	Conversion Kit LP to NG	\$ 89	\$ 92	\$ 99
CY-C1CNG2LP	Conversion Kit NG to LP	\$ 89	\$ 92	\$ 99
CY-CLPREG	LP Regulator	\$ 39	\$ 40	\$ 49
CY-CNGREG	Natural Gas Regulator	\$ 49	\$ 50	\$ 59
CY-CWG36	Wind Guard for 36" Grill	\$ 39	\$ 40	\$ 44
CY-CSIGRATE12	Signature Grates 3 pk - 34" and 36" Grills	\$ 299	\$ 308	\$ 329
CY-CCHTRAY12	Charcoal Trays 1 pk - 34" and 36" Grills	\$ 99	\$ 102	\$ 109
CY-CINLNREG	1/2" In-line Regulator (Required for use with underground LP tank)	\$ 39	\$ 40	\$ 49
CY-2YRWARR	2 Year Parts and Labor Warranty	\$ 89	\$ 92	\$ 99

S-SERIES GRILLS

The Coyote S-Series grills combine ultra-premium power, function and performance with design and durability. The S-Series features premium stainless steel construction with hand-welded stainless steel Coyote Infinity Burners™, grates and component parts. All S-Series grills feature double-walled canopies and a continuously welded grill box with seamless edging. All S-series grills also have a stainless warming rack and Coyote's Heat Control Grids™ and include LED Backlit knobs, interior grill lighting and smoker boxes as standard features.

Standard Features:

- Premium 304 Stainless Steel Construction
- One Year Limited Parts and Labor Warranty Included on All Grills Not Sold on the Internet
- Continuous Weld on Grill Box with Seamless Polished Edging
- Cast Stainless Steel 20,000 BTU *Infinity Burners*™
- Double Walled Stainless Steel Hood
- Interior Hood Lights
- Nickel Alloy Knobs
- Heat Control Grids™ for Even Distribution
- Temperature Gauge and Removable Drip Tray
- Individual Electric Ignition

36" S-Series Grill

- 3 high performance Coyote *Infinity Burners*™; 1 infrared rear burner; 1 Coyote RapidSear™ burner
- 875 sq. in. Cooking Area
- Backlit LED knobs
- Up to 95,000 BTUs
- Cutout dimensions: 11" X 32.5" X 20.5"
- Overall dimensions: 22.5" X 35.5" X 23.75"
- Regulator is Included

42" S-Series Grill

- 4 high performance Coyote *Infinity Burners*™; 1 infrared rear burner; 1 Coyote RapidSear™ burner
- Backlit LED knobs
- 1275 sq. in. Cooking Area
- Up to 115,000 BTUs
- Interior halogen grill lighting
- Cutout dimensions: 11" X 39.5" X 20.5"
- Overall dimensions: 22.5" X 42" X 23.75"
- Regulator is Included



STOCK ITEMS ARE LISTED IN RED

36" S-SERIES GRILLS



36" S-Series Grill Features

- 3 high performance Coyote Infinity Burners™; 1 infrared rear burner; 1 Coyote RapidSear™ burner
- 875 sq. in. Cooking Area
- Up to 90,000 BTUs
- Cutout dimensions: 11" X 32.5" X 20.5"
- Overall dimensions: 22.5" X 35.5" X 23.75"
- Regulator is Included
- Rotisserie Kit and Smoker Box Included
- Individual Electric Ignition

36" S-Series Grills

MODEL	DESCRIPTION	UMRP	BUILDER	MSRP (Retail)
CY-C1SL36LP	Coyote S-Series 36" Grill with LED Backlit Knobs - LP	\$2,199	\$2,265	\$2,419
CY-C1SL36NG	Coyote S-Series 36" Grill with LED Backlit Knobs - NG	\$2,199	\$2,265	\$2,419
CY-C1S36CT	Cart for C1SL36 Grill	\$ 599	\$ 617	\$ 659

36" S-Series Accessories

MODEL	DESCRIPTION	UMRP	BUILDER	MSRP (Retail)
CY-CJAKTCS36	Insulated Jacket for C1SL36	\$ 539	\$ 555	\$ 599
CY-CCVR36-BI	C1SL36 Grill Cover (Grill Head Only)	\$ 65	\$ 67	\$ 79
CY-CCVR36-CT	C1SL36 Grill Cover (Grill plus Cart)	\$ 119	\$ 123	\$ 129
CY-CROT36	Rotisserie Kit for C1SL36	\$ 199	\$ 205	\$ 219
CY-CSBX	Smoker Box	\$ 39	\$ 40	\$ 45
CY-CGRDL	Heavy Duty Drop-In Griddle, 2015 and Earlier Models - See Page 23 for more details	\$ 249	\$ 256	\$ 279
CY-C1GRDL	Heavy Duty Drop-In Griddle, 2016 Models - See Page 23 for more details	\$ 249	\$ 256	\$ 279
CY-CXLP2NG	LP to NG Conversion Kit (Models Manufactured 2015 and Earlier)	\$ 89	\$ 92	\$ 99
CY-CXNG2LP	NG to LP Conversion Kit (Models Manufactured 2015 and Earlier)	\$ 89	\$ 92	\$ 99
CY-C1SLP2NG	Conversion Kit LP to NG	\$ 89	\$ 92	\$ 99
CY-C1SNG2LP	Conversion Kit NG to LP	\$ 89	\$ 92	\$ 99
CY-CLPREG	LP Regulator	\$ 39	\$ 40	\$ 49
CY-CNGREG	Natural Gas Regulator	\$ 49	\$ 50	\$ 59
CY-CWG36	Wind Guard for 36" Grill	\$ 39	\$ 40	\$ 44
CY-CSIGRATE12	Signature Grates 3 pk - 34" and 36" Grills	\$ 299	\$ 308	\$ 329
CY-CCHTRAY12	Charcoal Trays 1 pk - 34" and 36" Grills	\$ 99	\$ 102	\$ 109
CY-CINLNREG	1/2" In-line Regulator (Required for use with underground LP tank)	\$ 39	\$ 40	\$ 49
CY-2YRWARR	2 Year Parts and Labor Warranty	\$ 89	\$ 92	\$ 99

42" S-SERIES GRILLS



CY-C1SL42 with Optional Cart
(Cart Body Arrives Fully Assembled)

42" S-Series Grill Features

- 4 high performance Coyote Infinity Burners™; 1 infrared rear burner; 1 Coyote RapidSear™ burner
- 1275 sq. in. Cooking Area
- Up to 110,000 BTUs
- Cutout dimensions: 11" X 39.5" X 20.5"
- Overall dimensions: 22.5" X 42" X 23.75"
- Regulator is Included
- Rotisserie Kit and Smoker Box Included
- Individual Electric Ignition

42" S-Series Grills

MODEL	DESCRIPTION	UMRP	BUILDER	MSRP (Retail)
CY-C1SL42LP	Coyote S-Series 42" Grill with LED Backlit Knobs - LP	\$2,999	\$3,089	\$3,299
CY-C1SL42NG	Coyote S-Series 42" Grill with LED Backlit Knobs - NG	\$2,999	\$3,089	\$3,299
CY-C1S42CT	Cart for C1SL42 Grill	\$ 799	\$ 823	\$879

42" S-Series Accessories

MODEL	DESCRIPTION	UMRP	BUILDER	MSRP (Retail)
CY-CJAKTCS42	Insulated Jacket for C1SL42	\$ 619	\$ 638	\$ 679
CY-CCVR42-BI	C1SL42 Grill Cover (Grill Head Only)	\$ 69	\$ 71	\$ 79
CY-CCVR42-CT	C1SL42 Grill Cover (Grill plus Cart)	\$ 139	\$ 143	\$ 159
CY-CROT42	Rotisserie Kit for C1SL42	\$ 199	\$ 205	\$ 219
CY-CSBX	Smoker Box	\$ 39	\$ 40	\$ 45
CY-CGRDL	Heavy Duty Drop-In Griddle, 2015 and Earlier Models - See Page 23 for more details	\$ 249	\$ 256	\$ 279
CY-C1GRDL	Heavy Duty Drop-In Griddle, 2016 Models - See Page 23 for more details	\$ 249	\$ 256	\$ 279
CY-CXLP2NG	LP to NG Conversion Kit (Models Manufactured 2015 and Earlier)	\$ 89	\$ 92	\$ 99
CY-CXNG2LP	NG to LP Conversion Kit (Models Manufactured 2015 and Earlier)	\$ 89	\$ 92	\$ 99
CY-C1SLP2NG	Conversion Kit LP to NG	\$ 89	\$ 92	\$ 99
CY-C1SNG2LP	Conversion Kit NG to LP	\$ 89	\$ 92	\$ 99
CY-CLPREG	LP Regulator	\$ 39	\$ 40	\$ 49
CY-CNGREG	Natural Gas Regulator	\$ 49	\$ 50	\$ 59
CY-CWG42	Wind Guard for 42" Grill	\$ 44	\$ 45	\$ 49
CY-CSIGRATE15	Signature Grates 3 pk - 28" and 42" Grills	\$ 299	\$ 308	\$ 329
CY-CCHTRAY15	Charcoal Trays 1 pk - 28" and 42" Grills	\$ 99	\$ 102	\$ 109
CY-CINLNREG	In-line Regulator (Required for use with underground LP tank)	\$ 39	\$ 40	\$ 49
CY-2YRWARR	2 Year Parts and Labor Warranty	\$ 89	\$ 92	\$ 99

HYBRID, CHARCOAL AND SMOKER

Many outdoor cooking enthusiasts appreciate how charcoal grilling and smoking can almost seem poetic...the slow cooking, the importance of precision temperature control, the natural smells; the style is truly a culinary art form. Coyote Outdoor Living's charcoal grills and smokers bring our promise of passion, design and value to this art form.

Hybrid Standard Features:

- Premium 304 Stainless Steel Construction
- One Year Limited Parts and Labor Warranty Included on All Grills
- Continuous Weld on Grill Box with Seamless Polished Edging
- Double Walled Stainless Steel Hood
- Interior Hood Lights
- Nickel Alloy Knobs
- Heat Control Grids™ for Even Distribution
- Temperature Gauge and Removable Drip Tray
- Individual Electric Ignition on Hybrid Grill

Charcoal Standard Features:

- Premium 304 Stainless Steel Construction
- One Year Limited Parts and Labor Warranty Included on All Grills
- Continuous Weld on Grill Box with Seamless Polished Edging
- Double Walled Stainless Steel Hood
- Interior Hood Lights
- Nickel Alloy Knobs
- Heat Control Grids™ for Even Distribution
- Temperature Gauge and Removable Drip Tray
- Adjustable fuel tray
- Adjustable dampers for controlling air flow

Asado Smoker Features:

- Coyote Signature Smoking Grate™
- Heat-resistant ceramic construction
- 254 sq. in. of cooking area
- Adjustable venting to maintain precise cooking temperatures
- Smoke, sear, grill option
- Optional cart with side shelves



50" COYOTE CENTAUR GAS GRILL AND ACCESSORIES



**CY-C1HY50 with
Optional Cart**
(Cart Body arrives
fully assembled)

Hybrid Grill Features

- 2 high performance Coyote iBurners™
- Over 600 sq. in. of grilling surface on each side
- Up to 40,000 BTUs on the gas side
- Adjustable fuel tray for cooking flexibility
- For use with charcoal or wood chips
- Regulator is Included
- Adjustable dampers for controlling air flow

Hybrid Grills

MODEL	DESCRIPTION	UMRP	BUILDER	MSRP (Retail)
CY-C1HY50LP	Coyote Centaur Hybrid Grill - LP	\$2,999	\$3,089	\$3,299
CY-C1HY50NG	Coyote Centaur Hybrid Grill - NG	\$2,999	\$3,089	\$3,299
CY-C1HY50CT	Cart for C1HY50 Hybrid Grill	\$ 849	\$ 874	\$ 939

Hybrid Grill Accessories

MODEL	DESCRIPTION	UMRP	BUILDER	MSRP (Retail)
CY-CCVR50-BI	C1HY50 Grill Cover (Grill Head Only)	\$ 79	\$ 81	\$ 89
CY-CCRV50-CT	C1HY50 Grill Cover (Grill Plus Cart)	\$ 149	\$ 153	\$ 169
CY-CSBX	Smoker Box	\$ 39	\$ 40	\$ 45
CY-CGRDL	Heavy Duty Drop-In Griddle, 2015 and Earlier Models - See Page 23 for more details	\$ 249	\$ 256	\$ 279
CY-C1GRDL	Heavy Duty Drop-In Griddle, 2016 Models - See Page 23 for more details	\$ 249	\$ 256	\$ 279
CY-CXLP2NG	LP to NG Conversion Kit (Models Manufactured 2015 and Earlier)	\$ 89	\$ 92	\$ 99
CY-CXNG2LP	NG to LP Conversion Kit (Models Manufactured 2015 and Earlier)	\$ 89	\$ 92	\$ 99
CY-C1SLP2NG	Conversion Kit LP to NG	\$ 89	\$ 92	\$ 99
CY-C1SNG2LP	Conversion Kit NG to LP	\$ 89	\$ 92	\$ 99
CY-CLPREG	LP Regulator	\$ 39	\$ 40	\$ 49
CY-CNGREG	Natural Gas Regulator	\$ 49	\$ 50	\$ 59
CY-CINLNREG	In-Line Regulator (Required for use with underground LP tank)	\$ 39	\$ 40	\$ 49
CY-2YRWARR	2 Year Parts and Labor Warranty	\$ 89	\$ 92	\$ 99

36 CHARCOAL GRILL AND ACCESSORIES



Charcoal Grill Features

- Adjustable fuel tray
- Fuel tray rests on drawer that pulls out for easy access to charcoal
- Over 875 sq. in. of grilling surface
- For use with charcoal or wood chips
- Adjustable dampers for controlling air flow

Charcoal Grills

MODEL	DESCRIPTION	UMRP	BUILDER	MSRP (Retail)
CY-C1CH36	36" Charcoal Grill Built-in	\$1,599	\$ 1,647	\$1,759
CY-C1CH36CT	Cart for 36" Charcoal Grill	\$ 599	\$ 617	\$ 659

Charcoal Grill Accessories

MODEL	DESCRIPTION	UMRP	BUILDER	MSRP (Retail)
CY-CCVR36-BI	C1CH36 Grill Cover (Grill Head Only)	\$ 59	\$ 67	\$ 65
CY-CCVR36-CT	C1CH36 Grill Cover (Grill Plus Cart)	\$ 105	\$ 123	\$ 119
CY-CROT36	Rotisserie Kit for C1CH36	\$ 175	\$ 205	\$ 199
CY-CSBX	Smoker Box	\$ 39	\$ 40	\$ 45
CY-CGRDL	Heavy Duty Drop-In Griddle, 2015 and Earlier Models - See Page 23 for more details	\$ 249	\$ 256	\$ 279
CY-C1GRDL	Heavy Duty Drop-In Griddle, 2016 Models - See Page 23 for more details	\$ 249	\$ 256	\$ 279
CY-2YRWARR	2 Year Parts and Labor Warranty	\$ 89	\$ 92	\$ 99

ASADO SMOKER AND ACCESSORIES



CY-C1CHCS - FS Includes Side Shelves and Cart
(Not fully assembled)

Asado Smoker Features

- Coyote Signature Smoking Grate
- Heat-resistant Ceramic Construction
- 254 sq. in. of Cooking Surface
- Smoke, Sear, Grill Option
- Adjustable Venting to Maintain Precise Cooking Temperatures
- Optional Cart with Side Shelves Available

Asado Smoker

MODEL	DESCRIPTION	UMRP	BUILDER	MSRP (Retail)
CY-C1CHCS	Asado Smoker, Built-In	\$ 999	\$1,029	\$1,099
CY-C1CHCS-FS	Asado Smoker with Stand and Side Shelves	\$1,199	\$1,235	\$ 1,319
CY-C1CHCS-CT	Cart for Asado Smoker	\$ 199	\$ 205	\$ 219

COMPLEMENTARY PRODUCTS

Coyote offers a full range of complementary products that will last a lifetime, all in an elegant, timeless style.



CY-CDIC - Drop In Cooler



CY-CBIR Outdoor Refrigerator



CY-C1PB Power Burner

*Shown with optional CY-CTEP teppanyaki accessory

SIDE BURNERS AND POWER BURNER



CY-C1SB - Single Side Burner

- (1) 15k brass burner
- 304 grade S/S lid included
- Cutout: 10.5" X 10.5" X 14"
- Overall: 13.25" X 11.5" X 17"
- Regulator is Included
- Individual Electric Ignition



CY-C1DB - Dual Side Burner

- (2) 15k brass burners
- 304 grade S/S lid included
- Cutout: 10.5" X 12" X 20.5"
- Overall: 13.25" X 13.25" X 23"
- Regulator is Included
- Individual Electric Ignition

SIDE BURNERS AND ACCESSORIES

MODEL	DESCRIPTION	UMRP	BUILDER	MSRP (Retail)
CY-C1SBLP	Single Side Burner, LP	\$ 399	\$ 411	\$ 439
CY-C1SBNG	Single Side Burner, NG	\$ 399	\$ 411	\$ 439
CY-C1CSBLP	Single Side Burner for Carts, LP	\$ 599	\$ 617	\$ 659
CY-C1CSBNG	Single Side Burner for Carts, NG	\$ 599	\$ 617	\$ 659
CY-CCVRSB-BI	Cover for C1SB	\$ 39	\$ 40	\$ 49
CY-C1DBLP	Dual Side Burner, LP	\$ 699	\$ 720	\$ 769
CY-C1DBNG	Dual Side Burner, NG	\$ 699	\$ 720	\$ 769
CY-CCVRDB-BI	Cover for C1DB	\$ 39	\$ 40	\$ 49
CY-CINLNREG	In-Line Regulator (Required for use with underground LP tank)	\$ 39	\$ 40	\$ 49
CY-2YRWARR	2 Year Parts and Labor Warranty	\$ 89	\$ 92	\$ 99

**POWER BURNER
Model No. CY-C1PB**

- Dual-valve burner with up to 60k BTU output
- 304 Grade S/S lid included
- Simmer performance at 1k BTU
- Teppanyaki/Wok optional
- Cutout - 11.5" x 21" x 22.5"
- Overall - 12.75" x 24" x 26"
- Regulator is Included
- Individual Electric Ignition



POWER BURNERS AND ACCESSORIES

MODEL	DESCRIPTION	UMRP	BUILDER	MSRP (Retail)
CY-C1PBLP	Power Burner, LP	\$ 1,099	\$ 1,132	\$ 1,199
CY-C1PBNG	Power Burner, NG	\$ 1,099	\$ 1,132	\$ 1,199
CY-C1TEP	Teppanyaki Accessory	\$ 399	\$ 411	\$ 439
CY-C1WOK	Wok for Power Burner	\$ 99	\$ 102	\$ 109
CY-CINLNREG	In-Line Regulator (Required for use with underground LP tank)	\$ 39	\$ 40	\$ 49
CY-2YRWARR	2 Year Parts and Labor Warranty	\$ 89	\$ 92	\$ 99

ACCESS DOORS



CY-CSA2014

- 20"H x 14"W hinge side access door

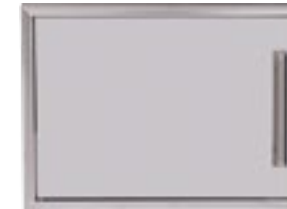

CY-CSA1420

- 14"H x 20"W hinge side access door



CY-CSA2417

- 24"H x 17"W hinge side access door



CY-CSA1724

- 17"H x 24"W hinge side access door



CY-CDA2426

- Integrated door handles
- Magnetic latches for easy closing
- 24"H x 26"W



CY-CDA2431

- Paper towel holder inside door
- Integrated door handles
- Magnetic latches for easy closing
- 24"H x 31"W



CY-CDA2439

- Paper towel holder inside door
- Integrated door handles
- Magnetic latches for easy closing
- 24"H x 39"W

ACCESS DOORS

MODEL	DESCRIPTION	UMRP	BUILDER	MSRP (Retail)
CY-CSA2014	Single Access Door 20" x 14"	\$189	\$195	\$209
CY-CSA1420	Single Access Door 14" x 20"	\$189	\$195	\$209
CY-CSA2417	Single Access Door 24" x 17"	\$229	\$236	\$249
CY-CSA1724	Single Access Door 17" x 24"	\$229	\$236	\$249
CY-CDA2426	26" Double Access Door	\$239	\$246	\$259
CY-CDA2431	31" Double Access Door	\$279	\$287	\$309
CY-CDA2439	39" Double Access Door	\$299	\$308	\$329

DRAWERS / STORAGE



CY-CWD - Warming Drawer

- Premium 304 grade stainless steel construction
- Outdoor-rated ETL certified
- Internal electric heating element
- 30" overall width

WARMING DRAWER

MODEL	DESCRIPTION	UMRP	BUILDER	MSRP (Retail)
CY-CWD	Warming Drawer	\$1,199	\$1,235	\$1,319
CY-2YRWARR	2 Year Parts and Labor Warranty	\$ 89	\$ 92	\$ 99



COMBO DRAWERS
Model No. CY-CCD-POD

- Pull out Drawer plus Double Access Doors



COMBO DRAWERS
Model No. CY-CCD-2DC

- Two Drawer Cabinet plus Double Access Doors



COMBO DRAWERS
Model No. CY-CCD-WD

- Warming Drawer, Storage Drawer plus Single Access Door



COMBO DRAWERS
Model No. CY-CCD-2DC31

- Two Drawer Cabinet plus Single Access Doors



DRY PANTRY 31"
Model No. CY-CDPC31

- 304 stainless steel construction
- Fully enclosed cabinet
- Gasket seal for weather-proofing
- Adjustable shelf
- Removable drawers



PULL OUT TRASH AND RECYCLE
Model No. CY-CTC

- 304 stainless steel construction
- Holds two 13 gallon trash cans
- Comes with trash cans
- Can hold up to 60 lbs

COMBINATION STORAGE SOLUTIONS

MODEL	DESCRIPTION	UMRP	BUILDER	MSRP (Retail)
CY-CCD-POD	Combo Drawer - Pull Out LP Tank and Double Door	\$ 549	\$ 565	\$ 599
CY-CCD-2DC	Combo Drawer - 2 Drawer Cabinet and Double Door	\$ 649	\$ 668	\$ 719
CY-CCD-WD	Combo Drawer - Warming Drawer, Storage Drawer, Single Access Door	\$1,499	\$1,544	\$1,649
CY-CCD-2DC31	Combo Drawer 31" - 2 Drawer Cab and Single Door	\$ 649	\$ 668	\$ 719
CY-CDPC31	Dry Pantry 31" - 2 Drawer Cab and Single Door	\$ 899	\$ 926	\$ 989
CY-CTC	Pull Out Trash and Recycle	\$ 549	\$ 565	\$ 599

DRAWERS / STORAGE



CY-CPTH - Paper Towel Holder

- Convenient and easy to install



CY-CSSD - Single Storage Drawer with Shelf

- Easy open drawer
- Additional shelf space within drawer
- Large storage space



CY-C2DC - Two-Drawer Cabinet

- Easy open drawers
- Large storage space within each drawer



CY-C3DC - Three-Drawer Cabinet

- Extended drawers on rollers facilitate smooth operation
- Rigid welded-construction to ensure strength and longevity
- Professional-style door handles



CY-CPOD - LP Pullout Drawer

- Extendable drawers on rollers
- Interior of drawer includes cut-out to secure tank
- Can be used to hold a garbage can
- Professional-style door handle

DRAWERS / STORAGE

MODEL	DESCRIPTION	UMRP	BUILDER	MSRP (Retail)
CY-CPTH	Paper Towel Holder	\$ 119	\$ 123	\$ 129
CY-CSSD	Single Storage Drawer	\$479	\$493	\$529
CY-C2DC	2 Drawer Cabinet	\$459	\$473	\$509
CY-C3DC	3 Drawer Cabinet	\$499	\$ 514	\$549
CY-CPOD	Pull Out Drawer (Trash or LP Tank Drawer)	\$ 319	\$329	\$349

COMPLEMENTARY PRODUCTS



OUTDOOR REFRIGERATOR
Model No. CY-CBIR
(L or R)

- Outdoor rated, free-standing refrigerator
- Automatic defrost
- Stainless steel exterior, white interior
- Capacity of 4.1 Cubic feet
- Interior light and adjustable thermostat
- Front vented for built-in application
- Left or Right hinge swing



OUTDOOR REFRIGERATOR
Model No. CY-C1BIR24
(L or R)

- Outdoor rated, free-standing with lock
- Automatic defrost
- Stainless steel cabinet construction; graphite interior
- Capacity of 5.5 cubic feet
- Interior light and adjustable digital thermostat
- Front vented for built-in application
- Hidden Left or Right hinge swing

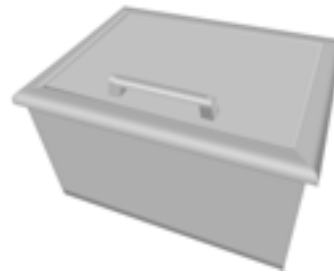

DROP-IN COOLER
Model No. CY-CDIC

- Stainless steel construction
- Stainless steel hinged lid with high quality lid seal
- Fully insulated
- Holds cans and/or bottles
- Drain hole included
- Beveled trim



PULL OUT ICE CHEST
Model No. CY-CPOC

- Stainless steel construction
- Fully insulated
- Beveled trim

COMPLEMENTARY PRODUCTS

MODEL	DESCRIPTION	UMRP	BUILDER	MSRP (Retail)
CY-CBIR-R	Outdoor Built-In Refrigerator, 21" - Right Hinge	\$1,099	\$ 1,132	\$ 1,199
CY-CBIR-L	Outdoor Built-In Refrigerator, 21" - Left Hinge	\$1,099	\$ 1,132	\$ 1,199
CY-C1BIR24-L	Outdoor Built-In Refrigerator, 24" - Left Hinge	\$1,499	\$1,544	\$1,649
CY-C1BIR24-R	Outdoor Built-In Refrigerator, 24" - Right Hinge	\$1,499	\$1,544	\$1,649
CY-CDIC	Drop In Cooler	\$ 399	\$ 411	\$ 439
CY-CPOC	Pull Out Ice Chest	\$ 699	\$ 720	\$ 769

COMPLEMENTARY PRODUCTS



REFRESHMENT CENTER
Model No. CY-CRC

- Premium stainless steel construction
- 30" overall width
- Includes drop-in cooler with drain
- Removable Condiment tray insert for drop-in cooler
- Convenient bottle shelf, towel holder and bottle opener
- Cutting board accessory for sink



GRIDDLE
Model No. CY-CXGRDL

- Stainless steel construction
- Fits all 2016 model year grill models
- Removable grease trap
- Use in place of grates

COMPLEMENTARY PRODUCTS

MODEL	DESCRIPTION	UMRP	BUILDER	MSRP (Retail)
CY-CRC	Refreshment Center with Sink, Faucet, and Drop-In Cooler	\$1,199	\$1,235	\$1,319
CY-CGRDL	Heavy-Duty Drop-In Griddle, 2015 and Earlier Models	\$ 249	\$ 256	\$ 279
CY-C1GRDL	Heavy-Duty Drop-In Griddle, 2016 Models	\$ 249	\$ 256	\$ 279

DIMENSIONS AND SPECIFICATIONS

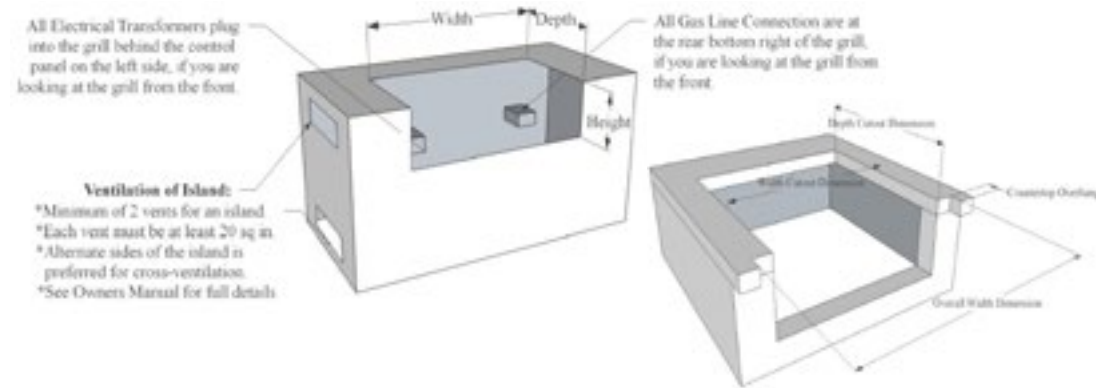

Clearance to Combustible Construction:
When choosing a location for your gas grill, you should not locate it under any combustible construction. The side, bottom, and back of the grill should not be any closer than 24" to combustible material.

Model	Product Description	Cutout Dimensions			Overall Dimensions			Total BTU Ratings		Electrical Outlets Needed (110V)	
		Height	Width	Depth	Height	Width	Depth	LP	NG	Rotisserie	Lights
Grills											
CX2	28" Grill w/ Hood Lights	10 1/4"	25"	20 1/2"	23"	28"	25 1/2"	40,000	40,000	No	Qty 1
C1C28	28" Grill w/ Hood Lights	10 1/4"	26 3/8"	20 1/2"	23"	28"	25 1/2"	40,000	40,000	No	Qty 1
CC(X)3 / C1C34	34" Grill w/ Hood Lights	10 1/4"	31"	20 1/2"	23"	34"	25 1/2"	60,000	60,000	No	Qty 1
CCX4 / C1C36	36" Grill w/ Hood Lights	10 1/4"	32 1/2"	20 1/2"	23"	35 1/2"	25 1/2"	80,000	80,000	No	Qty 1
CS(X)36 / C1S36	36" Grill w/ Hood Lights & Rotis	10 1/4"	32 1/2"	20 1/2"	23"	35 1/2"	25 1/2"	90,000	90,000	Qty 1	Qty 1
CSL(X)36 / C1SL36	36" Grill w/ Hood & LED Lights	10 1/4"	32 1/2"	20 1/2"	23"	35 1/2"	25 1/2"	90,000	90,000	Qty 1	Qty 1
CSL(X)42 / C1SL42	42" Grill w/ Hood & LED Lights	10 1/4"	39 1/2"	20 1/2"	23"	42"	25 1/2"	110,000	110,000	Qty 1	Qty 1
CH(X)50 / C1HY50	50" Hybrid Grill w/ Hood Lights	12 1/2"	47 3/4"	20 1/2"	23"	50"	25 1/2"	40,000	40,000	No	Qty 1
C1CH36	36" Charcoal Grill	12 1/2"	32 1/2"	20 1/2"	23"	35 1/2"	25 1/2"	N/A	N/A	No	No
Side Burners											
CSSB(X) / C1SB	Coyote Single Side Burner	10 1/4"	10 1/8"	13 5/8"	13"	11 3/8"	17"	15,000	15,000	No	No
CDSB(X) / C1DB	Coyote Dual Side Burner	10 1/4"	11 7/8"	20 1/4"	13"	13 1/8"	23 1/4"	30,000	30,000	No	No
CPB / C1PB	Coyote Power Burner	10 1/4"	20 1/2"	21"	13"	24"	24 1/4"	60,000	60,000	No	No
Insulated Jackets											
CIJAKCC2	Insulated Jacket for 28" Grills	11"	28 1/4"	21 3/4"	11"	30 3/4"	22 1/4"	For Combustible Construction			
CIJAKCC3	Insulated Jacket for 34" Grills	11"	34 1/4"	21 3/4"	11"	36 3/4"	22 1/4"	For Combustible Construction			
CIJAKCS36	Insulated Jacket for 36" Grills	11"	35 3/4"	21 3/4"	11"	38 1/4"	22 1/4"	For Combustible Construction			
CIJAKCS42	Insulated Jacket for 42" Grills	11"	42 1/2"	21 3/4"	11"	45"	22 1/4"	For Combustible Construction			
Access Doors											
CDA2426	26" Double Access Door	20 1/2"	20 3/4"	N/A	24"	24 1/4"	3"	N/A			
CDA2431	31" Double Access Door	20 1/2"	26 1/2"	N/A	24"	30"	3"	N/A			
CDA2439	39" Double Access Door	20 1/2"	34 1/2"	N/A	24"	38"	3"	N/A			
CSA2014	Single Access Door 20" x 14"	20 1/2"	14 1/2"	N/A	22"	16"	3"	N/A			
CSA1420	Single Access Door 14" x 20"	14 1/2"	20 1/2"	N/A	16"	22"	3"	N/A			
CSA2417	Single Access Door 24" x 17"	24 1/2"	17 1/2"	N/A	26"	19"	3"	N/A			
CSA1724	Single Access Door 17" x 24"	17 1/2"	24 1/2"	N/A	19"	26"	3"	N/A			
Drawers											
C2DC	2 Drawer Cabinet	20 1/2"	14 1/2"	17 1/2"	22"	16 1/4"	18"	N/A			
C3DC	3 Drawer Cabinet	24 1/2"	16 3/4"	17 1/4"	26"	18 1/2"	18"	N/A			
CSSD	Single Storage Drawer	13 1/2"	31 1/2"	20 1/2"	15"	32 1/2"	21 1/4"	N/A			
CDPC31	31" Dry Pantry	20 1/2"	26 1/2"	23"	24"	30"	24"	N/A			
CTC	Pull Out Trash & Recycle	23 7/8"	23 3/4"	18"	26 1/4"	26 3/4"	19"	N/A			
CPOD	LP Tank or Trash Drawer	20 1/2"	14 1/4"	17 1/2"	22"	15 1/2"	18"	N/A			
CPTH	Paper Towel Holder	8 1/4"	13 1/2"	8"	10"	15"	9"	N/A			
CWD	Warming Drawer	9 1/2"	28 1/4"	23 1/2"	10 3/4"	29 1/2"	26 3/4"	Qty 1 Plug Needed - unit is 450 Watt			
Combo Drawers											
CCD-2DC	Double Drawer Combo	20 1/4"	43 3/8"	17 1/8"	24 1/8"	45 1/4"	18 3/8"	N/A			
CCD-2DC31	31" Double Drawer Combo	20 1/2"	26 1/2"	20 1/8"	24"	30"	21 1/8"	N/A			
CCD-POD	Pull Out Drawer Combo	20 3/8"	43 3/8"	16 1/4"	24 1/8"	45 1/4"	17 1/2"	N/A			
CCD-WD	Warming Drawer Combo	19 1/2"	40 5/8"	25 1/4"	20 3/4"	42 1/8"	26 1/2"	Qty 1 Plug Needed - unit is 450 Watt			
Refrigeration & Refreshment Centers											
CBIR	4.1 Outdoor Refrigerator	34"	20 3/4"	23"	33 3/4"	20 1/2"	22 3/4"	Qty 1 Plug Needed - Vented Bottom Front			
C1BIR24	5.5 Outdoor Refrigerator	33 1/4"	23 3/4"	22 3/4"	33"	23 1/2"	22 1/2"	Qty 1 Plug Needed - Vented Bottom Front			
CDIC	Drop In Cooler	12"	23 1/4"	17 1/4"	15"	24 1/2"	18"	Can be turned in either direction			
CPOC	Pull Out Ice Chest	17 1/2"	23 3/4"	24 3/4"	20 1/2"	26 3/4"	25 1/2"	Additional support for weight needed			
CRC	Refreshment Center	10"	29 1/4"	22 3/4"	10 3/4"	30 1/4"	29"	Drain Hose Included			

Cutout Dimensions: Build your bbq island to these specifications to ensure proper fit of the product being used.
Overall Dimensions: Describe the actual dimensions of the product once it is resting/installed in a bbq island.
Clearance to Combustibles: The dimensions required by the manufacturer for clearance to combustible materials.
Total BTU Ratings: These numbers show the total volume of gas used by the product while operating at full capacity.

WARRANTY AND SERVICE INFORMATION

PINNACLE EXPRESS LIMITED WARRANTY

Pinnacle Express, Inc. offers a Limited Parts and Labor Warranty at no charge on all Outdoor Gas Grills and Side Burners to the original purchaser at the original site of delivery with proof of purchase from a Pinnacle Express, Inc. authorized dealer based on normal residential use. This Warranty specifically EXCLUDES ANY PRODUCT USED IN RENTAL OR COMMERCIAL APPLICATIONS AND ANY GRILL PURCHASED THROUGH AN INTERNET DEALER. This Warranty may be extended for one (1) additional year with the purchase of 2YRWARR, described in the Price Book as a Two Year Limited Parts and Labor Warranty. If purchased, 2YRWARR will provide a homeowner with a full 24 months of coverage from the date of purchase.

Pinnacle Express, Inc.'s obligation under this Warranty is limited to repair or replacement of product, at Pinnacle Express's option in collaboration with Coyote Outdoor Living, during the warranty period. This Warranty does not cover normal wear of parts or damage resulting from any of the following: negligent use or misuse of the product, use of improper fuel/gas supply, use contrary to operating instructions, or alteration by any person other than a factory authorized service center. The warranty period is only from the date of original purchase and is not extended by any repair or replacement.

Pinnacle Express One Year Limited Parts and Labor Warranty No Charge
 Pinnacle Express Two Year Limited Parts and Labor Warranty Additional Fee

Please contact your Pinnacle Express Representative for any questions you may have.

LIMITED WARRANTY

Coyote Outdoor warrants to the original purchaser at the original site of delivery with proof of purchase of each outdoor gas grill/side burner that when subject to normal residential use, it is free from defects in workmanship and materials for the periods specified below. This warranty excludes grills used in rental and commercial applications. This warranty excludes surface corrosion, scratches, and discoloration which may occur during regular use. The Coyote Outdoor Warranty does NOT cover labor or labor related charges.

COMPONENT WARRANTY PERIOD

Cooking Grids (no rust or burn through) 5 years (limited)
 Flavorizer Bars (no rust or burn through) 2 years (limited)
 Electric/Plastic Components 2 years (limited)
 Ignition Systems/Valves 1 year (limited)
 Stainless Steel Frame/Housing Limited Lifetime
 Stainless Steel Burners (no rust or burn through) Limited Lifetime

Our obligation under this warranty is limited to repair or replacement, at Coyote's option, of the product during the warranty period. The extent of any liability of Coyote under this warranty is limited to repair or replacement. This warranty does not cover normal wear of parts or damage resulting from any of the following: negligent use or misuse of the product, use of improper fuel/gas supply, use contrary to operating instructions, or alteration by any person other than a factory service center. The warranty period is not extended by such repair or replacement.

WARRANTY CLAIM PROCEDURE:

If you require service or parts for your Coyote Grill, please contact the Warranty Service Center for factory direct assistance. Hours of operation are 8 am to 4 pm CST. The phone number is 855.520.1559 and the fax number is 214.520.1450. You may also fill out warranty claims online at www.coyoteoutdoor.com. Please have your model number, serial number and proof of purchase available for any warranty claim.

Coyote Outdoor may require the return of defective parts for examination before issuing replacement parts. If you are required to return defective parts, shipping charges must be prepaid by the customer. Upon examination and to Coyote Outdoor's determination, if the original part is proven defective, Coyote Outdoor may approve your claim and elect to replace such parts without charge. In any instance, customer is responsible for shipping and handling of the replacement parts. Product repair as provided under this warranty is your exclusive remedy. Coyote Outdoor shall not be liable for any incidental or consequential damages for breach of any expressed or implied warranty on its products.

This warranty does not cover any failures or operating difficulties due to accidents, abuse, misuse, alteration, misapplication, vandalism, improper installation, maintenance or service, damages caused by flashback fire or grease fires, as set out in the Owner's Manual. This warranty does not cover scratches, dents, corrosion or discoloration caused by weather, heat, abrasive and chemical cleaners, pool or spa chemicals, and/or any tools used in the assembly or installation of this unit. This warranty does not cover paint loss, surface rust, corrosion or stainless steel discoloration which is considered normal wear and tear. This warranty does not cover the cost of any inconvenience, personal injury, or property damage due to improper use or product failure. Deterioration or damage due to severe weather conditions such as hail, hurricanes, earthquakes, tsunamis, tornadoes, terrorism, discoloration due to exposure to chemicals either directly or in the atmosphere, Acts of God/Forces of Nature are not covered by this limited warranty.



Pinnacle Express, Inc.
P.O. Box 1836 • Dundee, FL 33838
P: 800-292-8374 • F: 800-574-8805
www.pinnacleexpress.com