

THE INSIDE ADVANTAGE™



*CHOOSE QUALITY.....*

# WHIRLPOOL® BRAND COMMERCIAL LAUNDRY PRODUCTS

*FEATURING*  
FACTORY EQUIPPED  
COIN SLIDE AND COIN BOX



Reliability, Flexibility, Durability, and Simplicity . . . From the Industry Leader in Laundry

Whirlpool Brand.  
In a word,  
**Cha-Ching!**

Water and energy savings. Front-service access.

A nationwide support network. And dependability and simplicity you and users recognize.

It's all yours from the industry leader in laundry - Whirlpool Corporation.

Whirlpool® commercial laundry.

Like money in the bank.

800-NO-BELTS (800-662-3587).



THE INSIDE ADVANTAGE™



POWERFUL BRANDS • INNOVATIVE PRODUCTS  
CONSUMER INSIGHT • TARGETED SERVICES

## SECURITY FEATURES OFFERED ON ALL WHIRLPOOL® COMMERCIAL LAUNDRY PRODUCTS

- Washer tops and lids are coated with porcelain to resist chipping and rusting and will withstand the harsh chemicals used in a laundry environment.
- Washer and dryer cabinets are designed to be some of the most durable in the industry. Heavy galvanized metal gives Whirlpool Corporation the advantage to guarantee cabinets against rust-through (see warranty for details.)
- Torx® console screws are made of rustproof stainless steel and may not be removed with the average screwdriver.
- The optional front lock offers you extra security by tying the front and top of the machine together. The appearance of the lock may be enough to deter the common vandal.
- The hidden lid switch on our washers ensures safe operation and tamper prevention.

Whirlpool® Fabric Care technology provides a tried and true solution for consumers that prefer a top load washer. Whirlpool Corporation has designed a top load washer that is easy to use and delivers exceptional and dependable cleaning performance. Choose Whirlpool® Commercial Laundry for your coin store, multi-housing, and university projects.

Reliability, Flexibility, Durability, and Simplicity.

Whirlpool Corporation has a Dedicated Sales and Service Staff Committed to the Success of your Commercial Laundry Business. Please Contact us at 1-800-NO-BELTS (1-800-662-3587).



**Rick Trama**  
Technical Communications  
Manager



**Debra Hart**  
Order Processing



**Byron Hatch**  
National Sales  
Manager

## WHIRLPOOL® HOME APPLIANCES. WORLD'S BEST SELLING HOME LAUNDRY\*

It's the 21st century and "good enough" just isn't enough anymore. Your customers expect more from their laundry facility. They want easy to use, large capacity machines that provide many options for quality fabric care.

The entire commercial line-up of Whirlpool® washers and dryers follows with exceptional capacity, cleaning, and drying performance. Each model has combined fabric care options and conveniences that enhance **your power to satisfy each customer's needs.**

### Seven Key Factors to Consider During Your Equipment Selection:

1. Energy Consumption
2. Ease of Use
3. Performance
4. Durability
5. Flexibility
6. Security
7. Warranty

### Coin Store

Customers feel secure knowing that they are using equipment backed by the world's largest manufacturer of laundry products. Our experienced Whirlpool distributors will guide you through every step of creating a new coinstore or retrofitting your existing location.

### Multi-Housing

Whether you choose the convenience of a route operation agreement, or to own and maintain your own equipment, you can trust that Whirlpool® Commercial Laundry has the products to suit the needs of you and your tenants.

Whirlpool Corporation offers some of the most recognized and trusted brands in the world. Brands that your residents trust for quality, reliability and efficiency. As a Property Manager, you need to make the right selection of products for your laundry areas. Choose Whirlpool® brand Commercial Laundry from the WORLD'S LEADING BRAND of major home appliances!\*

### University

In the realm of university life, security, reliability and durability are of utmost importance. Let us "educate" you on the advantages of using Whirlpool® Commercial Laundry products featuring factory equipped coin slide and coin box.

## MAXIMIZE REVENUE

Whirlpool® Commercial Laundry Products featuring factory equipped coin slide and coin box are designed for **simplicity, durability, and flexibility** to meet a variety of needs. A simple mechanical timer and Direct-Drive,

**NO BELT Washing System** offers years of reliable operation at a very competitive price. Every Whirlpool® Washer features the 2 speed advantage, offering a true low speed gentle wash option. A high speed spin of 640 rpm ensures optimal water extraction.

A 10% owner adjustable water savings switch can reduce overall water consumption to 31 gallons per cycle!

A heavy gauge, galvanized cabinet with porcelain top and lid is difficult to dent and resists rust.

### WHIRLPOOL® DIRECT-DRIVE, NO-BELT WASHING SYSTEM



During the service lifetime of a typical Maytag® Speed Queen® or GE® commercial belt-driven top load washer, it is possible that many belts will need to be replaced. Belt driven washing machines rely on belt slippage to slowly build up spin speed.

Machines get overloaded - Belts wear - Belts break - and your machine is out of commission.

#### WHY SETTLE FOR 50 YEAR OLD BELT-DRIVEN TECHNOLOGY?

Whirlpool® Direct-Drive, NO BELT, enclosed clutch washers eliminate the need for belts. Whirlpool® brand Direct-Drive washer motor coupler isolators feature a heavy duty automotive design. They have been tested to 20,000 cycles without failure!\*

No belts equate to less hassle, fewer repairs, and an uninterrupted income stream for you.

VS



WHIRLPOOL

THE COMPETITION

**One Durable  
Whirlpool® Motor  
Coupler Isolator Can  
Be Equivalent to  
Many Competitive  
Product Belts!**

Maximize the Efficiency and Profitability of Your Laundry Area with  
Whirlpool® Brand Commercial Laundry Products Featuring Factory Equipped Coin Slide and Coin Box

\*Whirlpool Lab Testing, 2001

For warranty details, see information packed with your product.  
Call 1-800-NO-BELTS or visit [www.coinop.com/warranty.asp](http://www.coinop.com/warranty.asp)

## WHIRLPOOL® BRAND COMMERCIAL WASHERS

## COMMERCIAL WASHER

featuring factory installed  
coin slide and coin box



### DIRECT DRIVE SYSTEM

27" Heavy-duty Commercial Washers feature the Direct-Drive, No-Belt Washing System for greater reliability, reduced down time and increased profits.

### LARGE CAPACITY WASH BASKET

Ideal for handling family size loads!

### PORCELAIN FINISH

Porcelain top and lid finish resists rust, chipping and scratching.



### FRONT LOCK READY

Factory installed lock blank provides a visual vandalism deterrent.

To further discourage theft, order optional front panel lock assembly (part #358290) for the added security of tying the front and top panels together.



### 10% WATER SAVINGS OPTION

Rear panel-mounted, owner adjustable

water savings option increases energy efficiency by reducing water consumption to 31 gallons per cycle when selected.



### TRIPOD SUSPENSION

Sturdy tripod suspension with active liquid filled balance ring reduces

product weight while balancing commercial size laundry loads.



### RUST PROOF SCREWS

Rust proof Stainless Steel Torx® control panel screws give your machines

added security and service life!



### SEALED HIDDEN LID SWITCH

To help ensure safe operation, Whirlpool® commercial washers

feature a lid switch that is truly hidden. Not only does this prevent tampering, it ensures that the washer will not operate when the lid is open.



## CAM2752K - 27" 2-Speed Washer with Factory Installed Coin Slide and Coin Box

**EXCLUSIVE  
1 YEAR FACTORY LABOR  
WARRANTY!!**

- 2.5 Cu. Ft. Wash Basket
- Push Button Controls
- 3 Cycles: Cotton (Hot), Wrinkle Free (Warm), and Colorfast (Cold)
- Two-Speed Advantage With True Gentle Wash, High Speed Spin Only!
- Porcelain Top and Lid, Rust Proof Stainless Steel Hinges and Console Screws
- Hidden Lid Switch
- Galvanized, Heavy Gauge Cabinet Back, Side and Front Panels, Removable Front Service Panel
- Heavy Duty Motor Coupler Isolator Tested to 20,000 Cycles!
- Reliable, Direct-Drive NO BELTS drive system, front and bottom serviceable
- High Speed Spin 640 rpm (approx.)
- Extra Long Power Cord and Commercial-Grade, Color-Coded Water Inlet Hoses with Brass Couplings and EDPM Rubber Drain Hose Included
- 3 Cycle Indicator Lamps.
- **1/3/7/10 Year Parts Warranty\*\***
- 8 Quarter Coin Slide Capacity, Set Your Wash Price From \$0-\$2 Per Cycle.

\*\*Call 1-800-NO-BELTS for warranty details.

## COMMERCIAL DRYERS

featuring factory installed  
coin slide and coin box



**CEM2750K - 27" Electric Dryer**  
**CGM2751K - 27" Gas Dryer**  
with Factory Installed Coin Slide  
and Coin Box

**EXCLUSIVE**  
**1 YEAR FACTORY LABOR**  
**WARRANTY!!**

- Large 7.4 Cubic Ft. Drum Capacity
- Push Button Controls
- 3 Cycles: Regular/Heavy (High Heat), Permanent Press (Medium Heat), and Knits/Delicates (Low Heat)
- Large, Removable, Door-Mounted Lint Screen (84 sq. in.)
- 180 Degree Wide-Opening Side-Swing Door
- Porcelain Top, Powder Coat Cabinet
- Front-Service Accessibility
- Four-Way, Multi-Vent Options (back, bottom, and sides)
- Electric Model Features Element Rated at 5600 Watts 240Volts
- Gas Model Features a 22K BTU Burner
- Motor: 1/3-HP With Built-In Overload Protector; Centrifugal Switch Turns Off Heating Element When Motor Stops
- Easy-to-Follow Console Instructions
- Power Cord Sold Separately (Electric Model Only)
- **1/3/7 Year Parts Warranty\*\***
- 8 Quarter Coin Slide Capacity, Set Your Dry Price From \$0-\$2 Per Cycle.

\*\*Call 1-800-NO-BELTS for warranty details.

## WHIRLPOOL® BRAND COMMERCIAL DRYERS



**FRONT LOCK READY**  
Factory installed lock blank provides a visual vandalism deterrent.

To further discourage theft, order optional front panel lock assembly (part #358290) for the added security of tying the front and top panels together.

### 1/3HP MOTOR

1/3HP motor with overload protection.

### THERMOSTAT

Single operating thermostat for simple accurate temperature control.



### BALANCED AIRFLOW SYSTEM

Whirlpool® commercial dryers have an energy-efficient balanced airflow system that circulates air throughout the drum to equalize drying temperatures (with a normal venting system.)

### LARGE CAPACITY METERCASE

Larger coinbox for reduced collections.

### LARGE 7.4 CU. FT. DRUM CAPACITY



The increased capacity allows for large loads of clothes tumble and spread, saving you and your customers drying time and expense.



### LARGE LINT FILTER

Pull-out, 84 square inch lint filter.

### 4 WAY-VENTING

4 Way-venting from left or right side, back or bottom.



### SIDE SWING DOOR

For convenient access, the wide-opening side-swing door can be opened a full 180°.



### RUST PROOF SCREWS

Rust Proof Stainless Steel Torx® control panel screws give your machines added security and service life.

## COMMERCIAL WASHER SPECIFICATIONS

WASHER SPECIFICATIONS	
<b>MODEL NUMBER</b>	<b>CAM2752K</b>
<b>GENERAL INFORMATION</b>	Metercase Model Factory installed Coin Slide and Coin Box, \$0-2 per cycle, \$1.00 Factory Preset
	Stainless Steel Look Push Button console, with hidden lid switch, porcelain finish top and lid, galvanized, extra thick front panel, back and side panels, improved meter case, reliable single piece agitator, front panel lock blank factory installed. Commercial-Grade, Color-Coded Water Inlet hoses with Brass couplings and Rubber Drain Hose Included
<b>MOTOR</b>	Two-Speed Advantage With True Gentle Wash high speed spin only!
	120V 1/2 HP Direct-Drive with Built-In Overload Protector
<b>AGITATION STROKES PER MINUTE/AMPERAGE</b>	180spm/high (5.0 amps no load) 120 spm/load (5.0 amps no load) 9.8 amps (120V)
	Maximum Rated Amperage
<b>MOTOR RPM</b>	1725 High 1140 Low
<b>SPIN RPM</b>	640 High
<b>ELECTRICAL REQUIREMENTS</b>	120V, 60 Hz., A.C. standard 15-amp breaker/fuse branch circuit for each washer (subject to local codes)
<b>DIMENSIONS</b>	43"H (at metercase top) 35"H (at lid). 27"W, 25.5"D
	See Illustration Below
<b>SHIPPING WEIGHT (EST.)</b>	184 lbs
<b>BASKET VOLUME</b>	2.5 Cubic Feet

Dimensions are for planning purposes only. For complete information, see installation instructions packed with product.

**NEW YORK CITY  
M.E.A.**

Energy information is available online at [www.coinop.com/products](http://www.coinop.com/products), WP literature part #CWXL077

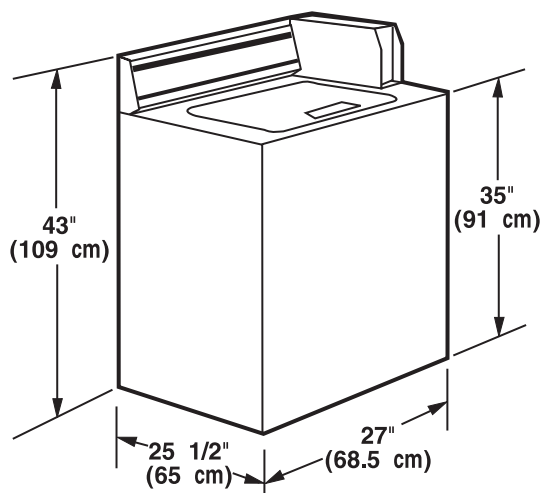

WASHER FRONT VIEW

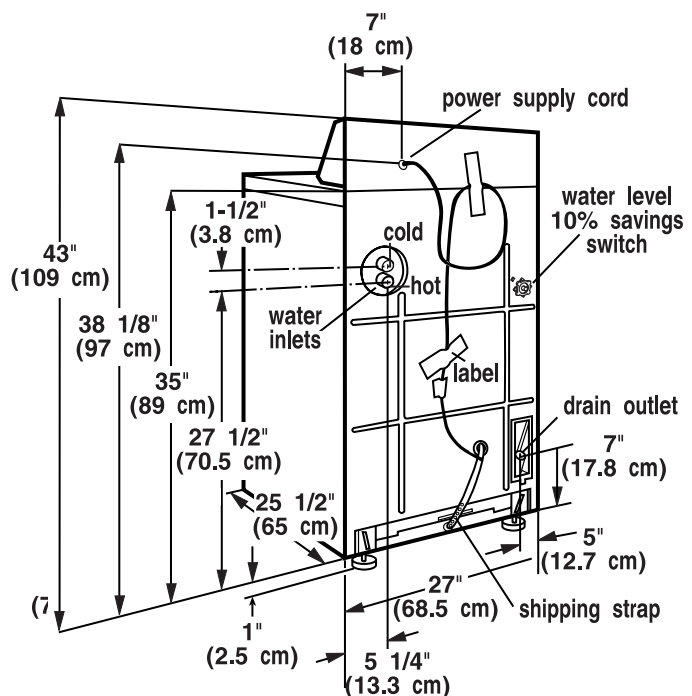

WASHER BACK VIEW

## COMMERCIAL DRYER SPECIFICATIONS

### SINGLE DRYER SPECIFICATIONS

MODEL NUMBER	CEM2750K*	CGM2751K*
<b>GENERAL INFORMATION</b> Stainless Steel Look Push Button console, white enamel drum, porcelain finish top, powder coat cabinet, front panel lock blank factory installed, removable indoor lint filter, improved meter case. 4 Way Venting.	Metercase Model Factory installed Coin Slide and Coin Box, \$0-2 per cycle, \$1.00 Factory Preset	Metercase Model Factory installed Coin Slide and Coin Box, \$0-2 per cycle, \$1.00 Factory Preset
<b>ELECTRICAL REQUIREMENTS</b>	3-wire nominal 240/208V, 60 Hz, A.C. standard 30-amp breaker/fuse branch circuit per dryer (subject to local codes)	Nominal, 120V, 60Hz, A.C., standard 15-amp breaker/fuse branch circuit per dryer (subject to local codes)
<b>MOTOR</b>	1/3 HP Single Speed Motor with Built-In Overload Protector 5.9 Amps max rating	1/3 HP Single Speed Motor with Built-In Overload Protector 5.9 Amps max rating
<b>HEATER TYPE</b>	<b>ELECTRIC</b>	<b>GAS**</b>
<b>HEATER/ BURNER RATING</b> (Add 500 watts approx for motor on all dryer models)	Heater Rated at 5600 watts	22,000 BTU/h Natural Gas
<b>AMPERAGE</b> (Does not include control or gas valve)	Motor - 4.0 amps No load Heater - 23.33 amps @ 240V 27.33 Total	Motor - 4.0 amps No load
<b>DIMENSIONS</b> See Illustration Below	43"H*, 27"W, 28.5"D	43"H*, 27"W, 28.5"D
<b>SHIPPING WEIGHT (EST.)</b>	134 lbs	135 lbs
<b>DRUM VOLUME</b>	7.4 Cubic Feet	7.4 Cubic Feet

### Exhaust Information

All dryers require the equivalent of a 4-inch diameter exhaust duct. Rigid metal duct is recommended. Failure to properly exhaust the dryer will result in improper operation.

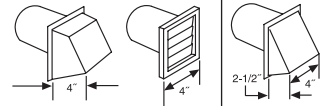

27" & 29" Dryer Venting Requirements

# of 90° turns	4" Hood	2 1/2" Hood
<b>Maximum length of 4" diameter rigid metal duct</b>		
0	64 Ft.	58 Ft.
1	54 Ft.	48 Ft.
2	44 Ft.	38 Ft.
3	35 Ft.	29 Ft.
4	27 Ft.	21 Ft.
<b>Maximum length of 4" diameter flexible metal duct</b>		
0	36 Ft.	28 Ft.
1	31 Ft.	23 Ft.
2	27 Ft.	19 Ft.
3	25 Ft.	17 Ft.
4	23 Ft.	15 Ft.

Dimensions are for planning purposes only. For complete information, see installation instructions packed with product.

\* (height at meter case top) \*\*\* (height at dryer top panel)

\*\* Burner orifices are available for manufactured, natural, mixed, and LP gas with varying BTU ratings.

• LP Conversion Kit: 49572

▲ Power cords on electric models sold separately

Energy information is available online at [www.coinop.com/products](http://www.coinop.com/products). WP lit# CWXL077

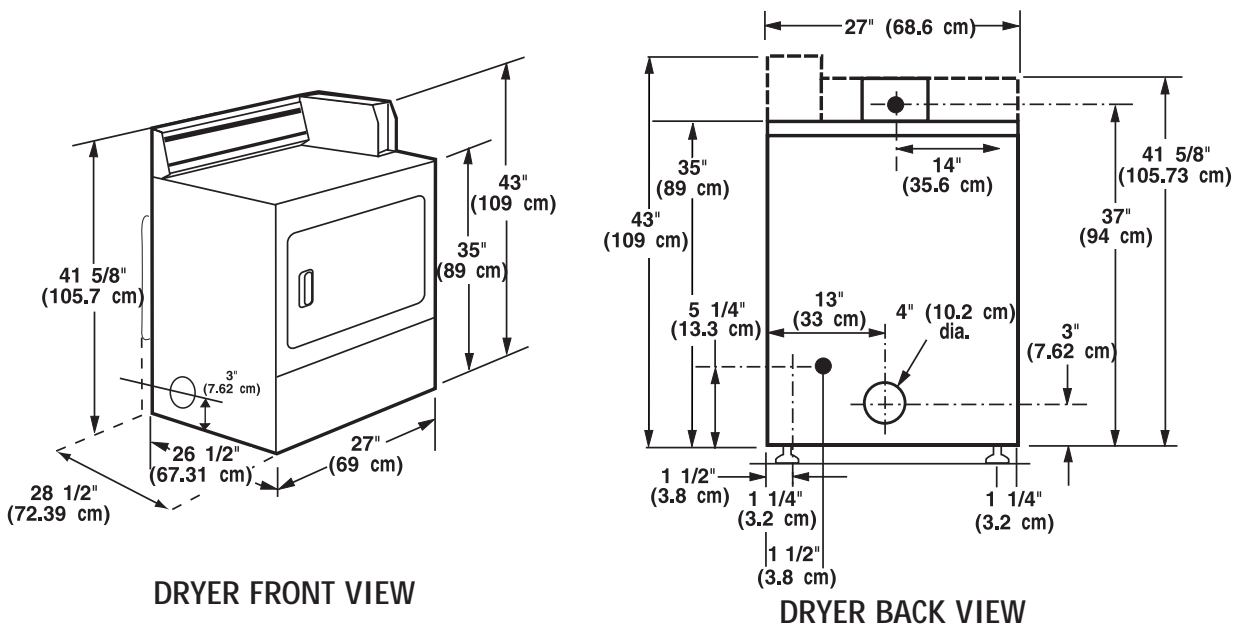

## MONEY ACCEPTOR PARTS CROSS REFERENCE



KEY PART NAME	WHIRLPOOL PART No.	ESD PART No.
1 DOOR SERVICE	3351138	N/A
2 VERTICAL 8 COIN KIT* (WASHER AND DRYER) (Includes 5, 6, 9, 10, 12, 14, 24)	3954807	72093
3 KEY FRONT LOCK OR TOP LOCK	358288	MULTIPLE OPTIONS
4 MONEY BOX WITH KEY	8316525	72101-XD
5 VERTICAL 8 COIN SLIDE* (Slide Only)	8316520	V8-200 (71689)
6 COIN SLIDE EXTENSION WASHER	8316522	21053
7 COINSLIDE EXTENSION DRYER	8316523	21064

KEY PART NAME	WHIRLPOOL PART No.	ESD PART No.
8 BOLT SLIDE MECHANISM	8316521	21749
9 DECAL KIT	8316524	72097
10 INSERT, BLANK	8316264	21216
11 INSERT \$.25	8316265	21193
12 FRONT LOCK ASSEMBLY	358290	0300-ETWH
13 DRYER TIMER CAMS		
3-PIN (60 MINUTES)	3387974	N/A
4-PIN (45 MINUTES)	339855	N/A
6-PIN (30 MINUTES)	343777	N/A
9-PIN (20 MINUTES)**	338854	N/A
12-PIN (15 MINUTES)**	359853	N/A
14 Front Lock Blank	38731	N/A

\*STATE COINAGE TYPE (US QUARTER, US DOLLAR, CANADIAN DOLLAR, CANADIAN QUARTER, CANADIAN DOLLAR, ETC.)

\*\*OPTIONAL TIMER CAMS AVAILABLE THROUGH WHIRLPOOL PARTS.

MODIFICATIONS MAY VOID THE WHIRLPOOL CORPORATION PRODUCT WARRANTY.

## MONEY ACCEPTOR MANUFACTURER CONTACT INFORMATION

MANUFACTURER	ESD	WHIRLPOOL
ADDRESS	270 New Jersey Drive Fort Washington, PA 19034	150 Hilltop Rd. St. Joseph, MI 49085
PHONE	1(800) 523-1510	1(800) 662-3587, option 1
EMAIL	info@esdcoin.com	Byron_W_Hatch@ whirlpool.com

## WARRANTIES

### EXCLUSIVE 1 YEAR FACTORY LABOR WARRANTY!!

WASHER WARRANTIES	
3-Year Limited (parts only)	Entire Product
7-Year Limited (parts only)	Cabinet (Against Rust-Through)(Center Post Bearings and Seals)
10-Year Limited (parts only)	Wash Basket and Outer Tub
DRYER WARRANTIES	
3-Year Limited (parts only)	Entire Product
7-Year Limited (parts only)	Cabinet (Against Rust-Through)

For important information regarding warranty inclusions, exclusions and limitations, please call 1-800-NO-BELTS



THE INSIDE ADVANTAGE™



From Whirlpool Corporation - A World Leader in Laundry Products

<http://coinop.com>

TORX is a registered Trademark of Textron Industries, Inc.

®Registered trademark/™Trademark of Whirlpool, U.S.A.

©2004 Whirlpool Corporation. All rights reserved.

Whirlpool Corporation • Benton Harbor, Michigan 49022 U.S.A.