

**FFAR22LMED**

20.18" x 17.38" x 19.0" (H x W x D)

Compact auto defrost all-refrigerator with a lock, temperature alarm, and hospital grade cord

**Highlights:**

- Compact size is ideal for countertop use
- Simple maintenance with auto defrost interior
- Factory installed lock provides security you can count on
- High temperature alarm includes external temperature readout



|   |  |
|---|--|
| Compact dimensions                        | Ideal size for use on top of counters  |
| Automatic defrost                         | Reduced maintenance with auto defrost system   |
| Internal fan with gel packs               | Fan-forced cooling ensures the unit is evenly cooled from top to bottom                    |
| High temperature alarm                    | Warns of temperature fluctuations and includes an external temperature readout on the door |
| Hospital grade cord with 'green dot' plug | Secure three-pronged cord for added unit safety  |
| Removable shelf                           | Wired shelf provided   |
| Door storage                              | Store items right on the door for easy access  |
| Adjustable thermostat                     | Manage the temperature with ease and accuracy  |
| 100% CFC Free                             | Environmentally friendly design with no ozone-damaging chemicals                           |

## Specifications:

|                            |                    |
|----------------------------|--------------------|
| Height                     | 20.18"             |
| Width                      | 17.38"             |
| Depth                      | 19.0"              |
| Capacity                   | 1.6 cu.ft.         |
| Interior Height 1          | 16.5"              |
| Interior Width 1           | 14.18"             |
| Interior Depth 1           | 14.5"              |
| Comp Step Height           | 6.75"              |
| Comp Step Width            | 14.18"             |
| Comp Step Depth            | 5.25"              |
| Shipping Weight            | 55.0 lbs.          |
| Weight                     | 35.0 lbs.          |
| Amps                       | 1.2                |
| Canadian Electrical Safety | CSA                |
| US Electrical Safety       | CSA                |
| Voltage/Frequency          | 115 V AC/60 Hz     |
| Reversible                 | Factory Reversible |
| Door Swing                 | RHD                |
| Shelf Quantity             | 1                  |
| Shelf Type                 | Wire               |
| Full Door Shelf Quantity   | 1                  |
| Half Door Shelf Quantity   | 1                  |
| Defrost Type               | Automatic          |
| Height to Hinge Cap        | 20.5"              |
| Thermostat Type            | Dial               |
| Fan Type                   | Interior           |
| Level Legs Quantity        | 2                  |
| Freon Type                 | R134a              |
| High Side PSI              | 270.0              |
| Freon Oz                   | 1.94               |
| Low Side PSI               | 103.0              |
| Parts/Labor Warranty       | 1 Year             |
| Compressor Warranty        | 5 Years            |

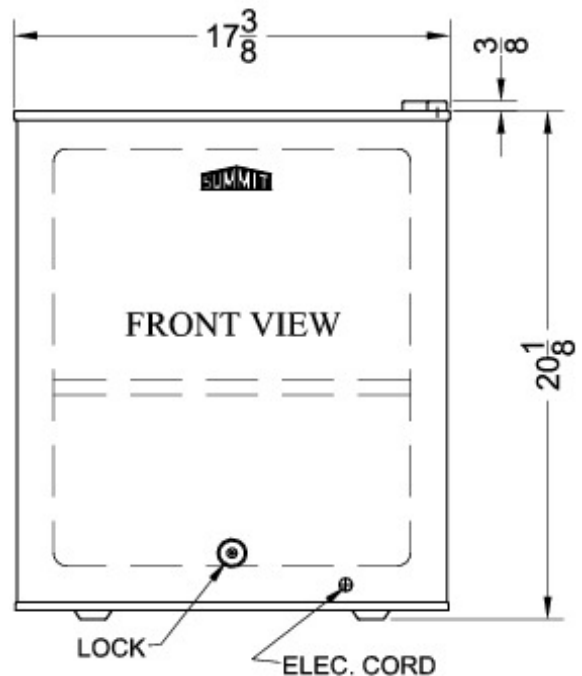
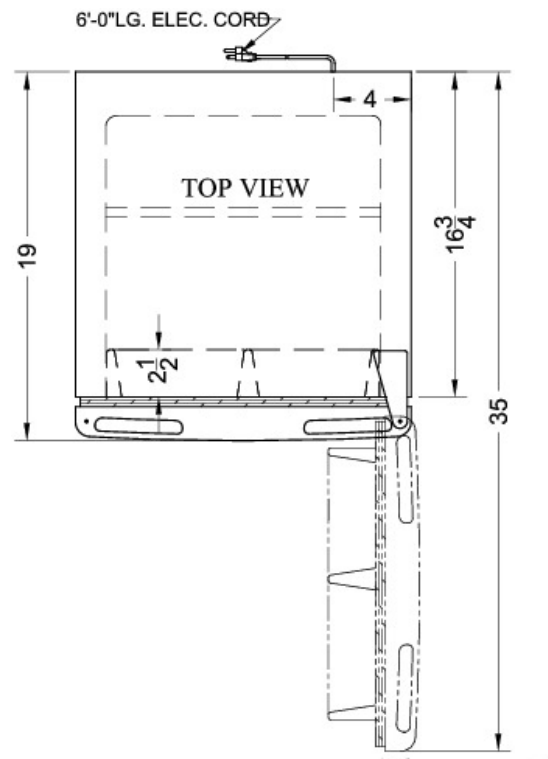

Summit Appliance Division, Felix Storch, Inc.  
 770 Garrison Ave • Bronx, NY 10474  
 Phone: 718-893-3900 • Fax: 718-842-3093  
 Email: info@summitappliance.com